

# NH – Easy Line Fuse switch disconnector

100 - 630 A - 400 / 500 / 690 V

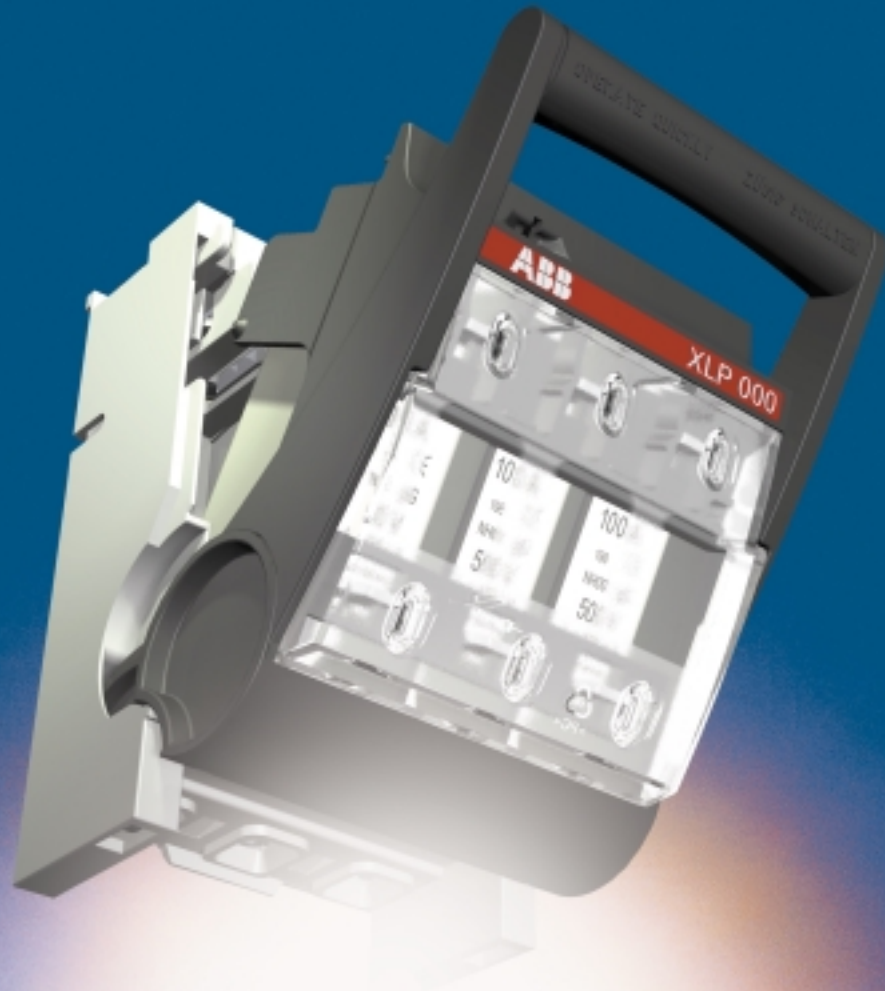



## Contents:

Fuse protection	4
General description	5
3 pole: XLP000	6
XLP00	7
XLP1	8
XLP2 / 3	9
4 pole: SLP 00 – 3	10
Electronic Fuse Monitor	11
System description	12
	13
Cable clamps and bolts	14
	15
Technical data	16
	17
	18
Ordering tables	19
	20
	21
Dimensional drawings	22
	23
	24
	25
	26

# EasyLine

## Fuse protection

### Fuse protection – Easy and reliable

The fuse is a superior short circuit protection element regarding the maximum allowed cut-off current (peak let through current) and energy value. This is more important the higher the voltage and prospective fault levels are. The SlimLine switch fuses fulfil the highest requirements for modern switch fuses with a total safety concept. The switch fuses are tested according to the EN 60947-3 standard with more stringent requirements for isolation, making, performance and safety. The fuse rails are tested according to IEC 60269-2-1.

The melting curves and current limiting diagrams for NH fuse links are given in the IEC 269-2 standard. The standardised fuse characteristics and high degree of current limitation ensure that there is a simple and effective co-ordination with fuse links and other devices.

Fuse links provide a simple procedure for selecting the right fuse type for your installation, without complicated calculations or calculation tools. Fuses prevent “blackouts”. Only the fuse nearest a fault trips without upstreams fuses (feeders or mins) being affected. Fuses thus provide selective coordination.

When more power is needed in an installation, more feeders can be added without changing the present structure or any new selectivity calculations. Fuse links will assure selectivity in the installation by 1,6:1 difference in the rated current.

### Economical installation

Lifetime costs of fuse systems are low. Fuse links which can withstand a high fault level and a fault current, are available at economical prices. After fuse operation, only the fuse link has to be changed. Because the fuse links can be rapidly and easily replaced, plant down time and maintenance are substantially reduced with a fuse link system.

Because the fusing elements operate in a cylinder, they are not affected by their surroundings. Thus their protecting characteristics remain stable year after year. The dynamic stress on the network and its equipment is dependent of the let through energy ( $i^2t$ ) at a short circuit. The fuse link provides the best protection compared to other solutions, at high short circuit currents.

As the fuse link body is filled with quartz sand, there will be no emission of gases or arcs when a short circuit occurs. This again leads to less stress on the network and a higher degree of personal safety.

### Fuse protection – Easy and reliable

- Economical installation
- Easy and economical selectivity
- No need for calculation tools
- No need to change the present structure when more power is needed
- No moving parts
- No extra operation time
- No arc space
- No emission of gasses at short circuits

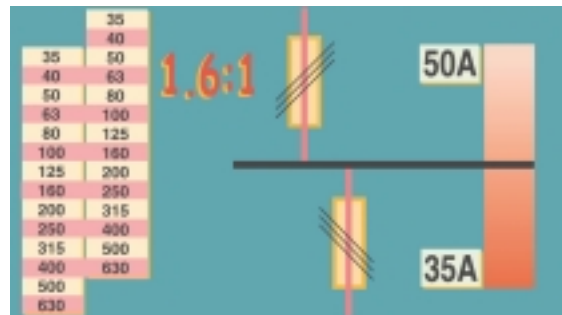

**No need for calculation tools**  
**- Easy and economical selectivity**

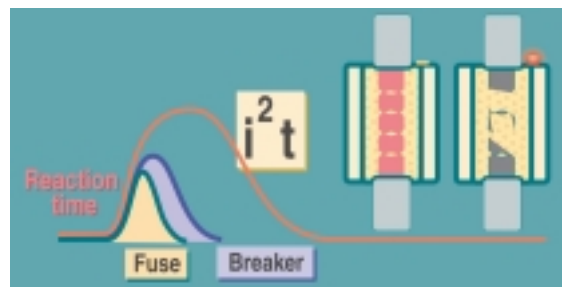

**No moving parts**  
**- No extra operation time**

# EasyLine

## General description

### EasyLine

#### - A new generation designed for you

#### Product presentation

EasyLine is the new complete generation of fuse switch disconnectors including the following members:

##### 3 - pole:

- XLP000 100 Amp
- XLP00 160 Amp
- XLP1 250 Amp
- XLP2 400 Amp
- XLP3 630 Amp

##### 4 - pole:

- SLP00 160 Amp
- SLP1 250 Amp
- SLP2 400 Amp
- SLP3 630 Amp

#### Properties of the EasyLine - XLP:

- Compact XLP000
- Typetested according to EN IEC 60947-3
- Fullfills BGV A2
- Easy to recycle / EN ISO 14001 standards
- Quick-make operation device
- Integrated IP 20 cable termination
- IP 30 degree of protection from the front
- Replacement compatible to similar types in the market
- Voltage measuring from the front
- V-0 plastic materials

#### Advantages of the EasyLine - XLP:

- Easy to install
- Easy to snap on DIN rails
- Easy to operate
- Easy to understand
- Modern cable terminals
- Modern and functional design
- Additional arc protection shroud in front cover - increased personal safety
- Wide range of modern cable clamps and accessories
- Electronic fuse monitoring
- Wide range of busbar adapters

#### Applications of EasyLine - fuse protection:

- Installation
- Switchboards
- Distribution systems
- OEM's



# EasyLine

3 pole XLP000

## XLP000 100 A

- Compact design for NH 000 compact fuses up to 100 A
- Modern integrated cable clamps for 1,5 -35 mm<sup>2</sup> cables
- Integrated cable shrouds IP 20
- Snap on for DIN rail mounting (accessory)
- Front frames for 1 -3 apparatus (accessory)
- Micro auxiliary switches, 1 or 2 pcs (accessory)
- Sealing facility

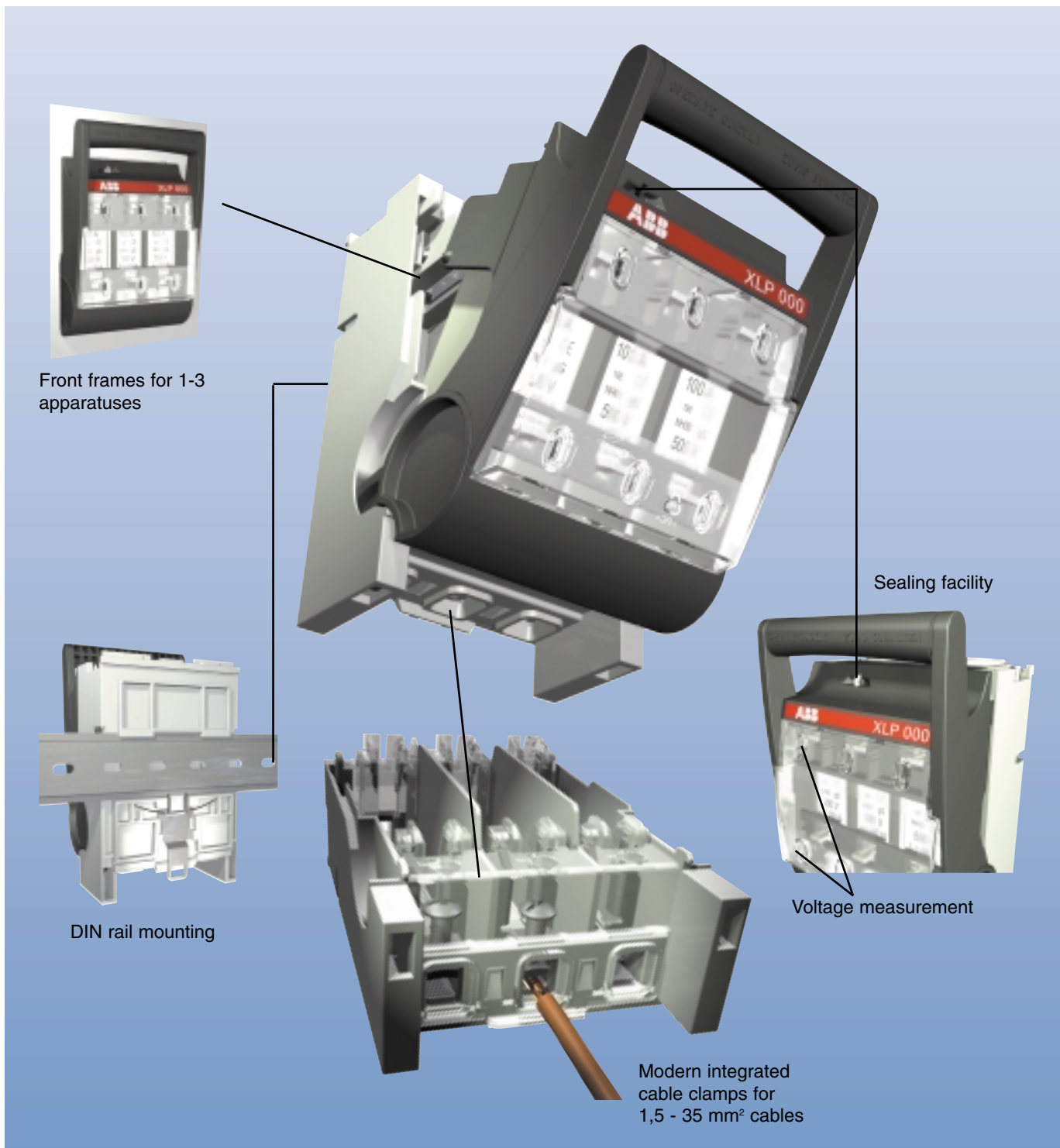

# EasyLine

3 pole XLP00

## XLP00 160A

- Electronic fuse monitoring
- Micro auxilliary switches, 1 or 2 pcs
- Auxilliary swithes, 1 NO or 1 NC acc. to IEC 60947-5-1
- Cable shrouds
- Wide range of cable terminal clamps (See page 12)
- Front frames for 1-3 apparatus
- Kit for double DIN rail mounting
- Different types of plug - in busbar adapter. 40 to 60 mm busbar distance.
- Padlocking facility
- Sealing facility

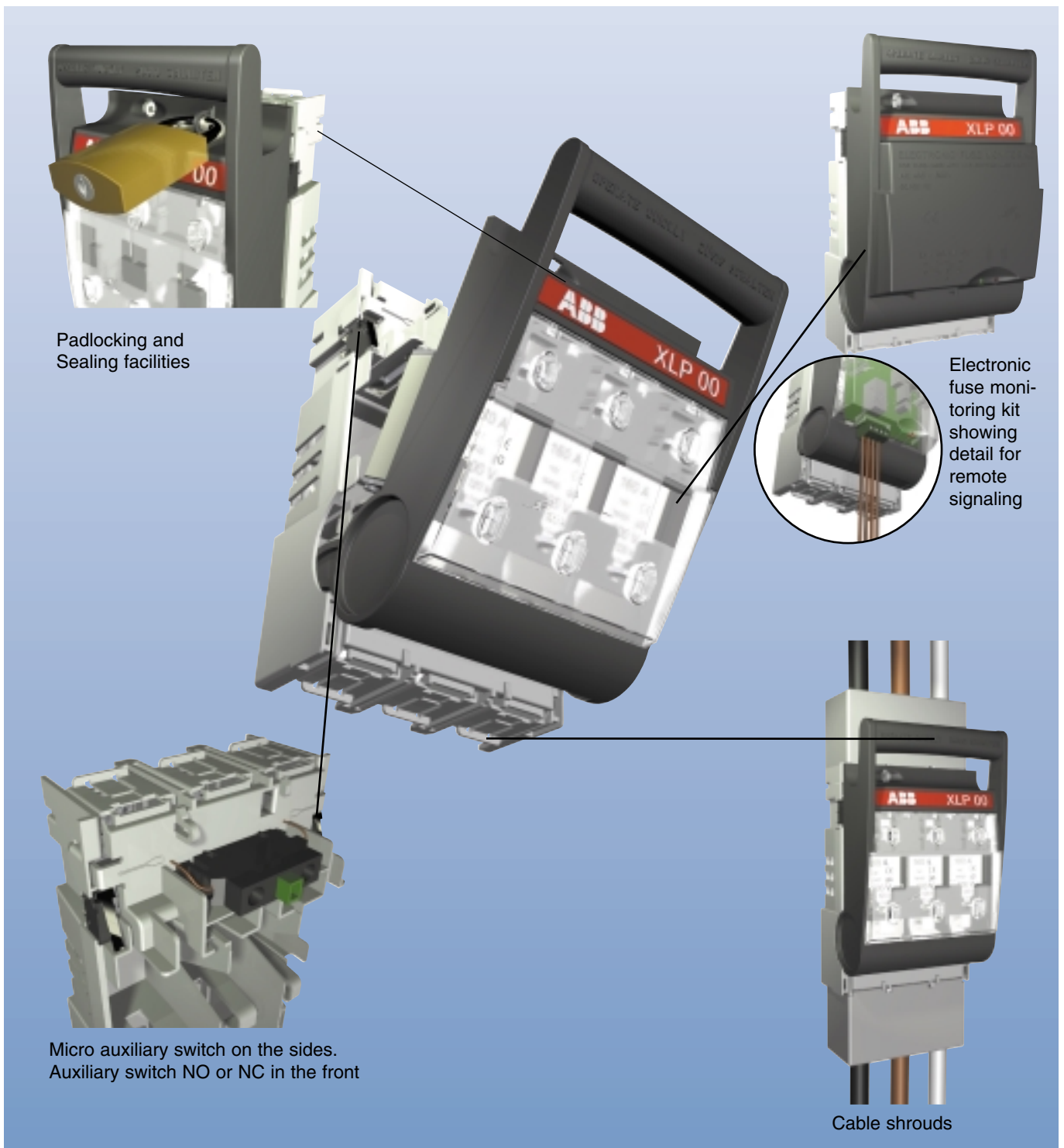

# EasyLine

3 pole XLP1

## XLP1 250 A

- Electronic fuse monitoring
- Micro auxiliary switches, 1 or 2 pcs
- Auxiliary switch, 1 NO or 1NC, acc. to IEC 60947-5-1
- Cable shrouds
- Wide range of cable clamps (See page 12)
- Front frames for 1 - 2 apparatus
- Busbar adapter for 60 mm busbar distance
- Padlocking facility
- Sealing facility



# EasyLine

3 pole XLP2 / 3

## XLP2 / 3 400 / 630 A

- Electronic fuse monitoring
- Micro auxiliary switches, 1 or 2 pcs
- Auxiliary switches , 1 NO or 1NC acc. to IEC 60947-5-1
- Cable shrouds
- Wide range of cable clamps (See page 13)
- Front frame for 1 apparatus
- Padlocking facility
- Sealing facility



## EasyLine

4 pole SLP 00-3

### SLP 4 pole 160 - 630 A

The EasyLine range can offer a 4-pole solution by using SLP 4 pole. The Neutral pole can be equipped with a fuse carrier or a neutral link.

The SLP 4-pole range :

- SLP 00 4-pole Delivered with 8 bridge clamps
- SLP-K 1,2,3 4-pole Delivered without clamps.  
Clamps have to be ordered separately



SLP 00 4 pole



SLP K1 4 pole

# EasyLine

## Electronic Fuse Monitor

### Electronic Fuse Monitor

The fuse monitor is a fuse blown monitoring and indication device. It will be automatically reset after the blown fuse has been replaced and the green LED turns on again.

The matrix below show all possible cases of indication.



Status	EasyLine XLP EFM	LED Green		LED Red		NO contact 13,14		NC contact 11,12	
		illuminated	dark	illuminated	dark	open	closed	open	closed
<b>Fuse Status</b>	<b>Voltage on Phases</b>								
<b>1. Disconnecter closed :</b>									
Fuses OK	Phases OK	x			x	x			x
Fuses BLOWN	Phases OK		x	x			x	x	
Fuses OK	L1 Phase loss	x			x	x			x
Fuses OK	L2-L3 Phases loss (1)		x		x	x			x
Fuses BLOWN	L1 Phase loss		x	x			x	x	
Fuses BLOWN	L2-L3 Phases loss (1)		x		x	x			x
<b>2. Disconnecter open :</b>									
Fuses OK	Phases OK		x		x	x			x
Fuses OK	Phase loss		x		x	x			x
Fuses BLOWN	Phases OK		x		x	x			x
Fuses BLOWN	Phase loss		x		x	x			x

(1) : The case if Phase L2 or L3 or both are lost.

The fuse monitor is connected to the gripping lugs of the fuses.

- NOTE :**
- Insulated gripping lugs can not be used.
  - The fuse monitor requires that the supply side of the XLP should be on top of the switch.

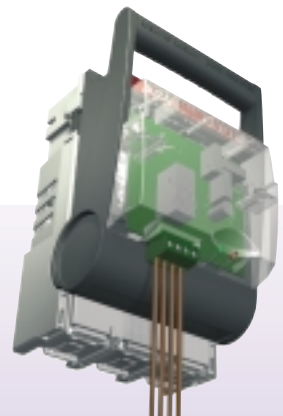

**Technical data :**

Minimum operation voltage:	400V $\pm$ 10%
Maximum operation voltage:	690V +10%
U <sub>imp</sub> over a blown fuse:	12,3 kV
U <sub>imp</sub> between phases:	9.8 kV
U <sub>imp</sub> between main circuit/ relay contacts.:	9.8 kV
Dielectric test voltage input / output:	3.5 kV / 50 Hz / 1 minute
Electrostatic Discharge:	EN61000-4-2 +/- 4 kV
Electrical Fast Transient:	EN61000-4-4 +/- 2 kV
Conducted Fast Transient:	EN61000-4-6 10Vrms / 150kHz – 80 MHz
Connector:	MSTB 2,5/4 - ST - 5,08
Wire size:	AWG 22-12 / 0.2-2.5mm <sup>2</sup>
EMC tested:	Yes

**Relay:**

Nominal current:	8 amp
Nominal switching capacity:	2000VA, AC1
Maximum switching voltage:	440V AC, 250V DC

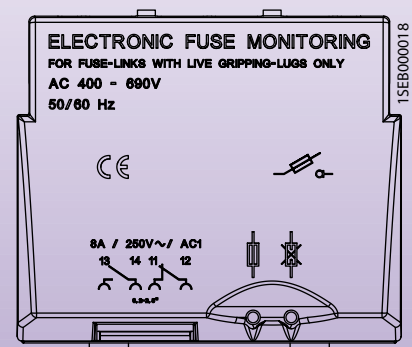

# EasyLine

## System description

### Busbar adapters for XLP00 and XLP1

#### 60 mm Busbar system

Designed for 60 mm busbar distance

Cu/Al 5/10x10,12, 20, 25 or 30 mm.

3 pieces of distance shoes for 5 mm busbars are included with the adapter.

Adapter 60 mm for cable connection below : A 60 - Down

Adapter 60 mm for cable above : A 60 - Up

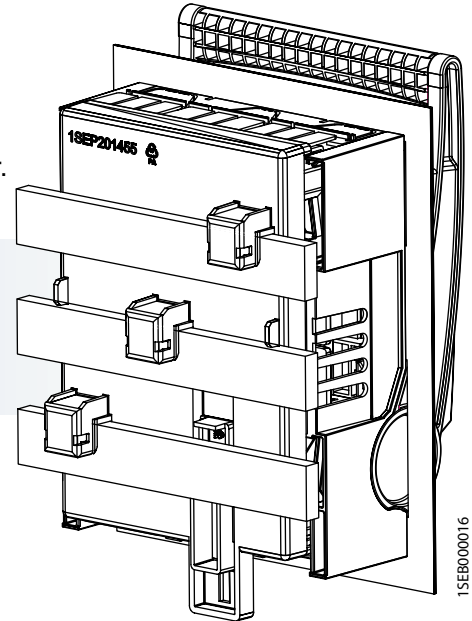

### Distribution system for standard Busbars type SF-60

The busbar system type SF-60 is designed to take busbars of different cross sections, and it is type tested to VDE-0660, section 50 and IEC 439-1.

#### The SF-60 Busbar system features:

Busbar width: 12 - 30 mm  
 Busbar thickness: 5 or 10 mm  
 Centre distance between busbars: 60 mm



#### Explanations :

XLP = Basic Fuse switch disconnecter

Apparatus size

Axx/yy = A : Adapter xx : Busbardist. yy : Depth mm.

6CC = 6 pcs Cage Clamps  
 3BC = 3 pcs Bridge Clamps  
 3TC = 3 pcs Trippel Clamp  
 3FC = 3 pcs Feeding Clamp  
 3M8 = 3 pcs Bolts M8  
 3M10 = 3 pcs bolts M10

Up = Cable connecting above  
 Down = Cable connection below

XLP00 A60/60 3M10 Up

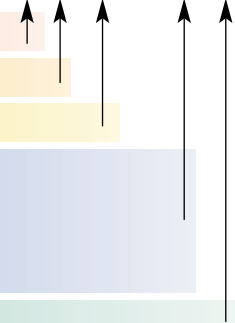

# EasyLine

## System description

### 40 mm Busbar system for XLP00

Cu 12x5 or 12x10 mm.

Adapter 95 mm depth to busbars : A 40/95

### 40 mm Busbar system for Striebel & John switchboards

Specially designed for the Striebel & John Busbar system 250 A and 360 A

Cu 12x5 or 12x10 mm.

Adapter 75 mm depth to busbars, cable connection below : A 40/75

Adapter 120 mm depth to busbars, cable connection below : A 40/120

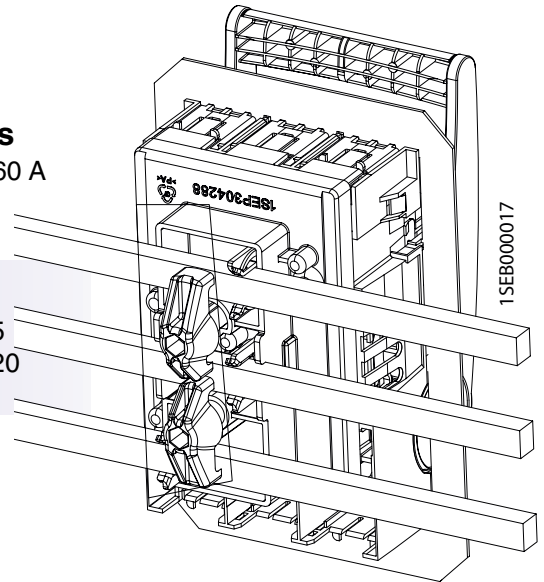



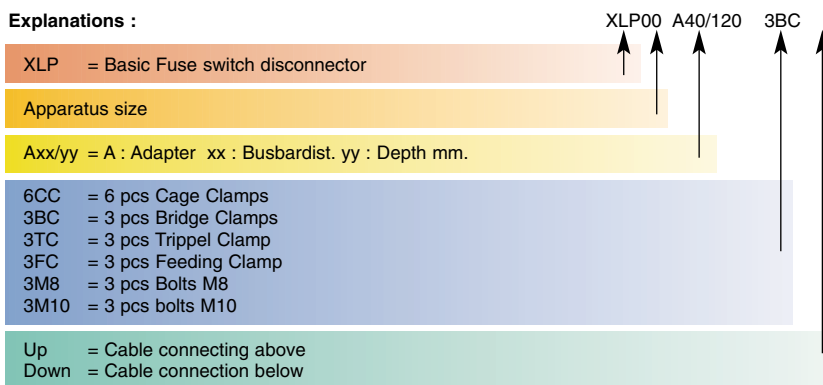









#### Explanations :



# EasyLine

## Cable clamps and bolts



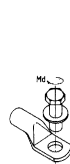

### Cable clamps and bolts

	Type of Clamp/bolt	Conductor cross section min-max					Order Code
		Busbars Height/Width mm	Conductor flexible mm <sup>2</sup>	Rm/Sm mm <sup>2</sup>	Re/Se mm <sup>2</sup>	Torque (Nm) *	
	<b>XLP000</b>						
	Cage Clamps (CC)		1,5-25	1,5 – 35	1,5 – 35	3,2	Included in the switch
	<b>XLP00</b>						
	Bridge Clamp (BC)		1,5-35	1,5 – 50	1,5 – 50	3,5	1SEP407733R0001
	Triple Camp (TC)		1,0-10	1,0 – 10	1,0 – 10	3,5	1SEP407787R0001
	Single Prism Clamp (SPC)		1,5-16	1,5 – 16	1,5 – 16	3,5	1SEP407732R0001
			25 - 50	25 – 70	25 – 70		
	Feeding Clamp (FC) for XLP00 - 6BC		25-70	25 – 95	25 – 95	10	1SEP407811R0001
	Bolt M8x16 DIN 933	4 x 20					
	Bolt M8x16 DIN 933 for Cable lug DIN 46234		10 - 95	10 – 95	10 – 95	10	NHP 400940R0006
	Bolt M8x16 DIN 933 for Cable lug DIN 46235		16 - 70	16 - 70	16 - 70		
	<b>XLP1</b>						
	Bridge Clamp (BC)	10x19	16-70	16-95	16-95	10	1SEP407733R0002
	Single Prism Clamp (SPC)		16-70	16-95	16-95	10	1SEP407732R0002
			95-150	95-150 1)	95-150		
	Double Prism Clamp (DPC)		2x70 – 2x95	2x70 - 2x150	2x70 - 2x150	10	NHP 403631R0001
	Bolt M10x20 DIN933	10x40					
	Bolt M10x20 DIN933 for Cable lug DIN46234		10-240	10-240	10-240	16	NHP 403625R0001
	Bolt M10x20 DIN933 for Cable lug DIN46235		16-240	16-240	16-240		

# EasyLine

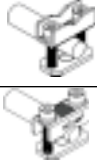
## Cable clamps and bolts

### Cable clamps and bolts

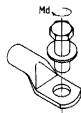
	Type of Clamp/bolt	Conductor cross section min-max					Order Code
		Busbars Height/Width mm	Conductor flexible mm <sup>2</sup>	Rm/Sm mm <sup>2</sup>	Re/Se mm <sup>2</sup>	Torque (Nm) *	
	<b>XLP2/3</b>						
	Bridge Clamp (BC)	26x14	16-70 (M8x25) 300 (M8x40)	16-50 (M8x25) 185-300 (M8x40)	16-95 (M8x25) 185-300 (M8x40)	14	1SEP407953R0001
			70-240	50-185	50-185		
	Single Prism Clamp (SPC)		95-240	70-240	95-240		1SEP407954R0001
			25-95	35-70	50-70		
	Double Prism Clamp (DPC)		2x35 – 2x120	2x35 - 2x150	2x35 - 2x50/ 2x50 - 2x185	22	1SEP407956R0001
	Bolt M12x30 DIN933	50x12				25	NHP 403626R0001
	Bolt M12x30 DIN933 for Cable lug DIN46234		10-240	10-240	10-240		
	Bolt M12x30 DIN933 for Cable lug DIN46235		16-300	16-300	16-300		

Type tested according to standard: EN IEC 60947-1 and DIN VDE 0295.

#### Explanations:

Flexible: Multi stranded  
 Re: Round solid  
 Se: Sector shaped solid  
 Rm: Round stranded  
 Sm: Sector shaped stranded

1) The Sm (sector shaped stranded) 150 mm<sup>2</sup> have to be round formed before inserted in the Prism Clamp.

\*) For correct Torque (Nm) values, please study the installation description delivered with the devices.

# EasyLine

## Technical data

### 3 - pole

		XLP000			XLP00			XLP1		XLP2		XLP3	
Fuse size acc. to DIN 43620 / IEC / EN 60269-2-1		000 Max Width=21mm			00			1		2		3	
Rated operational voltage $U_e$	(V)	400	500	690	400	500	690	500	690	500	690	500	690
Rated operational current $I_e$	(A)	80	100	50	125	160	125	250	200	400	315	630	500
Thermal current w/fuse link $I_{th}$	(A)	100			160			250		400		630	
Rated insulation voltage $U_i$	(V)	690			1000			1000		1000		1000	
Rated impulse withstand voltage $U_{imp}$	(V)	6000			8000			8000		8000		8000	
Fuse protected short circuit making	(kArms)	50			50			50		50		50	
Rated making and breaking capacity :		AC23B	AC22B	AC21B	AC23B	AC22B	AC21B	AC22B	AC21B	AC22B	AC21B	AC22B	AC21B
Rated frequency	(Hz)	50 / 60			50 / 60			50 / 60		50/60		50/60	
Power loss at $I_n$ without fuse-link/phase	(W)	1.4W			3.5W			7.5W		13W		24W	
Electrical durability		300			200			200		200		200	
Mechanical durability		1700			1400			1400		800		800	
Degree of protection from the front acc. to IEC / EN 60529	Open	IP 20			IP 20			IP 20		IP20		IP20	
	Closed	IP 30			IP30			IP 30		IP30		IP30	

### 4 - pole

		SLP00			SLP-K1		SLP-K2		SLP-K3	
Fuse size acc. to DIN 43620 / IEC / EN 60269-2-1		00			1		2		3	
Rated operational voltage $U_e$	(V)	400			400		400		400	
Rated operational current $I_e$	(A)	160			250		400		630	
Rated insulation voltage $U_i$	(V)	1000			1000		1000		1000	
Rated impulse withstand voltage $U_{imp}$	(V)	8000			8000		8000		8000	
Fuse protected short circuit making	(kArms)	50			50		50		50	
Rated making and breaking capacity:		400VAC			AC22B		AC22B		AC22B	
Rated frequency	(Hz)	50 / 60			50 / 60		50 / 60		50 / 60	
Degree of protection from the front acc. to IEC / EN 60529	Open	IP 10			IP 20		IP 20		IP 20	
	Closed	IP 30			IP 30		IP 30		IP 30	

The products are designed and tested in accordance with IEC / EN 60947-3.

Additionally, all development and production activities are in compliance with the Quality System Standard EN ISO 9001 and Environmental Standards EN ISO 14001.

# EasyLine

## Ordering tables XLP



Type Designation	Item Description	Order code	Units Per Package	Weight Per Unit
<b>XLP000</b>				
XLP000-6CC	100 A incl. 6 Cage Clamps	1SEP201428R0001	1	0,46
XLP000-6CC in carton	100 A incl. 6 Cage Clamps in carton	1SEP201428R0002	1	
XLP000-2P-4CC	100 A 2pole incl. 4 Cage Clamps	1SEP201428R0003	1	
XUP000-6CC	100 A Fuse Base incl. 6 Cage Clamps	1SEP201432R0001	1	0,34
<b>XLP00</b>				
XLP00	160 A without clamps or bolts	1SEP101890R0001	1	0,55
XLP00-6BC	160 A incl. 6 Bridge clamps	1SEP101890R0002	1	0,63
XLP00 6BC 3M8	160 A incl. 6 Bridge clamps and 3xM8 bolts	1SEP101890R8002	1	0,65
XLP00-6M8	160 A incl. 6xM8x16 bolts	1SEP101890R0004	1	0,63
XLP00-EFM-6BC	160 A incl. El. Fuse Monitoring incl 6 Bridge Clamps	1SEP101890R0012	1	0,68
XLP00-w/MNS adapter-3BC	160 A with MNS adapter incl. 3 Bridge Clamps	1SEP101890R0402	1	0,88
XLP00-w/MNS adapter-EFM-3BC	160 A with MNS adapter incl. El. Fuse Mon. incl. 3 Bridge Clamps	1SEP101890R0412	1	1,1
XLP00-A60/60-B-3BC-below	160 A incl. A60/60 adapter incl. 3 Bridge Clamps, cable below	1SEP101916R0001	1	0,95
XLP00-A60/60-B below	160 A incl. A60/60 adapter, cable below, without clamps or bolts	1SEP101916R0002	1	0,95
XLP00-A60/60-A-3BC-above	160 A incl. A60/60 adapter incl. 3 Bridge Clamps, cable above	1SEP101917R0001	1	0,95
XLP00-A40/95-B-3BC-below	160 A incl. A40/95 adapter incl. 3 Bridge Clamps, cable below	1SEP101899R0002	1	1,1
XLP00-A40/75-B-3BC-below	160 A incl. A40/75 adapter incl. 3 Bridge Clamps, cable below	1SEP101898R0002	1	1
XLP00-A40/75-B-3M8-below	160 A incl. A40/75 adapter incl. 3 M8 bolts, cable below	1SEP101898R0004	1	1
XLP00-A40/75-A-3BC-above	160 A incl. A40/75 adapter incl. 3 Bridge clamps, cable above	1SEP101898R0102	1	1
XLP00-A40/120-B-3BC-below	160 A incl. A40/120 adapter incl. 3 Bridge Clamps, cable below	1SEP101899R0002	1	1,2
XLP00-A40/120-B-3M8-below	160 A incl. A40/120 adapter incl. 3 M8 bolts, cable below	1SEP101899R0004	1	1,2
XLP00-A40/120-A-3BC-above	160 A incl. A40/120 adapter incl. 3 Bridge clamps, cable above	1SEP101899R0102	1	1,2
XLP00-A40/120-A-3M8-above	160 A incl. A40/120 adapter incl. 3 M8 bolts, cable above	1SEP101899R0104	1	1,2
<b>XLP1</b>				
XLP1	250 A without clamps , bolts	1SEP101891R0001	1	1,6
XLP1-6BC	250 A incl. 6 Bridge Clamps	1SEP101891R0002	1	1,8
XLP1-6M10	250 A incl. 6xM10x20 bolts	1SEP101891R0004	1	1,8
XLP1-EFM-6BC	250 A incl. El. Fuse Monitoring incl 6 Bridge Clamps	1SEP101891R0012	1	1,97
XLP1-A60/85-B-3BC-below	250 A incl. A60/85 adapter incl. 3 Bridge Clamps, cable below	1SEP101918R0001	1	2,47
XLP1-A60/85-A-3BC-above	250 A incl. A60/85 adapter incl. 3 Bridge Clamps, cable above	1SEP101919R0001	1	2,47
XLP1-A40/120-3BC	250 A incl. A40/120 adapter incl. 3 Bridge Clamps	1SEP101912R0002	1	2,8
XLP1-A40/120-3M10	250 A incl. A40/120 adapter incl. 3xM10 bolts	1SEP101912R0004	1	2,75
XUP1	250 A Fuse Base without clamps , bolts	1SEP101895R0001	1	1,1
XUP1-6BC	250 A Fuse Base incl. 6 Bridge Clamps	1SEP101895R0002	1	1,3
<b>XLP2</b>				
XLP2	400 A without clamps , bolts	1SEP101892R0001	1	2,5
XLP2-6BC	400 A incl. 6 Bridge Clamps	1SEP101892R0002	1	3,02
XLP2-EFM-6BC	400 A incl. El. Fuse Monitoring incl 6 Bridge Clamps	1SEP101892R0012	1	3,2
XUP2	400 A Fuse Base without clamps , bolts	1SEP101974R0001	1	
XUP2-6BC	400 A Fuse Base incl. 6 Bridge Clamps	1SEP101974R0002	1	
<b>XLP3</b>				
XLP3	630 A without clamps , bolts	1SEP101975R0001	1	3,7
XLP3-6BC	630 A incl. 6 Bridge Clamps	1SEP101975R0002	1	4,25
XLP3-EFM-6BC	630 A incl. El. Fuse Monitoring incl 6 Bridge Clamps	1SEP101975R0012	1	4,4

### Explanations :

XLP = Basic Fuse switch disconnecter  
 XUP = Basic Fuse base without front cover

Apparatus size

PMNS = Prepared for MNS adapter  
 Axx/yy = A : Adapter xx : Busbardist. yy : Depth mm.

EFM = Electronic Fuse Monitoring

6CC = 6 pcs Cage Clamps ( XLP000 )  
 3BC = 3 pcs Bridge Clamps  
 3TC = 3 pcs Trippel Clamp  
 3FC = 3 pcs Feeding Clamp  
 3M8 = 3 pcs Bolts M8  
 3M10 = 3 pcs Bolts M10

XLP00-PMNS-EFM-3BC

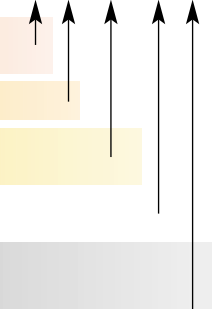

# EasyLine

## Ordering tables Accessories XLP

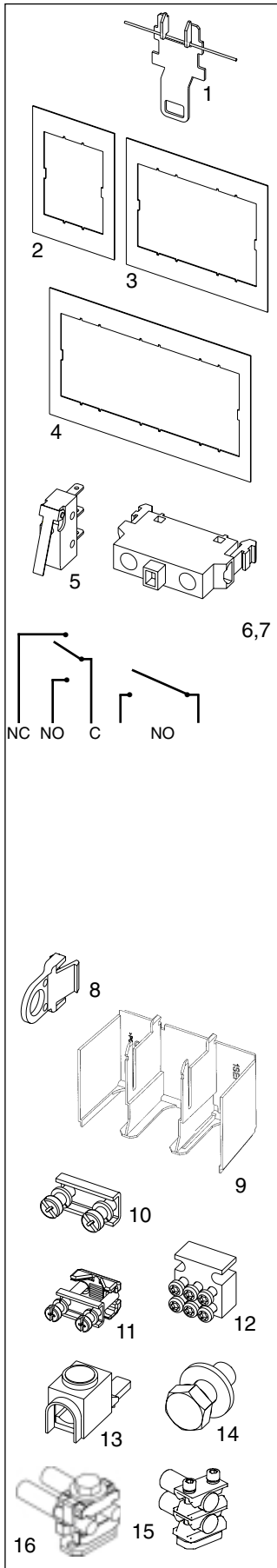

Type Designation	Item Description	Order code	Units Per Package	Weight Per Unit	
<b>Common accessories</b>					
5	Micro auxiliary switch	1SEP407742R0001	1	0,01	
6	Auxiliary switch NC	1SEP407742R0002	1	0,02	
7	Auxiliary switch NO	1SEP407742R0003	1	0,02	
8	Padlock device	1SEP407786R0001	1	0,005	
	XLP000 / SLP00 Bolt ( 3-M8 ) w/ wash.	NHP 400940R0006	3	0,04	
	XLP1 / SLP1 Bolt ( 3-M10 ) w/ wash.	Kit including 3 x Bolts M10x20 mm w/ wash.	3	0,09	
14	XLP2/3, SLP-K2/3 4-pole Bolt ( 3-M12 ) w/ wash.	Kit including 3 x Bolts M12x30 mm w/ wash.	3	0,18	
15	XLP1 / SLP-K 4 P Double Prisme Clamp ( 3-DPC )	2x70-150mm <sup>2</sup>	1	0,15	
	XLP1 / SLP1 Front fixing bracket w/ frame	NHP 403635R0001	1		
<b>Accessories XLP000</b>					
	XLP000 Front cover ( spare part )	1SEP304222R0001	1	0,12	
1	XLP000 DIN rail snap on kit-Size 1 pc	1SEP407740R0001	1	0,006	
	XLP000 DIN rail snap on kit -Qty. 10 pc	1SEP407740R0010	10	0,06	
2	XLP000 Frontframe for 1 XLP000	1SEP407741R0001	1	0,02	
3	XLP000 Frontframe for 2 XLP000	1SEP407741R0002	1	0,025	
4	XLP000 Frontframe for 3 XLP000	1SEP407741R0003	1	0,03	
<b>Accessories XLP00</b>					
	XLP00 Front cover ( spare part )	1SEP101873R0001	1	0,17	
	XLP00 A60/60 Adapter above	For 60 mm busbar distance, 5 or 10 mm, cable above	1SEP101910R0001	1	0,38
	XLP00 A60/60 Adapter below	For 60 mm busbar distance, 5 or 10 mm, cable below	1SEP101915R0001	1	0,38
	XLP00 A40/75 Adapter above / below	For 40 mm busbarsystem Striebel & John, cable above or below	1SEP101909R0001	1	
	XLP00 A40/120 Adapter above / below	For 40 mm busbarsystem Striebel & John, cable above or below	1SEP101909R0002	1	
	XLP00 Front cover with EFM	Front cover with Electronic fuse monitoring	1SEP101873R0007	1	0,09
	XLP00 Front fixing bracket with front frame		1SEP201534R0001	1	
	XLP00 Frontframe f / 1 XLP00		1SEP407792R0001	1	0,02
	XLP00 Frontframe f / 2 XLP00		1SEP407792R0002	1	0,03
	XLP00 Frontframe f / 3 XLP00		1SEP407792R0003	1	0,04
	XLP00 ABB-INS Frontframe f / 1 XLP00		1SEP407792R0004	1	
	XLP00 ABB-INS Frontframe f / 2 XLP00		1SEP407792R0005	1	
	XLP00 1,5mm distance plate f.S&J		1SEP408220R0001	1	
9	XLP00 Cable shroud	1SEP407793R0001	1	0,03	
	XLP00 Snap for double DIN rail	1SEP407897R0001	1	0,24	
10	XLP00 Bridge Clamp ( 3-BC )	1,5-50mm <sup>2</sup>	3	0,04	
12	XLP00 Triple Clamp ( 3-TC )	1,0-10mm <sup>2</sup>	3	0,15	
11	XLP00 Single Pris.Clamp ( 3-SPC )	1,5-70mm <sup>2</sup>	3	0,09	
13	XLP00 Feeding Clamp ( 3-FC )	25 - 95 mm <sup>2</sup>	3	0,29	
<b>Accessories XLP1</b>					
	XLP1 Front cover ( spare part )	1SEP101883R0001	1	0,5	
	XLP1 A60/85 Adapter-above	For 60 mm busbar distance, 5 or 10 mm, cable above	1SEP201451R0001	1	0,74
	XLP1 A60/85 Adapter-below	For 60 mm busbar distance, 5 or 10 mm, cable below	1SEP201456R0001	1	0,74
	XLP1 Front cover with EFM	Front cover with Electronic fuse monitoring	1SEP101883R0007	1	0,37
	XLP1 Frontframe f / 1 XLP 1		1SEP407815R0001	1	0,04
	XLP1 Frontframe f / 2 XLP 1		1SEP407815R0002	1	0,06
	XLP1 Cable shroud		1SEP407793R0002	1	0,1
10	XLP1 Bridge Clamp ( 3-BC )	16-95mm <sup>2</sup>	3	0,11	
11	XLP1 Single Prisme Clamp ( 3-SPC )	16-185mm <sup>2</sup>	3	0,17	
<b>Accessories XLP2/3</b>					
	XLP2 Front cover ( spare part )	1SEP101982R0001	1	0,65	
	XLP2 Frontframe f / 1 XLP2		1SEP407951R0001	1	0,4
	XLP2 Frontframe f / 2 XLP2		1SEP407951R0002	1	
	XLP2 Front cover with EFM	Front cover with Electronic fuse monitoring	1SEP101982R0007	1	0,25
	XLP3 Front cover ( spare part )		1SEP101984R0001	1	0,9
	XLP3 Frontframe f / 1 XLP3		1SEP407955R0001	1	0,055
	XLP3 Front cover with EFM	Front cover with Electronic fuse monitoring	1SEP101984R0007	1	0,35
	XLP2/3 Cable shroud		1SEP407952R0001	1	0,18
10	XLP2/3 Bridge Clamp ( 3-BC )	35-300mm <sup>2</sup>	3	0,26	
11	XLP2/3 Sing.Prisme Clamp ( 3-SPC )	25-240mm <sup>2</sup>	3	0,5	
16	XLP2/3 Double Pris. Clamp ( 3-DPC )	2x35-150mm <sup>2</sup> sm	3	0,36	

# EasyLine

## Ordering tables

### SLP 4-pole

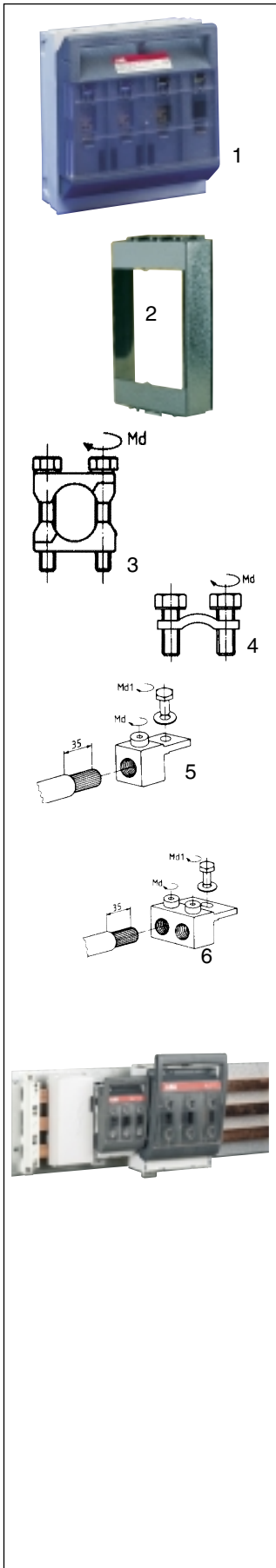

Type Designation	Item Description	Order code	Units Per Package	Weight Per Unit
<b>SLP 4 pole</b>				
SLP00 4 pole	160A	NHP 100844R0001	1	1,2
1 SLP-K1 4 pole	250A	NHP 100799R0001	1	4
SLP-K2 4 pole	400A	NHP 100838R0001	1	7,6
SLP-K3 4 pole	630A	NHP 100838R0002	1	8,1
<b>SLP 4 pole Accessories</b>				
SLP00 Cover IP 30 4 pole		NHP 100991P0001	1	0,04
2 SLP-K1 Cover IP 30 4 pole		NHP 100993P0001	1	0,06
SLP-K2/3 Cover IP 30 4 pole		NHP 100992P0001	1	0,06
<b>SLP Cable clamps</b>				
3 SLP-K1 Single cable clamp 70 - 150 mm <sup>2</sup>		NHP 403628R0002	1	0,1
SLP-K1 Single cable clamp 16 - 150 mm <sup>2</sup>		NHP 403627R0002	1	0,1
4 SLP-K2/3 Single cable clamp 16 - 240 mm <sup>2</sup>		NHP 403677R0002	1	0,24
5 SLP-K2/3 Single cable clamp, Al / Cu 95 - 240 mm <sup>2</sup>		NHP 403630R0002	1	0,15
6 SLP-K2/3 Double cable clamp, Al / Cu 2x95 - 240 mm <sup>2</sup>		NHP 403633R0002	1	0,3

### SF-60 Busbar system

Type Designation	Item Description	Order code	Units Per Package	Weight Per Unit
Busbar carrier 3P	5-10 x 12-30 mm	GHV 240849R0001	1	10,1
Cover f/busbar carrier		GHV 240849R0004	1	0,03
Cable connection supply module	5-10 x 12-30 mm	GHV 240849R0034	1	0,62
Cover for cable connection module		GHV 204849R0036	1	0,15

# EasyLine

## Dimensional Drawings XLP Basic Apparatus

### XLP000

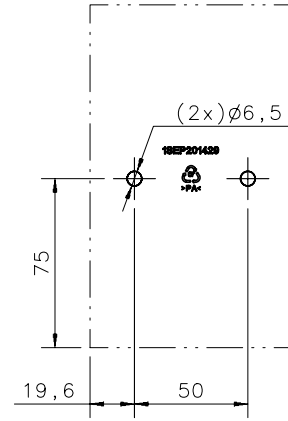
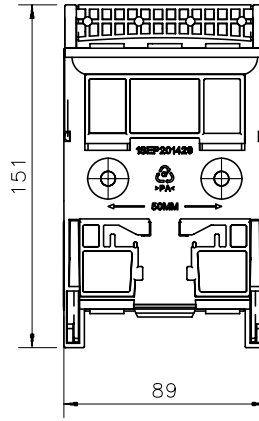
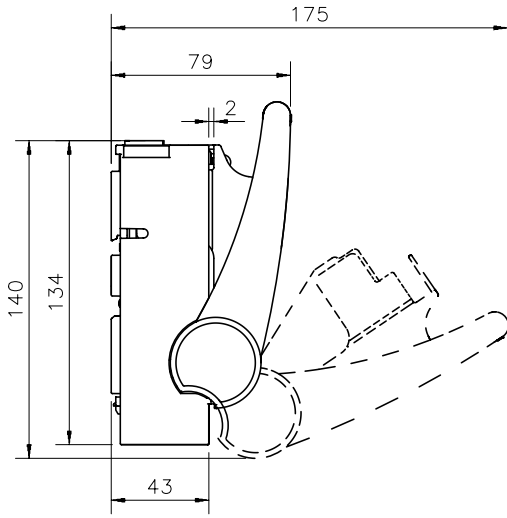

1SEB000001

### XLP00

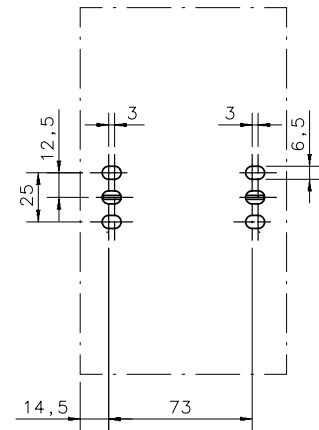
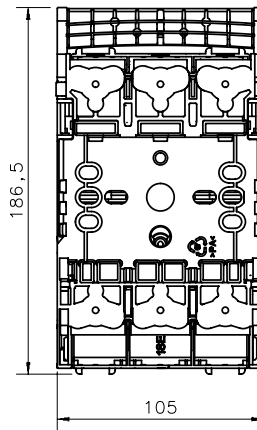
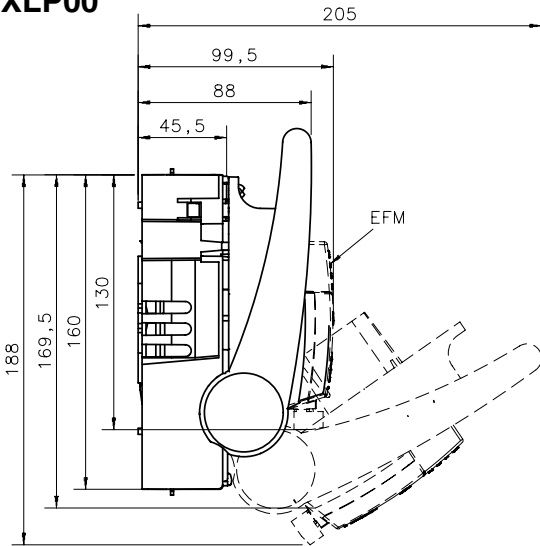

1SEB000008

### XLP1

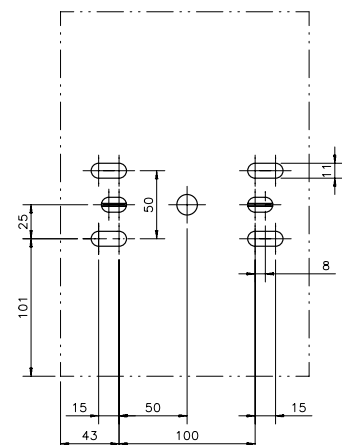
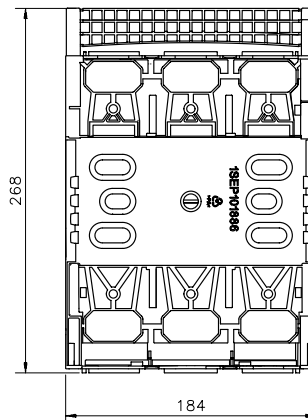
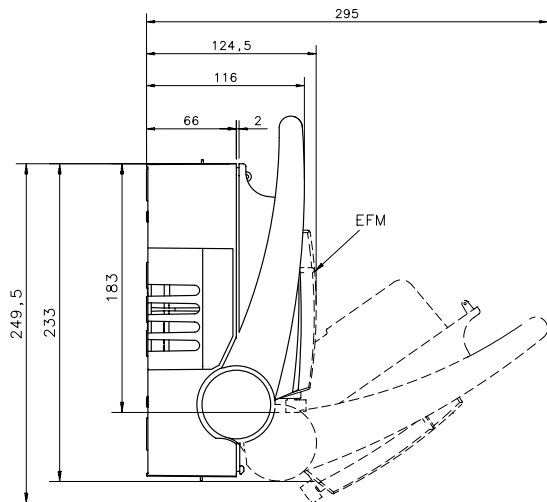

1SEB000002

# EasyLine

## Dimensional Drawings XLP Basic Apparatus

### XLP2

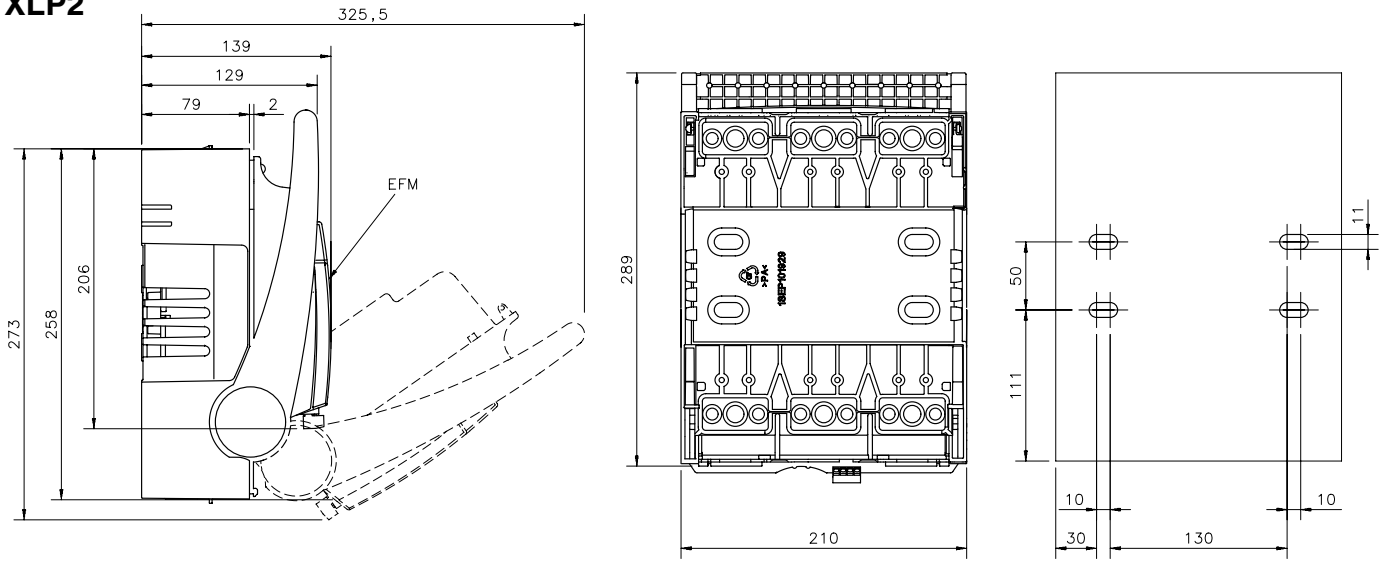

1SEB000003

### XLP3

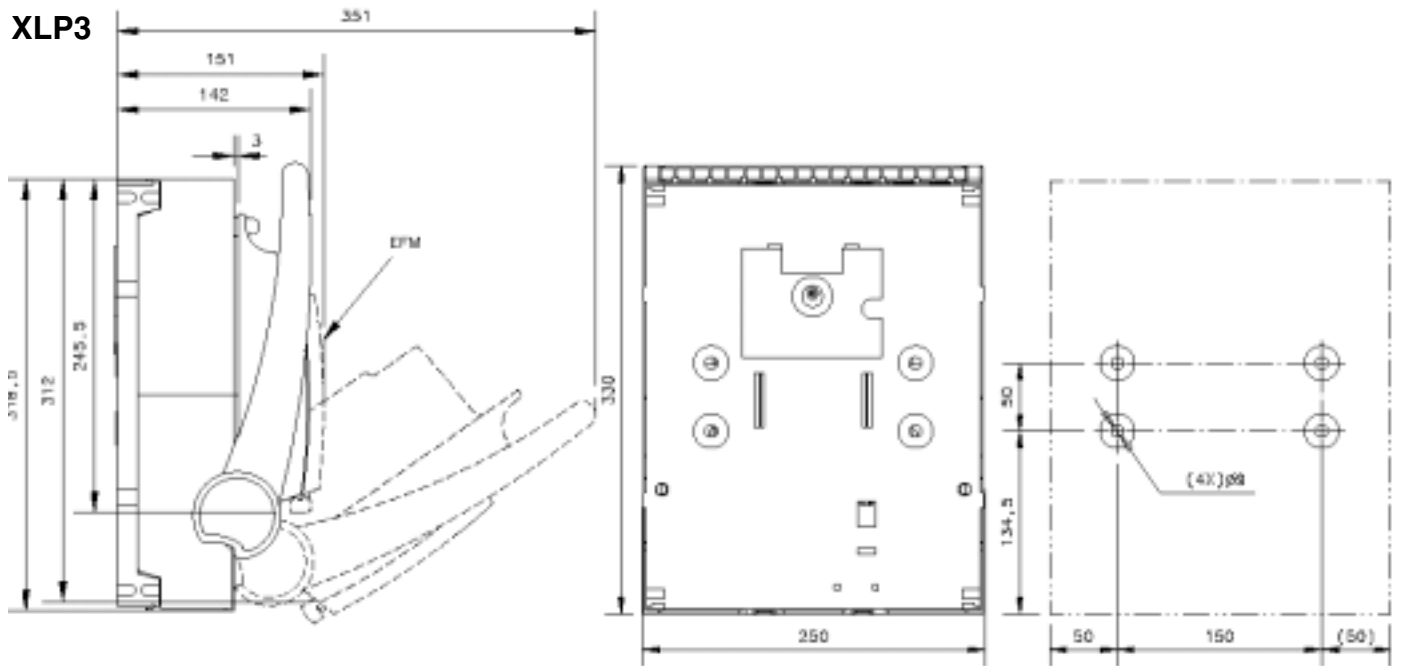

1SEB000004

# EasyLine

## Dimensional Drawings XLP with Adapters

**XLP00 – A40/75**

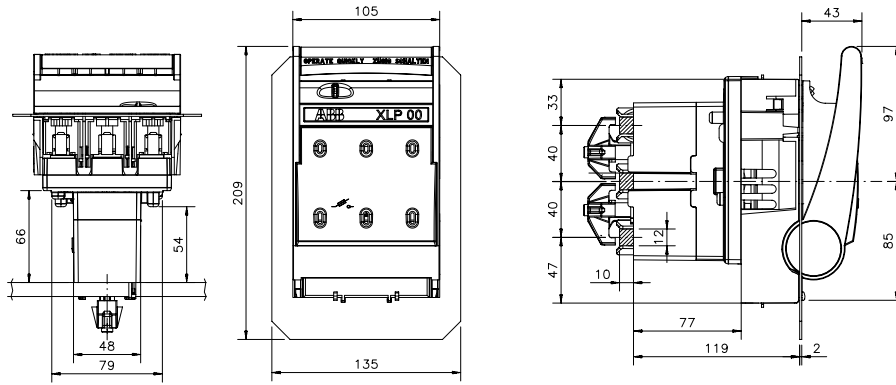

1SEB000005

**XLP00 – A40/95**

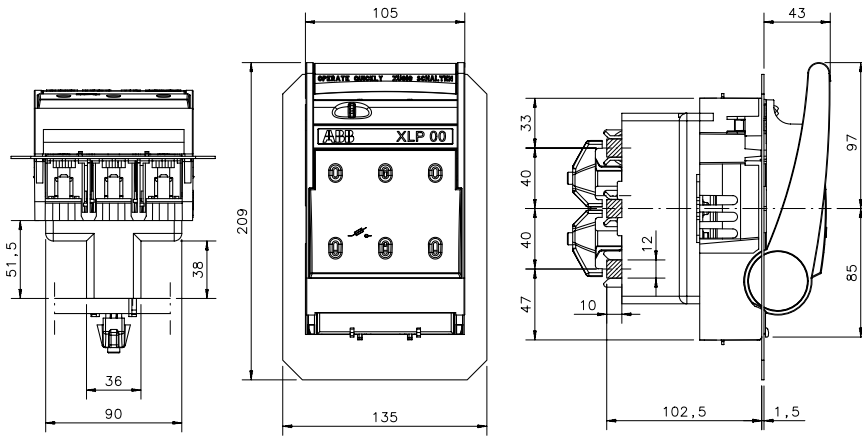

1SEB000117

**XLP00 – A40/120**

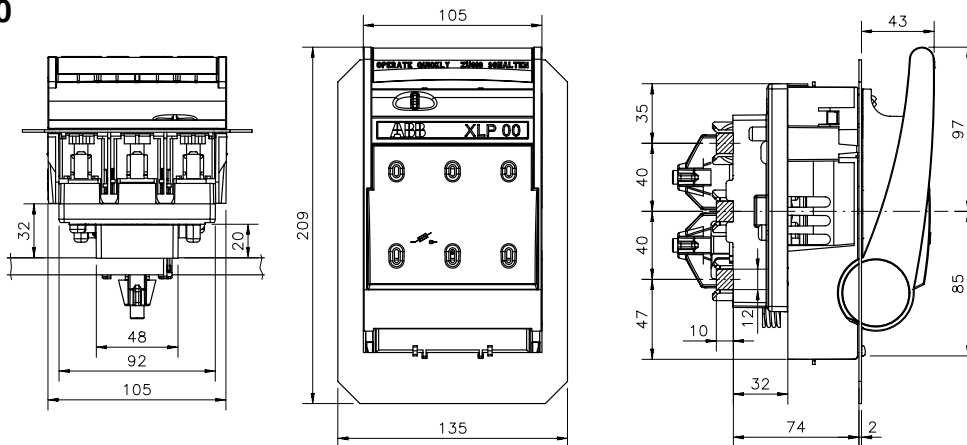

1SEB000006

**XLP00 – A60/60**

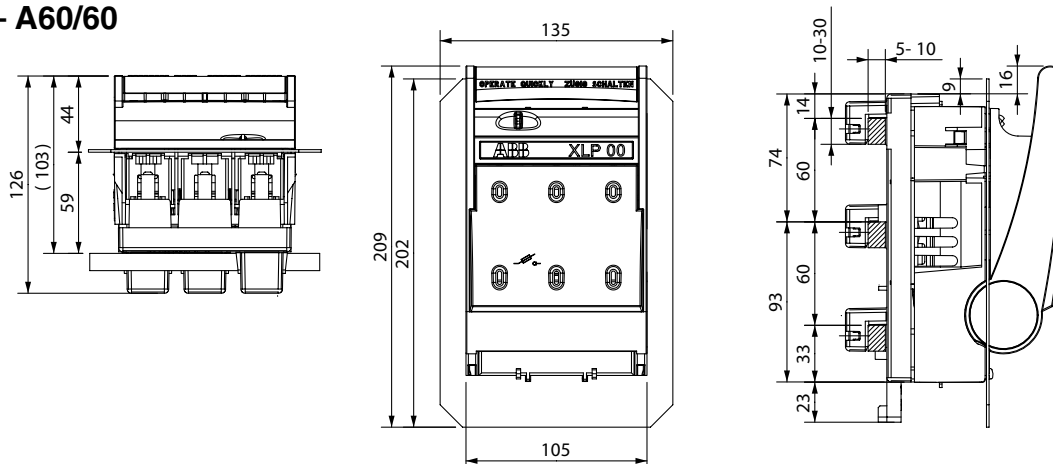

1SEB000007

# EasyLine

## Dimensional Drawings XLP with Adapters

### XLP1 – A60/85

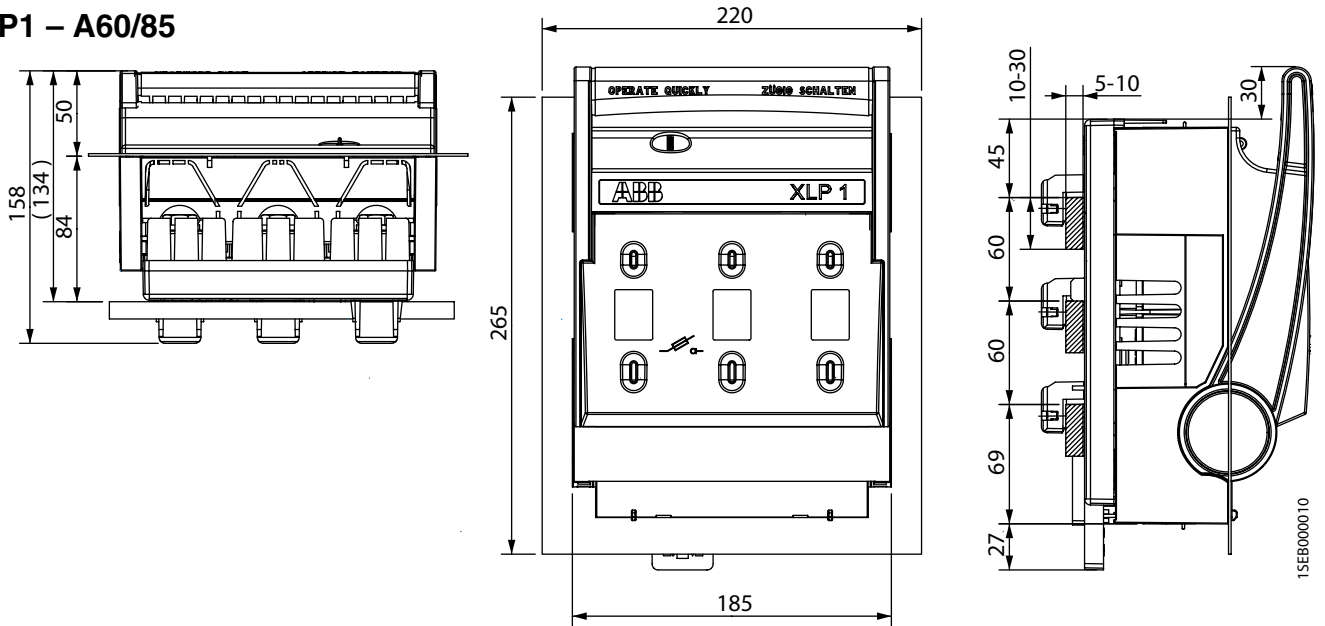

### XLP1 – A40/120

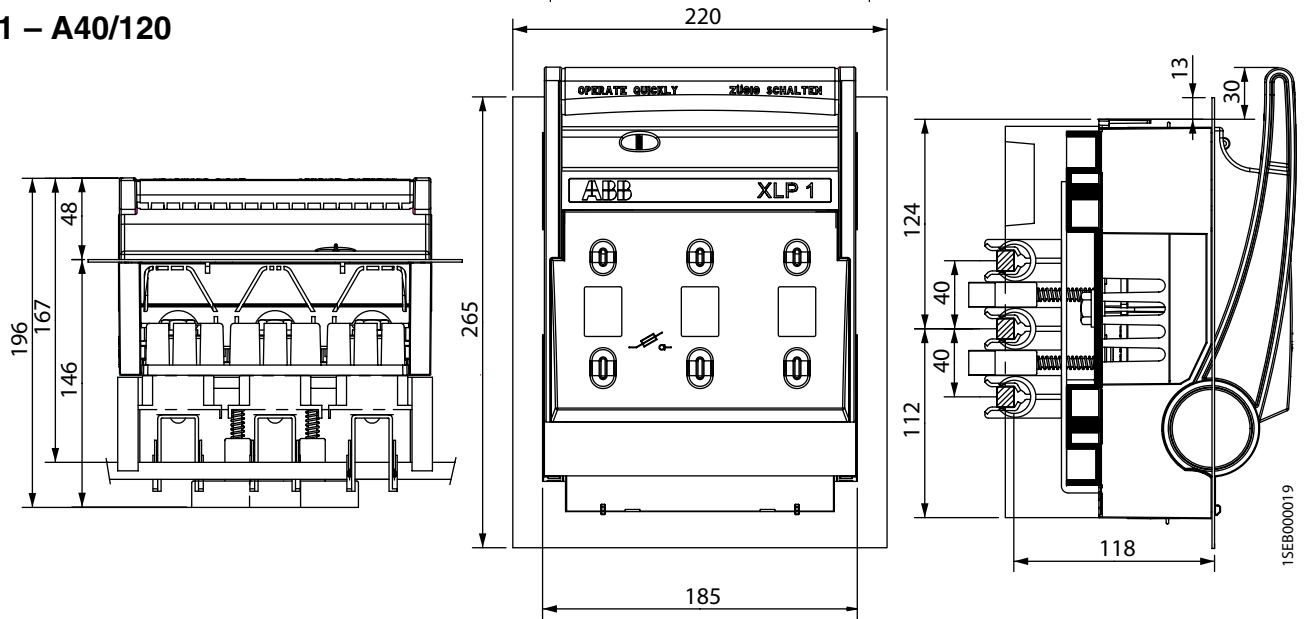

### SF-60 System

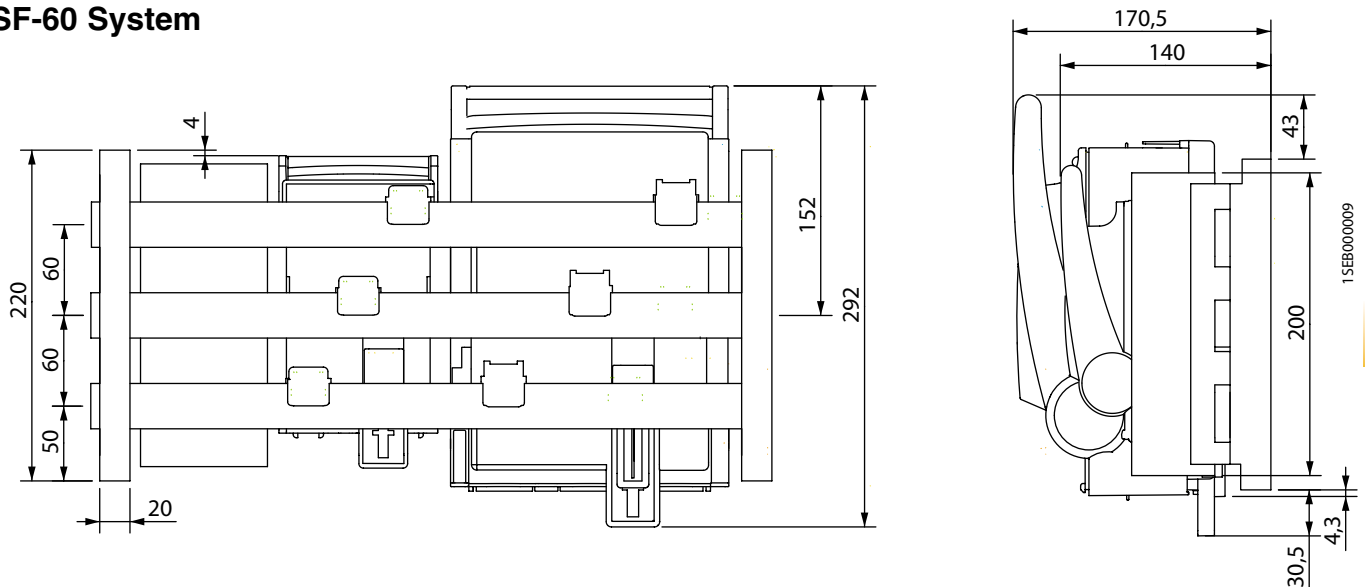



# EasyLine

## Dimensional Drawings

**SLP00 4 pole**

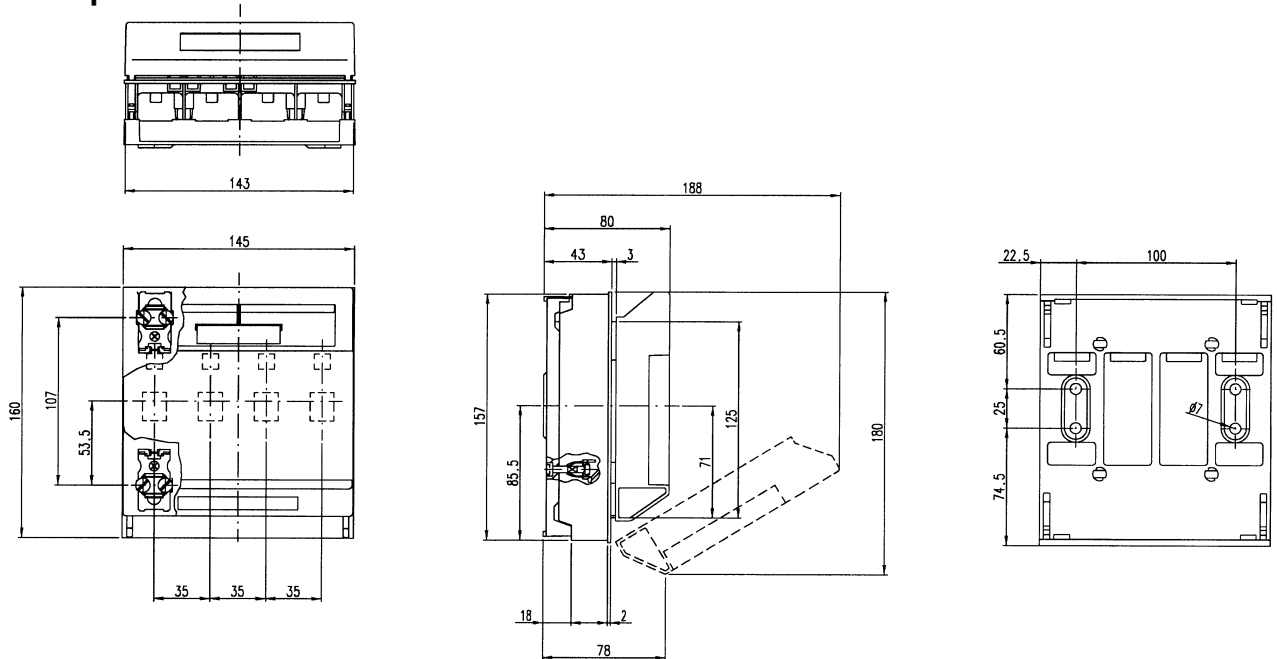

NHP30398

**SLP-K1 4 pole**

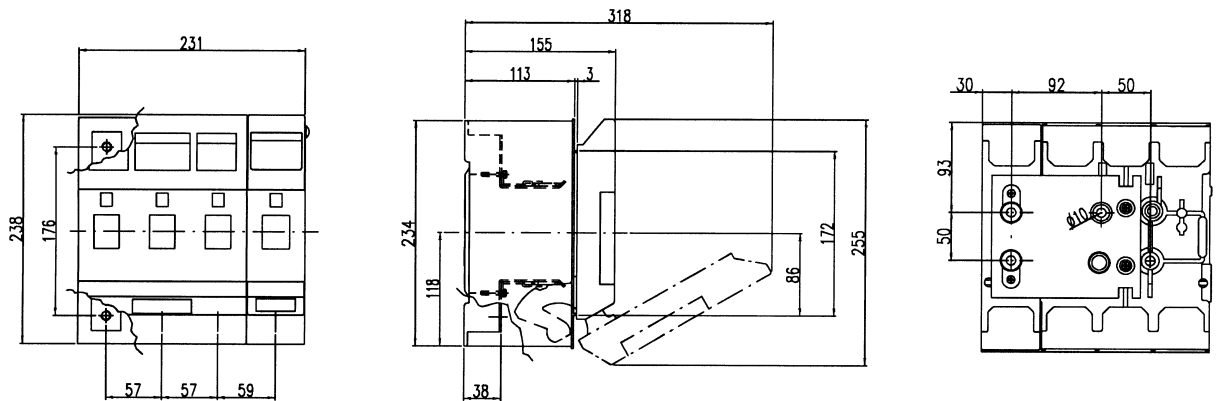

NHP30399

**SLP-K2/3 4 pole**

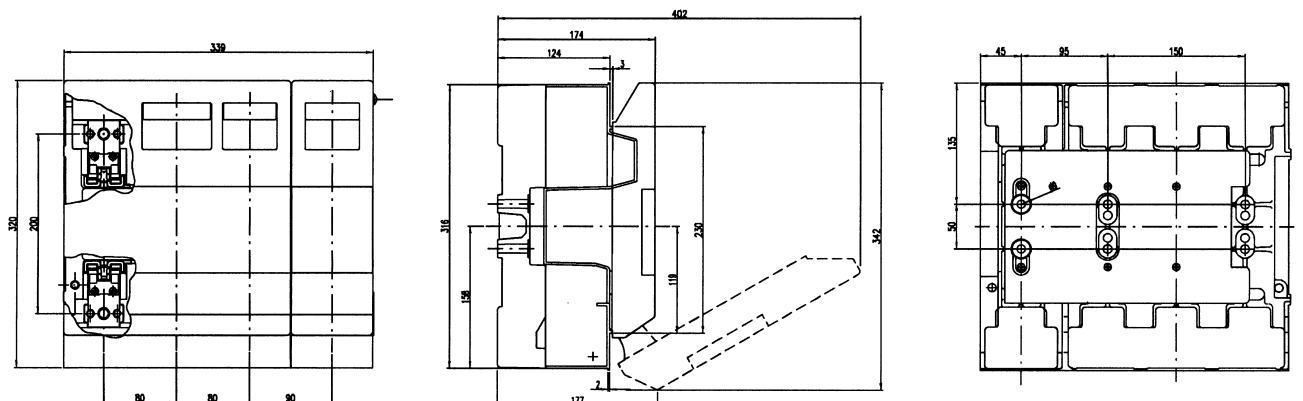

NHP303408







As part of its on-going product improvement, ABB reserves the right to modify the characteristics or the products described in this brochure. The information given is not-contractual. For further details please contact the ABB company marketing these products in your country.

---

**ABB AS**

Low Voltage Products  
Automation Products Division  
P.O. Box 100, Sentrum,  
N-3701 Skien, Norway  
Telephone +47 35 58 25 00  
Telefax +47 35 58 28 00  
[www.abb.com/lowvoltage](http://www.abb.com/lowvoltage)