

Technical catalogue

System pro M compact[®] and other modular devices for low voltage installation

2CSC400002D0206 Edition 2007-2008



ABB

SUMMARY

Introduction	1	
Miniature circuit-breakers	2	
Residual current devices	3	
Auxiliary elements and accessories	4	
Other modular devices	Surge protective devices: OVR range	5
	Protection devices	6
	Command devices	7
	Load management devices	8
	Measurement devices	9
	Other functions	10
Technical details	11	
Application sheets	12	
Overall dimensions	13	
Worldwide marks and approvals	14	

“New entries”

The extension of the RCBOs DS9 range with the introduction of the new AP-R type resistant to unwanted trippings

∴ NEW



Completion of the high performances RCDs with the introduction of the DDA800 100A and the DS800 125A.

∴ NEW



A new range of staircase lighting time delay switches to combine the high simplicity of use with a new silent, accurate and reliable electrical motor

∴ NEW

∴ NEW ENTRIES

NEW ENTRIES

"New entries"

A new range of analogue time switches available both in daily and weekly versions, in 1, 2 or 3 modules and with or without running reserve

∴ **NEW**



A new range of digital time switches with new functionalities such as random mode, waiver mode and holiday mode, EEPROM memory and programming key

∴ **NEW**



Four different devices to cover different needs: accuracy in the brightness range (TW1), high values of Lux for daylight applications (TW2-10K), pole mounting installations (TWP) and absence of the external sensor in places subjected to high level of pollution or vandalic acts (TWA)

∴ **NEW**



System pro

1



A wide product range suitable for all applications in residential, industrial and commercial installations.

Thanks to the compatibility between the new System pro *M* compact range and the System pro *M* range, ABB offers many additional functionalities like:

- protection and switching
- checking and monitoring
- control and programming.

Shape and dimensions of the new series allow both precise adapting in already existing installations and continuity in

terms of profile and appearance.

Time saving in cross-wiring within groups and combinations of devices is another advantage.

The technologically innovative bidirectional cylinder-lift terminal enables synchronous closing of the front and rear wiring input.

Highest safety standard for the installer thanks to protection against electric shock according to EN 41140.

Marking of devices is reliable and clear.

Both supply and connection with busbars from top or bottom is admitted.

The System pro *M* compact range

■ MCBs:

- new circuit-breakers

■ RCDs:

- new residual current circuit-breakers (RCCBs)
- new RCD-blocks
- new residual current circuit-breakers with overcurrent protection (RCBOs)

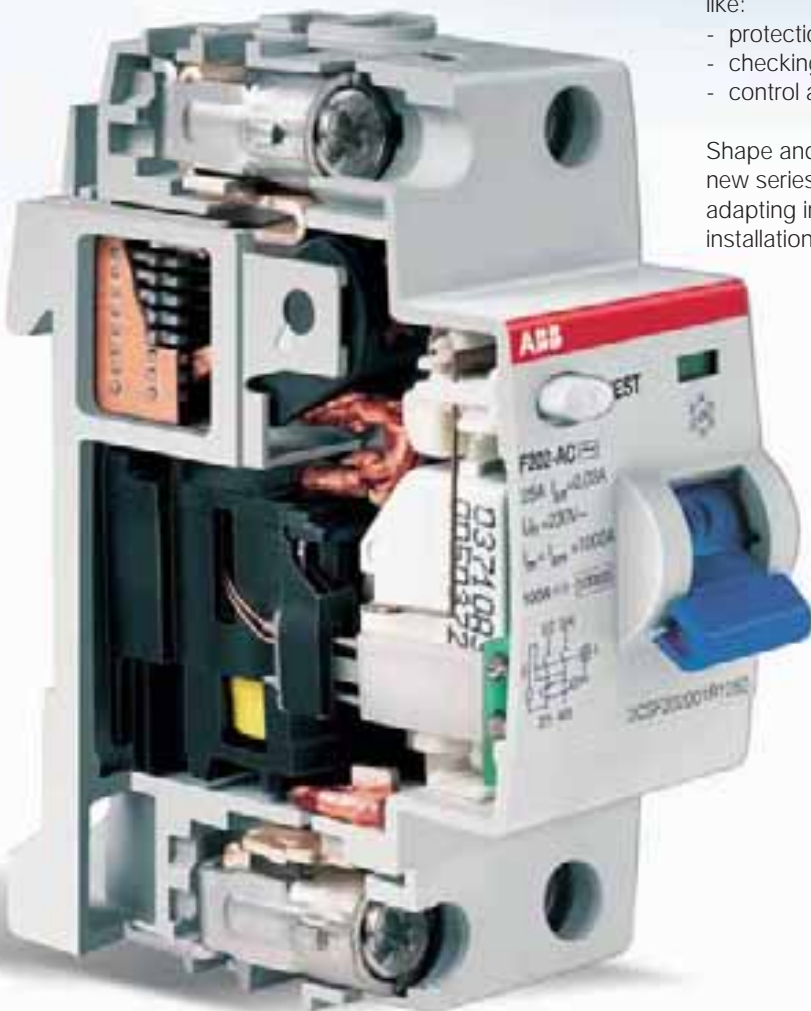

M compact



■ **Auxiliary elements:**

- new universal signal contact switch/auxiliary switch
- new auxiliary switch for circuit-breaker extensions
- new shunt trip
- new undervoltage release

■ **MDRCs-Surge protective devices**

■ **MDRCs-Protection devices**

In addition to MCBs and RCDs, ABB supplies other modular devices for protection such as residual current relays and fuse holders.

■ **MDRCs-Command devices**

This category includes devices that are operated manually to command the electric system: contactors, latching relays, switch-isolators, switches, pushbuttons etc. Typically they are installed to control lights from several points of the same circuit or to pilot user devices with a high number of operations.

■ **MDRCs-Load management devices**

Overload relays, load management switches, anti black-out lamps, time switches and the other modular devices in this

category react automatically to variations of parameters and other events in the system to allow for plant optimisation.

■ **MDRCs-Measurement devices**

The range of devices in this category is very wide, including a great number of auxiliary components and accessories that make installation in switchboards and consumer units practical and economic.

■ **MDRCs-Other devices**

The range of ABB MDRCs also includes bells, transformers etc.

■ **Various accessories**

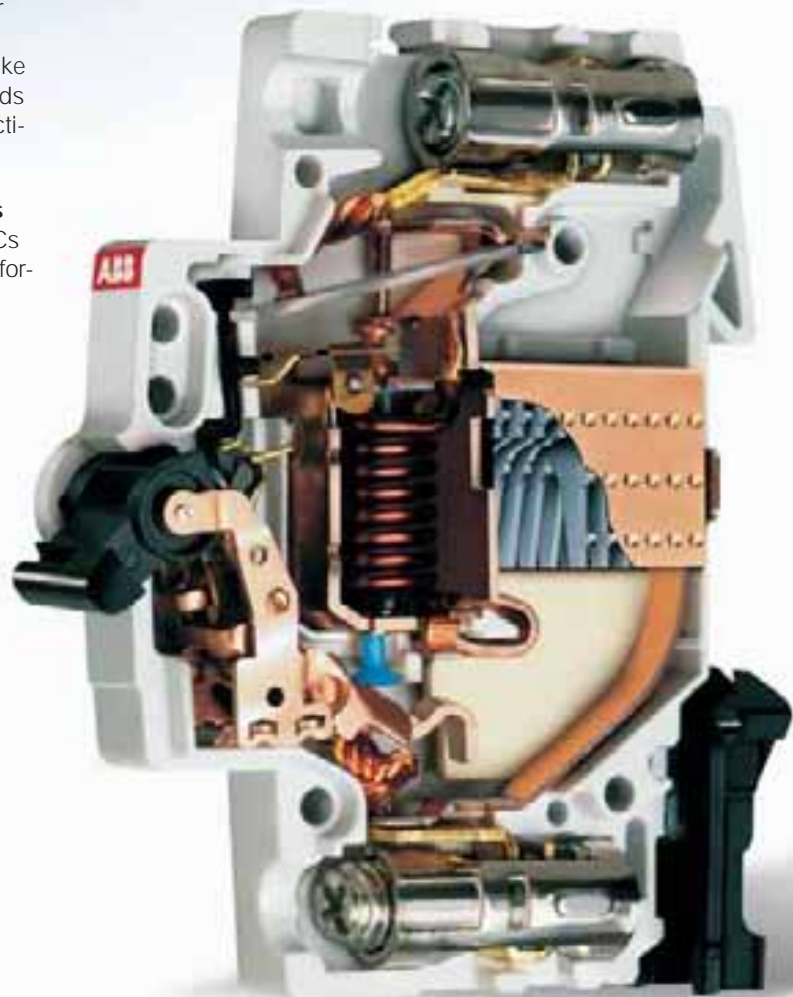

System pro

1



2CSC400259F0201

MCBs are also available with an integrated auxiliary contact (1 NO or 1 NC). Existing installations can be easily upgraded to include auxiliary switch functionality.



2CSC400192F0201

Availability of a quite wide range of factory fitted RCBOs.



2CSC400114F0001

RCD-blocks DDA 200 2P, 3P, 4P up to 40 A fit into two modules. Versions in 63 A sizes are supplied with two additional terminals for remote tripping.



2CSC400229F0001

Universal signal/auxiliary and auxiliary contacts fit on S 200, F 200 and DS 200.



2CSC400131F0201

Without busbars two terminal spaces can be used for cables with different cross sections: incoming supply with supplementary terminal up to 50 mm² from the front side.



2CSC400225F0001

Safety connections between DDA 200 and S 200 thanks to a safe plastic key system.



2CSC400270F0201

Special quick fastening for an easy removal of the devices from the assembly pressing upwards, both for MCBs S 200 and RCCBs F 200: the only in the market that can be removed without a screwdriver.



2CSC400553F0001

More working space between component rows.

System pro M compact[®]



2CSC400132F0001

Supply from top or bottom either with cables or busbars.



2CSC400230F0001

Safe terminal technology: the terminals offer protection from misconnection.

New System pro M compact range is compatible with the System pro M range, thanks to the configuration of new vs old terminals.





2CSC400133F0201



2CSC400395F0201



2CSC400259F0201



2CSC400556F0201

Index

General features and breaking capacities 2/2

S 200 System pro *M* compact MCBs 2/4

S 9.. MCBs 1P+N in 1 module 2/46

S 280, S 290 and S800 MCBs 2/54

System pro M compact® and breaking capacities

MCBs

NOTE: All the MCBs of S200 series present two values of breaking capacities marked on the product:
 on the front I_{cn} according to IEC/EN 60898 on the side I_{cu}/I_{cs} according to IEC/EN 60947-2 depending on the rated current.
 Value of breaking capacity of S2 K, Z characteristics marked on the front of the MCBs, refers to the standard VDE 0660.

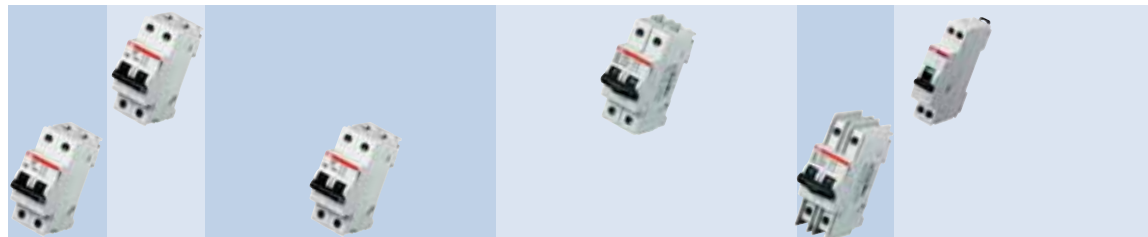









Series		S 200	S 200 M	S 200 P			S 200 U			S 200 UP	S 931N		
Characteristics		B,C,D,K,Z	B,C,D,K,Z	B,C,D,K,Z	B,C,D,K,Z	B,C,D,K,Z	K,Z	K,Z	K,Z	K,Z	C		
Rated current	[A]	$0.5 \leq I_n \leq 63$	$0.5 \leq I_n \leq 63$	$0.5 \leq I_n \leq 25$	$32 \leq I_n \leq 40$	$50 \leq I_n \leq 63$	$0.5 \leq I_n \leq 25$	$32 \leq I_n \leq 40$	$50 \leq I_n \leq 63$	$0.2 \leq I_n \leq 25$	$2 \leq I_n \leq 40$		
Breaking capacity	[kA]												
Reference standard	poles Ue[V]												
IEC 23-3/EN 60898	Icn 230/400	6	10	25	15	15					3		
IEC/EN 60947-2	Icu 1, 1P+N	133	20	25	40	25	25	40	25	25	40	6	
		230	10	15	25	15	15	25	15	15	25	4.5	
		2, 3, 4 230	20	25	40	25	25	40	25	25	40		
		400	10	15	25	15	15	25	15	15	25		
	2, 3, 4	500											
		690											
		Ics 1, 1P+N	133	15	18.7	20	18.7	18.7	20	18.7	18.7	20	4.5
			230	7.5	11.2	12.5	11.2	7.5	12.5	11.2	11.2	12.5	3
	2, 3, 4	230	15 ^①	18.7	20	18.7	18.7	20	18.7	18.7	20		
		400	7.5	11.2	12.5	11.2	7.5	12.5	11.2	11.2	12.5		
IEC/EN 60947-2	Icu 1	24	20										
		60	10	10	15	10	10	15	10	10	15	6	
		220											
		250											
T=I/R≤5ms for all series, except for S280 UC series and S800S-UC series where T=I/R<15ms	2	48	20										
		125	10	10	15	10	10	15	10	10	15	6	
		440											
		500											
	3,4	750											
		Ics 1	24	20									
			60	10	10	15	10	10	15	10	10	15	6
			2	220									
250													
	2	48	20										
		125	10	10	15	10	10	15	10	10	15	6	
	3,4	440											
		500											
	3,4	750											
		Int. 1, 1P+N	120	10		10	10	10					
UL 1077/ C22.2 No 235	cap.		277	6		10	10	10					
		2, 3, 4 240	10		10	10	10						
Alternate current	480 Y/277	6			10	10	10						
		UL 1077/ C22.2 No 235	Int. 1, 1P+N	60	10								
Direct current	UL 489/ C22.2 No 5	cap.	2, 3, 4 125	10									
			120					10	10	10	10		
Alternate current	480 Y/277	277											
		2, 3, 4 240						10	10	10	10		
		480 Y/277								10			

① only up to 40 A; 10 kA up to 50/63 A
 ② only for "D" characteristic
 ③ values are not for all rated currents

System pro M compact® and breaking capacities

MCBs

2

																
S 941N	S 951N	S 971N	S 280	S 280 UC		S 290	S800 S			S800 N						
B,C	B,C	B,C	B,C	B,K,Z		C,D,K	B,C,D	K	KM	UCB	UCK	B,C,D				
$2 \leq I_n \leq 40$	$2 \leq I_n \leq 40$	$2 \leq I_n \leq 40$	$80 \leq I_n \leq 100$	$0.5 \leq I_n \leq 40$	$50 \leq I_n \leq 63$	$80 \leq I_n \leq 125$	$10 \leq I_n \leq 125$	$10 \leq I_n \leq 125$	$20 \leq I_n \leq 63$	$10 \leq I_n \leq 125$	$10 \leq I_n \leq 125$	$10 \leq I_n \leq 125$				
							50	50	50	50	50	36				
4.5	6	10	6			10	25					25				
10	15	20	15	10	6											
6	10	10	6	6	4.5	20 (15) ②	50	50	50			36				
			10	10	6	25										
			6	6	4.5	20 (15) ②	50	50	50			36				
							15 ③	15 ③	15 ③			10 ③				
							6 ③	6 ③	6 ③			4.5				
6	10	10	15	7.5	6											
4.5	6	7.5	6	6	4.5	10 (7.5) ②	40	40	40							
			10	7.5	6	12.5										
			6	6	4.5	10 (7.5) ②	40	40	40			30				
							11 ③	11 ③	11 ③			8 ③				
							4 ③	4 ③	4 ③			3				
10	15	15	10			25										
				6	4.5						50	50				
10	15	15	10													
				6	4.5						50	50				
											50	50				
10	15	15	10			12.5										
				6	4.5						50	50				
10	15	15	10													
				6	4.5						50	50				
											50	50				
							14									
							5	14								
							14									
							5	14								
							0.4									
							0.6									

MCBs protect installations against overload and short-circuit, warranting reliability and safety for operations.

New System pro *M* compact S 200 series satisfies most common requirements in terms of MCBs, allowing the usage of them for domestic, industrial and commercial applications.

Three series – **S 200**, **S 200 M** and **S 200 P** – with three different breaking capacities up to 25 kA are available, in all characteristics (B, C, D, K and Z) and configurations (1P, 1P+N, 2P, 3P, 3P+N and 4P), in all the sizes up to 63 A.

All these MCBs comply to IEC/EN 60898 and IEC/EN 60947-2 Standards. The range includes also the new **S 200 U** and **S 200 UP** in accordance to UL 489/CSA-C22.2 N 05 Standard.

It is also available the new integrated auxiliary contact on the bottom side which permits to save 50% space.

Thought to be advanced, MCBs range also offers all the “plus” advantages which characterized the whole new System pro *M* compact range.

S 200 series devices obtained a lot of marks and approvals, so they can be used in all world's markets.

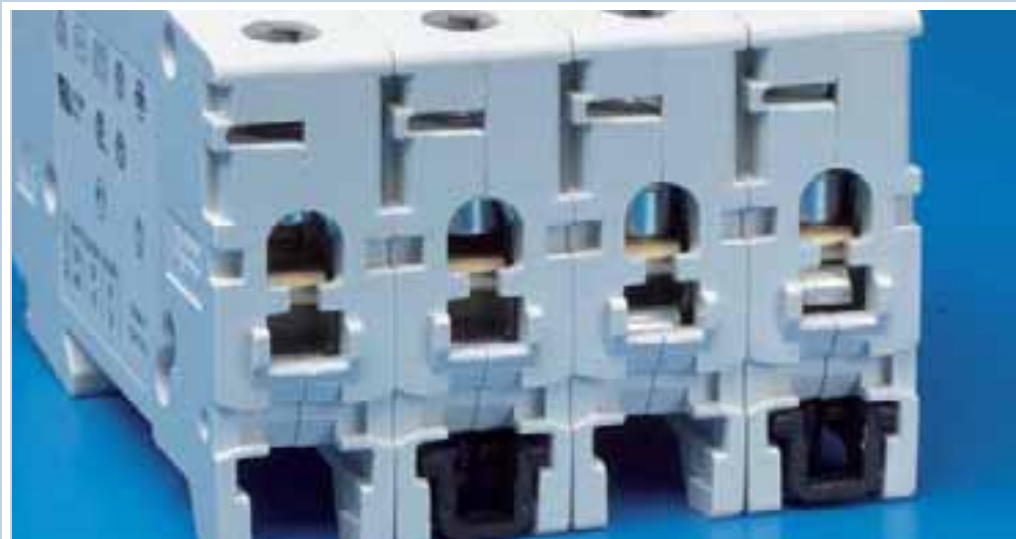

2CSC400230F0201



2CSC400261F0201



2CSC400260F0201



2CSC400259F0201

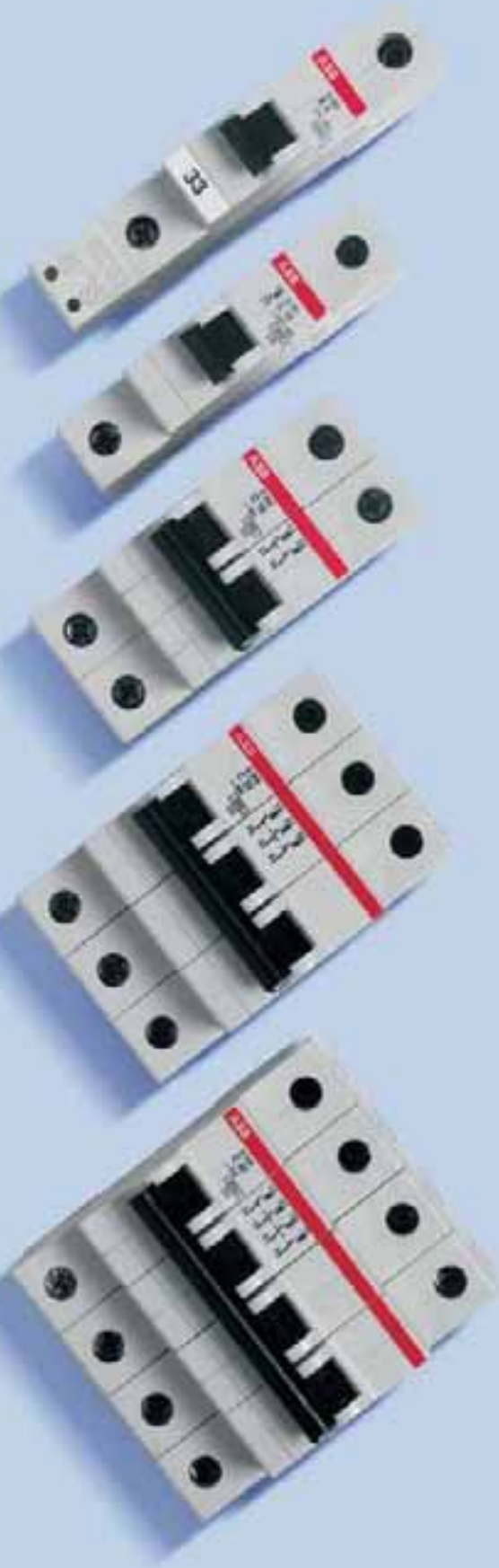

Index

Technical features of MCBs S 200 series 2/6

Selection tables of MCBs S 200 series

S 200-B	2/8
S 200-C	2/10
S 200-D	2/12
S 200-K.....	2/14
S 200-Z.....	2/16
S 200 M-B.....	2/18
S 200 M-C	2/20
S 200 M-D	2/22
S 200 M-K.....	2/24
S 200 M-Z.....	2/26
S 200 P-B	2/28
S 200 P-C.....	2/30
S 200 P-D.....	2/32
S 200 P-K	2/34
S 200 P-Z	2/36

Selection tables of MCBs S 200 in accordance to UL 489/CSA-C22.2 N 05

S 200 U-K	2/38
S 200 U-Z	2/40
S 200 UP-K	2/42
S 200 UP-Z.....	2/44

Standards			
Electrical features	Rated current I_n	A	
	Poles		
	Rated voltage U_e	IEC 1P, 1P+N	V
		IEC 2P, 3P, 3P+N, 4P	V
		UL/CSA 1P, 1P+N	V
		UL/CSA 2P, 3P, 3P+N, 4P	V
	Insulation voltage U_i	V	
	Max. operating voltage U_b max.	IEC AC	V
		UL/CSA AC	
		IEC/UL/CSA DC 1P	V
		IEC/UL/CSA DC 2P	V
	Min. operating voltage U_b min.	V	
	Rated frequency	Hz	
	Rated breaking capacity acc. to IEC/EN 60898	ultimate I_{cn}	A
	Rated breaking capacity acc. to IEC/EN 60947-2	ultimate I_{cu}	kA
		service I_{cs}	kA
	1P, 1P+N @ 230 VAC 2P, 3P, 3P+N, 4P@ 400 VAC		
Rated impulse withstand voltage (1.2/50) U_{imp}		kV	
Dielectric test voltage at ind. freq. for 1 min.		kV	
Overvoltage category			
Pollution degree			
Thermomagnetic release characteristic	B: $3 I_n \leq I_m \leq 5 I_n$ C: $5 I_n \leq I_m \leq 10 I_n$ D: $10 I_n \leq I_m \leq 20 I_n$ K: $10 I_n \leq I_m \leq 14 I_n$ Z: $2 I_n \leq I_m \leq 3 I_n$		
Mechanical features	Toggle		
	Electrical life		
	Mechanical life/operations		
	Protection degree/operations	housing terminals	
	Mechanical shock resistance		
	Resistance to vibrations acc. to IEC/EN 60068-2-6		
	Tropicalization acc. to IEC/EN 60068-2	humid heat	°C/RH
		constant climatic conditions	°C/RH
		variable climatic conditions	°C/RH
	Reference temperature for setting of thermal element		°C
Ambient temperature (with daily average $\leq +35$ °C)	IEC ②	°C	
Storage temperature		°C	
Installation	Terminal type		
	Terminal size top/bottom for cable	IEC	mm ²
		UL/CSA	AWG
	Terminal size top/bottom for busbar	IEC	mm ²
		UL/CSA	AWG
	Tightening torque	IEC	N*m
		UL/CSA	in-lbs.
Tool			
Mounting			
Mounting position			
Connection			
Dimensions and weight	Pole dimensions (H x D x W)		mm
	Pole weight		g
Combination with auxiliary elements	Combinable with:	auxiliary contact signal contact/auxiliary switch shunt trip undervoltage release	

① supplementary protection

② branch circuit protection

③ for S 200 acc. to UL 1077: -25...+70 °C

④ prior to connection of aluminium conductors (≥ 4 mm²) ensure that their contact points are cleaned, brushed and coated with grease



S 200	S 200 M	S 200 P			S 200 U	S 200 UP
IEC / EN 60898, IEC / EN 60947-2, VDE 0641 Part 11, UL 1077 ①, CSA 22.2 No. 235 ②					UL 489 ③, CSA22.2 No.5 ④, IEC/EN 60947-2	
0.5 ≤ In ≤ 63	0.5 ≤ In ≤ 63	0.5 ≤ In ≤ 25	32 ≤ In ≤ 40	50 ≤ In ≤ 63	0.5 ≤ In ≤ 63	0.2 ≤ In ≤ 25
		1P, 1P+N, 2P, 3P, 3P+N, 4P			1P, 2P, 3P, 4P	
120 - 240 - 277 480Y/277		230 - 240 230/400 - 240/415 120 - 240 - 277 480Y/277			120- 240 120- 240	120 - 240 - 277 480Y/277
480Y/277		250 254/440 480Y/277 60VDC 125VDC			240	480Y/277
12VAC - 12VDC					12VAC	
6000	10000	25000	50...60 15000	15000	-	-
10	15	25	15	15	10	10
7.5	11.2	12.5	11.2	11.2	7.5	7.5
			5			
			2.8			
			III			
			2			
■	■	■	■	■	■	■
■	■	■	■	■	■	■
■	■	■	■	■	■	■
■	■	■	■	■	■	■
black sealable in ON-OFF position						
10000						
20000						
IP4X						
IP2X						
30 g - 3 shocks - duration 11 ms						
5 g - 20 cycles at frequency 5...150...5 Hz with load 0.8 In						
28 cycles with 55/95...100						
23/83 - 40/93 - 55/20						
25/95 - 40/95						
30 (20 for characteristics K,Z)					25	
-25...+55						
-40...+70						
failsafe bi-directional cylinder-lift terminal (shock protected) ⑤						
25/25						
18-4						
10/10						
18-8						
2.8						
25						
Nr. 2 Pozidriv						
on DIN rail EN 60715 (35 mm) by means of fast clip device						
optional						
from top and bottom						
125	85 x 68 x 17.5			140	88 x 68 x 17.5	100 x 68 x 17.5
			yes			
			yes			
			yes			
yes					no	

6000

B

2



2CSC400411F0201



2CSC400413F0201



2CSC400415F0201



2CSC400413F0201



S 200 B characteristic

Function: protection and control of the circuits against overloads and short-circuits; protection for people and big length cables in TN and IT systems.

Applications: residential, commercial and industrial.

Standard: IEC/EN 60898, IEC/EN 60947-2

I_{cn}=6 kA

Number of poles	Rated current	Order details	Bbn 4016779	Price 1 piece	Price group	Weight 1 piece	Pack unit
In A	Type code	Order code	EAN			kg	pc.
1	6	S 201-B 6	2CDS 251 001 R0065	46490 1		0.125	10
	10	S 201-B 10	2CDS 251 001 R0105	46380 5		0.125	10
	13	S 201-B 13	2CDS 251 001 R0135	46500 7		0.125	10
	16	S 201-B 16	2CDS 251 001 R1165	57863 9		0.125	10
	20 ①	S 201-B 20	2CDS 251 001 R0205	46510 6		0.125	10
	25	S 201-B 25	2CDS 251 001 R0255	46520 5		0.125	10
	32 ②	S 201-B 32	2CDS 251 001 R0325	46530 4		0.125	10
	40 ③	S 201-B 40	2CDS 251 001 R0405	46540 3		0.125	10
	50	S 201-B 50	2CDS 251 001 R0505	55092 5		0.125	10
	63	S 201-B 63	2CDS 251 001 R0635	55093 2		0.125	10
U _{Bmax} 253 V ~ 72 V ...							
2	6	S 202-B 6	2CDS 252 001 R0065	46640 0		0.250	5
	10	S 202-B 10	2CDS 252 001 R0105	46660 8		0.250	5
	13	S 202-B 13	2CDS 252 001 R0135	46670 7		0.250	5
	16	S 202-B 16	2CDS 252 001 R0165	46690 5		0.250	5
	20	S 202-B 20	2CDS 252 001 R0205	46700 1		0.250	5
	25	S 202-B 25	2CDS 252 001 R0255	46710 0		0.250	5
	32	S 202-B 32	2CDS 252 001 R0325	46720 9		0.250	5
	40	S 202-B 40	2CDS 252 001 R0405	46740 7		0.250	5
	50	S 202-B 50	2CDS 252 001 R0505	55094 9		0.250	5
	63	S 202-B 63	2CDS 252 001 R0635	55095 6		0.250	5
U _{Bmax} 440 V ~ 125 V ... ④							
3	6	S 203-B 6	2CDS 253 001 R0065	46860 2		0.375	1
	10	S 203-B 10	2CDS 253 001 R0105	46870 1		0.375	1
	13	S 203-B 13	2CDS 253 001 R0135	46890 9		0.375	1
	16	S 203-B 16	2CDS 253 001 R0165	46900 5		0.375	1
	20 ①	S 203-B 20	2CDS 253 001 R0205	46910 4		0.375	1
	25	S 203-B 25	2CDS 253 001 R0255	46920 3		0.375	1
	32 ②	S 203-B 32	2CDS 253 001 R0325	46930 2		0.375	1
	40 ③	S 203-B 40	2CDS 253 001 R0405	46940 1		0.375	1
	50	S 203-B 50	2CDS 253 001 R0505	55096 3		0.375	1
	63	S 203-B 63	2CDS 253 001 R0635	55097 0		0.375	1
U _{Bmax} 440 V ~							
4	6	S 204-B 6	2CDS 254 001 R0065	52895 5		0.500	1
	10	S 204-B 10	2CDS 254 001 R0105	52896 2		0.500	1
	13	S 204-B 13	2CDS 254 001 R0135	52897 9		0.500	1
	16	S 204-B 16	2CDS 254 001 R0165	52898 6		0.500	1
	20	S 204-B 20	2CDS 254 001 R0205	52899 3		0.500	1
	25	S 204-B 25	2CDS 254 001 R0255	52900 6		0.500	1
	32	S 204-B 32	2CDS 254 001 R0325	52901 3		0.500	1
	40	S 204-B 40	2CDS 254 001 R0405	52902 0		0.500	1
	50	S 204-B 50	2CDS 254 001 R0505	55098 7		0.500	1
	63	S 204-B 63	2CDS 254 001 R0635	55099 4		0.500	1
U _{Bmax} 440 V ~ 125 V ... ④							

① suitable for flow-type heaters 12 kW
② suitable for flow-type heaters 18 kW

③ suitable for flow-type heaters 21, 24 and 27 kW
④ U_{Bmax} 125 V ... with 2 poles connected in series

6000

B

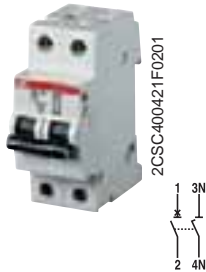

With disconnecting neutral NA

Number of poles	Rated current	Order details	Bbn 4016779	Price 1 piece	Price group	Weight 1 piece	Pack unit
	In A	Type code	Order code	EAN		kg	pc.
1	6	S 201-B 6 NA	2CDS 251 103 R0065	53158 0		0.250	5
+	10	S 201-B 10 NA	2CDS 251 103 R0105	53159 7		0.250	5
NA	13	S 201-B 13 NA	2CDS 251 103 R0135	53160 3		0.250	5
	16	S 201-B 16 NA	2CDS 251 103 R0165	53161 0		0.250	5
	20 ①	S 201-B 20 NA	2CDS 251 103 R0205	53162 7		0.250	5
	25	S 201-B 25 NA	2CDS 251 103 R0255	53163 4		0.250	5
	32 ②	S 201-B 32 NA	2CDS 251 103 R0325	53164 1		0.250	5
	40 ③	S 201-B 40 NA	2CDS 251 103 R0405	53165 8		0.250	5
	50	S 201-B 50 NA	2CDS 251 103 R0505	53615 8		0.250	5
	63	S 201-B 63 NA	2CDS 251 103 R0635	53614 1		0.250	5
U_{Bmax} 253 V ~ 72 V ...							
3	6	S 203-B 6 NA	2CDS 253 103 R0065	53228 0		0.500	1
+	10	S 203-B 10 NA	2CDS 253 103 R0105	53229 7		0.500	1
NA	13	S 203-B 13 NA	2CDS 253 103 R0135	53230 3		0.500	1
	16	S 203-B 16 NA	2CDS 253 103 R0165	53231 0		0.500	1
	20 ①	S 203-B 20 NA	2CDS 253 103 R0205	53232 7		0.500	1
	25	S 203-B 25 NA	2CDS 253 103 R0255	53233 4		0.500	1
	32 ②	S 203-B 32 NA	2CDS 253 103 R0325	53234 1		0.500	1
	40 ③	S 203-B 40 NA	2CDS 253 103 R0405	53235 8		0.500	1
	50	S 203-B 50 NA	2CDS 253 103 R0505	53616 5		0.580	1
	63	S 203-B 63 NA	2CDS 253 103 R0635	53617 2		0.580	1
U_{Bmax} 440 V ~							

① suitable for flow-type heaters 12 kW
② suitable for flow-type heaters 18 kW

③ suitable for flow-type heaters 21, 24 and 27 kW

2

C

2



2CSC400408F0201



2CSC400409F0201



2CSC400412F0201



S 200 C characteristic

Function: protection and control of the circuits against overloads and short-circuits; protection for resistive and inductive loads with low inrush current.

Applications: residential, commercial and industrial.

Standard: IEC/EN 60898, IEC/EN 60947-2

I_{cn}=6 kA

Number of poles	Rated current In A	Order details Type code	Order code	Bbn	Price 1 piece	Price group	Weight 1 piece kg	Pack unit pc.
				4016779				
1	0.5	S 201-C 0.5	2CDS 251 001 R0984	52329 5			0.125	10
	1	S 201-C 1	2CDS 251 001 R0014	52331 8			0.125	10
	1.6	S 201-C 1.6	2CDS 251 001 R0974	52330 1			0.125	10
	2	S 201-C 2	2CDS 251 001 R0024	52332 5			0.125	10
	3	S 201-C 3	2CDS 251 001 R0034	52333 2			0.125	10
	4	S 201-C 4	2CDS 251 001 R0044	52334 9			0.125	10
	6	S 201-C 6	2CDS 251 001 R0064	46400 0			0.125	10
	8	S 201-C 8	2CDS 251 001 R0084	46410 9			0.125	10
	10	S 201-C 10	2CDS 251 001 R0104	46420 8			0.125	10
	13	S 201-C 13	2CDS 251 001 R0134	46430 7			0.125	10
	16	S 201-C 16	2CDS 251 001 R0164	46440 6			0.125	10
	20 ①	S 201-C 20	2CDS 251 001 R0204	46450 5			0.125	10
	25	S 201-C 25	2CDS 251 001 R0254	46460 4			0.125	10
	32 ②	S 201-C 32	2CDS 251 001 R0324	46470 3			0.125	10
	40 ③	S 201-C 40	2CDS 251 001 R0404	46480 2			0.125	10
	50	S 201-C 50	2CDS 251 001 R0504	55100 7			0.125	10
63	S 201-C 63	2CDS 251 001 R0634	55101 4			0.125	10	
2	0.5	S 202-C 0.5	2CDS 252 001 R0984	52335 6			0.250	5
	1	S 202-C 1	2CDS 252 001 R0014	52336 3			0.250	5
	1.6	S 202-C 1.6	2CDS 252 001 R0974	52337 0			0.250	5
	2	S 202-C 2	2CDS 252 001 R0024	52338 7			0.250	5
	3	S 202-C 3	2CDS 252 001 R0034	52339 4			0.250	5
	4	S 202-C 4	2CDS 252 001 R0044	52340 0			0.250	5
	6	S 202-C 6	2CDS 252 001 R0064	46550 2			0.250	5
	8	S 202-C 8	2CDS 252 001 R0084	46560 1			0.250	5
	10	S 202-C 10	2CDS 252 001 R0104	46570 0			0.250	5
	13	S 202-C 13	2CDS 252 001 R0134	46580 9			0.250	5
	16	S 202-C 16	2CDS 252 001 R0164	46590 8			0.250	5
	20	S 202-C 20	2CDS 252 001 R0204	46600 4			0.250	5
	25	S 202-C 25	2CDS 252 001 R0254	46610 3			0.250	5
	32	S 202-C 32	2CDS 252 001 R0324	46620 2			0.250	5
	40	S 202-C 40	2CDS 252 001 R0404	46630 1			0.250	5
	50	S 202-C 50	2CDS 252 001 R0504	55104 5			0.250	5
④ 63	S 202-C 63	2CDS 252 001 R0634	55105 2			0.250	5	
3	0.5	S 203-C 0.5	2CDS 253 001 R0984	52341 7			0.375	1
	1	S 203-C 1	2CDS 253 001 R0014	52342 4			0.375	1
	1.6	S 203-C 1.6	2CDS 253 001 R0974	52343 1			0.375	1
	2	S 203-C 2	2CDS 253 001 R0024	52344 8			0.375	1
	3	S 203-C 3	2CDS 253 001 R0034	52345 5			0.375	1
	4	S 203-C 4	2CDS 253 001 R0044	52346 2			0.375	1
	6	S 203-C 6	2CDS 253 001 R0064	46750 6			0.375	1
	8	S 203-C 8	2CDS 253 001 R0084	46760 5			0.375	1
	10	S 203-C 10	2CDS 253 001 R0104	46780 3			0.375	1
	13	S 203-C 13	2CDS 253 001 R0134	46790 2			0.375	1
	16	S 203-C 16	2CDS 253 001 R0164	46800 8			0.375	1
	20 ①	S 203-C 20	2CDS 253 001 R0204	46810 7			0.375	1
	25	S 203-C 25	2CDS 253 001 R0254	46820 6			0.375	1
	32 ②	S 203-C 32	2CDS 253 001 R0324	46830 5			0.375	1
	40 ③	S 203-C 40	2CDS 253 001 R0404	46840 4			0.375	1
	50	S 203-C 50	2CDS 253 001 R0504	55106 9			0.375	1
④ 63	S 203-C 63	2CDS 253 001 R0634	55107 6			0.375	1	

U_{Bmax}
253 V ~
72 V ∴

U_{Bmax}
440 V ~
125 V ∴

U_{Bmax}
440 V ~

6000

2

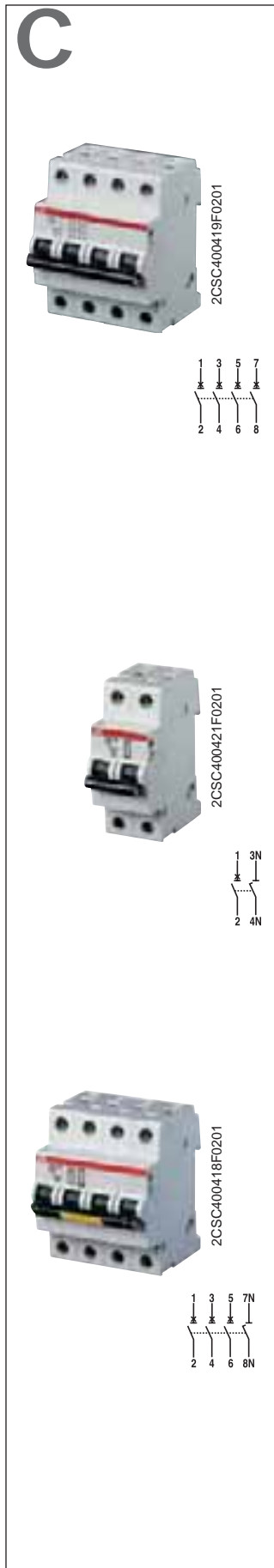

Number of poles	Rated current	Type code	Order code	EAN	Weight 1 piece	Pack unit
4	0.5	S 204-C 0.5	2CDS 254 001 R0984	52911 2	0.500	1
	1	S 204-C 1	2CDS 254 001 R0014	52912 9	0.500	1
	1.6	S 204-C 1.6	2CDS 254 001 R0974	52913 6	0.500	1
	2	S 204-C 2	2CDS 254 001 R0024	52914 3	0.500	1
	3	S 204-C 3	2CDS 254 001 R0034	52915 0	0.500	1
	4	S 204-C 4	2CDS 254 001 R0044	52916 7	0.500	1
	6	S 204-C 6	2CDS 254 001 R0064	52917 4	0.500	1
	8	S 204-C 8	2CDS 254 001 R0084	52918 1	0.500	1
	10	S 204-C 10	2CDS 254 001 R0104	52919 8	0.500	1
	13	S 204-C 13	2CDS 254 001 R0134	52920 4	0.500	1
	16	S 204-C 16	2CDS 254 001 R0164	52921 1	0.500	1
	20	S 204-C 20	2CDS 254 001 R0204	52922 8	0.500	1
	25	S 204-C 25	2CDS 254 001 R0254	52923 5	0.500	1
	32	S 204-C 32	2CDS 254 001 R0324	52924 2	0.500	1
40	S 204-C 40	2CDS 254 001 R0404	52925 9	0.500	1	
50	S 204-C 50	2CDS 254 001 R0504	55110 6	0.500	1	
63	S 204-C 63	2CDS 254 001 R0634	55111 3	0.500	1	

U_{Bmax}
440 V ~
125 V ∴

- ① suitable for flow-type heaters 12 kW
- ② suitable for flow-type heaters 18 kW
- ③ suitable for flow-type heaters 21, 24 and 27 kW
- ④ U_{Bmax} 125 V ∴ with 2 poles connected in series

With disconnecting neutral NA

Number of poles	Rated current	Order details	Bbn 4016779	Price 1 piece	Price group	Weight 1 piece	Pack unit
	In A	Type code	Order code	EAN		kg	pc.
1 + NA	0.5	S 201-C 0.5 NA	2CDS 251 103 R0984	53166 5		0.250	5
	1	S 201-C 1 NA	2CDS 251 103 R0014	53167 2		0.250	5
	1.6	S 201-C 1.6 NA	2CDS 251 103 R0974	53168 9		0.250	5
	2	S 201-C 2 NA	2CDS 251 103 R0024	53169 6		0.250	5
	3	S 201-C 3 NA	2CDS 251 103 R0034	53170 2		0.250	5
	4	S 201-C 4 NA	2CDS 251 103 R0044	53172 6		0.250	5
	6	S 201-C 6 NA	2CDS 251 103 R0064	53173 3		0.250	5
	8	S 201-C 8 NA	2CDS 251 103 R0084	53174 0		0.250	5
	10	S 201-C 10 NA	2CDS 251 103 R0104	53175 7		0.250	5
	13	S 201-C 13 NA	2CDS 251 103 R0134	53176 4		0.250	5
	16	S 201-C 16 NA	2CDS 251 103 R0164	53177 1		0.250	5
	20 ①	S 201-C 20 NA	2CDS 251 103 R0204	53178 8		0.250	5
	25	S 201-C 25 NA	2CDS 251 103 R0254	53179 5		0.250	5
	32 ②	S 201-C 32 NA	2CDS 251 103 R0324	53180 1		0.250	5
40 ③	S 201-C 40 NA	2CDS 251 103 R0404	53181 8		0.250	5	
50	S 201-C 50 NA	2CDS 251 103 R0504	55102 1		0.290	5	
63	S 201-C 63 NA	2CDS 251 103 R0634	55103 8		0.290	5	
3 + NA	0.5	S 203-C 0.5 NA	2CDS 253 103 R0984	53236 5		0.500	1
	1	S 203-C 1 NA	2CDS 253 103 R0014	53237 2		0.500	1
	1.6	S 203-C 1.6 NA	2CDS 253 103 R0974	53238 9		0.500	1
	2	S 203-C 2 NA	2CDS 253 103 R0024	53240 2		0.500	1
	3	S 203-C 3 NA	2CDS 253 103 R0034	53241 9		0.500	1
	4	S 203-C 4 NA	2CDS 253 103 R0044	53242 6		0.500	1
	6	S 203-C 6 NA	2CDS 253 103 R0064	53243 3		0.500	1
	8	S 203-C 8 NA	2CDS 253 103 R0084	53244 0		0.500	1
	10	S 203-C 10 NA	2CDS 253 103 R0104	53245 7		0.500	1
	13	S 203-C 13 NA	2CDS 253 103 R0134	53246 4		0.500	1
	16	S 203-C 16 NA	2CDS 253 103 R0164	53247 1		0.500	1
	20 ①	S 203-C 20 NA	2CDS 253 103 R0204	53248 8		0.500	1
	25	S 203-C 25 NA	2CDS 253 103 R0254	53249 5		0.500	1
	32 ②	S 203-C 32 NA	2CDS 253 103 R0324	53250 1		0.500	1
40 ③	S 203-C 40 NA	2CDS 253 103 R0404	53251 8		0.500	1	
50	S 203-C 50 NA	2CDS 253 103 R0504	55108 3		0.580	1	
63	S 203-C 63 NA	2CDS 253 103 R0634	55109 0		0.580	1	

U_{Bmax}
253 V ~
72 V ∴

U_{Bmax}
440 V ~

- ① suitable for flow-type heaters 12 kW
- ② suitable for flow-type heaters 18 kW
- ③ suitable for flow-type heaters 21, 24 and 27 kW

D

2



2CSC400408F0201



2CSC400409F0201



2CSC400412F0201



S 200 D characteristic

Function: protection and control of the circuits against overloads and short-circuits; protection for circuits which supply loads with high inrush current at the circuit closing (LV/LV transformers, breakdown lamps).

Applications: residential, commercial and industrial.

Standard: IEC/EN 60898, IEC/EN 60947-2

I_{cn}=6 kA

Number of poles	Rated current	Order details	Bbn 4016779	Price 1 piece	Price group	Weight 1 piece	Pack unit
In A	Type code	Order code	EAN			kg	pc.
1	0.5	S 201-D 0.5	2CDS 251 001 R0981	52993 8		0.125	10
	1	S 201-D 1	2CDS 251 001 R0011	52994 5		0.125	10
	1.6	S 201-D 1.6	2CDS 251 001 R0971	52995 2		0.125	10
	2	S 201-D 2	2CDS 251 001 R0021	52996 9		0.125	10
	3	S 201-D 3	2CDS 251 001 R0031	52997 6		0.125	10
	4	S 201-D 4	2CDS 251 001 R0041	52998 3		0.125	10
	6	S 201-D 6	2CDS 251 001 R0061	52999 0		0.125	10
	8	S 201-D 8	2CDS 251 001 R0081	53000 2		0.125	10
	10	S 201-D 10	2CDS 251 001 R0101	53001 9		0.125	10
	13	S 201-D 13	2CDS 251 001 R0131	53002 6		0.125	10
	16	S 201-D 16	2CDS 251 001 R0161	53003 3		0.125	10
	20 ①	S 201-D 20	2CDS 251 001 R0201	53004 0		0.125	10
	25	S 201-D 25	2CDS 251 001 R0251	53005 7		0.125	10
	32 ②	S 201-D 32	2CDS 251 001 R0321	53006 4		0.125	10
	40 ③	S 201-D 40	2CDS 251 001 R0401	53007 1		0.125	10
	50	S 201-D 50	2CDS 251 001 R0501	55199 1		0.125	10
63	S 201-D 63	2CDS 251 001 R0631	55200 4		0.125	10	
U_{Bmax} 253 V ~ 72 V ...							
2	0.5	S 202-D 0.5	2CDS 252 001 R0981	53048 4		0.250	5
	1	S 202-D 1	2CDS 252 001 R0011	53049 1		0.250	5
	1.6	S 202-D 1.6	2CDS 252 001 R0971	53050 7		0.250	5
	2	S 202-D 2	2CDS 252 001 R0021	53051 4		0.250	5
	3	S 202-D 3	2CDS 252 001 R0031	53052 1		0.250	5
	4	S 202-D 4	2CDS 252 001 R0041	53053 8		0.250	5
	6	S 202-D 6	2CDS 252 001 R0061	53054 5		0.250	5
	8	S 202-D 8	2CDS 252 001 R0081	53055 2		0.250	5
	10	S 202-D 10	2CDS 252 001 R0101	53058 3		0.250	5
	13	S 202-D 13	2CDS 252 001 R0131	53060 6		0.250	5
	16	S 202-D 16	2CDS 252 001 R0161	53061 3		0.250	5
	20	S 202-D 20	2CDS 252 001 R0201	53063 7		0.250	5
	25	S 202-D 25	2CDS 252 001 R0251	53064 4		0.250	5
	32	S 202-D 32	2CDS 252 001 R0321	53065 1		0.250	5
	40	S 202-D 40	2CDS 252 001 R0401	53066 8		0.250	5
	50	S 202-D 50	2CDS 252 001 R0501	55203 5		0.250	5
63	S 202-D 63	2CDS 252 001 R0631	55204 2		0.250	5	
U_{Bmax} 440 V ~ 125 V ... ④							
3	0.5	S 203-D 0.5	2CDS 253 001 R0981	53081 1		0.375	1
	1	S 203-D 1	2CDS 253 001 R0011	53082 8		0.375	1
	1.6	S 203-D 1.6	2CDS 253 001 R0971	53083 5		0.375	1
	2	S 203-D 2	2CDS 253 001 R0021	53084 2		0.375	1
	3	S 203-D 3	2CDS 253 001 R0031	53085 9		0.375	1
	4	S 203-D 4	2CDS 253 001 R0041	53086 6		0.375	1
	6	S 203-D 6	2CDS 253 001 R0061	53088 0		0.375	1
	8	S 203-D 8	2CDS 253 001 R0081	53089 7		0.375	1
	10	S 203-D 10	2CDS 253 001 R0101	53090 3		0.375	1
	13	S 203-D 13	2CDS 253 001 R0131	53091 0		0.375	1
	16	S 203-D 16	2CDS 253 001 R0161	53092 7		0.375	1
	20 ①	S 203-D 20	2CDS 253 001 R0201	53093 4		0.375	1
	25	S 203-D 25	2CDS 253 001 R0251	53094 1		0.375	1
	32 ②	S 203-D 32	2CDS 253 001 R0321	53095 8		0.375	1
	40 ③	S 203-D 40	2CDS 253 001 R0401	53096 5		0.375	1
	50	S 203-D 50	2CDS 253 001 R0501	55205 9		0.375	1
63	S 203-D 63	2CDS 253 001 R0631	55206 6		0.375	1	
U_{Bmax} 440 V ~							

6000

D



2CSC400419F0201



2CSC400421F0201



2CSC400418F0201



4	0.5	S 204-D	0.5	2CDS 254 001 R0981	53112 2	0.500	1
	1	S 204-D	1	2CDS 254 001 R0011	53113 9	0.500	1
	1.6	S 204-D	1.6	2CDS 254 001 R0971	53114 6	0.500	1
	2	S 204-D	2	2CDS 254 001 R0021	53115 3	0.500	1
	3	S 204-D	3	2CDS 254 001 R0031	53116 0	0.500	1
	4	S 204-D	4	2CDS 254 001 R0041	53117 7	0.500	1
	6	S 204-D	6	2CDS 254 001 R0061	53118 4	0.500	1
	8	S 204-D	8	2CDS 254 001 R0081	53119 1	0.500	1
	10	S 204-D	10	2CDS 254 001 R0101	53120 7	0.500	1
	13	S 204-D	13	2CDS 254 001 R0131	53121 4	0.500	1
	16	S 204-D	16	2CDS 254 001 R0161	53122 1	0.500	1
	20	S 204-D	20	2CDS 254 001 R0201	53123 8	0.500	1
	25	S 204-D	25	2CDS 254 001 R0251	53129 0	0.500	1
	32	S 204-D	32	2CDS 254 001 R0321	53130 6	0.500	1
	40	S 204-D	40	2CDS 254 001 R0401	53131 3	0.500	1
	50	S 204-D	50	2CDS 254 001 R0501	55209 7	0.500	1
	63	S 204-D	63	2CDS 254 001 R0631	55210 3	0.500	1

U_{Bmax}
440 V ~
125 V ∴

- ① suitable for flow-type heaters 12 kW
② suitable for flow-type heaters 18 kW

- ③ suitable for flow-type heaters 21, 24 and 27 kW
④ U_{Bmax} 125 V ∴ with 2 poles connected in series

With disconnecting neutral NA

Number of poles	Rated current	Order details		Bbn 4016779	Price 1 piece	Price group	Weight 1 piece	Pack unit
	In A	Type code	Order code	EAN			kg	pc.
1	0.5	S 201-D 0.5 NA	2CDS 251 103 R0981	53197 9			0.250	5
+	1	S 201-D 1 NA	2CDS 251 103 R0011	53199 3			0.250	5
NA	1.6	S 201-D 1.6 NA	2CDS 251 103 R0971	53198 6			0.250	5
	2	S 201-D 2 NA	2CDS 251 103 R0021	53200 6			0.250	5
	3	S 201-D 3 NA	2CDS 251 103 R0031	53201 3			0.250	5
	4	S 201-D 4 NA	2CDS 251 103 R0041	53202 0			0.250	5
	6	S 201-D 6 NA	2CDS 251 103 R0061	53203 7			0.250	5
	8	S 201-D 8 NA	2CDS 251 103 R0081	53204 4			0.250	5
	10	S 201-D 10 NA	2CDS 251 103 R0101	53205 1			0.250	5
	13	S 201-D 13 NA	2CDS 251 103 R0131	53206 8			0.250	5
	16	S 201-D 16 NA	2CDS 251 103 R0161	53209 9			0.250	5
	20 ①	S 201-D 20 NA	2CDS 251 103 R0201	53210 5			0.250	5
	25	S 201-D 25 NA	2CDS 251 103 R0251	53211 2			0.250	5
	32 ②	S 201-D 32 NA	2CDS 251 103 R0321	53212 9			0.250	5
	40 ③	S 201-D 40 NA	2CDS 251 103 R0401	53213 6			0.250	5
	50	S 201-D 50 NA	2CDS 251 103 R0501	55201 1			0.290	5
	63	S 201-D 63 NA	2CDS 251 103 R0631	55202 8			0.290	5

3	0.5	S 203-D 0.5 NA	2CDS 253 103 R0981	53276 1			0.500	2
+	1	S 203-D 1 NA	2CDS 253 103 R0011	53278 5			0.500	2
NA	1.6	S 203-D 1.6 NA	2CDS 253 103 R0971	53277 8			0.500	2
	2	S 203-D 2 NA	2CDS 253 103 R0021	53279 2			0.500	2
	3	S 203-D 3 NA	2CDS 253 103 R0031	53280 8			0.500	2
	4	S 203-D 4 NA	2CDS 253 103 R0041	53281 5			0.500	2
	6	S 203-D 6 NA	2CDS 253 103 R0061	53282 2			0.500	2
	8	S 203-D 8 NA	2CDS 253 103 R0081	53283 9			0.500	2
	10	S 203-D 10 NA	2CDS 253 103 R0101	53284 6			0.500	2
	13	S 203-D 13 NA	2CDS 253 103 R0131	53286 0			0.500	2
	16	S 203-D 16 NA	2CDS 253 103 R0161	53287 7			0.500	2
	20 ①	S 203-D 20 NA	2CDS 253 103 R0201	53288 4			0.500	2
	25	S 203-D 25 NA	2CDS 253 103 R0251	53289 1			0.500	2
	32 ②	S 203-D 32 NA	2CDS 253 103 R0321	53290 7			0.500	2
	40 ③	S 203-D 40 NA	2CDS 253 103 R0401	53291 4			0.500	2
	50	S 203-D 50 NA	2CDS 253 103 R0501	55207 3			0.580	2
	63	S 203-D 63 NA	2CDS 253 103 R0631	55208 0			0.580	2

U_{Bmax}
253 V ~
72 V ∴

- ① suitable for flow-type heaters 12 kW
② suitable for flow-type heaters 18 kW

- ③ suitable for flow-type heaters 21, 24 and 27 kW

10000

K

2



S 200 K (power) characteristic

Function: protection and control of the circuits like motors, transformer and auxiliary circuits, against overloads and short-circuits.

Advantages: no nuisance tripping in the case of functional peak currents up to 8xI_n, depending on the series; through its highly sensitive thermostatic bimetal trip, the K-type characteristic offers protection to damageable elements in the overcurrent range; it also provides the best protection to cables and lines.

Applications: commercial and industrial.

Standard: IEC/EN 60947-2, VDE 0660 Part 101

I_{cu}=6 kA (acc. to VDE 0660 Part 101)

Number of poles	Rated current	Order details	Bbn 4016779	Price 1 piece	Price group	Weight 1 piece	Pack unit
In A	Type code	Order code	EAN	kg	pc.		
1	0.5	S 201-K 0.5	2CDS 251 001 R0157	50719 6		0.125	10
	1	S 201-K 1	2CDS 251 001 R0217	50720 2		0.125	10
	1.6	S 201-K 1.6	2CDS 251 001 R0257	50721 9		0.125	10
	2	S 201-K 2	2CDS 251 001 R0277	50722 6		0.125	10
	3	S 201-K 3	2CDS 251 001 R0317	50723 3		0.125	10
	4	S 201-K 4	2CDS 251 001 R0337	50724 0		0.125	10
	6	S 201-K 6	2CDS 251 001 R0377	50725 7		0.125	10
	8	S 201-K 8	2CDS 251 001 R0407	50726 4		0.125	10
	10	S 201-K 10	2CDS 251 001 R0427	49611 7		0.125	10
	13	S 201-K 13	2CDS 251 001 R0447	50727 1		0.125	10
	16	S 201-K 16	2CDS 251 001 R0467	49612 4		0.125	10
	20	S 201-K 20	2CDS 251 001 R0487	50728 8		0.125	10
	25	S 201-K 25	2CDS 251 001 R0517	50729 5		0.125	10
	32	S 201-K 32	2CDS 251 001 R0537	49613 1		0.125	10
	40	S 201-K 40	2CDS 251 001 R0557	50730 1		0.125	10
	50	S 201-K 50	2CDS 251 001 R0577	55112 0		0.125	10
	63	S 201-K 63	2CDS 251 001 R0607	55113 7		0.125	10
U _{Bmax} 253 V ~ 72 V ...							
2	0.5	S 202-K 0.5	2CDS 252 001 R0157	50731 8		0.250	5
	1	S 202-K 1	2CDS 252 001 R0217	50732 5		0.250	5
	1.6	S 202-K 1.6	2CDS 252 001 R0257	50733 2		0.250	5
	2	S 202-K 2	2CDS 252 001 R0277	50734 9		0.250	5
	3	S 202-K 3	2CDS 252 001 R0317	50735 6		0.250	5
	4	S 202-K 4	2CDS 252 001 R0337	50736 3		0.250	5
	6	S 202-K 6	2CDS 252 001 R0377	50737 0		0.250	5
	8	S 202-K 8	2CDS 252 001 R0407	50738 7		0.250	5
	10	S 202-K 10	2CDS 252 001 R0427	50739 4		0.250	5
	13	S 202-K 13	2CDS 252 001 R0447	50740 0		0.250	5
	16	S 202-K 16	2CDS 252 001 R0467	50741 7		0.250	5
	20	S 202-K 20	2CDS 252 001 R0487	50742 4		0.250	5
	25	S 202-K 25	2CDS 252 001 R0517	50743 1		0.250	5
	32	S 202-K 32	2CDS 252 001 R0537	50744 8		0.250	5
	40	S 202-K 40	2CDS 252 001 R0557	50745 5		0.250	5
	50	S 202-K 50	2CDS 252 001 R0577	55116 8		0.250	5
	63	S 202-K 63	2CDS 252 001 R0607	55117 5		0.250	5
U _{Bmax} 440 V ~ 125 V ...							
3	0.5	S 203-K 0.5	2CDS 253 001 R0157	50746 2		0.375	1
	1	S 203-K 1	2CDS 253 001 R0217	50747 9		0.375	1
	1.6	S 203-K 1.6	2CDS 253 001 R0257	50748 6		0.375	1
	2	S 203-K 2	2CDS 253 001 R0277	50749 3		0.375	1
	3	S 203-K 3	2CDS 253 001 R0317	50750 9		0.375	1
	4	S 203-K 4	2CDS 253 001 R0337	50751 6		0.375	1
	6	S 203-K 6	2CDS 253 001 R0377	50752 3		0.375	1
	8	S 203-K 8	2CDS 253 001 R0407	50753 0		0.375	1
	10	S 203-K 10	2CDS 253 001 R0427	49614 8		0.375	1
	13	S 203-K 13	2CDS 253 001 R0447	50754 7		0.375	1
	16	S 203-K 16	2CDS 253 001 R0467	49615 5		0.375	1
	20	S 203-K 20	2CDS 253 001 R0487	50755 4		0.375	1
	25	S 203-K 25	2CDS 253 001 R0517	50756 1		0.375	1
	32	S 203-K 32	2CDS 253 001 R0537	49616 2		0.375	1
	40	S 203-K 40	2CDS 253 001 R0557	50757 8		0.375	1
	50	S 203-K 50	2CDS 253 001 R0577	55118 2		0.375	1
	63	S 203-K 63	2CDS 253 001 R0607	55119 9		0.375	1
U _{Bmax} 440 V ~							

6000

2

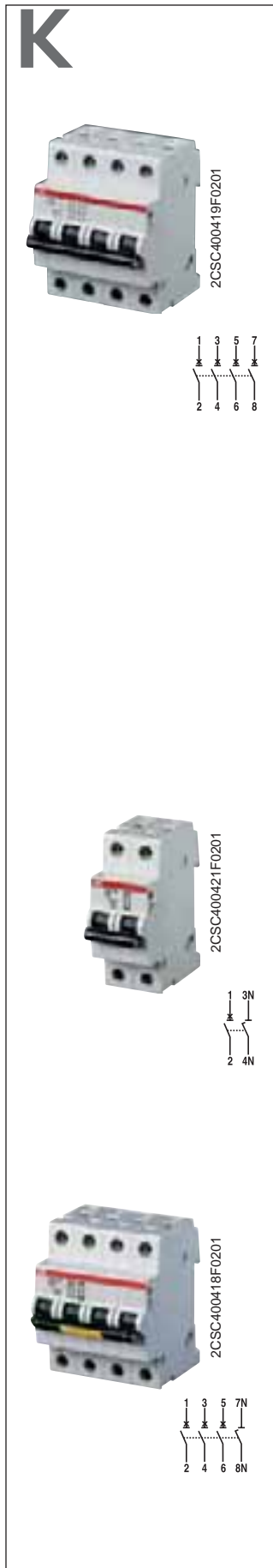

4	0.5	S 204-K 0.5	2CDS 254 001 R0157	52926 6	0.500	1
	1	S 204-K 1	2CDS 254 001 R0217	52927 3	0.500	1
	1.6	S 204-K 1.6	2CDS 254 001 R0257	52928 0	0.500	1
	2	S 204-K 2	2CDS 254 001 R0277	52929 7	0.500	1
	3	S 204-K 3	2CDS 254 001 R0317	52930 3	0.500	1
	4	S 204-K 4	2CDS 254 001 R0337	52931 0	0.500	1
	6	S 204-K 6	2CDS 254 001 R0377	52932 7	0.500	1
	8	S 204-K 8	2CDS 254 001 R0407	52933 4	0.500	1
	10	S 204-K 10	2CDS 254 001 R0427	52934 1	0.500	1
	13	S 204-K 13	2CDS 254 001 R0447	52935 8	0.500	1
	16	S 204-K 16	2CDS 254 001 R0467	52936 5	0.500	1
	20	S 204-K 20	2CDS 254 001 R0487	52937 2	0.500	1
	25	S 204-K 25	2CDS 254 001 R0517	52938 9	0.500	1
	32	S 204-K 32	2CDS 254 001 R0537	52939 6	0.500	1
	40	S 204-K 40	2CDS 254 001 R0557	52940 2	0.500	1
	U_{Bmax} 440 V ~	50	S 204-K 50	2CDS 254 001 R0577	55122 9	0.500
63		S 204-K 63	2CDS 254 001 R0607	55123 6	0.500	1
60 V ...						

① U_{Bmax} 125 V ... with 2 poles connected in series

With disconnecting neutral NA

Number of poles	Rated current	Order details		Bbn 4016779	Price 1 piece	Price group	Weight 1 piece	Pack unit
		In A	Type code					
1	0.5	S 201-K 0.5 NA	2CDS 251 103 R0157	53182 5	0.250	5		
	1	S 201-K 1 NA	2CDS 251 103 R0217	53183 2	0.250	5		
	NA	1.6	S 201-K 1.6 NA	2CDS 251 103 R0257	53184 9	0.250	5	
		2	S 201-K 2 NA	2CDS 251 103 R0277	53185 6	0.250	5	
		3	S 201-K 3 NA	2CDS 251 103 R0317	53186 3	0.250	5	
		4	S 201-K 4 NA	2CDS 251 103 R0337	53187 0	0.250	5	
		6	S 201-K 6 NA	2CDS 251 103 R0377	53188 7	0.250	5	
		8	S 201-K 8 NA	2CDS 251 103 R0407	53189 4	0.250	5	
		10	S 201-K 10 NA	2CDS 251 103 R0427	53190 0	0.250	5	
		13	S 201-K 13 NA	2CDS 251 103 R0447	53191 7	0.250	5	
		16	S 201-K 16 NA	2CDS 251 103 R0467	53192 4	0.250	5	
		20	S 201-K 20 NA	2CDS 251 103 R0487	53193 1	0.250	5	
	25	S 201-K 25 NA	2CDS 251 103 R0517	53194 8	0.250	5		
	32	S 201-K 32 NA	2CDS 251 103 R0537	53195 5	0.250	5		
	40	S 201-K 40 NA	2CDS 251 103 R0557	53196 2	0.250	5		
	50	S 201-K 50 NA	2CDS 251 103 R0577	55114 4	0.250	5		
63	S 201-K 63 NA	2CDS 251 103 R0607	55115 1	0.250	5			
U_{Bmax} 253 V ~ 72 V ...								
3	0.5	S 203-K 0.5 NA	2CDS 253 103 R0157	53261 7	0.500	1		
	1	S 203-K 1 NA	2CDS 253 103 R0217	53262 4	0.500	1		
	NA	1.6	S 203-K 1.6 NA	2CDS 253 103 R0257	53263 1	0.500	1	
		2	S 203-K 2 NA	2CDS 253 103 R0277	53264 8	0.500	1	
		3	S 203-K 3 NA	2CDS 253 103 R0317	53265 5	0.500	1	
		4	S 203-K 4 NA	2CDS 253 103 R0337	53266 2	0.500	1	
		6	S 203-K 6 NA	2CDS 253 103 R0377	53267 9	0.500	1	
		8	S 203-K 8 NA	2CDS 253 103 R0407	53268 6	0.500	1	
		10	S 203-K 10 NA	2CDS 253 103 R0427	53269 3	0.500	1	
		13	S 203-K 13 NA	2CDS 253 103 R0447	53270 9	0.500	1	
		16	S 203-K 16 NA	2CDS 253 103 R0467	53271 6	0.500	1	
		20	S 203-K 20 NA	2CDS 253 103 R0487	53272 3	0.500	1	
	25	S 203-K 25 NA	2CDS 253 103 R0517	53273 0	0.500	1		
	32	S 203-K 32 NA	2CDS 253 103 R0537	53274 7	0.500	1		
	40	S 203-K 40 NA	2CDS 253 103 R0557	53275 4	0.500	1		
	50	S 203-K 50 NA	2CDS 253 103 R0577	55120 5	0.500	1		
63	S 203-K 63 NA	2CDS 253 103 R0607	55121 2	0.500	1			
U_{Bmax} 440 V ~								

Z

2



2CSC400423F0201



2CSC400416F0201



2CSC400417F0201



S 200 Z characteristic

Function: protection and control of the electronic circuits against weak and long duration overloads and short-circuits.

Applications: commercial and industrial.

Standard: IEC/EN 60947-2, VDE 0660 Part 101

I_{cu}=6 kA (acc. to VDE 0660 Part 101)

Number of poles	Rated current	Order details	Bbn 4016779	Price 1 piece	Price group	Weight 1 piece	Pack unit
In A	Type code	Order code	EAN			kg	pc.
1	0.5	S 201-Z 0.5	2CDS 251 001 R0158	53030 9		0.125	10
	1	S 201-Z 1	2CDS 251 001 R0218	53033 0		0.125	10
	1.6	S 201-Z 1.6	2CDS 251 001 R0258	53034 7		0.125	10
	2	S 201-Z 2	2CDS 251 001 R0278	53035 4		0.125	10
	3	S 201-Z 3	2CDS 251 001 R0318	53036 1		0.125	10
	4	S 201-Z 4	2CDS 251 001 R0338	53037 8		0.125	10
	6	S 201-Z 6	2CDS 251 001 R0378	53040 8		0.125	10
	8	S 201-Z 8	2CDS 251 001 R0408	53041 5		0.125	10
	10	S 201-Z 10	2CDS 251 001 R0428	53042 2		0.125	10
	16	S 201-Z 16	2CDS 251 001 R0468	53043 9		0.125	10
	20	S 201-Z 20	2CDS 251 001 R0488	53044 6		0.125	10
	25	S 201-Z 25	2CDS 251 001 R0518	53045 3		0.125	10
	32	S 201-Z 32	2CDS 251 001 R0538	53046 0		0.125	10
	40	S 201-Z 40	2CDS 251 001 R0558	53047 7		0.125	10
50	S 201-Z 50	2CDS 251 001 R0578	55191 5		0.125	10	
63	S 201-Z 63	2CDS 251 001 R0608	55192 2		0.125	10	
U_{Bmax} 253 V ~ 72 V ...							
2	0.5	S 202-Z 0.5	2CDS 252 001 R0158	53068 2		0.250	5
	1	S 202-Z 1	2CDS 252 001 R0218	53067 5		0.250	5
	1.6	S 202-Z 1.6	2CDS 252 001 R0258	53069 9		0.250	5
	2	S 202-Z 2	2CDS 252 001 R0278	53070 5		0.250	5
	3	S 202-Z 3	2CDS 252 001 R0318	53071 2		0.250	5
	4	S 202-Z 4	2CDS 252 001 R0338	53072 9		0.250	5
	6	S 202-Z 6	2CDS 252 001 R0378	53073 6		0.250	5
	8	S 202-Z 8	2CDS 252 001 R0408	53074 3		0.250	5
	10	S 202-Z 10	2CDS 252 001 R0428	53075 0		0.250	5
	16	S 202-Z 16	2CDS 252 001 R0468	53076 7		0.250	5
	20	S 202-Z 20	2CDS 252 001 R0488	53077 4		0.250	5
	25	S 202-Z 25	2CDS 252 001 R0518	53078 1		0.250	5
	32	S 202-Z 32	2CDS 252 001 R0538	53079 8		0.250	5
	40	S 202-Z 40	2CDS 252 001 R0558	53080 4		0.250	5
50	S 202-Z 50	2CDS 252 001 R0578	55193 9		0.250	5	
63	S 202-Z 63	2CDS 252 001 R0608	55194 6		0.250	5	
U_{Bmax} 440 V ~ 125 V ...							
3	0.5	S 203-Z 0.5	2CDS 253 001 R0158	53097 2		0.375	1
	1	S 203-Z 1	2CDS 253 001 R0218	53098 9		0.375	1
	1.6	S 203-Z 1.6	2CDS 253 001 R0258	53099 6		0.375	1
	2	S 203-Z 2	2CDS 253 001 R0278	53100 9		0.375	1
	3	S 203-Z 3	2CDS 253 001 R0318	53101 6		0.375	1
	4	S 203-Z 4	2CDS 253 001 R0338	53102 3		0.375	1
	6	S 203-Z 6	2CDS 253 001 R0378	53103 0		0.375	1
	8	S 203-Z 8	2CDS 253 001 R0408	53104 7		0.375	1
	10	S 203-Z 10	2CDS 253 001 R0428	53105 4		0.375	1
	16	S 203-Z 16	2CDS 253 001 R0468	53106 1		0.375	1
	20	S 203-Z 20	2CDS 253 001 R0488	53107 8		0.375	1
	25	S 203-Z 25	2CDS 253 001 R0518	53108 5		0.375	1
	32	S 203-Z 32	2CDS 253 001 R0538	53109 2		0.375	1
	40	S 203-Z 40	2CDS 253 001 R0558	53110 8		0.375	1
50	S 203-Z 50	2CDS 253 001 R0578	55195 3		0.375	1	
63	S 203-Z 63	2CDS 253 001 R0608	55196 0		0.375	1	
U_{Bmax} 440 V ~							



4	0.5	S 204-Z 0.5	2CDS 254 001 R0158	53024 8	0.500	1
	1	S 204-Z 1	2CDS 254 001 R0218	53132 0	0.500	1
	1.6	S 204-Z 1.6	2CDS 254 001 R0258	53144 3	0.500	1
	2	S 204-Z 2	2CDS 254 001 R0278	53143 6	0.500	1
	3	S 204-Z 3	2CDS 254 001 R0318	53133 7	0.500	1
	4	S 204-Z 4	2CDS 254 001 R0338	53134 4	0.500	1
	6	S 204-Z 6	2CDS 254 001 R0378	53135 1	0.500	1
	8	S 204-Z 8	2CDS 254 001 R0408	53136 8	0.500	1
	10	S 204-Z 10	2CDS 254 001 R0428	53137 5	0.500	1
	16	S 204-Z 16	2CDS 254 001 R0468	53138 2	0.500	1
	20	S 204-Z 20	2CDS 254 001 R0488	53139 9	0.500	1
	25	S 204-Z 25	2CDS 254 001 R0518	53140 5	0.500	1
	32	S 204-Z 32	2CDS 254 001 R0538	53141 2	0.500	1
	40	S 204-Z 40	2CDS 254 001 R0558	53142 9	0.500	1
50	S 204-Z 50	2CDS 254 001 R0578	55197 7	0.500	1	
63	S 204-Z 63	2CDS 254 001 R0608	55198 4	0.500	1	

U_{Bmax} 440 V ~
125 V ...

① U_{Bmax} 125 V ... with 2 poles connected in series

With disconnecting neutral NA

Number of poles	Rated current	Order details	Bbn 4016779	Price 1 piece	Price group	Weight 1 piece	Pack unit
In A	Type code	Order code	EAN			kg	pc.
1 + NA	0.5	S 201-Z 0.5 NA	2CDS 251 103 R0158	53214 3		0.260	5
	1	S 201-Z 1 NA	2CDS 251 103 R0218	53215 0		0.260	5
	1.6	S 201-Z 1.6 NA	2CDS 251 103 R0258	53216 7		0.260	5
	2	S 201-Z 2 NA	2CDS 251 103 R0278	53217 4		0.260	5
	3	S 201-Z 3 NA	2CDS 251 103 R0318	53218 1		0.260	5
	4	S 201-Z 4 NA	2CDS 251 103 R0338	53219 8		0.260	5
	6	S 201-Z 6 NA	2CDS 251 103 R0378	53220 4		0.260	5
	8	S 201-Z 8 NA	2CDS 251 103 R0408	53221 1		0.260	5
	10	S 201-Z 10 NA	2CDS 251 103 R0428	53222 8		0.260	5
	16	S 201-Z 16 NA	2CDS 251 103 R0468	53223 5		0.260	5
	20	S 201-Z 20 NA	2CDS 251 103 R0488	53224 2		0.260	5
	25	S 201-Z 25 NA	2CDS 251 103 R0518	53225 9		0.260	5
	32	S 201-Z 32 NA	2CDS 251 103 R0538	53226 6		0.260	5
	40	S 201-Z 40 NA	2CDS 251 103 R0558	53227 3		0.260	5
50	S 201-Z 50 NA	2CDS 251 103 R0578	55212 7		0.320	5	
63	S 201-Z 63 NA	2CDS 251 103 R0608	55213 4		0.320	5	
U _{Bmax} 253 V ~ 72 V ...							
3 + NA	0.5	S 203-Z 0.5 NA	2CDS 253 103 R0158	53292 1		0.520	1
	1	S 203-Z 1 NA	2CDS 253 103 R0218	53293 8		0.520	1
	1.6	S 203-Z 1.6 NA	2CDS 253 103 R0258	53294 5		0.520	1
	2	S 203-Z 2 NA	2CDS 253 103 R0278	53295 2		0.520	1
	3	S 203-Z 3 NA	2CDS 253 103 R0318	53297 6		0.520	1
	4	S 203-Z 4 NA	2CDS 253 103 R0338	53298 3		0.520	1
	6	S 203-Z 6 NA	2CDS 253 103 R0378	53299 0		0.520	1
	8	S 203-Z 8 NA	2CDS 253 103 R0408	53300 3		0.520	1
	10	S 203-Z 10 NA	2CDS 253 103 R0428	53301 0		0.520	1
	16	S 203-Z 16 NA	2CDS 253 103 R0468	53302 7		0.520	1
	20	S 203-Z 20 NA	2CDS 253 103 R0488	53305 8		0.520	1
	25	S 203-Z 25 NA	2CDS 253 103 R0518	53306 5		0.520	1
	32	S 203-Z 32 NA	2CDS 253 103 R0538	53307 2		0.520	1
	40	S 203-Z 40 NA	2CDS 253 103 R0558	53308 9		0.520	1
50	S 203-Z 50 NA	2CDS 253 103 R0578	55214 1		0.640	1	
63	S 203-Z 63 NA	2CDS 253 103 R0608	55216 5		0.640	1	
U _{Bmax} 440 V ~							

B

2



2CSC400411F0201



2CSC400413F0201



2CSC400415F0201



2CSC400443F0201



S 200 M-B characteristic

Function: protection and control of the circuits against overloads and short-circuits; protection for people and big length cables in TN and IT systems.

Applications: residential, commercial and industrial.

Standard: IEC/EN 60898, IEC/EN 60947-2

I_{cn}=10 kA

Number of poles	Rated current	Order details	Bbn 4016779	Price 1 piece	Price group	Weight 1 piece	Pack unit
1	6	S 201 M-B 6	2CDS 271 001 R0065	54942 4		0.125	10
	10	S 201 M-B 10	2CDS 271 001 R0105	54943 1		0.125	10
	13	S 201 M-B 13	2CDS 271 001 R0135	54944 8		0.125	10
	16	S 201 M-B 16	2CDS 271 001 R0165	54945 5		0.125	10
	20 ①	S 201 M-B 20	2CDS 271 001 R0205	54946 2		0.125	10
	25	S 201 M-B 25	2CDS 271 001 R0255	54947 9		0.125	10
	32 ②	S 201 M-B 32	2CDS 271 001 R0325	54948 6		0.125	10
	40 ③	S 201 M-B 40	2CDS 271 001 R0405	54949 3		0.125	10
	50	S 201 M-B 50	2CDS 271 001 R0505	54381 1		0.125	10
	63	S 201 M-B 63	2CDS 271 001 R0635	54382 8		0.125	10
U _{Bmax} 253 V ~ 72 V ...							
2	6	S 202 M-B 6	2CDS 272 001 R0065	54958 5		0.250	5
	10	S 202 M-B 10	2CDS 272 001 R0105	54959 2		0.250	5
	13	S 202 M-B 13	2CDS 272 001 R0135	54960 8		0.250	5
	16	S 202 M-B 16	2CDS 272 001 R0165	54961 5		0.250	5
	20	S 202 M-B 20	2CDS 272 001 R0205	54962 2		0.250	5
	25	S 202 M-B 25	2CDS 272 001 R0255	54963 9		0.250	5
	32	S 202 M-B 32	2CDS 272 001 R0325	54964 6		0.250	5
	40	S 202 M-B 40	2CDS 272 001 R0405	54965 3		0.250	5
	50	S 202 M-B 50	2CDS 272 001 R0505	54385 9		0.250	5
	63	S 202 M-B 63	2CDS 272 001 R0635	54386 6		0.250	5
U _{Bmax} 440 V ~ 125 V ... ④							
3	6	S 203 M-B 6	2CDS 273 001 R0065	54966 0		0.375	1
	10	S 203 M-B 10	2CDS 273 001 R0105	54967 7		0.375	1
	13	S 203 M-B 13	2CDS 273 001 R0135	54968 4		0.375	1
	16	S 203 M-B 16	2CDS 273 001 R0165	54969 1		0.375	1
	20 ①	S 203 M-B 20	2CDS 273 001 R0205	54970 7		0.375	1
	25	S 203 M-B 25	2CDS 273 001 R0255	54971 4		0.375	1
	32 ②	S 203 M-B 32	2CDS 273 001 R0325	54972 1		0.375	1
	40 ③	S 203 M-B 40	2CDS 273 001 R0405	54973 8		0.375	1
	50	S 203 M-B 50	2CDS 273 001 R0505	54387 3		0.375	1
	63	S 203 M-B 63	2CDS 273 001 R0635	54388 0		0.375	1
U _{Bmax} 440 V ~							
4	6	S 204 M-B 6	2CDS 274 001 R0065	54982 0		0.500	1
	10	S 204 M-B 10	2CDS 274 001 R0105	54983 7		0.500	1
	13	S 204 M-B 13	2CDS 274 001 R0135	54984 4		0.500	1
	16	S 204 M-B 16	2CDS 274 001 R0165	54985 1		0.500	1
	20	S 204 M-B 20	2CDS 274 001 R0205	54986 8		0.500	1
	25	S 204 M-B 25	2CDS 274 001 R0255	54987 5		0.500	1
	32	S 204 M-B 32	2CDS 274 001 R0325	54988 2		0.500	1
	40	S 204 M-B 40	2CDS 274 001 R0405	54989 9		0.500	1
	50	S 204 M-B 50	2CDS 274 001 R0505	54391 0		0.500	1
	63	S 204 M-B 63	2CDS 274 001 R0635	54392 7		0.500	1
U _{Bmax} 440 V ~ 125 V ... ④							

① suitable for flow-type heaters 12 kW

② suitable for flow-type heaters 18 kW

③ suitable for flow-type heaters 21, 24 and 27 kW

④ U_{Bmax} 125 V ... with 2 poles connected in series

B

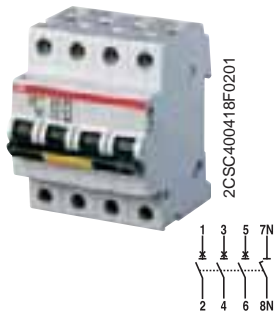
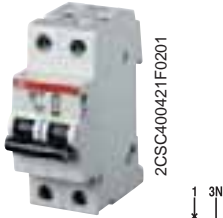

With disconnecting neutral NA

Number of poles	Rated current In A	Order details Type code	Order code	Bbn 4016779 EAN	Price 1 piece	Price group	Weight 1 piece kg	Pack unit pc.	
1 +	6	S 201 M-B 6 NA	2CDS 271 103 R0065	54950 9			0.250	5	
	10	S 201 M-B 10 NA	2CDS 271 103 R0105	54951 6			0.250	5	
	NA	13	S 201 M-B 13 NA	2CDS 271 103 R0135	54952 3			0.250	5
		16	S 201 M-B 16 NA	2CDS 271 103 R0165	54953 0			0.250	5
		20 ①	S 201 M-B 20 NA	2CDS 271 103 R0205	54954 7			0.250	5
		25	S 201 M-B 25 NA	2CDS 271 103 R0255	54955 4			0.250	5
	U _{Bmax} 253 V ~ 72 V ...	32 ②	S 201 M-B 32 NA	2CDS 271 103 R0325	54956 1			0.250	5
		40 ③	S 201 M-B 40 NA	2CDS 271 103 R0405	54957 8			0.250	5
		50	S 201 M-B 50 NA	2CDS 271 103 R0505	54383 5			0.250	5
		63	S 201 M-B 63 NA	2CDS 271 103 R0635	54384 2			0.250	5
3 +		6	S 203 M-B 6 NA	2CDS 273 103 R0065	54974 5			0.500	1
	10	S 203 M-B 10 NA	2CDS 273 103 R0105	54975 2			0.500	1	
	NA	13	S 203 M-B 13 NA	2CDS 273 103 R0135	54976 9			0.500	1
		16	S 203 M-B 16 NA	2CDS 273 103 R0165	54977 6			0.500	1
		20 ①	S 203 M-B 20 NA	2CDS 273 103 R0205	54978 3			0.500	1
		25	S 203 M-B 25 NA	2CDS 273 103 R0255	54979 0			0.500	1
	U _{Bmax} 440 V ~	32 ②	S 203 M-B 32 NA	2CDS 273 103 R0325	54980 6			0.500	1
		40 ③	S 203 M-B 40 NA	2CDS 273 103 R0405	54981 3			0.500	1
		50	S 203 M-B 50 NA	2CDS 273 103 R0505	54389 7			0.500	1
		63	S 203 M-B 63 NA	2CDS 273 103 R0635	54390 3			0.580	1

① suitable for flow-type heaters 12 kW
② suitable for flow-type heaters 18 kW

③ suitable for flow-type heaters 21, 24 and 27 kW

2

10000

C



2CSC400424F0201



2CSC400425F0201



2CSC400426F0201



S 200 M-C characteristic

Function: protection and control of the circuits against overloads and short-circuits; protection for resistive and inductive loads with low inrush current.

Applications: residential, commercial and industrial.

Standard: IEC/EN 60898, IEC/EN 60947-2

I_{cn}=10 kA

Number of poles	Rated current	Order details	Bbn 4016779	Price 1 piece	Price group	Weight 1 piece	Pack unit
In A	Type code	Order code	EAN			kg	pc.
1	0.5	S 201 M-C 0.5	2CDS 271 001 R0984	54990 5		0.125	10
	1	S 201 M-C 1	2CDS 271 001 R0014	54992 9		0.125	10
	1.6	S 201 M-C 1.6	2CDS 271 001 R0974	54991 2		0.125	10
	2	S 201 M-C 2	2CDS 271 001 R0024	54993 6		0.125	10
	3	S 201 M-C 3	2CDS 271 001 R0034	54994 3		0.125	10
	4	S 201 M-C 4	2CDS 271 001 R0044	54995 0		0.125	10
	6	S 201 M-C 6	2CDS 271 001 R0064	54996 7		0.125	10
	8	S 201 M-C 8	2CDS 271 001 R0084	54997 4		0.125	10
	10	S 201 M-C 10	2CDS 271 001 R0104	54998 1		0.125	10
	13	S 201 M-C 13	2CDS 271 001 R0134	54999 8		0.125	10
	16	S 201 M-C 16	2CDS 271 001 R0164	55000 0		0.125	10
	20 ①	S 201 M-C 20	2CDS 271 001 R0204	55001 7		0.125	10
	25	S 201 M-C 25	2CDS 271 001 R0254	55002 4		0.125	10
	32 ②	S 201 M-C 32	2CDS 271 001 R0324	55003 1		0.125	10
	40 ③	S 201 M-C 40	2CDS 271 001 R0404	55004 8		0.125	10
	50	S 201 M-C 50	2CDS 271 001 R0504	54393 4		0.125	10
63	S 201 M-C 63	2CDS 271 001 R0634	54394 1		0.125	10	
U_{Bmax} 253 V ~ 72 V ...							
2	0.5	S 202 M-C 0.5	2CDS 272 001 R0984	55020 8		0.250	5
	1	S 202 M-C 1	2CDS 272 001 R0014	55022 2		0.250	5
	1.6	S 202 M-C 1.6	2CDS 272 001 R0974	55021 5		0.250	5
	2	S 202 M-C 2	2CDS 272 001 R0024	55023 9		0.250	5
	3	S 202 M-C 3	2CDS 272 001 R0034	55024 6		0.250	5
	4	S 202 M-C 4	2CDS 272 001 R0044	55025 3		0.250	5
	6	S 202 M-C 6	2CDS 272 001 R0064	55026 0		0.250	5
	8	S 202 M-C 8	2CDS 272 001 R0084	55027 7		0.250	5
	10	S 202 M-C 10	2CDS 272 001 R0104	55028 4		0.250	5
	13	S 202 M-C 13	2CDS 272 001 R0134	55029 1		0.250	5
	16	S 202 M-C 16	2CDS 272 001 R0164	55030 7		0.250	5
	20	S 202 M-C 20	2CDS 272 001 R0204	55031 4		0.250	5
	25	S 202 M-C 25	2CDS 272 001 R0254	55032 1		0.250	5
	32	S 202 M-C 32	2CDS 272 001 R0324	55033 8		0.250	5
	40	S 202 M-C 40	2CDS 272 001 R0404	55034 5		0.250	5
	50	S 202 M-C 50	2CDS 272 001 R0504	54397 2		0.250	5
63	S 202 M-C 63	2CDS 272 001 R0634	54398 9		0.250	5	
U_{Bmax} 440 V ~ 125 V ...							
3	0.5	S 203 M-C 0.5	2CDS 273 001 R0984	55035 2		0.375	1
	1	S 203 M-C 1	2CDS 273 001 R0014	55037 6		0.375	1
	1.6	S 203 M-C 1.6	2CDS 273 001 R0974	55036 9		0.375	1
	2	S 203 M-C 2	2CDS 273 001 R0024	55038 3		0.375	1
	3	S 203 M-C 3	2CDS 273 001 R0034	55039 0		0.375	1
	4	S 203 M-C 4	2CDS 273 001 R0044	55040 6		0.375	1
	6	S 203 M-C 6	2CDS 273 001 R0064	55041 3		0.375	1
	8	S 203 M-C 8	2CDS 273 001 R0084	55042 0		0.375	1
	10	S 203 M-C 10	2CDS 273 001 R0104	55043 7		0.375	1
	13	S 203 M-C 13	2CDS 273 001 R0134	55044 4		0.375	1
	16	S 203 M-C 16	2CDS 273 001 R0164	55045 1		0.375	1
	20 ①	S 203 M-C 20	2CDS 273 001 R0204	55046 8		0.375	1
	25	S 203 M-C 25	2CDS 273 001 R0254	55047 5		0.375	1
	32 ②	S 203 M-C 32	2CDS 273 001 R0324	55048 2		0.375	1
	40 ③	S 203 M-C 40	2CDS 273 001 R0404	55049 9		0.375	1
	50	S 203 M-C 50	2CDS 273 001 R0504	54399 6		0.375	1
63	S 203 M-C 63	2CDS 273 001 R0634	54400 9		0.375	1	
U_{Bmax} 440 V ~							

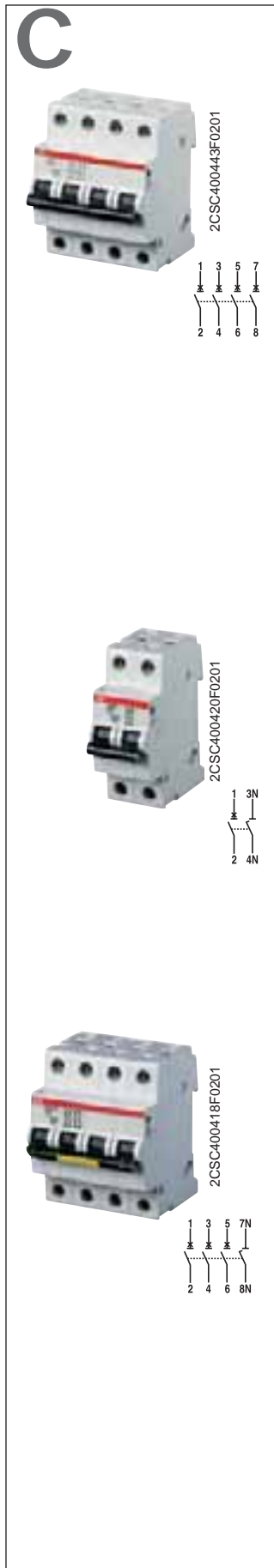

4	0.5	S 204 M-C	0.5	2CDS 274 001 R0984	55065 9	0.500	1
	1	S 204 M-C	1	2CDS 274 001 R0014	55067 3	0.500	1
	1.6	S 204 M-C	1.6	2CDS 274 001 R0974	55066 6	0.500	1
	2	S 204 M-C	2	2CDS 274 001 R0024	55068 0	0.500	1
	3	S 204 M-C	3	2CDS 274 001 R0034	55069 7	0.500	1
	4	S 204 M-C	4	2CDS 274 001 R0044	55070 3	0.500	1
	6	S 204 M-C	6	2CDS 274 001 R0064	55071 0	0.500	1
	8	S 204 M-C	8	2CDS 274 001 R0084	55072 7	0.500	1
	10	S 204 M-C	10	2CDS 274 001 R0104	55073 4	0.500	1
	13	S 204 M-C	13	2CDS 274 001 R0134	55074 1	0.500	1
	16	S 204 M-C	16	2CDS 274 001 R0164	55075 8	0.500	1
	20	S 204 M-C	20	2CDS 274 001 R0204	55076 5	0.500	1
	25	S 204 M-C	25	2CDS 274 001 R0254	55077 2	0.500	1
	32	S 204 M-C	32	2CDS 274 001 R0324	55078 9	0.500	1
	40	S 204 M-C	40	2CDS 274 001 R0404	55079 6	0.500	1
	④	50	S 204 M-C	50	2CDS 274 001 R0504	54403 0	0.500
	63	S 204 M-C	63	2CDS 274 001 R0634	54404 7	0.500	1

U_{Bmax}
440 V ~
125 V ∴

- ① suitable for flow-type heaters 12 kW ③ suitable for flow-type heaters 21, 24 and 27 kW
 ② suitable for flow-type heaters 18 kW ④ U_{Bmax} 125 V ∴ with 2 poles connected in series

With disconnecting neutral NA

Number of poles	Rated current	Order details	Bbn 4016779	Price 1 piece	Price group	Weight 1 piece	Pack unit
In A	Type code	Order code	EAN			kg	pc.
1 + NA	0.5	S 201 M-C 0.5 NA	2CDS 271 103 R0984	55005 5		0.250	5
	1	S 201 M-C 1 NA	2CDS 271 103 R0014	55007 9		0.250	5
	1.6	S 201 M-C 1.6 NA	2CDS 271 103 R0974	55006 2		0.250	5
	2	S 201 M-C 2 NA	2CDS 271 103 R0024	55008 6		0.250	5
	3	S 201 M-C 3 NA	2CDS 271 103 R0034	55009 3		0.250	5
	4	S 201 M-C 4 NA	2CDS 271 103 R0044	55010 9		0.250	5
	6	S 201 M-C 6 NA	2CDS 271 103 R0064	55011 6		0.250	5
	8	S 201 M-C 8 NA	2CDS 271 103 R0084	55012 3		0.250	5
	10	S 201 M-C 10 NA	2CDS 271 103 R0104	55013 0		0.250	5
	13	S 201 M-C 13 NA	2CDS 271 103 R0134	55014 7		0.250	5
	16	S 201 M-C 16 NA	2CDS 271 103 R0164	55015 4		0.250	5
	20 ①	S 201 M-C 20 NA	2CDS 271 103 R0204	55016 1		0.250	5
	25	S 201 M-C 25 NA	2CDS 271 103 R0254	55017 8		0.250	5
	32 ②	S 201 M-C 32 NA	2CDS 271 103 R0324	55018 5		0.250	5
	40 ③	S 201 M-C 40 NA	2CDS 271 103 R0404	55019 2		0.250	5
		50	S 201 M-C 50 NA	2CDS 271 103 R0504	54395 8		0.250
	63	S 201 M-C 63 NA	2CDS 271 103 R0634	54396 5		0.250	5

U_{Bmax}
253 V ~
72 V ∴

3 + NA	0.5	S 203 M-C 0.5 NA	2CDS 273 103 R0984	55051 2		0.500	1
	1	S 203 M-C 1 NA	2CDS 273 103 R0014	55052 9		0.500	1
	1.6	S 203 M-C 1.6 NA	2CDS 273 103 R0974	55050 5		0.500	1
	2	S 203 M-C 2 NA	2CDS 273 103 R0024	55053 6		0.500	1
	3	S 203 M-C 3 NA	2CDS 273 103 R0034	55054 3		0.500	1
	4	S 203 M-C 4 NA	2CDS 273 103 R0044	55055 0		0.500	1
	6	S 203 M-C 6 NA	2CDS 273 103 R0064	55056 7		0.500	1
	8	S 203 M-C 8 NA	2CDS 273 103 R0084	55057 4		0.500	1
	10	S 203 M-C 10 NA	2CDS 273 103 R0104	55058 1		0.500	1
	13	S 203 M-C 13 NA	2CDS 273 103 R0134	55059 8		0.500	1
	16	S 203 M-C 16 NA	2CDS 273 103 R0164	55060 4		0.500	1
	20 ①	S 203 M-C 20 NA	2CDS 273 103 R0204	55061 1		0.500	1
	25	S 203 M-C 25 NA	2CDS 273 103 R0254	55062 8		0.500	1
	32 ②	S 203 M-C 32 NA	2CDS 273 103 R0324	55063 5		0.500	1
	40 ③	S 203 M-C 40 NA	2CDS 273 103 R0404	55064 2		0.500	1
		50	S 203 M-C 50 NA	2CDS 273 103 R0504	54401 6		0.580
	63	S 203 M-C 63 NA	2CDS 273 103 R0634	54402 3		0.580	1

U_{Bmax}
440 V ~

- ① suitable for flow-type heaters 12 kW ③ suitable for flow-type heaters 21, 24 and 27 kW
 ② suitable for flow-type heaters 18 kW

10000

D



2CSC400424F0201



2CSC400425F0201



2CSC400426F0201



S 200 M-D characteristic

Function: protection and control of the circuits against overloads and short-circuits; protection for circuits which supply loads with high inrush current at the circuit closing (LV/LV transformers, break-down lamps).

Applications: residential, commercial and industrial.

Standard: IEC/EN 60898, IEC/EN 60947-2

I_{cn}=10 kA

Number of poles	Rated current	Order details	Bbn 4016779	Price 1 piece	Price group	Weight 1 piece	Pack unit
In A	Type code	Order code	EAN			kg	pc.
1	0.5	S 201 M-D 0.5	2CDS 271 001 R0981	59983 2		0.125	10
	1	S 201 M-D 1	2CDS 271 001 R0011	50031 3		0.125	10
	1.6	S 201 M-D 1.6	2CDS 271 001 R0971	59982 5		0.125	10
	2	S 201 M-D 2	2CDS 271 001 R0021	59933 7		0.125	10
	3	S 201 M-D 3	2CDS 271 001 R0031	59935 1		0.125	10
	4	S 201 M-D 4	2CDS 271 001 R0041	59935 7		0.125	10
	6	S 201 M-D 6	2CDS 271 001 R0061	59939 9		0.125	10
	8	S 201 M-D 8	2CDS 271 001 R0081	59940 5		0.125	10
	10	S 201 M-D 10	2CDS 271 001 R0101	59942 9		0.125	10
	13	S 201 M-D 13	2CDS 271 001 R0131	66326 7		0.125	10
	16	S 201 M-D 16	2CDS 271 001 R0161	59945 0		0.125	10
	20 ①	S 201 M-D 20	2CDS 271 001 R0201	50046 7		0.125	10
	25	S 201 M-D 25	2CDS 271 001 R0251	59949 8		0.125	10
	32 ②	S 201 M-D 32	2CDS 271 001 R0321	59956 6		0.125	10
	40 ③	S 201 M-D 40	2CDS 271 001 R0401	59961 0		0.125	10
	50	S 201 M-D 50	2CDS 271 001 R0501	59970 2		0.125	10
63	S 201 M-D 63	2CDS 271 001 R0631	59981 8		0.125	10	
U_{Bmax} 253 V ~ 72 V ...							
2	0.5	S 202 M-D 0.5	2CDS 272 001 R0981	60088 0		0.250	5
	1	S 202 M-D 1	2CDS 272 001 R0011	60036 1		0.250	5
	1.6	S 202 M-D 1.6	2CDS 272 001 R0971	60087 3		0.250	5
	2	S 202 M-D 2	2CDS 272 001 R0021	60038 5		0.250	5
	3	S 202 M-D 3	2CDS 272 001 R0031	60040 8		0.250	5
	4	S 202 M-D 4	2CDS 272 001 R0041	60042 2		0.250	5
	6	S 202 M-D 6	2CDS 272 001 R0061	60044 6		0.250	5
	8	S 202 M-D 8	2CDS 272 001 R0081	60045 3		0.250	5
	10	S 202 M-D 10	2CDS 272 001 R0101	60047 7		0.250	5
	13	S 202 M-D 13	2CDS 272 001 R0131	66327 4		0.250	5
	16	S 202 M-D 16	2CDS 272 001 R0161	60050 7		0.250	5
	20	S 202 M-D 20	2CDS 272 001 R0201	60051 4		0.250	5
	25	S 202 M-D 25	2CDS 272 001 R0251	60054 5		0.250	5
	32	S 202 M-D 32	2CDS 272 001 R0321	60061 3		0.250	5
	40	S 202 M-D 40	2CDS 272 001 R0401	60066 8		0.250	5
	50	S 202 M-D 50	2CDS 272 001 R0501	60075 0		0.250	5
63	S 202 M-D 63	2CDS 272 001 R0631	60086 6		0.250	5	
U_{Bmax} 440 V ~ 125 V ... ④							
3	0.5	S 203 M-D 0.5	2CDS 273 001 R0981	60141 2		0.375	1
	1	S 203 M-D 1	2CDS 273 001 R0011	60089 7		0.375	1
	1.6	S 203 M-D 1.6	2CDS 273 001 R0971	60140 5		0.375	1
	2	S 203 M-D 2	2CDS 273 001 R0021	60091 0		0.375	1
	3	S 203 M-D 3	2CDS 273 001 R0031	60093 4		0.375	1
	4	S 203 M-D 4	2CDS 273 001 R0041	60095 8		0.375	1
	6	S 203 M-D 6	2CDS 273 001 R0061	60097 2		0.375	1
	8	S 203 M-D 8	2CDS 273 001 R0081	60098 9		0.375	1
	10	S 203 M-D 10	2CDS 273 001 R0101	60100 9		0.375	1
	13	S 203 M-D 13	2CDS 273 001 R0131	66328 1		0.375	1
	16	S 203 M-D 16	2CDS 273 001 R0161	60103 0		0.375	1
	20 ①	S 203 M-D 20	2CDS 273 001 R0201	60104 7		0.375	1
	25	S 203 M-D 25	2CDS 273 001 R0251	60107 8		0.375	1
	32 ②	S 203 M-D 32	2CDS 273 001 R0321	60114 6		0.375	1
	40 ③	S 203 M-D 40	2CDS 273 001 R0401	60119 1		0.375	1
	50	S 203 M-D 50	2CDS 273 001 R0501	60128 3		0.375	1
63	S 203 M-D 63	2CDS 273 001 R0631	60139 9		0.375	1	
U_{Bmax} 440 V ~							

10000

2

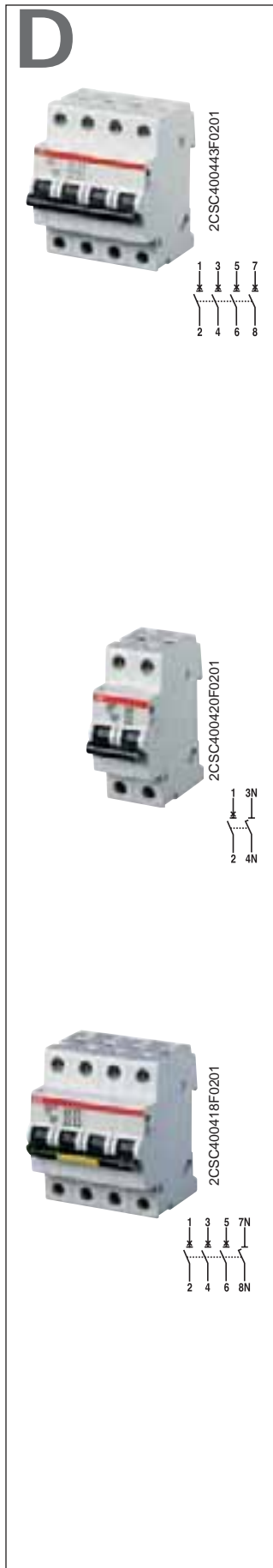

Number of poles	Rated current	Type code	Order code	EAN	Price 1 piece	Weight 1 piece	Pack unit
4	0.5	S 204 M-D 0.5	2CDS 274 001 R0981	60214 3	0.500	1	
	1	S 204 M-D 1	2CDS 274 001 R0011	60163 4	0.500	1	
	1.6	S 204 M-D 1.6	2CDS 274 001 R0971	60213 6	0.500	1	
	2	S 204 M-D 2	2CDS 274 001 R0021	60165 8	0.500	1	
	3	S 204 M-D 3	2CDS 274 001 R0031	60167 2	0.500	1	
	4	S 204 M-D 4	2CDS 274 001 R0041	60169 6	0.500	1	
	6	S 204 M-D 6	2CDS 274 001 R0061	60171 9	0.500	1	
	8	S 204 M-D 8	2CDS 274 001 R0081	60172 6	0.500	1	
	10	S 204 M-D 10	2CDS 274 001 R0101	60174 0	0.500	1	
	13	S 204 M-D 13	2CDS 274 001 R0131	66329 8	0.500	1	
	16	S 204 M-D 16	2CDS 274 001 R0161	60177 1	0.500	1	
	20	S 204 M-D 20	2CDS 274 001 R0201	60178 8	0.500	1	
	25	S 204 M-D 25	2CDS 274 001 R0251	60181 8	0.500	1	
	32	S 204 M-D 32	2CDS 274 001 R0321	60188 7	0.500	1	
	40	S 204 M-D 40	2CDS 274 001 R0401	60193 1	0.500	1	
	50	S 204 M-D 50	2CDS 274 001 R0501	60201 3	0.500	1	
④ 63	S 204 M-D 63	2CDS 274 001 R0631	60212 9	0.500	1		

U_{Bmax}
440 V ~
125 V ∴

- ① suitable for flow-type heaters 12 kW
- ② suitable for flow-type heaters 18 kW
- ③ suitable for flow-type heaters 21, 24 and 27 kW
- ④ U_{Bmax} 125 V ∴ with 2 poles connected in series

With disconnecting neutral NA

Number of poles	Rated current	Type code	Order code	EAN	Price 1 piece	Weight 1 piece	Pack unit
1 + NA	0.5	S 201 M-D 0.5 NA	2CDS 271 103 R0981	60035 4		0.250	5
	1	S 201 M-D 1 NA	2CDS 271 103 R0011	59984 9		0.250	5
	1.6	S 201 M-D 1.6 NA	2CDS 271 103 R0971	60034 7		0.250	5
	2	S 201 M-D 2 NA	2CDS 271 103 R0021	59986 3		0.250	5
	3	S 201 M-D 3 NA	2CDS 271 103 R0031	59988 7		0.250	5
	4	S 201 M-D 4 NA	2CDS 271 103 R0041	59990 0		0.250	5
	6	S 201 M-D 6 NA	2CDS 271 103 R0061	59992 4		0.250	5
	8	S 201 M-D 8 NA	2CDS 271 103 R0081	59993 1		0.250	5
	10	S 201 M-D 10 NA	2CDS 271 103 R0101	59994 8		0.250	5
	13	S 201 M-D 13 NA	2CDS 271 103 R0131	66330 4		0.250	5
	16	S 201 M-D 16 NA	2CDS 271 103 R0161	59997 9		0.250	5
	20 ①	S 201 M-D 20 NA	2CDS 271 103 R0201	59998 6		0.250	5
	25	S 201 M-D 25 NA	2CDS 271 103 R0251	60001 9		0.250	5
	32 ②	S 201 M-D 32 NA	2CDS 271 103 R0321	60008 8	0.250	5	
	40 ③	S 201 M-D 40 NA	2CDS 271 103 R0401	60013 2		0.250	5
	50	S 201 M-D 50 NA	2CDS 271 103 R0501	60022 4		0.290	5
63	S 201 M-D 63 NA	2CDS 271 103 R0631	60033 0		0.290	5	

U_{Bmax}
253 V ~
72 V ∴

- ① suitable for flow-type heaters 12 kW
- ② suitable for flow-type heaters 18 kW
- ③ suitable for flow-type heaters 21, 24 and 27 kW

10000

K



2CSC400424F0201



2CDC021171F0006



2CSC400426F0201



S 200 M-K (power) characteristic

Function: protection and control of the circuits like motors, transformer and auxiliary circuits, against overloads and short-circuits.

Advantages: no nuisance tripping in the case of functional peak currents up to 10xI_n, depending on the series; through its highly sensitive thermostatic bimetal trip, the K-type characteristic offers protection to damageable elements in the overcurrent range; it also provides the best protection to cables and lines.

Applications: commercial and industrial.

Standard: IEC/EN 60947-2, VDE 0660 Part 101

I_{cu}=10 kA (acc. to VDE 0660 Part 101)

Number of poles	Rated current	Order details	Bbn	Price	Price group	Weight	Pack unit
			4016779	1 piece		1 piece	
In A	Type code	Order code	EAN			kg	pc.
1	0.5	S 201 M-K 0.5	2CDS 271 001 R0157	59943 6		0.125	10
	1	S 201 M-K 1	2CDS 271 001 R0217	59947 4		0.125	10
	1.6	S 201 M-K 1.6	2CDS 271 001 R0257	59950 4		0.125	10
	2	S 201 M-K 2	2CDS 271 001 R0277	59952 8		0.125	10
	3	S 201 M-K 3	2CDS 271 001 R0317	59954 2		0.125	10
	4	S 201 M-K 4	2CDS 271 001 R0337	59957 3		0.125	10
	6	S 201 M-K 6	2CDS 271 001 R0377	59959 7		0.125	10
	8	S 201 M-K 8	2CDS 271 001 R0407	59962 7		0.125	10
	10	S 201 M-K 10	2CDS 271 001 R0427	59964 1		0.125	10
	13	S 201 M-K 13	2CDS 271 001 R0447	65939 0		0.125	10
	16	S 201 M-K 16	2CDS 271 001 R0467	59966 5		0.125	10
	20	S 201 M-K 20	2CDS 271 001 R0487	59968 9		0.125	10
	25	S 201 M-K 25	2CDS 271 001 R0517	59971 9		0.125	10
	32	S 201 M-K 32	2CDS 271 001 R0537	59973 3		0.125	10
	40	S 201 M-K 40	2CDS 271 001 R0557	59975 7		0.125	10
	50	S 201 M-K 50	2CDS 271 001 R0577	59977 1		0.125	10
63	S 201 M-K 63	2CDS 271 001 R0607	59979 5		0.125	10	
2	0.5	S 202 M-K 0.5	2CDS 272 001 R0157	60048 4		0.250	5
	1	S 202 M-K 1	2CDS 272 001 R0217	60052 1		0.250	5
	1.6	S 202 M-K 1.6	2CDS 272 001 R0257	60055 2		0.250	5
	2	S 202 M-K 2	2CDS 272 001 R0277	60057 6		0.250	5
	3	S 202 M-K 3	2CDS 272 001 R0317	60059 0		0.250	5
	4	S 202 M-K 4	2CDS 272 001 R0337	60062 0		0.250	5
	6	S 202 M-K 6	2CDS 272 001 R0377	60064 4		0.250	5
	8	S 202 M-K 8	2CDS 272 001 R0407	60067 5		0.250	5
	10	S 202 M-K 10	2CDS 272 001 R0427	60069 9		0.250	5
	13	S 202 M-K 13	2CDS 272 001 R0447	65940 6		0.250	5
	16	S 202 M-K 16	2CDS 272 001 R0467	60071 2		0.250	5
	20	S 202 M-K 20	2CDS 272 001 R0487	60073 6		0.250	5
	25	S 202 M-K 25	2CDS 272 001 R0517	60076 7		0.250	5
	32	S 202 M-K 32	2CDS 272 001 R0537	60078 1		0.250	5
	40	S 202 M-K 40	2CDS 272 001 R0557	60080 4		0.250	5
	50	S 202 M-K 50	2CDS 272 001 R0577	60082 8		0.250	5
63	S 202 M-K 63	2CDS 272 001 R0607	60084 2		0.250	5	
3	0.5	S 203 M-K 0.5	2CDS 273 001 R0157	60101 6		0.375	1
	1	S 203 M-K 1	2CDS 273 001 R0217	60105 4		0.375	1
	1.6	S 203 M-K 1.6	2CDS 273 001 R0257	60108 5		0.375	1
	2	S 203 M-K 2	2CDS 273 001 R0277	60110 8		0.375	1
	3	S 203 M-K 3	2CDS 273 001 R0317	60112 2		0.375	1
	4	S 203 M-K 4	2CDS 273 001 R0337	60115 3		0.375	1
	6	S 203 M-K 6	2CDS 273 001 R0377	60117 7		0.375	1
	8	S 203 M-K 8	2CDS 273 001 R0407	60120 7		0.375	1
	10	S 203 M-K 10	2CDS 273 001 R0427	60122 1		0.375	1
	13	S 203 M-K 13	2CDS 273 001 R0447	65941 3		0.375	1
	16	S 203 M-K 16	2CDS 273 001 R0467	60124 5		0.375	1
	20	S 203 M-K 20	2CDS 273 001 R0487	60126 9		0.375	1
	25	S 203 M-K 25	2CDS 273 001 R0517	60129 0		0.375	1
	32	S 203 M-K 32	2CDS 273 001 R0537	60131 3		0.375	1
	40	S 203 M-K 40	2CDS 273 001 R0557	60133 7		0.375	1
	50	S 203 M-K 50	2CDS 273 001 R0577	60135 1		0.375	1
63	S 203 M-K 63	2CDS 273 001 R0607	60137 5		0.375	1	

U_{Bmax}
253 V ~
72 V ∴

U_{Bmax}
440 V ~
125 V ∴

①

U_{Bmax}
440 V ~

10000

2

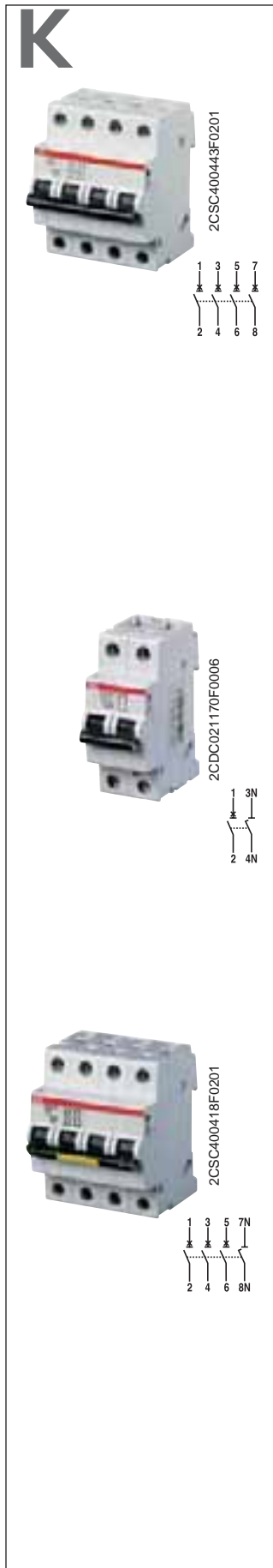

4	0.5	S 204 M-K	0.5	2CDS 274 001 R0157	60175 7	0.500	1
	1	S 204 M-K	1	2CDS 274 001 R0217	60179 5	0.500	1
	1.6	S 204 M-K	1.6	2CDS 274 001 R0257	60182 5	0.500	1
	2	S 204 M-K	2	2CDS 274 001 R0277	60184 9	0.500	1
	3	S 204 M-K	3	2CDS 274 001 R0317	60186 3	0.500	1
	4	S 204 M-K	4	2CDS 274 001 R0337	60189 4	0.500	1
	6	S 204 M-K	6	2CDS 274 001 R0377	60191 7	0.500	1
	8	S 204 M-K	8	2CDS 274 001 R0407	60194 8	0.500	1
	10	S 204 M-K	10	2CDS 274 001 R0427	60196 2	0.500	1
	13	S 204 M-K	13	2CDS 274 001 R0447	65942 0	0.500	1
	16	S 204 M-K	16	2CDS 274 001 R0467	60198 6	0.500	1
	20	S 204 M-K	20	2CDS 274 001 R0487	60200 6	0.500	1
	25	S 204 M-K	25	2CDS 274 001 R0517	60202 0	0.500	1
	32	S 204 M-K	32	2CDS 274 001 R0537	60204 4	0.500	1
	40	S 204 M-K	40	2CDS 274 001 R0557	60206 8	0.500	1
50	S 204 M-K	50	2CDS 274 001 R0577	60208 2	0.500	1	
125 V ...	63	S 204 M-K	63	2CDS 274 001 R0607	60210 5	0.500	1

U_{Bmax}
440 V ~
125 V ...

① U_{Bmax} 125 V ... with 2 poles connected in series

With disconnecting neutral NA

Number of poles	Rated current	Order details	Bbn 4016779	Price 1 piece	Price group	Weight 1 piece	Pack unit
	In A	Type code	Order code	EAN		kg	pc.
1	0.5	S 201 M-K	0.5 NA	2CDS 271 103 R0157	59995 5	0.250	5
	1	S 201 M-K	1 NA	2CDS 271 103 R0217	59999 3	0.250	5
	1.6	S 201 M-K	1.6 NA	2CDS 271 103 R0257	60002 6	0.250	5
	2	S 201 M-K	2 NA	2CDS 271 103 R0277	60004 0	0.250	5
	3	S 201 M-K	3 NA	2CDS 271 103 R0317	60006 4	0.250	5
	4	S 201 M-K	4 NA	2CDS 271 103 R0337	60009 5	0.250	5
	6	S 201 M-K	6 NA	2CDS 271 103 R0377	60011 8	0.250	5
	8	S 201 M-K	8 NA	2CDS 271 103 R0407	60014 9	0.250	5
	10	S 201 M-K	10 NA	2CDS 271 103 R0427	60016 3	0.250	5
	13	S 201 M-K	13 NA	2CDS 271 103 R0447	65943 7	0.250	5
	16	S 201 M-K	16 NA	2CDS 271 103 R0467	60018 7	0.250	5
	20	S 201 M-K	20 NA	2CDS 271 103 R0487	60020 0	0.250	5
	25	S 201 M-K	25 NA	2CDS 271 103 R0517	60023 1	0.250	5
	32	S 201 M-K	32 NA	2CDS 271 103 R0537	60025 5	0.250	5
	40	S 201 M-K	40 NA	2CDS 271 103 R0557	60027 9	0.250	5
50	S 201 M-K	50 NA	2CDS 271 103 R0577	60029 3	0.250	5	
63	S 201 M-K	63 NA	2CDS 271 103 R0607	60031 6	0.250	5	

U_{Bmax}
253 V ~
72 V ...

3	0.5	S 203 M-K	0.5 NA	2CDS 273 103 R0157	65944 4	0.500	1
	1	S 203 M-K	1 NA	2CDS 273 103 R0217	65045 1	0.500	1
	1.6	S 203 M-K	1.6 NA	2CDS 273 103 R0257	65946 8	0.500	1
	2	S 203 M-K	2 NA	2CDS 273 103 R0277	65947 5	0.500	1
	3	S 203 M-K	3 NA	2CDS 273 103 R0317	65948 2	0.500	1
	4	S 203 M-K	4 NA	2CDS 273 103 R0337	65949 9	0.500	1
	6	S 203 M-K	6 NA	2CDS 273 103 R0377	65950 5	0.500	1
	8	S 203 M-K	8 NA	2CDS 273 103 R0407	65951 2	0.500	1
	10	S 203 M-K	10 NA	2CDS 273 103 R0427	65952 9	0.500	1
	13	S 203 M-K	13 NA	2CDS 273 103 R0447	65953 6	0.500	1
	16	S 203 M-K	16 NA	2CDS 273 103 R0467	65954 3	0.500	1
	20	S 203 M-K	20 NA	2CDS 273 103 R0487	65955 0	0.500	1
	25	S 203 M-K	25 NA	2CDS 273 103 R0517	65956 7	0.500	1
	32	S 203 M-K	32 NA	2CDS 273 103 R0537	65957 4	0.500	1
	40	S 203 M-K	40 NA	2CDS 273 103 R0557	65958 1	0.500	1
50	S 203 M-K	50 NA	2CDS 273 103 R0577	65960 4	0.500	1	
63	S 203 M-K	63 NA	2CDS 273 103 R0607	65961 1	0.500	1	

U_{Bmax}
440 V ~

10000

Z



2CSC400424F0201



2CDC021205F0006



2CSC400426F0201



S 200 M-Z characteristic

Function: protection and control of the electronic circuits against weak and long duration overloads and short-circuits.

Applications: commercial and industrial.

Standard: IEC/EN 60947-2, VDE 0660 Part 101

Icu=10 kA (acc. to VDE 0660 Part 101)

Number of poles	Rated current	Order details	In A	Type code	Order code	Bbn	Price 1 piece	Price group	Weight 1 piece	Pack unit
						4016779				
						EAN			kg	pc.
1	0.5	S 201 M-Z 0.5	0.5		2CDS 271 001 R0158	59944 3			0.125	10
	1	S 201 M-Z 1	1		2CDS 271 001 R0218	59948 1			0.125	10
	1.6	S 201 M-Z 1.6	1.6		2CDS 271 001 R0258	59951 1			0.125	10
	2	S 201 M-Z 2	2		2CDS 271 001 R0278	59953 5			0.125	10
	3	S 201 M-Z 3	3		2CDS 271 001 R0318	59955 9			0.125	10
	4	S 201 M-Z 4	4		2CDS 271 001 R0338	59958 0			0.125	10
	6	S 201 M-Z 6	6		2CDS 271 001 R0378	59960 3			0.125	10
	8	S 201 M-Z 8	8		2CDS 271 001 R0408	59963 4			0.125	10
	10	S 201 M-Z 10	10		2CDS 271 001 R0428	59965 8			0.125	10
	16	S 201 M-Z 16	16		2CDS 271 001 R0468	59967 2			0.125	10
	20	S 201 M-Z 20	20		2CDS 271 001 R0488	59969 6			0.125	10
	25	S 201 M-Z 25	25		2CDS 271 001 R0518	59972 6			0.125	10
	32	S 201 M-Z 32	32		2CDS 271 001 R0538	59974 0			0.125	10
	40	S 201 M-Z 40	40		2CDS 271 001 R0558	59976 4			0.125	10
2	0.5	S 202 M-Z 0.5	0.5		2CDS 272 001 R0158	60049 1			0.250	5
	1	S 202 M-Z 1	1		2CDS 272 001 R0218	60053 8			0.250	5
	1.6	S 202 M-Z 1.6	1.6		2CDS 272 001 R0258	60056 9			0.250	5
	2	S 202 M-Z 2	2		2CDS 272 001 R0278	60058 3			0.250	5
	3	S 202 M-Z 3	3		2CDS 272 001 R0318	60060 6			0.250	5
4	S 202 M-Z 4	4		2CDS 272 001 R0338	60063 7			0.250	5	
6	S 202 M-Z 6	6		2CDS 272 001 R0378	60065 1			0.250	5	
8	S 202 M-Z 8	8		2CDS 272 001 R0408	60068 2			0.250	5	
10	S 202 M-Z 10	10		2CDS 272 001 R0428	60070 5			0.250	5	
16	S 202 M-Z 16	16		2CDS 272 001 R0468	60072 9			0.250	5	
20	S 202 M-Z 20	20		2CDS 272 001 R0488	60074 3			0.250	5	
25	S 202 M-Z 25	25		2CDS 272 001 R0518	60077 4			0.250	5	
32	S 202 M-Z 32	32		2CDS 272 001 R0538	60079 8			0.250	5	
40	S 202 M-Z 40	40		2CDS 272 001 R0558	60081 1			0.250	5	
50	S 202 M-Z 50	50		2CDS 272 001 R0578	60083 5			0.250	5	
63	S 202 M-Z 63	63		2CDS 272 001 R0608	60085 9			0.250	5	
3	0.5	S 203 M-Z 0.5	0.5		2CDS 273 001 R0158	60102 3			0.375	1
	1	S 203 M-Z 1	1		2CDS 273 001 R0218	60106 1			0.375	1
	1.6	S 203 M-Z 1.6	1.6		2CDS 273 001 R0258	60109 2			0.375	1
	2	S 203 M-Z 2	2		2CDS 273 001 R0278	60111 5			0.375	1
	3	S 203 M-Z 3	3		2CDS 273 001 R0318	60113 9			0.375	1
	4	S 203 M-Z 4	4		2CDS 273 001 R0338	60116 0			0.375	1
	6	S 203 M-Z 6	6		2CDS 273 001 R0378	60118 4			0.375	1
	8	S 203 M-Z 8	8		2CDS 273 001 R0408	60121 4			0.375	1
	10	S 203 M-Z 10	10		2CDS 273 001 R0428	60123 8			0.375	1
	16	S 203 M-Z 16	16		2CDS 273 001 R0468	60125 2			0.375	1
	20	S 203 M-Z 20	20		2CDS 273 001 R0488	60127 6			0.375	1
	25	S 203 M-Z 25	25		2CDS 273 001 R0518	60130 6			0.375	1
	32	S 203 M-Z 32	32		2CDS 273 001 R0538	60132 0			0.375	1
	40	S 203 M-Z 40	40		2CDS 273 001 R0558	60134 4			0.375	1
50	S 203 M-Z 50	50		2CDS 273 001 R0578	60136 8			0.375	1	
63	S 203 M-Z 63	63		2CDS 273 001 R0608	60138 2			0.375	1	

U_{Bmax}
253 V ~
72 V ...

U_{Bmax}
440 V ~
125 V ...

①

U_{Bmax}
440 V ~

10000

2

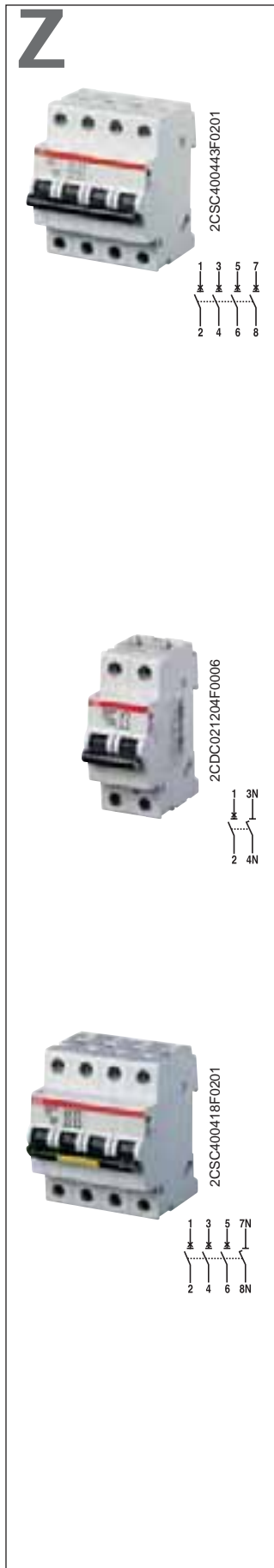

4	0.5	S 204 M-Z	0.5	2CDS 274 001 R0158	60176 4	0.500	1
	1	S 204 M-Z	1	2CDS 274 001 R0218	60181 0	0.500	1
	1.6	S 204 M-Z	1.6	2CDS 274 001 R0258	60183 2	0.500	1
	2	S 204 M-Z	2	2CDS 274 001 R0278	60185 6	0.500	1
	3	S 204 M-Z	3	2CDS 274 001 R0318	60187 0	0.500	1
	4	S 204 M-Z	4	2CDS 274 001 R0338	60190 0	0.500	1
	6	S 204 M-Z	6	2CDS 274 001 R0378	60192 4	0.500	1
	8	S 204 M-Z	8	2CDS 274 001 R0408	60195 5	0.500	1
	10	S 204 M-Z	10	2CDS 274 001 R0428	60197 9	0.500	1
	16	S 204 M-Z	16	2CDS 274 001 R0468	60199 3	0.500	1
	20	S 204 M-Z	20	2CDS 274 001 R0488	65962 8	0.500	1
	25	S 204 M-Z	25	2CDS 274 001 R0518	60203 7	0.500	1
	32	S 204 M-Z	32	2CDS 274 001 R0538	60205 1	0.500	1
	40	S 204 M-Z	40	2CDS 274 001 R0558	60207 5	0.500	1
50	S 204 M-Z	50	2CDS 274 001 R0578	60209 9	0.500	1	
63	S 204 M-Z	63	2CDS 274 001 R0608	60211 2	0.500	1	

U_{Bmax}
440 V ~
125 V ∴

① U_{Bmax} 125 V ∴ with 2 poles connected in series

With disconnecting neutral NA

Number of poles	Rated current	Order details	Bbn 4016779	Price 1 piece	Price group	Weight 1 piece	Pack unit	
In A	Type code	Order code	EAN	kg	pc.			
1 +	0.5	S 201 M-Z 0.5 NA	2CDS 271 103 R0158	59996 2		0.260	5	
	1	S 201 M-Z 1 NA	2CDS 271 103 R0218	60000 2		0.260	5	
	NA	1.6	S 201 M-Z 1.6 NA	2CDS 271 103 R0258	60003 3		0.260	5
		2	S 201 M-Z 2 NA	2CDS 271 103 R0278	60005 7		0.260	5
		3	S 201 M-Z 3 NA	2CDS 271 103 R0318	60007 1		0.260	5
		4	S 201 M-Z 4 NA	2CDS 271 103 R0338	60010 1		0.260	5
		6	S 201 M-Z 6 NA	2CDS 271 103 R0378	60012 5		0.260	5
		8	S 201 M-Z 8 NA	2CDS 271 103 R0408	60015 6		0.260	5
		10	S 201 M-Z 10 NA	2CDS 271 103 R0428	60017 0		0.260	5
		16	S 201 M-Z 16 NA	2CDS 271 103 R0468	60019 4		0.260	5
		20	S 201 M-Z 20 NA	2CDS 271 103 R0488	60021 7		0.260	5
		25	S 201 M-Z 25 NA	2CDS 271 103 R0518	60024 8		0.260	5
	32	S 201 M-Z 32 NA	2CDS 271 103 R0538	60026 2		0.260	5	
	40	S 201 M-Z 40 NA	2CDS 271 103 R0558	60028 6		0.260	5	
50	S 201 M-Z 50 NA	2CDS 271 103 R0578	60030 9		0.320	5		
63	S 201 M-Z 63 NA	2CDS 271 103 R0608	60032 3		0.320	5		
U _{Bmax} 253 V ~ 72 V ∴								
3 +	0.5	S 203 M-Z 0.5 NA	2CDS 273 103 R0158	60147 4	0.520	1		
	1	S 203 M-Z 1 NA	2CDS 273 103 R0218	60148 1		0.520	1	
	NA	1.6	S 203 M-Z 1.6 NA	2CDS 273 103 R0258	60149 8		0.520	1
		2	S 203 M-Z 2 NA	2CDS 273 103 R0278	60150 4		0.520	1
		3	S 203 M-Z 3 NA	2CDS 273 103 R0318	60151 1		0.520	1
		4	S 203 M-Z 4 NA	2CDS 273 103 R0338	60152 8		0.520	1
		6	S 203 M-Z 6 NA	2CDS 273 103 R0378	60153 5		0.520	1
		8	S 203 M-Z 8 NA	2CDS 273 103 R0408	60154 2		0.520	1
		10	S 203 M-Z 10 NA	2CDS 273 103 R0428	60155 9		0.520	1
		16	S 203 M-Z 16 NA	2CDS 273 103 R0468	60156 6		0.520	1
		20	S 203 M-Z 20 NA	2CDS 273 103 R0488	60157 3		0.520	1
		25	S 203 M-Z 25 NA	2CDS 273 103 R0518	60158 0		0.520	1
	32	S 203 M-Z 32 NA	2CDS 273 103 R0538	60159 7		0.520	1	
	40	S 203 M-Z 40 NA	2CDS 273 103 R0558	60160 3		0.520	1	
50	S 203 M-Z 50 NA	2CDS 273 103 R0578	60161 0		0.640	1		
63	S 203 M-Z 63 NA	2CDS 273 103 R0608	60162 7		0.640	1		
U _{Bmax} 440 V ~								

B

2

S 200 P-B characteristic

Function: protection and control of the circuits against overloads and short-circuits; protection for people and big length cables in TN and IT systems.

Applications: commercial and industrial.

Standard: IEC/EN 60898

$I_{cn}=25 \text{ kA}$ for $0.5 \text{ A} \leq I_n \leq 25 \text{ A}$

$I_{cn}=15 \text{ kA}$ for $32 \text{ A} \leq I_n \leq 63 \text{ A}$

Number of poles	Rated current	Order details	Bbn 4016779	Price 1 piece	Price group	Weight 1 piece	Pack unit
1	6	S 201 P-B 6	2CDS 281 001 R0065	589574		0.14	10
	10	S 201 P-B 10	2CDS 281 001 R0105	589581		0.14	10
	13	S 201 P-B 13	2CDS 281 001 R0135	589598		0.14	10
	16	S 201 P-B 16	2CDS 281 001 R0165	589260		0.14	10
	20	S 201 P-B 20	2CDS 281 001 R0205	589604		0.14	10
	25	S 201 P-B 25	2CDS 281 001 R0255	589611		0.14	10
	32	S 201 P-B 32	2CDS 281 001 R0325	589628		0.14	10
	40	S 201 P-B 40	2CDS 281 001 R0405	589635		0.14	10
	50	S 201 P-B 50	2CDS 281 001 R0505	589659		0.14	10
	63	S 201 P-B 63	2CDS 281 001 R0635	589666		0.14	10

2	6	S 202 P-B 6	2CDS 282 001 R0065	589673		0.28	5
	10	S 202 P-B 10	2CDS 282 001 R0105	589680		0.28	5
	13	S 202 P-B 13	2CDS 282 001 R0135	589697		0.28	5
	16	S 202 P-B 16	2CDS 282 001 R0165	589703		0.28	5
	20	S 202 P-B 20	2CDS 282 001 R0205	589710		0.28	5
	25	S 202 P-B 25	2CDS 282 001 R0255	589727		0.28	5
	32	S 202 P-B 32	2CDS 282 001 R0325	589734		0.28	5
	40	S 202 P-B 40	2CDS 282 001 R0405	589741		0.28	5
	50	S 202 P-B 50	2CDS 282 001 R0505	589758		0.28	5
	63	S 202 P-B 63	2CDS 282 001 R0635	589765		0.28	5

3	6	S 203 P-B 6	2CDS 283 001 R0065	589772		0.42	1
	10	S 203 P-B 10	2CDS 283 001 R0105	589789		0.42	1
	13	S 203 P-B 13	2CDS 283 001 R0135	589796		0.42	1
	16	S 203 P-B 16	2CDS 283 001 R0165	589802		0.42	1
	20	S 203 P-B 20	2CDS 283 001 R0205	589819		0.42	1
	25	S 203 P-B 25	2CDS 283 001 R0255	589826		0.42	1
	32	S 203 P-B 32	2CDS 283 001 R0325	589833		0.42	1
	40	S 203 P-B 40	2CDS 283 001 R0405	589840		0.42	1
	50	S 203 P-B 50	2CDS 283 001 R0505	589857		0.42	1
	63	S 203 P-B 63	2CDS 283 001 R0635	589864		0.42	1

4	6	S 204 P-B 6	2CDS 284 001 R0065	589871		0.56	1
	10	S 204 P-B 10	2CDS 284 001 R0105	589888		0.56	1
	13	S 204 P-B 13	2CDS 284 001 R0135	589895		0.56	1
	16	S 204 P-B 16	2CDS 284 001 R0165	589901		0.56	1
	20	S 204 P-B 20	2CDS 284 001 R0205	589918		0.56	1
	25	S 204 P-B 25	2CDS 284 001 R0255	589925		0.56	1
	32	S 204 P-B 32	2CDS 284 001 R0325	589932		0.56	1
	40	S 204 P-B 40	2CDS 284 001 R0405	589949		0.56	1
	50	S 204 P-B 50	2CDS 284 001 R0505	589956		0.56	1
	63	S 204 P-B 63	2CDS 284 001 R0635	589963		0.56	1

① U_{Bmax} 125 V ∴ with 2 poles connected in series

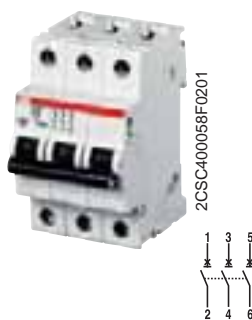

B

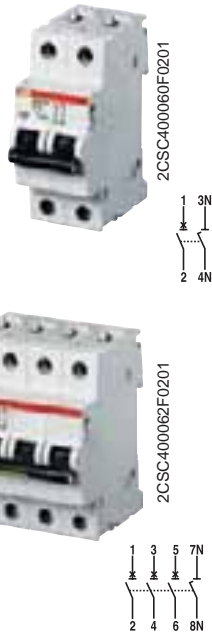

With disconnecting neutral NA

Number of poles	Rated current	Order details	Bbn 4016779	Price 1 piece	Price group	Weight 1 piece	Pack unit	
	In A	Type code	Order code	EAN		kg	pc.	
1	6	S 201 P-B 6 NA	2CDS 281 103 R0065	589970		0.28	5	
	10	S 201 P-B 10 NA	2CDS 281 103 R0105	589987		0.28	5	
	NA	13	S 201 P-B 13 NA	2CDS 281 103 R0135	589994		0.28	5
		16	S 201 P-B 16 NA	2CDS 281 103 R0165	590006		0.28	5
		20	S 201 P-B 20 NA	2CDS 281 103 R0205	590013		0.28	5
		25	S 201 P-B 25 NA	2CDS 281 103 R0255	590020		0.28	5
		32	S 201 P-B 32 NA	2CDS 281 103 R0325	590037		0.28	5
		40	S 201 P-B 40 NA	2CDS 281 103 R0405	590044		0.28	5
		50	S 201 P-B 50 NA	2CDS 281 103 R0505	590051		0.28	5
		63	S 201 P-B 63 NA	2CDS 281 103 R0635	590068		0.28	5
3	6	S 203 P-B 6 NA	2CDS 283 103 R0065	590075		0.56	1	
	10	S 203 P-B 10 NA	2CDS 283 103 R0105	590082		0.56	1	
	NA	13	S 203 P-B 13 NA	2CDS 283 103 R0135	590099		0.56	1
		16	S 203 P-B 16 NA	2CDS 283 103 R0165	590105		0.56	1
		20	S 203 P-B 20 NA	2CDS 283 103 R0205	590112		0.56	1
		25	S 203 P-B 25 NA	2CDS 283 103 R0255	590129		0.56	1
		32	S 203 P-B 32 NA	2CDS 283 103 R0325	590136		0.56	1
		40	S 203 P-B 40 NA	2CDS 283 103 R0405	590143		0.56	1
		50	S 203 P-B 50 NA	2CDS 283 103 R0505	590150		0.56	1
		63	S 203 P-B 63 NA	2CDS 283 103 R0635	590167		0.56	1

2

C

2



2CSC400066F0201



2CSC400067F0201



2CSC400068F0201



S 200 P-C characteristic

Function: protection and control of the circuits against overloads and short-circuits; protection for resistive and inductive loads with low inrush current.

Applications: commercial and industrial.

Standard: IEC/EN 60898

I_{cn}=25 kA for 0.5 A ≤ I_n ≤ 25 A

I_{cn}=15 kA for 32 A ≤ I_n ≤ 63 A

Number of poles	Rated current	Order details	Bbn 4016779	Price 1 piece	Price group	Weight 1 piece	Pack unit
	In A	Type code	Order code	EAN		kg	pc.
1	0.5	S 201 P-C 0.5	2CDS 281 001 R0984	590174		0.14	10
	1	S 201 P-C 1	2CDS 281 001 R0014	590181		0.14	10
	1.6	S 201 P-C 1.6	2CDS 281 001 R0974	590198		0.14	10
	2	S 201 P-C 2	2CDS 281 001 R0024	590204		0.14	10
	3	S 201 P-C 3	2CDS 281 001 R0034	590211		0.14	10
	4	S 201 P-C 4	2CDS 281 001 R0044	590228		0.14	10
	6	S 201 P-C 6	2CDS 281 001 R0064	590235		0.14	10
	8	S 201 P-C 8	2CDS 281 001 R0084	590242		0.14	10
	10	S 201 P-C 10	2CDS 281 001 R0104	590259		0.14	10
	13	S 201 P-C 13	2CDS 281 001 R0134	590266		0.14	10
	16	S 201 P-C 16	2CDS 281 001 R0164	590273		0.14	10
	20	S 201 P-C 20	2CDS 281 001 R0204	590280		0.14	10
	25	S 201 P-C 25	2CDS 281 001 R0254	590297		0.14	10
	32	S 201 P-C 32	2CDS 281 001 R0324	590303		0.14	10
	40	S 201 P-C 40	2CDS 281 001 R0404	590310		0.14	10
	50	S 201 P-C 50	2CDS 281 001 R0504	590327		0.14	10
63	S 201 P-C 63	2CDS 281 001 R0634	590334		0.14	10	
2	0.5	S 202 P-C 0.5	2CDS 282 001 R0984	590341		0.28	5
	1	S 202 P-C 1	2CDS 282 001 R0014	590358		0.28	5
	1.6	S 202 P-C 1.6	2CDS 282 001 R0974	590365		0.28	5
	2	S 202 P-C 2	2CDS 282 001 R0024	590372		0.28	5
	3	S 202 P-C 3	2CDS 282 001 R0034	590389		0.28	5
	4	S 202 P-C 4	2CDS 282 001 R0044	590396		0.28	5
	6	S 202 P-C 6	2CDS 282 001 R0064	590402		0.28	5
	8	S 202 P-C 8	2CDS 282 001 R0084	590419		0.28	5
	10	S 202 P-C 10	2CDS 282 001 R0104	590426		0.28	5
	13	S 202 P-C 13	2CDS 282 001 R0134	590433		0.28	5
	16	S 202 P-C 16	2CDS 282 001 R0164	590440		0.28	5
	20	S 202 P-C 20	2CDS 282 001 R0204	590457		0.28	5
	25	S 202 P-C 25	2CDS 282 001 R0254	590464		0.28	5
	32	S 202 P-C 32	2CDS 282 001 R0324	590471		0.28	5
	40	S 202 P-C 40	2CDS 282 001 R0404	590488		0.28	5
	50	S 202 P-C 50	2CDS 282 001 R0504	590495		0.28	5
63	S 202 P-C 63	2CDS 282 001 R0634	590501		0.28	5	
3	0.5	S 203 P-C 0.5	2CDS 283 001 R0984	590518		0.42	1
	1	S 203 P-C 1	2CDS 283 001 R0014	590525		0.42	1
	1.6	S 203 P-C 1.6	2CDS 283 001 R0974	590532		0.42	1
	2	S 203 P-C 2	2CDS 283 001 R0024	590549		0.42	1
	3	S 203 P-C 3	2CDS 283 001 R0034	590556		0.42	1
	4	S 203 P-C 4	2CDS 283 001 R0044	590563		0.42	1
	6	S 203 P-C 6	2CDS 283 001 R0064	590570		0.42	1
	8	S 203 P-C 8	2CDS 283 001 R0084	590587		0.42	1
	10	S 203 P-C 10	2CDS 283 001 R0104	590594		0.42	1
	13	S 203 P-C 13	2CDS 283 001 R0134	590600		0.42	1
	16	S 203 P-C 16	2CDS 283 001 R0164	590617		0.42	1
	20	S 203 P-C 20	2CDS 283 001 R0204	590624		0.42	1
	25	S 203 P-C 25	2CDS 283 001 R0254	590631		0.42	1
	32	S 203 P-C 32	2CDS 283 001 R0324	590648		0.42	1
	40	S 203 P-C 40	2CDS 283 001 R0404	590655		0.42	1
	50	S 203 P-C 50	2CDS 283 001 R0504	590662		0.42	1
63	S 203 P-C 63	2CDS 283 001 R0634	590679		0.42	1	

U_{Bmax}
253 V ~
72 V ∴

U_{Bmax}
440 V ~
125 V ∴
④

U_{Bmax}
440 V ~

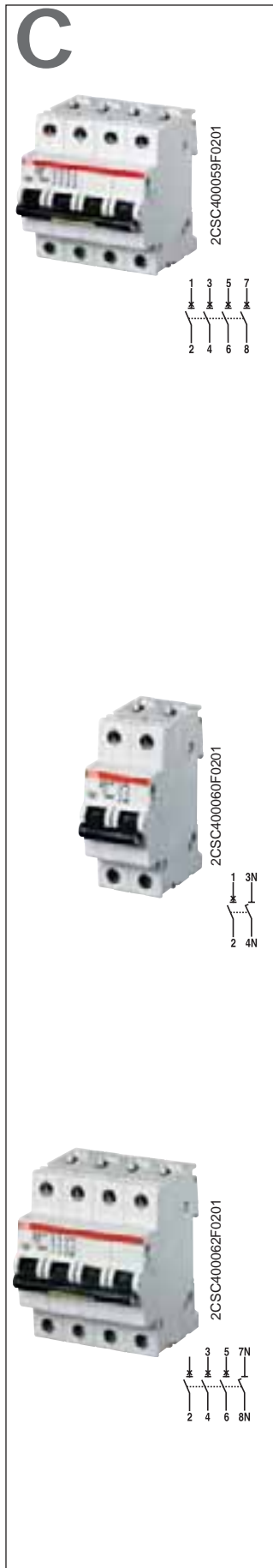

4	0.5	S 204 P-C 0.5	2CDS 284 001 R0984	590686	0.56	1
	1	S 204 P-C 1	2CDS 284 001 R0014	590693	0.56	1
	1.6	S 204 P-C 1.6	2CDS 284 001 R0974	590709	0.56	1
	2	S 204 P-C 2	2CDS 284 001 R0024	590716	0.56	1
	3	S 204 P-C 3	2CDS 284 001 R0034	590723	0.56	1
	4	S 204 P-C 4	2CDS 284 001 R0044	590730	0.56	1
	6	S 204 P-C 6	2CDS 284 001 R0064	590747	0.56	1
	8	S 204 P-C 8	2CDS 284 001 R0084	590754	0.56	1
	10	S 204 P-C 10	2CDS 284 001 R0104	590761	0.56	1
	13	S 204 P-C 13	2CDS 284 001 R0134	590778	0.56	1
	16	S 204 P-C 16	2CDS 284 001 R0164	590785	0.56	1
	20	S 204 P-C 20	2CDS 284 001 R0204	590792	0.56	1
	25	S 204 P-C 25	2CDS 284 001 R0254	590808	0.56	1
	32	S 204 P-C 32	2CDS 284 001 R0324	590815	0.56	1
	40	S 204 P-C 40	2CDS 284 001 R0404	590822	0.56	1
	50	S 204 P-C 50	2CDS 284 001 R0504	590839	0.56	1
④	63	S 204 P-C 63	2CDS 284 001 R0634	590846	0.56	1

U_{Bmax}
440 V ~
125 V ...

- ① suitable for flow-type heaters 12 kW
- ② suitable for flow-type heaters 18 kW
- ③ suitable for flow-type heaters 21, 24 and 27 kW
- ④ U_{Bmax} 125 V ... with 2 poles connected in series

With disconnecting neutral NA

Number of poles	Rated current	Order details	Bbn 4016779	Price 1 piece	Price group	Weight 1 piece	Pack unit
	In A	Type code	Order code	EAN		kg	pc.
1 + NA	0.5	S 201 P-C 0.5 NA	2CDS 281 103 R0984	590853		0.28	5
	1	S 201 P-C 1 NA	2CDS 281 103 R0014	590860		0.28	5
	1.6	S 201 P-C 1.6 NA	2CDS 281 103 R0974	590877		0.28	5
	2	S 201 P-C 2 NA	2CDS 281 103 R0024	590884		0.28	5
	3	S 201 P-C 3 NA	2CDS 281 103 R0034	590891		0.28	5
	4	S 201 P-C 4 NA	2CDS 281 103 R0044	590907		0.28	5
	6	S 201 P-C 6 NA	2CDS 281 103 R0064	590914		0.28	5
	8	S 201 P-C 8 NA	2CDS 281 103 R0084	590921		0.28	5
	10	S 201 P-C 10 NA	2CDS 281 103 R0104	590938		0.28	5
	13	S 201 P-C 13 NA	2CDS 281 103 R0134	590945		0.28	5
	16	S 201 P-C 16 NA	2CDS 281 103 R0164	590952		0.28	5
	20	S 201 P-C 20 NA	2CDS 281 103 R0204	590969		0.28	5
	25	S 201 P-C 25 NA	2CDS 281 103 R0254	590976		0.28	5
	32	S 201 P-C 32 NA	2CDS 281 103 R0324	590983		0.28	5
	40	S 201 P-C 40 NA	2CDS 281 103 R0404	590990		0.28	5
	50	S 201 P-C 50 NA	2CDS 281 103 R0504	591003		0.28	5
63	S 201 P-C 63 NA	2CDS 281 103 R0634	591010		0.28	5	
U _{Bmax} 253 V ~ 72 V ...							
3 + NA	0.5	S 203 P-C 0.5 NA	2CDS 283 103 R0984	591027		0.56	1
	1	S 203 P-C 1 NA	2CDS 283 103 R0014	591034		0.56	1
	1.6	S 203 P-C 1.6 NA	2CDS 283 103 R0974	591041		0.56	1
	2	S 203 P-C 2 NA	2CDS 283 103 R0024	591058		0.56	1
	3	S 203 P-C 3 NA	2CDS 283 103 R0034	591065		0.56	1
	4	S 203 P-C 4 NA	2CDS 283 103 R0044	591072		0.56	1
	6	S 203 P-C 6 NA	2CDS 283 103 R0064	591089		0.56	1
	8	S 203 P-C 8 NA	2CDS 283 103 R0084	591096		0.56	1
	10	S 203 P-C 10 NA	2CDS 283 103 R0104	591102		0.56	1
	13	S 203 P-C 13 NA	2CDS 283 103 R0134	591119		0.56	1
	16	S 203 P-C 16 NA	2CDS 283 103 R0164	591126		0.56	1
	20	S 203 P-C 20 NA	2CDS 283 103 R0204	591133		0.56	1
	25	S 203 P-C 25 NA	2CDS 283 103 R0254	591140		0.56	1
	32	S 203 P-C 32 NA	2CDS 283 103 R0324	591157		0.56	1
	40	S 203 P-C 40 NA	2CDS 283 103 R0404	591164		0.56	1
	50	S 203 P-C 50 NA	2CDS 283 103 R0504	591171		0.56	1
63	S 203 P-C 63 NA	2CDS 283 103 R0634	591188		0.56	1	
U _{Bmax} 440 V ~							

D

S 200 P-D characteristic

Function: protection and control of the circuits against overloads and short-circuits; protection for circuits which supply loads with high inrush current at the circuit closing (LV/LV transformers, breakdown lamps).

Applications: commercial and industrial.

Standard: IEC/EN 60898

I_{cn}=25 kA for 0.5 A ≤ I_n ≤ 25 A

I_{cn}=15 kA for 32 A ≤ I_n ≤ 63 A



2CSC400056F0201



2CSC400057F0201



2CSC400058F0201



Number of poles	Rated current	Order details	Bbn 4016779	Price 1 piece	Price group	Weight 1 piece	Pack unit
	I _n A	Type code	Order code	EAN		kg	pc.
1	0.5	S 201 P-D 0.5	2CDS 281 001 R0981	591195		0.14	10
	1	S 201 P-D 1	2CDS 281 001 R0011	591201		0.14	10
	1.6	S 201 P-D 1.6	2CDS 281 001 R0971	591218		0.14	10
	2	S 201 P-D 2	2CDS 281 001 R0021	591225		0.14	10
	3	S 201 P-D 3	2CDS 281 001 R0031	591232		0.14	10
	4	S 201 P-D 4	2CDS 281 001 R0041	591249		0.14	10
	6	S 201 P-D 6	2CDS 281 001 R0061	591256		0.14	10
	8	S 201 P-D 8	2CDS 281 001 R0081	591263		0.14	10
	10	S 201 P-D 10	2CDS 281 001 R0101	591270		0.14	10
	13	S 201 P-D 13	2CDS 281 001 R0131	591287		0.14	10
	16	S 201 P-D 16	2CDS 281 001 R0161	591294		0.14	10
	20	S 201 P-D 20	2CDS 281 001 R0201	591300		0.14	10
	25	S 201 P-D 25	2CDS 281 001 R0251	591317		0.14	10
	32	S 201 P-D 32	2CDS 281 001 R0321	591324		0.14	10
	40	S 201 P-D 40	2CDS 281 001 R0401	591331		0.14	10
	50	S 201 P-D 50	2CDS 281 001 R0501	591348		0.14	10
	63	S 201 P-D 63	2CDS 281 001 R0631	591355		0.14	10
U _{Bmax} 253 V ~ 72 V ...							
2	0.5	S 202 P-D 0.5	2CDS 282 001 R0981	591362		0.28	5
	1	S 202 P-D 1	2CDS 282 001 R0011	591379		0.28	5
	1.6	S 202 P-D 1.6	2CDS 282 001 R0971	591386		0.28	5
	2	S 202 P-D 2	2CDS 282 001 R0021	591393		0.28	5
	3	S 202 P-D 3	2CDS 282 001 R0031	591409		0.28	5
	4	S 202 P-D 4	2CDS 282 001 R0041	591416		0.28	5
	6	S 202 P-D 6	2CDS 282 001 R0061	591423		0.28	5
	8	S 202 P-D 8	2CDS 282 001 R0081	591430		0.28	5
	10	S 202 P-D 10	2CDS 282 001 R0101	591447		0.28	5
	13	S 202 P-D 13	2CDS 282 001 R0131	591454		0.28	5
	16	S 202 P-D 16	2CDS 282 001 R0161	591461		0.28	5
	20	S 202 P-D 20	2CDS 282 001 R0201	591478		0.28	5
	25	S 202 P-D 25	2CDS 282 001 R0251	591485		0.28	5
	32	S 202 P-D 32	2CDS 282 001 R0321	591492		0.28	5
	40	S 202 P-D 40	2CDS 282 001 R0401	591508		0.28	5
	50	S 202 P-D 50	2CDS 282 001 R0501	591515		0.28	5
	63	S 202 P-D 63	2CDS 282 001 R0631	591522		0.28	5
U _{Bmax} 440 V ~ 125 V ... ④							
3	0.5	S 203 P-D 0.5	2CDS 283 001 R0981	591539		0.42	1
	1	S 203 P-D 1	2CDS 283 001 R0011	591546		0.42	1
	1.6	S 203 P-D 1.6	2CDS 283 001 R0971	591553		0.42	1
	2	S 203 P-D 2	2CDS 283 001 R0021	591560		0.42	1
	3	S 203 P-D 3	2CDS 283 001 R0031	591577		0.42	1
	4	S 203 P-D 4	2CDS 283 001 R0041	591584		0.42	1
	6	S 203 P-D 6	2CDS 283 001 R0061	591591		0.42	1
	8	S 203 P-D 8	2CDS 283 001 R0081	591607		0.42	1
	10	S 203 P-D 10	2CDS 283 001 R0101	591614		0.42	1
	13	S 203 P-D 13	2CDS 283 001 R0131	591621		0.42	1
	16	S 203 P-D 16	2CDS 283 001 R0161	591638		0.42	1
	20	S 203 P-D 20	2CDS 283 001 R0201	591645		0.42	1
	25	S 203 P-D 25	2CDS 283 001 R0251	591652		0.42	1
	32	S 203 P-D 32	2CDS 283 001 R0321	591669		0.42	1
	40	S 203 P-D 40	2CDS 283 001 R0401	591676		0.42	1
	50	S 203 P-D 50	2CDS 283 001 R0501	591683		0.42	1
	63	S 203 P-D 63	2CDS 283 001 R0631	591690		0.42	1
U _{Bmax} 440 V ~							

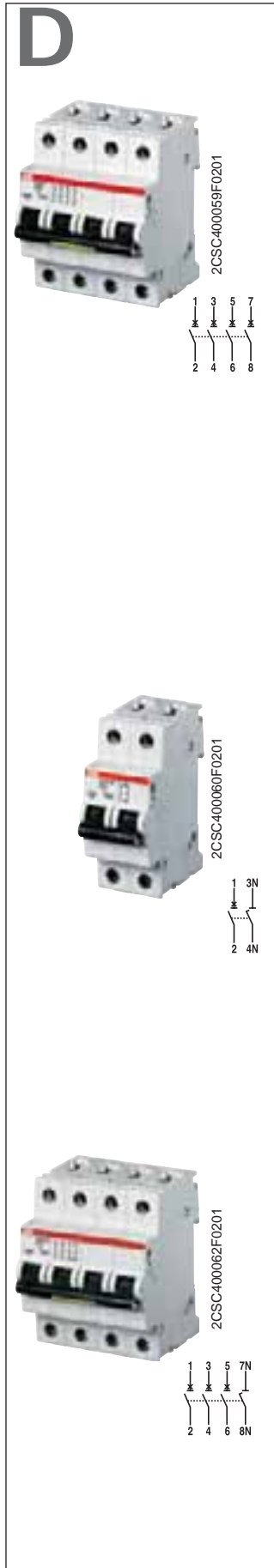

Number of poles	Rated current In A	Order details	Order code	EAN	Weight 1 piece	Pack unit
4	0.5	S 204 P-D 0.5	2CDS 284 001 R0981	591706	0.56	1
	1	S 204 P-D 1	2CDS 284 001 R0011	591713	0.56	1
	1.6	S 204 P-D 1.6	2CDS 284 001 R0971	591720	0.56	1
	2	S 204 P-D 2	2CDS 284 001 R0021	591737	0.56	1
	3	S 204 P-D 3	2CDS 284 001 R0031	591744	0.56	1
	4	S 204 P-D 4	2CDS 284 001 R0041	591751	0.56	1
	6	S 204 P-D 6	2CDS 284 001 R0061	591768	0.56	1
	8	S 204 P-D 8	2CDS 284 001 R0081	591775	0.56	1
	10	S 204 P-D 10	2CDS 284 001 R0101	591782	0.56	1
	13	S 204 P-D 13	2CDS 284 001 R0131	591799	0.56	1
	16	S 204 P-D 16	2CDS 284 001 R0161	591805	0.56	1
	20	S 204 P-D 20	2CDS 284 001 R0201	591812	0.56	1
	25	S 204 P-D 25	2CDS 284 001 R0251	591829	0.56	1
	32	S 204 P-D 32	2CDS 284 001 R0321	591836	0.56	1
	40	S 204 P-D 40	2CDS 284 001 R0401	591843	0.56	1
	50	S 204 P-D 50	2CDS 284 001 R0501	591850	0.56	1
④ 63	S 204 P-D 63	2CDS 284 001 R0631	591867	0.56	1	

U_{Bmax} 440 V ~
125 V ∴

- ① suitable for flow-type heaters 12 kW
- ② suitable for flow-type heaters 18 kW
- ③ suitable for flow-type heaters 21, 24 and 27 kW
- ④ U_{Bmax} 125 V ∴ with 2 poles connected in series

With disconnecting neutral NA

Number of poles	Rated current In A	Order details	Order code	EAN	Price 1 piece	Price group	Weight 1 piece	Pack unit
1 + NA	0.5	S 201 P-D 0.5 NA	2CDS 281 103 R0981	591874			0.28	5
	1	S 201 P-D 1 NA	2CDS 281 103 R0011	591881			0.28	5
	1.6	S 201 P-D 1.6 NA	2CDS 281 103 R0971	591898			0.28	5
	2	S 201 P-D 2 NA	2CDS 281 103 R0021	591904			0.28	5
	3	S 201 P-D 3 NA	2CDS 281 103 R0031	591911			0.28	5
	4	S 201 P-D 4 NA	2CDS 281 103 R0041	591928			0.28	5
	6	S 201 P-D 6 NA	2CDS 281 103 R0061	591935			0.28	5
	8	S 201 P-D 8 NA	2CDS 281 103 R0081	591942			0.28	5
	10	S 201 P-D 10 NA	2CDS 281 103 R0101	591959			0.28	5
	13	S 201 P-D 13 NA	2CDS 281 103 R0131	591966			0.28	5
	16	S 201 P-D 16 NA	2CDS 281 103 R0161	591973			0.28	5
	20	S 201 P-D 20 NA	2CDS 281 103 R0201	591980			0.28	5
	25	S 201 P-D 25 NA	2CDS 281 103 R0251	591997			0.28	5
	32	S 201 P-D 32 NA	2CDS 281 103 R0321	592000			0.28	5
	40	S 201 P-D 40 NA	2CDS 281 103 R0401	592017			0.28	5
	50	S 201 P-D 50 NA	2CDS 281 103 R0501	592024			0.28	5
63	S 201 P-D 63 NA	2CDS 281 103 R0631	592031			0.28	5	

U_{Bmax} 253 V ~
72 V ∴

Number of poles	Rated current In A	Order details	Order code	EAN	Price 1 piece	Price group	Weight 1 piece	Pack unit
3 + NA	0.5	S 203 P-D 0.5 NA	2CDS 283 103 R0981	592048			0.56	1
	1	S 203 P-D 1 NA	2CDS 283 103 R0011	592055			0.56	1
	1.6	S 203 P-D 1.6 NA	2CDS 283 103 R0971	592062			0.56	1
	2	S 203 P-D 2 NA	2CDS 283 103 R0021	592079			0.56	1
	3	S 203 P-D 3 NA	2CDS 283 103 R0031	592086			0.56	1
	4	S 203 P-D 4 NA	2CDS 283 103 R0041	592093			0.56	1
	6	S 203 P-D 6 NA	2CDS 283 103 R0061	592109			0.56	1
	8	S 203 P-D 8 NA	2CDS 283 103 R0081	592116			0.56	1
	10	S 203 P-D 10 NA	2CDS 283 103 R0101	592123			0.56	1
	13	S 203 P-D 13 NA	2CDS 283 103 R0131	592130			0.56	1
	16	S 203 P-D 16 NA	2CDS 283 103 R0161	592147			0.56	1
	20	S 203 P-D 20 NA	2CDS 283 103 R0201	592154			0.56	1
	25	S 203 P-D 25 NA	2CDS 283 103 R0251	592161			0.56	1
	32	S 203 P-D 32 NA	2CDS 283 103 R0321	592178			0.56	1
	40	S 203 P-D 40 NA	2CDS 283 103 R0401	592185			0.56	1
	50	S 203 P-D 50 NA	2CDS 283 103 R0501	592192			0.56	1
63	S 203 P-D 63 NA	2CDS 283 103 R0631	592208			0.56	1	

U_{Bmax} 440 V ~

K

2



S 200 P-K characteristic

Function: protection and control of the circuits like motors, transformers and auxiliary circuits, against overloads and short-circuits.

Advantages: no nuisance tripping in the case of functional peak currents up to $8I_n$, depending on the series; through its highly sensitive thermostatic bimetal trip, the K-type characteristic offers protection to damageable elements in the overcurrent range; it also provides the best protection to cables and lines.

Applications: commercial and industrial.

Standard: IEC/EN 60947-2, VDE 0660 Part 101

$I_{cu}=25$ kA for $0.5 A \leq I_n \leq 25 A$; $I_{cu}=15$ kA for $32 A \leq I_n \leq 63 A$ (acc. to VDE 0660 Part 101)

Number of poles	Rated current	Order details	Bbn 4016779	Price 1 piece	Price group	Weight 1 piece	Pack unit
In A	Type code	Order code	EAN	kg	pc.		
1	0.2	S 201 P-K 0.2	2CDS 281 001 R0087	592215		0.14	10
	0.3	S 201 P-K 0.3	2CDS 281 001 R0117	592222		0.14	10
	0.5	S 201 P-K 0.5	2CDS 281 001 R0157	592239		0.14	10
	0.75	S 201 P-K 0.75	2CDS 281 001 R0187	592246		0.14	10
	1	S 201 P-K 1	2CDS 281 001 R0217	592253		0.14	10
	1.6	S 201 P-K 1.6	2CDS 281 001 R0257	592260		0.14	10
	2	S 201 P-K 2	2CDS 281 001 R0277	592277		0.14	10
	3	S 201 P-K 3	2CDS 281 001 R0317	592284		0.14	10
	4	S 201 P-K 4	2CDS 281 001 R0337	592291		0.14	10
	6	S 201 P-K 6	2CDS 281 001 R0377	592307		0.14	10
	8	S 201 P-K 8	2CDS 281 001 R0407	592314		0.14	10
	10	S 201 P-K 10	2CDS 281 001 R0427	592321		0.14	10
	13	S 201 P-K 13	2CDS 281 001 R0447	592338		0.14	10
	16	S 201 P-K 16	2CDS 281 001 R0467	592345		0.14	10
	20	S 201 P-K 20	2CDS 281 001 R0487	592352		0.14	10
	25	S 201 P-K 25	2CDS 281 001 R0517	592369		0.14	10
	32	S 201 P-K 32	2CDS 281 001 R0537	592376		0.14	10
	40	S 201 P-K 40	2CDS 281 001 R0557	592383		0.14	10
	50	S 201 P-K 50	2CDS 281 001 R0577	592390		0.14	10
63	S 201 P-K 63	2CDS 281 001 R0607	592406		0.14	10	
2	0.2	S 202 P-K 0.2	2CDS 282 001 R0087	592413		0.28	5
	0.3	S 202 P-K 0.3	2CDS 282 001 R0117	592420		0.28	5
	0.5	S 202 P-K 0.5	2CDS 282 001 R0157	592437		0.28	5
	0.75	S 202 P-K 0.75	2CDS 282 001 R0187	592444		0.28	5
	1	S 202 P-K 1	2CDS 282 001 R0217	592451		0.28	5
	1.6	S 202 P-K 1.6	2CDS 282 001 R0257	592468		0.28	5
	2	S 202 P-K 2	2CDS 282 001 R0277	592475		0.28	5
	3	S 202 P-K 3	2CDS 282 001 R0317	592482		0.28	5
	4	S 202 P-K 4	2CDS 282 001 R0337	592499		0.28	5
	6	S 202 P-K 6	2CDS 282 001 R0377	592505		0.28	5
	8	S 202 P-K 8	2CDS 282 001 R0407	592512		0.28	5
	10	S 202 P-K 10	2CDS 282 001 R0427	592529		0.28	5
	13	S 202 P-K 13	2CDS 282 001 R0447	592536		0.28	5
	16	S 202 P-K 16	2CDS 282 001 R0467	592543		0.28	5
	20	S 202 P-K 20	2CDS 282 001 R0487	592550		0.28	5
	25	S 202 P-K 25	2CDS 282 001 R0517	592567		0.28	5
	32	S 202 P-K 32	2CDS 282 001 R0537	592574		0.28	5
	40	S 202 P-K 40	2CDS 282 001 R0557	592581		0.28	5
	50	S 202 P-K 50	2CDS 282 001 R0577	592598		0.28	5
63	S 202 P-K 63	2CDS 282 001 R0607	592604		0.28	5	
3	0.2	S 203 P-K 0.2	2CDS 283 001 R0087	592611		0.42	1
	0.3	S 203 P-K 0.3	2CDS 283 001 R0117	592628		0.42	1
	0.5	S 203 P-K 0.5	2CDS 283 001 R0157	592635		0.42	1
	0.75	S 203 P-K 0.75	2CDS 283 001 R0187	592642		0.42	1
	1	S 203 P-K 1	2CDS 283 001 R0217	592659		0.42	1
	1.6	S 203 P-K 1.6	2CDS 283 001 R0257	592666		0.42	1
	2	S 203 P-K 2	2CDS 283 001 R0277	592673		0.42	1
	3	S 203 P-K 3	2CDS 283 001 R0317	592680		0.42	1
	4	S 203 P-K 4	2CDS 283 001 R0337	592697		0.42	1
	6	S 203 P-K 6	2CDS 283 001 R0377	592703		0.42	1
	8	S 203 P-K 8	2CDS 283 001 R0407	592710		0.42	1
	10	S 203 P-K 10	2CDS 283 001 R0427	592727		0.42	1
	13	S 203 P-K 13	2CDS 283 001 R0447	592734		0.42	1
16	S 203 P-K 16	2CDS 283 001 R0467	592741		0.42	1	
20	S 203 P-K 20	2CDS 283 001 R0487	592758		0.42	1	

U_{Bmax}
253 V ~
72 V ∴

U_{Bmax}
440 V ~
125 V ∴

①

U_{Bmax}
440 V ~



25	S 203 P-K 25	2CDS 283 001 R0517	592765	0.42	1
32	S 203 P-K 32	2CDS 283 001 R0537	592772	0.42	1
40	S 203 P-K 40	2CDS 283 001 R0557	592789	0.42	1
50	S 203 P-K 50	2CDS 283 001 R0577	592796	0.42	1
63	S 203 P-K 63	2CDS 283 001 R0607	592802	0.42	1
<hr/>					
4	0.2 S 204 P-K 0.2	2CDS 284 001 R0087	592819	0.56	1
	0.3 S 204 P-K 0.3	2CDS 284 001 R0117	592826	0.56	1
	0.5 S 204 P-K 0.5	2CDS 284 001 R0157	592833	0.56	1
	0.75 S 204 P-K 0.75	2CDS 284 001 R0187	592840	0.56	1
	1 S 204 P-K 1	2CDS 284 001 R0217	592857	0.56	1
	1.6 S 204 P-K 1.6	2CDS 284 001 R0257	592864	0.56	1
	2 S 204 P-K 2	2CDS 284 001 R0277	592871	0.56	1
	3 S 204 P-K 3	2CDS 284 001 R0317	592888	0.56	1
	4 S 204 P-K 4	2CDS 284 001 R0337	592895	0.56	1
	6 S 204 P-K 6	2CDS 284 001 R0377	592901	0.56	1
	8 S 204 P-K 8	2CDS 284 001 R0407	592918	0.56	1
	10 S 204 P-K 10	2CDS 284 001 R0427	592925	0.56	1
	13 S 204 P-K 13	2CDS 284 001 R0447	592932	0.56	1
	16 S 204 P-K 16	2CDS 284 001 R0467	592949	0.56	1
	20 S 204 P-K 20	2CDS 284 001 R0487	592956	0.56	1
	25 S 204 P-K 25	2CDS 284 001 R0517	592963	0.56	1
	32 S 204 P-K 32	2CDS 284 001 R0537	592970	0.56	1
	40 S 204 P-K 40	2CDS 284 001 R0557	592987	0.56	1
	50 S 204 P-K 50	2CDS 284 001 R0577	592994	0.56	1
	63 S 204 P-K 63	2CDS 284 001 R0607	593007	0.56	1

U_{Bmax} 440 V ~
60 V ∴

① U_{Bmax} 125 V ∴ with 2 poles connected in series

With disconnecting neutral NA

Number of poles	Rated current	Order details	Bbn 4016779	Price 1 piece	Price group	Weight 1 piece	Pack unit
	In A	Type code	Order code	EAN		kg	pc.
1	0.2	S 201 P-K 0.2 NA	2CDS 281 103 R0087	593014		0.28	5
+	0.3	S 201 P-K 0.3 NA	2CDS 281 103 R0117	593021		0.28	5
NA	0.5	S 201 P-K 0.5 NA	2CDS 281 103 R0157	593038		0.28	5
	0.75	S 201 P-K 0.75 NA	2CDS 281 103 R0187	593045		0.28	5
	1	S 201 P-K 1 NA	2CDS 281 103 R0217	593052		0.28	5
	1.6	S 201 P-K 1.6 NA	2CDS 281 103 R0257	593069		0.28	5
	2	S 201 P-K 2 NA	2CDS 281 103 R0277	593076		0.28	5
	3	S 201 P-K 3 NA	2CDS 281 103 R0317	593083		0.28	5
	4	S 201 P-K 4 NA	2CDS 281 103 R0337	593090		0.28	5
	6	S 201 P-K 6 NA	2CDS 281 103 R0377	593106		0.28	5
	8	S 201 P-K 8 NA	2CDS 281 103 R0407	593113		0.28	5
	10	S 201 P-K 10 NA	2CDS 281 103 R0427	593120		0.28	5
	13	S 201 P-K 13 NA	2CDS 281 103 R0447	593137		0.28	5
	16	S 201 P-K 16 NA	2CDS 281 103 R0467	593144		0.28	5
	20	S 201 P-K 20 NA	2CDS 281 103 R0487	593151		0.28	5
	25	S 201 P-K 25 NA	2CDS 281 103 R0517	593168		0.28	5
	32	S 201 P-K 32 NA	2CDS 281 103 R0537	593175		0.28	5
	40	S 201 P-K 40 NA	2CDS 281 103 R0557	593182		0.28	5
	50	S 201 P-K 50 NA	2CDS 281 103 R0577	593199		0.28	5
	63	S 201 P-K 63 NA	2CDS 281 103 R0607	593205		0.28	5
<hr/>							
3	0.2	S 203 P-K 0.2 NA	2CDS 283 103 R0087	593212		0.56	2
+	0.3	S 203 P-K 0.3 NA	2CDS 283 103 R0117	593229		0.56	2
NA	0.5	S 203 P-K 0.5 NA	2CDS 283 103 R0157	593236		0.56	2
	0.75	S 203 P-K 0.75 NA	2CDS 283 103 R0187	593243		0.56	2
	1	S 203 P-K 1 NA	2CDS 283 103 R0217	593250		0.56	2
	1.6	S 203 P-K 1.6 NA	2CDS 283 103 R0257	593267		0.56	2
	2	S 203 P-K 2 NA	2CDS 283 103 R0277	593274		0.56	2
	3	S 203 P-K 3 NA	2CDS 283 103 R0317	593281		0.56	2
	4	S 203 P-K 4 NA	2CDS 283 103 R0337	593298		0.56	2
	6	S 203 P-K 6 NA	2CDS 283 103 R0377	593304		0.56	2
	8	S 203 P-K 8 NA	2CDS 283 103 R0407	593311		0.56	2
	10	S 203 P-K 10 NA	2CDS 283 103 R0427	593328		0.56	2
	13	S 203 P-K 13 NA	2CDS 283 103 R0447	593335		0.56	2
	16	S 203 P-K 16 NA	2CDS 283 103 R0467	593342		0.56	2
	20	S 203 P-K 20 NA	2CDS 283 103 R0487	593359		0.56	2
	25	S 203 P-K 25 NA	2CDS 283 103 R0517	593366		0.56	2
	32	S 203 P-K 32 NA	2CDS 283 103 R0537	593373		0.56	2
	40	S 203 P-K 40 NA	2CDS 283 103 R0557	593380		0.56	2
	50	S 203 P-K 50 NA	2CDS 283 103 R0577	593397		0.56	2
	63	S 203 P-K 63 NA	2CDS 283 103 R0607	593403		0.56	2

U_{Bmax} 253 V ~
72 V ∴

U_{Bmax} 440 V ~

Z

2



2CSC40002F0201



2CSC40004F0201



2CSC400128F0201



S 200 P-Z characteristic

Function: protection and control of the electronic circuits against weak and long duration overloads and short-circuits.

Applications: commercial and industrial.

Standard: IEC/EN 60947-2, VDE 0660 Part 101

I_{cu}=25 kA for 0.5 A ≤ I_n ≤ 25 A; I_{cu}=15 kA for 32 A ≤ I_n ≤ 63 A (acc. to VDE 0660 Part 101)

Number of poles	Rated current	Order details	Bbn 4016779	Price 1 piece	Price group	Weight 1 piece	Pack unit
	I _n A	Type code	Order code	EAN		kg	pc.
1	0.5	S 201 P-Z 0.5	2CDS 281 001 R0158	593410		0.14	10
	1	S 201 P-Z 1	2CDS 281 001 R0218	593427		0.14	10
	1.6	S 201 P-Z 1.6	2CDS 281 001 R0258	593434		0.14	10
	2	S 201 P-Z 2	2CDS 281 001 R0278	593441		0.14	10
	3	S 201 P-Z 3	2CDS 281 001 R0318	593458		0.14	10
	4	S 201 P-Z 4	2CDS 281 001 R0338	593465		0.14	10
	6	S 201 P-Z 6	2CDS 281 001 R0378	593472		0.14	10
	8	S 201 P-Z 8	2CDS 281 001 R0408	593489		0.14	10
	10	S 201 P-Z 10	2CDS 281 001 R0428	593496		0.14	10
	16	S 201 P-Z 16	2CDS 281 001 R0468	593502		0.14	10
	20	S 201 P-Z 20	2CDS 281 001 R0488	593519		0.14	10
	25	S 201 P-Z 25	2CDS 281 001 R0518	593526		0.14	10
	32	S 201 P-Z 32	2CDS 281 001 R0538	593533		0.14	10
	40	S 201 P-Z 40	2CDS 281 001 R0558	593540		0.14	10
50	S 201 P-Z 50	2CDS 281 001 R0578	593557		0.14	10	
63	S 201 P-Z 63	2CDS 281 001 R0608	593564		0.14	10	
2	0.5	S 202 P-Z 0.5	2CDS 282 001 R0158	593571		0.28	5
	1	S 202 P-Z 1	2CDS 282 001 R0218	593588		0.28	5
	1.6	S 202 P-Z 1.6	2CDS 282 001 R0258	593595		0.28	5
	2	S 202 P-Z 2	2CDS 282 001 R0278	593601		0.28	5
	3	S 202 P-Z 3	2CDS 282 001 R0318	593618		0.28	5
	4	S 202 P-Z 4	2CDS 282 001 R0338	593625		0.28	5
	6	S 202 P-Z 6	2CDS 282 001 R0378	593632		0.28	5
	8	S 202 P-Z 8	2CDS 282 001 R0408	593649		0.28	5
	10	S 202 P-Z 10	2CDS 282 001 R0428	593656		0.28	5
	16	S 202 P-Z 16	2CDS 282 001 R0468	593663		0.28	5
	20	S 202 P-Z 20	2CDS 282 001 R0488	593670		0.28	5
	25	S 202 P-Z 25	2CDS 282 001 R0518	593687		0.28	5
	32	S 202 P-Z 32	2CDS 282 001 R0538	593694		0.28	5
	40	S 202 P-Z 40	2CDS 282 001 R0558	593700		0.28	5
50	S 202 P-Z 50	2CDS 282 001 R0578	593717		0.28	5	
63	S 202 P-Z 63	2CDS 282 001 R0608	593724		0.28	5	
3	0.5	S 203 P-Z 0.5	2CDS 283 001 R0158	593731		0.42	1
	1	S 203 P-Z 1	2CDS 283 001 R0218	593748		0.42	1
	1.6	S 203 P-Z 1.6	2CDS 283 001 R0258	593755		0.42	1
	2	S 203 P-Z 2	2CDS 283 001 R0278	593762		0.42	1
	3	S 203 P-Z 3	2CDS 283 001 R0318	593779		0.42	1
	4	S 203 P-Z 4	2CDS 283 001 R0338	593786		0.42	1
	6	S 203 P-Z 6	2CDS 283 001 R0378	593793		0.42	1
	8	S 203 P-Z 8	2CDS 283 001 R0408	593809		0.42	1
	10	S 203 P-Z 10	2CDS 283 001 R0428	593816		0.42	1
	16	S 203 P-Z 16	2CDS 283 001 R0468	593823		0.42	1
	20	S 203 P-Z 20	2CDS 283 001 R0488	593830		0.42	1
	25	S 203 P-Z 25	2CDS 283 001 R0518	593847		0.42	1
	32	S 203 P-Z 32	2CDS 283 001 R0538	593854		0.42	1
	40	S 203 P-Z 40	2CDS 283 001 R0558	593861		0.42	1
50	S 203 P-Z 50	2CDS 283 001 R0578	593878		0.42	1	
63	S 203 P-Z 63	2CDS 283 001 R0608	593885		0.42	1	

U_{Bmax}
253 V ~
72 V ∴

U_{Bmax}
440 V ~
125 V ∴

①

U_{Bmax}
440 V ~



Number of poles	Rated current	Type code	Order code	EAN	Price 1 piece	Weight 1 piece	Pack unit
4	0.5	S 204 P-Z 0.5	2CDS 284 001 R0158	593892	0.56	1	
	1	S 204 P-Z 1	2CDS 284 001 R0218	593908	0.56	1	
	1.6	S 204 P-Z 1.6	2CDS 284 001 R0258	593915	0.56	1	
	2	S 204 P-Z 2	2CDS 284 001 R0278	593922	0.56	1	
	3	S 204 P-Z 3	2CDS 284 001 R0318	593939	0.56	1	
	4	S 204 P-Z 4	2CDS 284 001 R0338	593946	0.56	1	
	6	S 204 P-Z 6	2CDS 284 001 R0378	593953	0.56	1	
	8	S 204 P-Z 8	2CDS 284 001 R0408	593960	0.56	1	
	10	S 204 P-Z 10	2CDS 284 001 R0428	593977	0.56	1	
	16	S 204 P-Z 16	2CDS 284 001 R0468	593984	0.56	1	
	20	S 204 P-Z 20	2CDS 284 001 R0488	593991	0.56	1	
	25	S 204 P-Z 25	2CDS 284 001 R0518	594004	0.56	1	
	32	S 204 P-Z 32	2CDS 284 001 R0538	594011	0.56	1	
①	40	S 204 P-Z 40	2CDS 284 001 R0558	594028	0.56	1	
	50	S 204 P-Z 50	2CDS 284 001 R0578	594035	0.56	1	
	63	S 204 P-Z 63	2CDS 284 001 R0608	594042	0.56	1	

U_{Bmax}
440 V ~
125 V ∴

① U_{Bmax} 125 V ∴ with 2 poles connected in series

With disconnecting neutral NA

Number of poles	Rated current	Type code	Order code	EAN	Price 1 piece	Weight 1 piece	Pack unit
1	0.5	S 201 P-Z 0.5 NA	2CDS 281 103 R0158	594059	0.28	5	
	1	S 201 P-Z 1 NA	2CDS 281 103 R0218	594066	0.28	5	
	NA	1.6	S 201 P-Z 1.6 NA	2CDS 281 103 R0258	594073	0.28	5
		2	S 201 P-Z 2 NA	2CDS 281 103 R0278	594080	0.28	5
		3	S 201 P-Z 3 NA	2CDS 281 103 R0318	594097	0.28	5
		4	S 201 P-Z 4 NA	2CDS 281 103 R0338	594103	0.28	5
		6	S 201 P-Z 6 NA	2CDS 281 103 R0378	594110	0.28	5
		8	S 201 P-Z 8 NA	2CDS 281 103 R0408	594127	0.28	5
		10	S 201 P-Z 10 NA	2CDS 281 103 R0428	594134	0.28	5
		16	S 201 P-Z 16 NA	2CDS 281 103 R0468	594141	0.28	5
		20	S 201 P-Z 20 NA	2CDS 281 103 R0488	594158	0.28	5
		25	S 201 P-Z 25 NA	2CDS 281 103 R0518	594165	0.28	5
		32	S 201 P-Z 32 NA	2CDS 281 103 R0538	594172	0.28	5
U _{Bmax} 253 V ~ 72 V ∴	40	S 201 P-Z 40 NA	2CDS 281 103 R0558	594189	0.28	5	
	50	S 201 P-Z 50 NA	2CDS 281 103 R0578	594196	0.28	5	
	63	S 201 P-Z 63 NA	2CDS 281 103 R0608	594202	0.28	5	
3	0.5	S 203 P-Z 0.5 NA	2CDS 283 103 R0158	594219	0.56	1	
	1	S 203 P-Z 1 NA	2CDS 283 103 R0218	594226	0.56	1	
	NA	1.6	S 203 P-Z 1.6 NA	2CDS 283 103 R0258	594233	0.56	1
		2	S 203 P-Z 2 NA	2CDS 283 103 R0278	594240	0.56	1
		3	S 203 P-Z 3 NA	2CDS 283 103 R0318	594257	0.56	1
		4	S 203 P-Z 4 NA	2CDS 283 103 R0338	594264	0.56	1
		6	S 203 P-Z 6 NA	2CDS 283 103 R0378	594271	0.56	1
		8	S 203 P-Z 8 NA	2CDS 283 103 R0408	594288	0.56	1
		10	S 203 P-Z 10 NA	2CDS 283 103 R0428	594295	0.56	1
		16	S 203 P-Z 16 NA	2CDS 283 103 R0468	594301	0.56	1
		20	S 203 P-Z 20 NA	2CDS 283 103 R0488	594318	0.56	1
		25	S 203 P-Z 25 NA	2CDS 283 103 R0518	594325	0.56	1
		32	S 203 P-Z 32 NA	2CDS 283 103 R0538	594332	0.56	1
U _{Bmax} 440 V ~	40	S 203 P-Z 40 NA	2CDS 283 103 R0558	594349	0.56	1	
	50	S 203 P-Z 50 NA	2CDS 283 103 R0578	594356	0.56	1	
	63	S 203 P-Z 63 NA	2CDS 283 103 R0608	594363	0.56	1	

10000

K

S 200 U-K characteristic

Function: protection and control of the electronic circuits against weak and long duration overloads and short-circuits.

Applications: commercial and industrial.

Standard: IEC/EN 60947-2, UL 489, CSA 22.2 No. 5

Number of poles	Rated current	Order details	Bbn 4016779	Price 1 piece	Price group	Weight 1 piece	Pack unit
In A	Type code	Order code	EAN			kg	pc.
1	0.2	S 201 U-K 0.2	2CDS 271 417 R0087	619226		0.14	10
	0.3	S 201 U-K 0.3	2CDS 271 417 R0117	619233		0.14	10
	0.5	S 201 U-K 0.5	2CDS 271 417 R0157	619240		0.14	10
	0.75	S 201 U-K 0.75	2CDS 271 417 R0187	619257		0.14	10
	1	S 201 U-K 1	2CDS 271 417 R0217	619264		0.14	10
	1.6	S 201 U-K 1.6	2CDS 271 417 R0257	619271		0.14	10
	2	S 201 U-K 2	2CDS 271 417 R0277	619288		0.14	10
	3	S 201 U-K 3	2CDS 271 417 R0317	619295		0.14	10
	4	S 201 U-K 4	2CDS 271 417 R0337	619301		0.14	10
	5	S 201 U-K 5	2CDS 271 417 R0357	619318		0.14	10
	6	S 201 U-K 6	2CDS 271 417 R0377	619325		0.14	10
	8	S 201 U-K 8	2CDS 271 417 R0407	619332		0.14	10
	10	S 201 U-K 10	2CDS 271 417 R0427	619349		0.14	10
	13	S 201 U-K 13	2CDS 271 417 R0447	619356		0.14	10
	15	S 201 U-K 15	2CDS 271 417 R0457	619363		0.14	10
	16	S 201 U-K 16	2CDS 271 417 R0467	619370		0.14	10
	20	S 201 U-K 20	2CDS 271 417 R0487	619387		0.14	10
25	S 201 U-K 25	2CDS 271 417 R0517	619394		0.14	10	
30	S 201 U-K 30	2CDS 271 417 R0527	619400		0.14	10	
32	S 201 U-K 32	2CDS 271 417 R0537	619417		0.14	10	
40	S 201 U-K 40	2CDS 271 417 R0557	619424		0.14	10	
50	S 201 U-K 50	2CDS 271 417 R0577	619431		0.14	10	
60	S 201 U-K 60	2CDS 271 417 R0587	619448		0.14	10	
63	S 201 U-K 63	2CDS 271 417 R0607	619455		0.14	10	
2	0.2	S 202 U-K 0.2	2CDS 272 417 R0087	619462		0.28	5
	0.3	S 202 U-K 0.3	2CDS 272 417 R0117	619479		0.28	5
	0.5	S 202 U-K 0.5	2CDS 272 417 R0157	619486		0.28	5
	0.75	S 202 U-K 0.75	2CDS 272 417 R0187	619493		0.28	5
	1	S 202 U-K 1	2CDS 272 417 R0217	619509		0.28	5
	1.6	S 202 U-K 1.6	2CDS 272 417 R0257	619516		0.28	5
	2	S 202 U-K 2	2CDS 272 417 R0277	619523		0.28	5
	3	S 202 U-K 3	2CDS 272 417 R0317	619530		0.28	5
	4	S 202 U-K 4	2CDS 272 417 R0337	619547		0.28	5
	5	S 202 U-K 5	2CDS 272 417 R0357	619554		0.28	5
	6	S 202 U-K 6	2CDS 272 417 R0377	619561		0.28	5
	8	S 202 U-K 8	2CDS 272 417 R0407	619578		0.28	5
	10	S 202 U-K 10	2CDS 272 417 R0427	619585		0.28	5
	13	S 202 U-K 13	2CDS 272 417 R0447	619592		0.28	5
	15	S 202 U-K 15	2CDS 272 417 R0457	619608		0.28	5
	16	S 202 U-K 16	2CDS 272 417 R0467	619615		0.28	5
	20	S 202 U-K 20	2CDS 272 417 R0487	619622		0.28	5
25	S 202 U-K 25	2CDS 272 417 R0517	619639		0.28	5	
30	S 202 U-K 30	2CDS 272 417 R0527	619646		0.28	5	
32	S 202 U-K 32	2CDS 272 417 R0537	619653		0.28	5	
40	S 202 U-K 40	2CDS 272 417 R0557	619660		0.28	5	
50	S 202 U-K 50	2CDS 272 417 R0577	619677		0.28	5	
60	S 202 U-K 60	2CDS 272 417 R0587	619684		0.28	5	
63	S 202 U-K 63	2CDS 272 417 R0607	619691		0.28	5	



2CSC400014F0201



2CSC400015F0201



10000

2



3	0.2	S 203 U-K	0.2	2CDS 273 417 R0087	619707	0.42	3
	0.3	S 203 U-K	0.3	2CDS 273 417 R0117	619714	0.42	3
	0.5	S 203 U-K	0.5	2CDS 273 417 R0157	619721	0.42	3
	0.75	S 203 U-K	0.75	2CDS 273 417 R0187	619738	0.42	3
	1	S 203 U-K	1	2CDS 273 417 R0217	619745	0.42	3
	1.6	S 203 U-K	1.6	2CDS 273 417 R0257	619752	0.42	3
	2	S 203 U-K	2	2CDS 273 417 R0277	619769	0.42	3
	3	S 203 U-K	3	2CDS 273 417 R0317	619776	0.42	3
	4	S 203 U-K	4	2CDS 273 417 R0337	619783	0.42	3
	5	S 203 U-K	5	2CDS 273 417 R0357	619790	0.42	3
	6	S 203 U-K	6	2CDS 273 417 R0377	619806	0.42	3
	8	S 203 U-K	8	2CDS 273 417 R0407	619813	0.42	3
	10	S 203 U-K	10	2CDS 273 417 R0427	619820	0.42	3
	13	S 203 U-K	13	2CDS 273 417 R0447	619837	0.42	3
	15	S 203 U-K	15	2CDS 273 417 R0457	619844	0.42	3
	16	S 203 U-K	16	2CDS 273 417 R0467	619851	0.42	3
	20	S 203 U-K	20	2CDS 273 417 R0487	619868	0.42	3
	25	S 203 U-K	25	2CDS 273 417 R0517	619875	0.42	3
	30	S 203 U-K	30	2CDS 273 417 R0527	619882	0.42	3
	32	S 203 U-K	32	2CDS 273 417 R0537	619899	0.42	3
	40	S 203 U-K	40	2CDS 273 417 R0557	619905	0.42	3
	50	S 203 U-K	50	2CDS 273 417 R0577	619912	0.42	3
	60	S 203 U-K	60	2CDS 273 417 R0587	619929	0.42	3
	63	S 203 U-K	63	2CDS 273 417 R0607	619936	0.42	3

4	0.2	S 204 U-K	0.2	2CDS 274 417 R0087	619943	0.56	2
	0.3	S 204 U-K	0.3	2CDS 274 417 R0117	619479	0.56	2
	0.5	S 204 U-K	0.5	2CDS 274 417 R0157	619967	0.56	2
	0.75	S 204 U-K	0.75	2CDS 274 417 R0187	619974	0.56	2
	1	S 204 U-K	1	2CDS 274 417 R0217	619509	0.56	2
	1.6	S 204 U-K	1.6	2CDS 274 417 R0257	619998	0.56	2
	2	S 204 U-K	2	2CDS 274 417 R0277	620000	0.56	2
	3	S 204 U-K	3	2CDS 274 417 R0317	620017	0.56	2
	4	S 204 U-K	4	2CDS 274 417 R0337	620024	0.56	2
	5	S 204 U-K	5	2CDS 274 417 R0357	620031	0.56	2
	6	S 204 U-K	6	2CDS 274 417 R0377	620048	0.56	2
	8	S 204 U-K	8	2CDS 274 417 R0407	620055	0.56	2
	10	S 204 U-K	10	2CDS 274 417 R0427	620062	0.56	2
	13	S 204 U-K	13	2CDS 274 417 R0447	620079	0.56	2
	15	S 204 U-K	15	2CDS 274 417 R0457	620086	0.56	2
	16	S 204 U-K	16	2CDS 274 417 R0467	620093	0.56	2
	20	S 204 U-K	20	2CDS 274 417 R0487	620109	0.56	2
	25	S 204 U-K	25	2CDS 274 417 R0517	620116	0.56	2
	30	S 204 U-K	30	2CDS 274 417 R0527	620123	0.56	2
	32	S 204 U-K	32	2CDS 274 417 R0537	620130	0.56	2
	40	S 204 U-K	40	2CDS 274 417 R0557	620147	0.56	2
	50	S 204 U-K	50	2CDS 274 417 R0577	620154	0.56	2
	60	S 204 U-K	60	2CDS 274 417 R0587	620161	0.56	2
	63	S 204 U-K	63	2CDS 274 417 R0607	620178	0.56	2

Z

2



2CSC400014F0201



2CSC400015F0201



S 200 U-Z characteristic

Function: protection and control of the electronic circuits against weak and long duration overloads and short-circuits.

Applications: commercial and industrial.

Standard: IEC/EN 60947-2, UL 489, CSA 22.2 No. 5

Number of poles	Rated current	Order details		Bbn 4016779	Price 1 piece	Price group	Weight 1 piece	Pack unit
In A	Type code	Order code	EAN				kg	pc.
1	0.5	S 201 U-Z 0.5	2CDS 271 417 R0158	620185			0.14	10
	1	S 201 U-Z 1	2CDS 271 417 R0218	620192			0.14	10
	1.6	S 201 U-Z 1.6	2CDS 271 417 R0258	620208			0.14	10
	2	S 201 U-Z 2	2CDS 271 417 R0278	620215			0.14	10
	3	S 201 U-Z 3	2CDS 271 417 R0318	620222			0.14	10
	4	S 201 U-Z 4	2CDS 271 417 R0338	620239			0.14	10
	5	S 201 U-Z 5	2CDS 271 417 R0358	620246			0.14	10
	6	S 201 U-Z 6	2CDS 271 417 R0378	620253			0.14	10
	8	S 201 U-Z 8	2CDS 271 417 R0408	620260			0.14	10
	10	S 201 U-Z 10	2CDS 271 417 R0428	620277			0.14	10
	15	S 201 U-Z 15	2CDS 271 417 R0458	620291			0.14	10
	16	S 201 U-Z 16	2CDS 271 417 R0468	620307			0.14	10
	20	S 201 U-Z 20	2CDS 271 417 R0488	620314			0.14	10
	25	S 201 U-Z 25	2CDS 271 417 R0518	620321			0.14	10
	30	S 201 U-Z 30	2CDS 271 417 R0528	622851			0.14	10
	32	S 201 U-Z 32	2CDS 271 417 R0538	620345			0.14	10
	40	S 201 U-Z 40	2CDS 271 417 R0558	620352			0.14	10
50	S 201 U-Z 50	2CDS 271 417 R0578	620369			0.14	10	
60	S 201 U-Z 60	2CDS 271 417 R0588	620376			0.14	10	
63	S 201 U-Z 63	2CDS 271 417 R0608	620383			0.14	10	
2	0.5	S 202 U-Z 0.5	2CDS 272 417 R0158	620390			0.28	5
	1	S 202 U-Z 1	2CDS 272 417 R0218	620406			0.28	5
	1.6	S 202 U-Z 1.6	2CDS 272 417 R0258	620413			0.28	5
	2	S 202 U-Z 2	2CDS 272 417 R0278	620420			0.28	5
	3	S 202 U-Z 3	2CDS 272 417 R0318	620437			0.28	5
	4	S 202 U-Z 4	2CDS 272 417 R0338	620444			0.28	5
	5	S 202 U-Z 5	2CDS 272 417 R0358	620451			0.28	5
	6	S 202 U-Z 6	2CDS 272 417 R0378	620468			0.28	5
	8	S 202 U-Z 8	2CDS 272 417 R0408	620475			0.28	5
	10	S 202 U-Z 10	2CDS 272 417 R0428	620482			0.28	5
	15	S 202 U-Z 15	2CDS 272 417 R0458	620505			0.28	5
	16	S 202 U-Z 16	2CDS 272 417 R0468	620512			0.28	5
	20	S 202 U-Z 20	2CDS 272 417 R0488	620529			0.28	5
	25	S 202 U-Z 25	2CDS 272 417 R0518	620536			0.28	5
	30	S 202 U-Z 30	2CDS 272 417 R0528	620543			0.28	5
32	S 202 U-Z 32	2CDS 272 417 R0538	620550			0.28	5	
40	S 202 U-Z 40	2CDS 272 417 R0558	620567			0.28	5	
50	S 202 U-Z 50	2CDS 272 417 R0578	620574			0.28	5	
60	S 202 U-Z 60	2CDS 272 417 R0588	620581			0.28	5	
63	S 202 U-Z 63	2CDS 272 417 R0608	620598			0.28	5	



3	0.5	S 203 U-Z	0.5	2CDS 273 417 R0158	620604	0.42	3
	1	S 203 U-Z	1	2CDS 273 417 R0218	620611	0.42	3
	1.6	S 203 U-Z	1.6	2CDS 273 417 R0258	620628	0.42	3
	2	S 203 U-Z	2	2CDS 273 417 R0278	620635	0.42	3
	3	S 203 U-Z	3	2CDS 273 417 R0318	620624	0.42	3
	4	S 203 U-Z	4	2CDS 273 417 R0338	620659	0.42	3
	5	S 203 U-Z	5	2CDS 273 417 R0358	620666	0.42	3
	6	S 203 U-Z	6	2CDS 273 417 R0378	620673	0.42	3
	8	S 203 U-Z	8	2CDS 273 417 R0408	620680	0.42	3
	10	S 203 U-Z	10	2CDS 273 417 R0428	620697	0.42	3
	15	S 203 U-Z	15	2CDS 273 417 R0458	620710	0.42	3
	16	S 203 U-Z	16	2CDS 273 417 R0468	620727	0.42	3
	20	S 203 U-Z	20	2CDS 273 417 R0488	620734	0.42	3
	25	S 203 U-Z	25	2CDS 273 417 R0518	620741	0.42	3
	30	S 203 U-Z	30	2CDS 273 417 R0528	620758	0.42	3
	32	S 203 U-Z	32	2CDS 273 417 R0538	620765	0.42	3
	40	S 203 U-Z	40	2CDS 273 417 R0558	620772	0.42	3
	50	S 203 U-Z	50	2CDS 273 417 R0578	620789	0.42	3
	60	S 203 U-Z	60	2CDS 273 417 R0588	620796	0.42	3
	63	S 203 U-Z	63	2CDS 273 417 R0608	620802	0.42	3

4	0.5	S 204 U-Z	0.5	2CDS 274 417 R0158	620819	0.56	2
	1	S 204 U-Z	1	2CDS 274 417 R0218	620826	0.56	2
	1.6	S 204 U-Z	1.6	2CDS 274 417 R0258	620833	0.56	2
	2	S 204 U-Z	2	2CDS 274 417 R0278	620840	0.56	2
	3	S 204 U-Z	3	2CDS 274 417 R0318	620857	0.56	2
	4	S 204 U-Z	4	2CDS 274 417 R0338	620864	0.56	2
	5	S 204 U-Z	5	2CDS 274 417 R0358	620871	0.56	2
	6	S 204 U-Z	6	2CDS 274 417 R0378	620888	0.56	2
	8	S 204 U-Z	8	2CDS 274 417 R0408	620895	0.56	2
	10	S 204 U-Z	10	2CDS 274 417 R0428	620901	0.56	2
	15	S 204 U-Z	15	2CDS 274 417 R0458	620925	0.56	2
	16	S 204 U-Z	16	2CDS 274 417 R0468	620932	0.56	2
	20	S 204 U-Z	20	2CDS 274 417 R0488	620949	0.56	2
	25	S 204 U-Z	25	2CDS 274 417 R0518	620956	0.56	2
	30	S 204 U-Z	30	2CDS 274 417 R0528	620963	0.56	2
	32	S 204 U-Z	32	2CDS 274 417 R0538	620970	0.56	2
	40	S 204 U-Z	40	2CDS 274 417 R0558	620987	0.56	2
	50	S 204 U-Z	50	2CDS 274 417 R0578	620994	0.56	2
	60	S 204 U-Z	60	2CDS 274 417 R0588	621007	0.56	2
	63	S 204 U-Z	63	2CDS 274 417 R0608	621014	0.56	2

K



2CSC400018F0201



2CSC400019F0201



S 200 UP-K characteristic

Function: protection and control of the electronic circuits against weak and long duration overloads and short-circuits.

Applications: commercial and industrial.

Standard: IEC/EN 60947-2, UL 489, CSA 22.2 No. 5

Number of poles	Rated current	Order details	Bbn 4016779	Price 1 piece	Price group	Weight 1 piece	Pack unit
In A	Type code	Order code	EAN			kg	pc.
1	0.2	S 201 UP-K 0.2	2CDS 271 317 R0087	615631		0.14	10
	0.3	S 201 UP-K 0.3	2CDS 271 317 R0117	615648		0.14	10
	0.5	S 201 UP-K 0.5	2CDS 271 317 R0157	615655		0.14	10
	0.75	S 201 UP-K 0.75	2CDS 271 317 R0187	615662		0.14	10
	1	S 201 UP-K 1	2CDS 271 317 R0217	615679		0.14	10
	1.6	S 201 UP-K 1.6	2CDS 271 317 R0257	615686		0.14	10
	2	S 201 UP-K 2	2CDS 271 317 R0277	615693		0.14	10
	3	S 201 UP-K 3	2CDS 271 317 R0317	615709		0.14	10
	4	S 201 UP-K 4	2CDS 271 317 R0337	615716		0.14	10
	5	S 201 UP-K 5	2CDS 271 317 R0357	615723		0.14	10
	6	S 201 UP-K 6	2CDS 271 317 R0377	615730		0.14	10
	8	S 201 UP-K 8	2CDS 271 317 R0407	615747		0.14	10
	10	S 201 UP-K 10	2CDS 271 317 R0427	615754		0.14	10
	13	S 201 UP-K 13	2CDS 271 317 R0447	615761		0.14	10
	15	S 201 UP-K 15	2CDS 271 317 R0457	615778		0.14	10
16	S 201 UP-K 16	2CDS 271 317 R0467	615785		0.14	10	
20	S 201 UP-K 20	2CDS 271 317 R0487	615792		0.14	10	
25	S 201 UP-K 25	2CDS 271 317 R0517	615808		0.14	10	
2	0.2	S 202 UP-K 0.2	2CDS 272 317 R0087	615877		0.28	5
	0.3	S 202 UP-K 0.3	2CDS 272 317 R0117	615884		0.28	5
	0.5	S 202 UP-K 0.5	2CDS 272 317 R0157	615891		0.28	5
	0.75	S 202 UP-K 0.75	2CDS 272 317 R0187	615907		0.28	5
	1	S 202 UP-K 1	2CDS 272 317 R0217	615914		0.28	5
	1.6	S 202 UP-K 1.6	2CDS 272 317 R0257	615921		0.28	5
	2	S 202 UP-K 2	2CDS 272 317 R0277	615938		0.28	5
	3	S 202 UP-K 3	2CDS 272 317 R0317	615945		0.28	5
	4	S 202 UP-K 4	2CDS 272 317 R0337	615952		0.28	5
	5	S 202 UP-K 5	2CDS 272 317 R0357	615969		0.28	5
	6	S 202 UP-K 6	2CDS 272 317 R0377	615976		0.28	5
	8	S 202 UP-K 8	2CDS 272 317 R0407	615983		0.28	5
	10	S 202 UP-K 10	2CDS 272 317 R0427	615990		0.28	5
	13	S 202 UP-K 13	2CDS 272 317 R0447	616003		0.28	5
	15	S 202 UP-K 15	2CDS 272 317 R0457	616010		0.28	5
16	S 202 UP-K 16	2CDS 272 317 R0467	616027		0.28	5	
20	S 202 UP-K 20	2CDS 272 317 R0487	616034		0.28	5	
25	S 202 UP-K 25	2CDS 272 317 R0517	616041		0.28	5	

10000

2

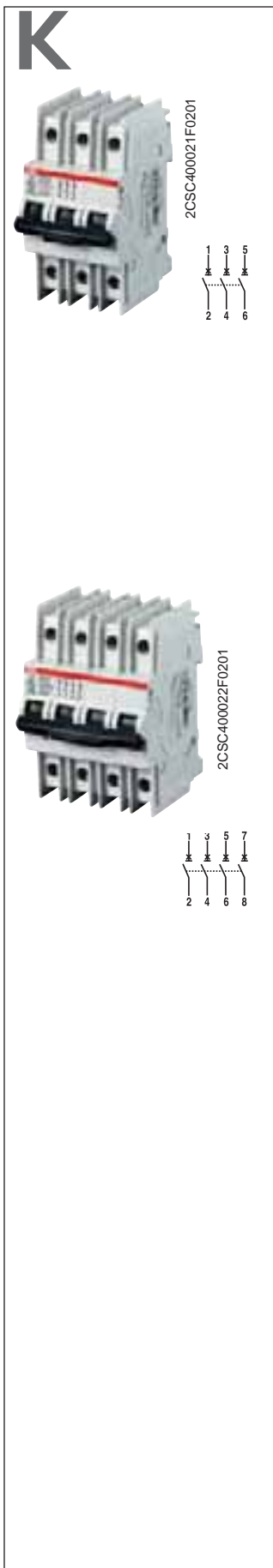

3	0.2	S 203 UP-K	0.2	2CDS 273 317 R0087	616119	0.42	3
	0.3	S 203 UP-K	0.3	2CDS 273 317 R0117	616126	0.42	3
	0.5	S 203 UP-K	0.5	2CDS 273 317 R0157	616133	0.42	3
	0.75	S 203 UP-K	0.75	2CDS 273 317 R0187	616140	0.42	3
	1	S 203 UP-K	1	2CDS 273 317 R0217	616157	0.42	3
	1.6	S 203 UP-K	1.6	2CDS 273 317 R0257	616164	0.42	3
	2	S 203 UP-K	2	2CDS 273 317 R0277	616171	0.42	3
	3	S 203 UP-K	3	2CDS 273 317 R0317	616188	0.42	3
	4	S 203 UP-K	4	2CDS 273 317 R0337	616195	0.42	3
	5	S 203 UP-K	5	2CDS 273 317 R0357	616201	0.42	3
	6	S 203 UP-K	6	2CDS 273 317 R0377	616218	0.42	3
	8	S 203 UP-K	8	2CDS 273 317 R0407	616225	0.42	3
	10	S 203 UP-K	10	2CDS 273 317 R0427	616232	0.42	3
	13	S 203 UP-K	13	2CDS 273 317 R0447	616249	0.42	3
	15	S 203 UP-K	15	2CDS 273 317 R0457	616256	0.42	3
	16	S 203 UP-K	16	2CDS 273 317 R0467	616263	0.42	3
	20	S 203 UP-K	20	2CDS 273 317 R0487	616270	0.42	3
	25	S 203 UP-K	25	2CDS 273 317 R0517	616287	0.42	3

4	0.2	S 204 UP-K	0.2	2CDS 274 317 R0087	616355	0.56	2
	0.3	S 204 UP-K	0.3	2CDS 274 317 R0117	616362	0.56	2
	0.5	S 204 UP-K	0.5	2CDS 274 317 R0157	616379	0.56	2
	0.75	S 204 UP-K	0.75	2CDS 274 317 R0187	616386	0.56	2
	1	S 204 UP-K	1	2CDS 274 317 R0217	616393	0.56	2
	1.6	S 204 UP-K	1.6	2CDS 274 317 R0257	616409	0.56	2
	2	S 204 UP-K	2	2CDS 274 317 R0277	616416	0.56	2
	3	S 204 UP-K	3	2CDS 274 317 R0317	616423	0.56	2
	4	S 204 UP-K	4	2CDS 274 317 R0337	616430	0.56	2
	5	S 204 UP-K	5	2CDS 274 317 R0357	616447	0.56	2
	6	S 204 UP-K	6	2CDS 274 317 R0377	616454	0.56	2
	8	S 204 UP-K	8	2CDS 274 317 R0407	616461	0.56	2
	10	S 204 UP-K	10	2CDS 274 317 R0427	616478	0.56	2
	13	S 204 UP-K	13	2CDS 274 317 R0447	616485	0.56	2
	15	S 204 UP-K	15	2CDS 274 317 R0457	616492	0.56	2
	16	S 204 UP-K	16	2CDS 274 317 R0467	616508	0.56	2
	20	S 204 UP-K	20	2CDS 274 317 R0487	616515	0.56	2
	25	S 204 UP-K	25	2CDS 274 317 R0517	616522	0.56	2

Z



S 200 UP-Z characteristic

Function: protection and control of the electronic circuits against weak and long duration overloads and short-circuits.

Applications: commercial and industrial.

Standard: IEC/EN 60947-2, UL 489, CSA 22.2 No. 5

Number of poles	Rated current	Order details		Bbn 4016779	Price 1 piece	Price group	Weight 1 piece	Pack unit
In A	Type code	Order code	EAN				kg	pc.
1	0.5	S 201 UP-Z 0.5	2CDS 271 317 R0158	616591			0.14	10
	1	S 201 UP-Z 1	2CDS 271 317 R0218	616607			0.14	10
	1.6	S 201 UP-Z 1.6	2CDS 271 317 R0258	616614			0.14	10
	2	S 201 UP-Z 2	2CDS 271 317 R0278	616621			0.14	10
	3	S 201 UP-Z 3	2CDS 271 317 R0318	616638			0.14	10
	4	S 201 UP-Z 4	2CDS 271 317 R0338	616645			0.14	10
	5	S 201 UP-Z 5	2CDS 271 317 R0358	616652			0.14	10
	6	S 201 UP-Z 6	2CDS 271 317 R0378	616669			0.14	10
	8	S 201 UP-Z 8	2CDS 271 317 R0408	616676			0.14	10
	10	S 201 UP-Z 10	2CDS 271 317 R0428	616683			0.14	10
	13	S 201 UP-Z 13	2CDS 271 317 R0448	616690			0.14	10
	15	S 201 UP-Z 15	2CDS 271 317 R0458	616706			0.14	10
	16	S 201 UP-Z 16	2CDS 271 317 R0468	616713			0.14	10
20	S 201 UP-Z 20	2CDS 271 317 R0488	616720			0.14	10	
25	S 201 UP-Z 25	2CDS 271 317 R0518	616737			0.14	10	
2	0.5	S 202 UP-Z 0.5	2CDS 272 317 R0158	616805			0.28	5
	1	S 202 UP-Z 1	2CDS 272 317 R0218	616812			0.28	5
	1.6	S 202 UP-Z 1.6	2CDS 272 317 R0258	616829			0.28	5
	2	S 202 UP-Z 2	2CDS 272 317 R0278	616836			0.28	5
	3	S 202 UP-Z 3	2CDS 272 317 R0318	616843			0.28	5
	4	S 202 UP-Z 4	2CDS 272 317 R0338	616850			0.28	5
	5	S 202 UP-Z 5	2CDS 272 317 R0358	616867			0.28	5
	6	S 202 UP-Z 6	2CDS 272 317 R0378	616874			0.28	5
	8	S 202 UP-Z 8	2CDS 272 317 R0408	616881			0.28	5
	10	S 202 UP-Z 10	2CDS 272 317 R0428	616898			0.28	5
	13	S 202 UP-Z 13	2CDS 272 317 R0448	616904			0.28	5
	15	S 202 UP-Z 15	2CDS 272 317 R0458	616911			0.28	5
	16	S 202 UP-Z 16	2CDS 272 317 R0468	616928			0.28	5
20	S 202 UP-Z 20	2CDS 272 317 R0488	616935			0.28	5	
25	S 202 UP-Z 25	2CDS 272 317 R0518	616942			0.28	5	

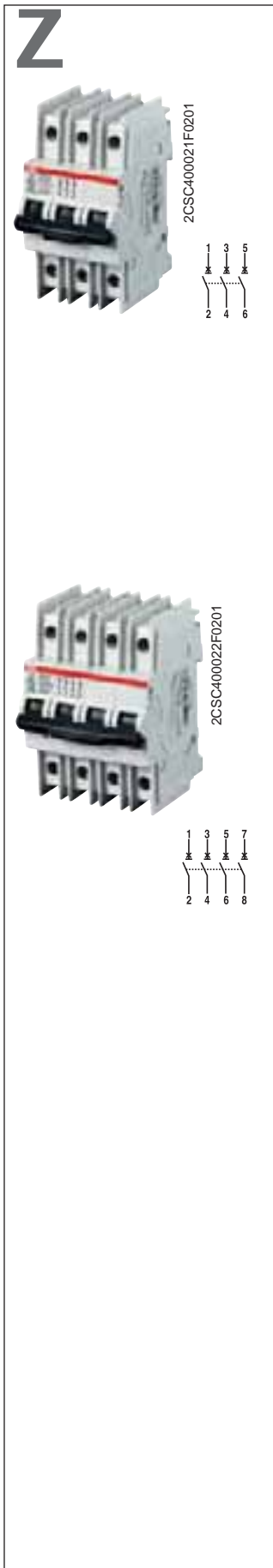

3	0.5	S 203 UP-Z	0.5	2CDS 273 317 R0158	617017	0.42	3
	1	S 203 UP-Z	1	2CDS 273 317 R0218	617024	0.42	3
	1.6	S 203 UP-Z	1.6	2CDS 273 317 R0258	617031	0.42	3
	2	S 203 UP-Z	2	2CDS 273 317 R0278	617048	0.42	3
	3	S 203 UP-Z	3	2CDS 273 317 R0318	617055	0.42	3
	4	S 203 UP-Z	4	2CDS 273 317 R0338	617062	0.42	3
	5	S 203 UP-Z	5	2CDS 273 317 R0358	617079	0.42	3
	6	S 203 UP-Z	6	2CDS 273 317 R0378	617086	0.42	3
	8	S 203 UP-Z	8	2CDS 273 317 R0408	617093	0.42	3
	10	S 203 UP-Z	10	2CDS 273 317 R0428	617109	0.42	3
	13	S 203 UP-Z	13	2CDS 273 317 R0448	617116	0.42	3
	15	S 203 UP-Z	15	2CDS 273 317 R0458	617123	0.42	3
	16	S 203 UP-Z	16	2CDS 273 317 R0468	617130	0.42	3
20	S 203 UP-Z	20	2CDS 273 317 R0488	617147	0.42	3	
25	S 203 UP-Z	25	2CDS 273 317 R0518	617154	0.42	3	

4	0.5	S 204 UP-Z	0.5	2CDS 274 317 R0158	617222	0.56	2
	1	S 204 UP-Z	1	2CDS 274 317 R0218	617239	0.56	2
	1.6	S 204 UP-Z	1.6	2CDS 274 317 R0258	617246	0.56	2
	2	S 204 UP-Z	2	2CDS 274 317 R0278	617253	0.56	2
	3	S 204 UP-Z	3	2CDS 274 317 R0318	617260	0.56	2
	4	S 204 UP-Z	4	2CDS 274 317 R0338	617277	0.56	2
	5	S 204 UP-Z	5	2CDS 274 317 R0358	617284	0.56	2
	6	S 204 UP-Z	6	2CDS 274 317 R0378	617291	0.56	2
	8	S 204 UP-Z	8	2CDS 274 317 R0408	617307	0.56	2
	10	S 204 UP-Z	10	2CDS 274 317 R0428	617314	0.56	2
	13	S 204 UP-Z	13	2CDS 274 317 R0448	617321	0.56	2
	15	S 204 UP-Z	15	2CDS 274 317 R0458	617338	0.56	2
	16	S 204 UP-Z	16	2CDS 274 317 R0468	617345	0.56	2
20	S 204 UP-Z	20	2CDS 274 317 R0488	617352	0.56	2	
25	S 204 UP-Z	25	2CDS 274 317 R0518	617369	0.56	2	



2CSC400133F0201



2CSC400129F0201



2CSC400005F0201

The S 9.. range of circuit-breakers is the widest range of 1P+N MCBs in one module.

These circuit-breakers are available with rated currents from 2 to 40 A when using the characteristic C and with rated currents from 6 to 40 A when using the characteristic B.

For each current there are also four different breaking capacities available:

3 kA (S 931 N series) 4.5 kA (S 941 N series), 6 kA (S 951 N series) and 10 kA (S 971 N series).

These circuit-breakers have been designed so that they ensure, in the last closing section, that the closing speed of the contacts is independent of the rotating

speed of the knob. The trip device (ABB international patent) ensures perfect closure every time thus considerably improving the performance of these devices and extending the average life cycle. A redesigned red/green

toggle makes the ON/OFF status immediately evident. The terminals have also been designed for safe and easy use and, to this end, new high capacity cage type terminals (16 mm² on all versions) have

been developed. The S 9.. range circuit-breakers have been designed for wiring with the ABB SACE Unifix rapid system using special connections. These circuit-breakers are also supported by a complete group of auxiliary elements which effect many functions and configurations such as auxiliary contacts, signal contacts, undervoltage releases and shunt trips.



2CSC400134F0201



Index

Technical features of MCBs S 9.. series	2/48
Selection tables of MCBs S 9.. series	
S 931 N-C	2/50
S 941 N-B	2/51
S 941 N-C	2/51
S 951 N-B	2/52
S 951 N-C	2/52
S 971 N-B	2/53
S 971 N-C	2/53

TECHNICAL FEATURES			
Standards			
Electrical features	Rated current I_n	A	
	Poles		
	Rated voltage U_e	V	
	Insulation voltage U_i	V	
	Max. operating voltage U_b max.	IEC AC	V
		IEC DC 1P	V
		IEC DC 1P+N	V
	Min. operating voltage U_b min.	V	
	Rated frequency	Hz	
	Rated breaking capacity acc. to IEC/EN 60898	ultimate I_{cn}	A
	Rated making and breaking capacity of an individual pole	I_{cn1}	kA
	Rated breaking capacity acc. to IEC/EN 60947-2 1P, 1P+N @ 230 VAC	ultimate I_{cu}	kA
		service I_{cs}	kA
	Rated impulse withstand voltage (1.2/50) U_{imp}		kV
	Dielectric test voltage at ind. freq. for 1 min.		kV
Overvoltage category			
Thermomagnetic release characteristic	B: $3 I_n \leq I_m \leq 5 I_n$		
	C: $5 I_n \leq I_m \leq 10 I_n$		
Mechanical features	Toggle		
	Electrical life		
	Mechanical life		
	Protection degree	housing	
		terminals	
	Tropicalization acc. to IEC/EN 60068-2	humid heat	°C/RH
		constant climatic conditions	°C/RH
		variable climatic conditions	°C/RH
	Reference temperature for setting of thermal element		°C
	Ambient temperature (with daily average $\leq +35$ °C)		°C
Storage temperature		°C	
Installation	Terminal type		
	Terminal size top/bottom for cable		mm ²
	Tightening torque		N*m
	Mounting		
	Connection		
Dimensions and weight	Pole dimensions (H x D x W)		mm
	Pole weight		g
Combination with auxiliary elements	Combinable with:	auxiliary contact	
		signal contact	
		shunt trip	
		undervoltage release	



S 931N	S 941N	S 951N	S 971N
IEC/EN 60898			
2 ≤ In ≤ 40			
1P+N			
230			
500			
254			
60			
125			
12VAC - 12VDC			
50...60			
3000	4500	6000	10000
3	3	3	3
4.5	6	10	10
3	4.5	6	7.5
5			
2.5			
III			
■	■	■	■
black sealable in ON-OFF position			
10000			
20000			
IP4X			
IP2X			
28 cycles with 55/95...100			
23/83 - 40/93 - 55/20			
25/95 - 40/95			
30			
-25...+55			
-40...+70			
cage (shock resistant)			
16/16			
1.2			
on DIN rail EN 60715 (35 mm) by means of fast clip device			
from top and bottom			
83 x 68 x 17.8			
110			
yes			
yes			
yes			
yes			

C



2CSC400483F0201

S 931N C characteristic

Function: protection and control of the circuits against overloads and short-circuits in final distribution; protection for resistive and inductive loads with low inrush current.

Applications: residential.

Standard: IEC/EN 60898

I_{cn}=3 kA

Number of poles	Nominal current In A	Order details		Bbn	Price	Price	Weight	Pack
		Type	Order code	8012542	1 piece	group	1 piece	unit
				EAN			kg	pc.
1+N	2	S 931N C2	11861114	496908			0.110	6
	4	S 931N C4	11861115	497004			0.110	6
	6	S 931N C6	11861116	497103			0.110	6
	10	S 931N C10	11861117	497202			0.110	6
	13	S 931N C13	11861123	776703			0.110	6
	16	S 931N C16	11861118	497301			0.110	6
	20	S 931N C20	11861119	497400			0.110	6
	25	S 931N C25	11861120	497509			0.110	6
	32	S 931N C32	11861121	497608			0.110	6
	40	S 931N C40	11861122	497707			0.110	6

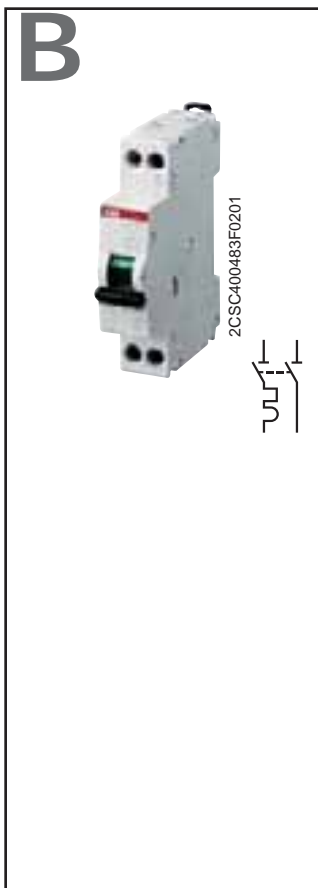

S 941N B characteristic

Function: protection and control of the circuits against overloads and short-circuits in final distribution; protection for people and big length cables in TN and IT systems.

Applications: residential.

Standard: IEC/EN 60898

Icn=4.5 kA

Number of poles	Nominal current In A	Order details		Bbn	Price 1 piece	Price group	Weight 1 piece kg	Pack unit pc.
		Type	Order code	8012542 EAN				
1+N	6	S 941N B6	16055409	353607			0.110	6
	10	S 941N B10	16055417	353706			0.110	6
	16	S 941N B16	16055425	353805			0.110	6
	20	S 941N B20	16055433	353904			0.110	6
	25	S 941N B25	16055441	354000			0.110	6
	32	S 941N B32	16055458	354109			0.110	6
	40	S 941N B40	16055466	354208			0.110	6

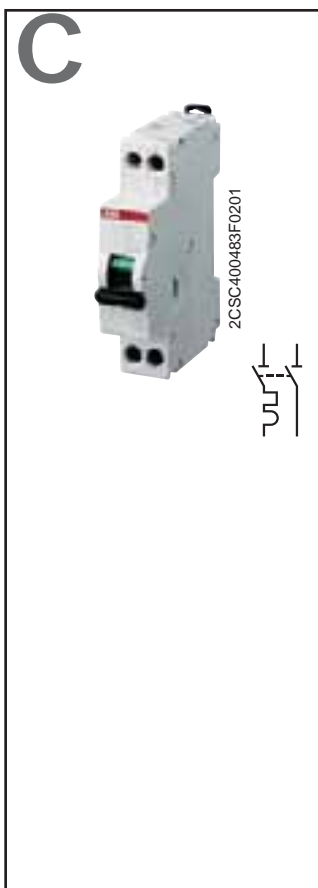

S 941N C characteristic

Function: protection and control of the circuits against overloads and short-circuits in final distribution; protection for resistive and inductive loads with low inrush current.

Applications: residential.

Standard: IEC/EN 60898

Icn=4.5 kA

Number of poles	Nominal current In A	Order details		Bbn	Price 1 piece	Price group	Weight 1 piece kg	Pack unit pc.
		Type	Order code	8012542 EAN				
1+N	2	S 941N C2	16055508	354307			0.110	6
	4	S 941N C4	16055516	354406			0.110	6
	6	S 941N C6	16055524	354505			0.110	6
	10	S 941N C10	16055532	354604			0.110	6
	13	S 941N C13	16055482	776802			0.110	6
	16	S 941N C16	16055540	354703			0.110	6
	20	S 941N C20	16055557	354802			0.110	6
	25	S 941N C25	16055565	354901			0.110	6
	32	S 941N C32	16055573	355007			0.110	6
	40	S 941N C40	16055581	355106			0.110	6

B



S 951N B characteristic

Function: protection and control of the circuits against overloads and short-circuits in final distribution; protection for people and big length cables in TN and IT systems.

Applications: residential and commercial.

Standard: IEC/EN 60898

Icn=6 kA

Number of poles	Nominal current In A	Order details		Bbn 8012542 EAN	Price 1 piece	Price group	Weight 1 piece kg	Pack unit pc.
		Type	Order code					
1+N	6	S 951N B6	16055607	355205			0.110	6
	10	S 951N B10	16055615	355304			0.110	6
	16	S 951N B16	16055623	355403			0.110	6
	20	S 951N B20	16055631	355502			0.110	6
	25	S 951N B25	16055649	355601			0.110	6
	32	S 951N B32	16055656	355700			0.110	6
	40	S 951N B40	16055664	355809			0.110	6

C



S 951N C characteristic

Function: protection and control of the circuits against overloads and short-circuits in final distribution; protection for resistive and inductive loads with low inrush current.

Applications: residential and commercial.

Standard: IEC/EN 60898

Icn=6 kA

Number of poles	Nominal current In A	Order details		Bbn 8012542 EAN	Price 1 piece	Price group	Weight 1 piece kg	Pack unit pc.
		Type	Order code					
1+N	2	S 951N C2	16055706	355908			0.110	6
	4	S 951N C4	16055714	356004			0.110	6
	6	S 951N C6	16055722	356103			0.110	6
	10	S 951N C10	16055730	356202			0.110	6
	13	S 951N C13	16055797	450801			0.110	6
	16	S 951N C16	16055748	356301			0.110	6
	20	S 951N C20	16055755	356400			0.110	6
	25	S 951N C25	16055763	356509			0.110	6
	32	S 951N C32	16055771	356608			0.110	6
	40	S 951N C40	16055789	356707			0.110	6

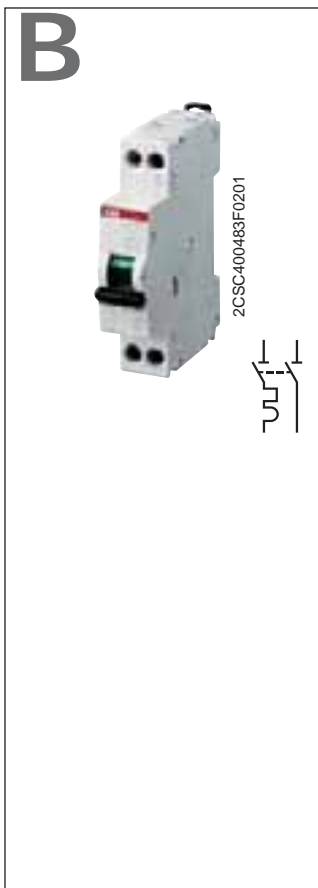

S 971N B characteristic

Function: protection and control of the circuits against overloads and short-circuits in final distribution; protection for people and big length cables in TN and IT systems.

Applications: residential and commercial.

Standard: IEC/EN 60898

I_{cn}=10 kA

Number of poles	Nominal current In A	Order details		Bbn 8012542 EAN	Price 1 piece	Price group	Weight 1 piece kg	Pack unit pc.
		Type	Order code					
1+N	6	S 971N B6	16055805	356806			0.110	6
	10	S 971N B10	16055813	356905			0.110	6
	16	S 971N B16	16055821	357001			0.110	6
	20	S 971N B20	16055839	357100			0.110	6
	25	S 971N B25	16055847	357209			0.110	6
	32	S 971N B32	16055854	357308			0.110	6
	40	S 971N B40	16055862	357407			0.110	6

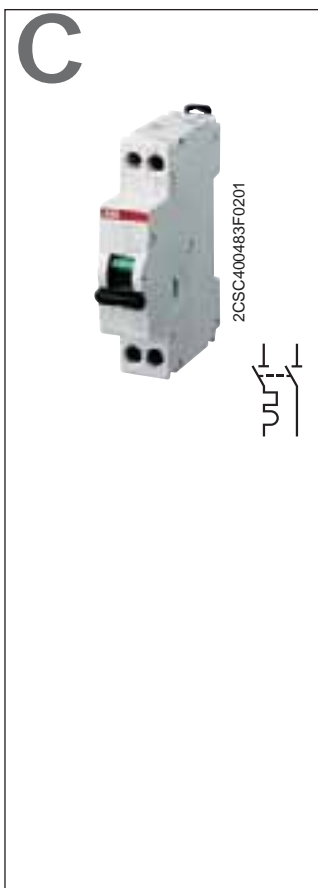

S 971N C characteristic

Function: protection and control of the circuits against overloads and short-circuits in final distribution; protection for resistive and inductive loads with low inrush current.

Applications: residential and commercial.

Standard: IEC/EN 60898

I_{cn}=10 kA

Number of poles	Nominal current In A	Order details		Bbn 8012542 EAN	Price 1 piece	Price group	Weight 1 piece kg	Pack unit pc.
		Type	Order code					
1+N	2	S 971N C2	16055904	357506			0.110	6
	4	S 971N C4	16055912	357605			0.110	6
	6	S 971N C6	16055920	357704			0.110	6
	10	S 971N C10	16055938	357803			0.110	6
	13	S 971N C13	16055896	776901			0.110	6
	16	S 971N C16	16055946	357902			0.110	6
	20	S 971N C20	16055953	358008			0.110	6
	25	S 971N C25	16055961	358107			0.110	6
	32	S 971N C32	16055979	358206			0.110	6
	40	S 971N C40	16055987	358305			0.110	6

MCBs for heavy-duty industrial protection consist of three different ranges.

S 280 series, which includes the 80 A and 100 A rated current versions (one pole, one module), available in B and C characteristics, 6 kA breaking capacity according to IEC/EN 60898 Standard and 35 mm² size of the terminals. The range includes also the S 280 UC series that protects direct current circuits with high voltages.

In all circuit-breakers of the range there is no specific mechanical constraint between the case and the internal mechanical components which form three independent functional blocks: in this way, any distortion of the case, in the event of thermal shock, does not affect the correct functioning of the circuit-breaker. The supply lines of the protected circuit can be connected to either the upper or lower terminals of the circuit-breakers (reversibility of connections). The double terminal of these circuit-breakers enables simultaneous connection of cables and busbars.

S 290 series, for the use in switchboards and consumer units for modular devices with 45 mm slotting and rated currents up to 125 A. They can be



2CSC400395F0201



2CSC400396F0201



2CSC400566F0201

mounted alongside standard modular circuit-breakers because of their modular design and ability to be installed on 35 mm DIN EN 50022 rails. The circuit-breakers are available in 1-2-3-4 pole versions with a width equal to 1 module and a half per pole (27 mm); the characteristic curves are C, D and K.

The extensive **S800** range offers the right high performance MCBs with high-rated breaking capacities and various tripping characteristics. The units of the

S 800 S series, both AC and DC types, operate in a nominal current range of between 10 and 125 A covering breaking capacities of up to 50 kA.

The S800 N is the ideal solution for applications of up to 36 kA; of course also for current ratings of between 10 and 125 A.

The high-rated breaking capacities of up to 50 kA allow electrical distribution systems to be configured and operated safely in an uncomplicated manner.

Compact dimensions ensu-

re that energy distribution systems can be set up in a space-saving way. S800 MCBs satisfy all the main standards and approvals.



Index

Technical features of MCBs S 280 series 80-100 A	2/56
Selection tables of MCBs S 280 series 80-100 A	
S 280 80-100 A-B	2/57
S 280 80-100 A-C.....	2/57
Technical features of MCBs S 280 UC series	2/58
Selection tables of MCBs S 280 UC series	
S 280-UC B	2/59
S 280-UC K	2/60
S 280-UC Z.....	2/62
Technical features of MCBs S 290 series	2/64
Selection tables of MCBs S 290 series	
S 290-C	2/65
S 290-D	2/66
S 290-K.....	2/67
Technical features of MCBs S800 series	2/68
Selection tables of MCBs S800 series	
S800 S-B	2/70
S800 S-C	2/72
S800 S-D	2/74
S800 S-K	2/76
S800 S-KM	2/78
S800 S-KM-R	2/78
S800 S-UC B	2/79
S800 S-UC K	2/81
S800 N-B	2/83
S800 N-C	2/84
S800 N-D	2/85



TECHNICAL FEATURES			S 280 80- 100A	
Standards			IEC/EN 60898; IEC/EN 60947-2	
Electrical feature	Rated current I_n	A	$80 \leq I_n \leq 100$	
	Poles		1P, 2P, 3P, 4P	
	Rated voltage U_e	IEC AC 1P	V	230-240
		IEC AC 2P, 3P, 4P	V	230/400-240/415
	Insulation voltage U_i		V	500
	Max. operating voltage U_b max.	IEC AC	V	254/440
		IEC DC 1P	V	60
		IEC DC 2P, 3P, 4P	V	125
	Min. operating voltage U_b min.		V	12 VAC - 12 VDC
	Rated frequency		Hz	50...60
	Rated breaking capacity acc. to IEC/EN 60898	ultimate I_{cn}	A	6000
	Rated breaking capacity acc. to IEC/EN 60947-2 1P @ 230 VAC 2P, 3P, 4P@ 400 VAC	ultimate I_{cu}	kA	6
		service I_{cs}	kA	6
	Rated impulse withstand voltage (1.2/50) U_{imp}		kV	5
	Dielectric test voltage at ind. freq. for 1 min.		kV	2.5
Overvoltage category			III	
Thermomagnetic release characteristic	B: $3 I_n \leq I_m \leq 5 I_n$		■	
	C: $5 I_n \leq I_m \leq 10 I_n$		■	
Mechanical feature	Toggle		black sealable in ON- OFF position	
	Electrical life		4000	
	Mechanical life		10000	
	Protection degree	housing		IP4X
		terminals		IP2X
	Mechanical shock resistance		30 g, minimum of 2 impacts, duration of shocks 13 ms	
	Resistance to vibrations acc. to IEC/EN 60068-2-6		5 g - 20 cycles at frequency 5...150...5 Hz with load 0.8 I_n	
	Tropicalization acc. to IEC/EN 60068-2	humid heat	°C/RH	28 cycles with 55/95...100
		constant climatic conditions	°C/RH	23/83 - 40/93 - 55/20
		variable climatic conditions	°C/RH	25/95 - 40/95
	Reference temperature for setting of thermal element		°C	30
	Ambient temperature (with daily average $\leq +35^\circ\text{C}$)		°C	-25...+55
Storage temperature		°C	-40...+70	
Installation	Terminal type		cage (shock protected)	
	Terminal size top/bottom for cable	mm ²	35/35	
	Tightening torque	N*m	2.5	
	Mounting		on DIN rail EN 60715 (35 mm) by means of fast clip device	
	Connection		from top and bottom	
Dimensions and weight	Pole dimensions (H x D x W)	mm	90 x 68 x 17.5	
	Pole weight	g	160	
Combination with auxiliary elements	Combinable with:	signal contact/auxiliary switch	yes	
		shunt trip	yes	
		undervoltage release	yes	

6000

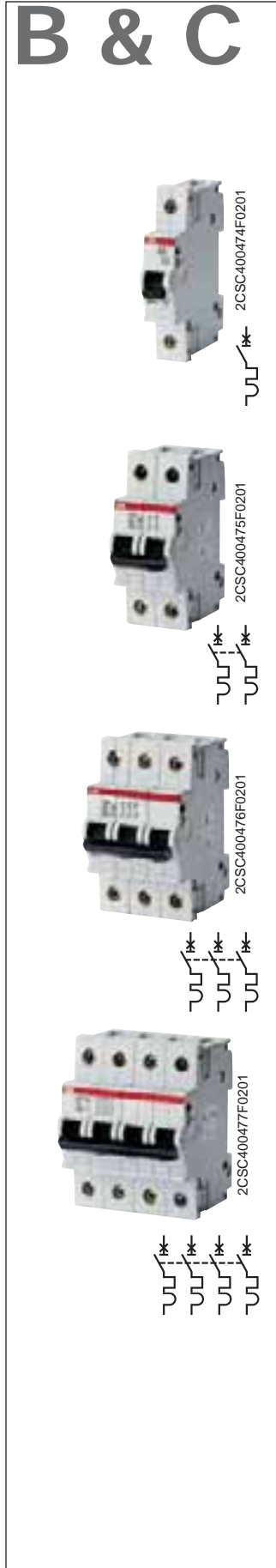

S 280 80-100A B characteristic

Function: protection and control of the circuits against overloads and short-circuits; protection for people and big length cables in TN and IT systems.

Applications: commercial and industrial.

Standard: IEC/EN 60898, IEC/EN 60947-2

Icn=6 kA

Number of poles	Rated current	Order details		Bbn 8012542	Price 1 piece	Price group	Weight 1 piece	Pack unit
		In A	Type code					
1	80	S281 B80	GHS2810001R0805	499503			0.140	1/6
	100	S281 B100	GHS2810001R0825	499602			0.140	1/6

2	80	S282 B80	GHS2820001R0805	500100			0.275	1/3
	100	S282 B100	GHS2820001R0825	500209			0.275	1/3

3	80	S283 B80	GHS2830001R0805	500704			0.400	1/2
	100	S283 B100	GHS2830001R0825	500803			0.400	1/2

4	80	S284 B80	GHS2840001R0805	518006			0.525	1
	100	S284 B100	GHS2840001R0825	518105			0.525	1

S 280 80-100A C characteristic

Function: protection and control of the circuits against overloads and short-circuits; protection for resistive and inductive loads with low inrush current.

Applications: commercial and industrial.

Standard: IEC/EN 60898, IEC/EN 60947-2

Icn=6 kA

Number of poles	Rated current	Order details		Bbn 8012542	Price 1 piece	Price group	Weight 1 piece	Pack unit
		In A	Type code					
1	80	S281 C80	GHS2810001R0804	499305			0.140	1/6
	100	S281 C100	GHS2810001R0824	499404			0.140	1/6

2	80	S282 C80	GHS2820001R0804	499909			0.275	1/3
	100	S282 C100	GHS2820001R0824	500001			0.275	1/3

3	80	S283 C80	GHS2830001R0804	500506			0.400	1/2
	100	S283 C100	GHS2830001R0824	500605			0.400	1/2

4	80	S284 C80	GHS2840001R0804	517801			0.525	1
	100	S284 C100	GHS2840001R0824	517900			0.525	1



TECHNICAL FEATURES			S 280 UC		
Standards			IEC/EN 60947-2, UL1077 ①, CSA22.2 No.235 ①		
Electrical features	Rated current I_n	A	0.5 ≤ I_n ≤ 40 50 ≤ I_n ≤ 63		
	Poles		1P, 2P		
	Rated voltage U_e	IEC DC 1P	V	220	
		IEC DC 2P, 3P, 4P	V	440	
		UL/CSA DC 1P	V	250	
		UL/CSA DC 2P, 3P, 4P	V	500	
	Insulation voltage U_i		500		
	Max. operating voltage U_b max.	IEC AC	V	254/440	
		UL/CSA AC	V	480 Y/277	
		IEC/UL/CSA DC 1P	V	250	
		IEC/UL/CSA DC 2P, 3P, 4P	V	500	
	Min. operating voltage U_b min.		12 VAC - 12 VDC		
	Rated frequency		50...60		
	Rated breaking capacity acc. to IEC/EN 60947-2 1P@ 220 VDC 2P, 3P, 4P@ 440 VDC	ultimate I_{cu}	kA	6	4.5
		service I_{cs}	kA	6	4.5
	Rated interrupting capacity acc. to UL1077, CSA22.2 No.235 1P@60 VDC 2P,3P,4P@125 VDC	IR	kA (RMS)	10	
	Rated impulse withstand voltage (1.2/50) U_{imp}		kV	5	
Dielectric test voltage at ind. freq. for 1 min.		kV	2.5		
Overvoltage category			III		
Thermomagnetic release characteristic	B: 3 I_n ≤ I_m ≤ 5 I_n		■	■	
	K: 8 I_n ≤ I_m ≤ 14 I_n		■	■	
	Z: 2 I_n ≤ I_m ≤ 3 I_n		■	■	
Mechanical features	Toggle		black sealable in ON- OFF position		
	Electrical life		10000		
	Mechanical life		20000		
Protection degree	housing		IP4X		
	terminals		IP2X		
Mechanical shock resistance			30 g, minimum of 2 impacts, duration of shocks 13 ms		
Resistance to vibrations acc. to IEC/EN 60068-2-6			5 g - 20 cycles at frequency 5...150...5 Hz with load 0,8 I_n		
Tropicalization acc. to IEC/EN 60068-2	humid heat	°C/RH	28 cycles with 55/95...100		
	constant climatic conditions	°C/RH	23/83 - 40/93 - 55/20		
	variable climatic conditions	°C/RH	25/95 - 40/95		
Reference temperature for setting of thermal element		°C	30 (20 for characteristics K,Z)		
Ambient temperature (with daily average ≤ +35°C)	IEC	°C	-25...+55		
	UL/CSA	°C	-25...+70		
Storage temperature		°C	-40...+70		
Installation	Terminal type		cage (shock protected)		
Terminal size top/bottom for cable	IEC	mm ²	25/25		
	UL/CSA	AWG	18-16		
Tightening torque	IEC	N*m	2		
	UL/CSA	in-lbs.	17.5		
Tool			No. 2 Posidriv		
Mounting			on DIN rail EN 60715 (35 mm) by means of fast clip device		
Connection			from top or bottom, according to the position of load (see wiring diagrams)		
Dimensions and weight	Pole dimensions (H x D x W)	mm	90 x 68 x 17.5		
	Pole weight	g	140		
Combination with auxiliary elements	Combinable with:	signal contact/auxiliary switch	yes		
		shunt trip	yes		
		undervoltage release	yes		

B



2CSC400474F0201



2CSC400475F0201



S 280 series UC B characteristic

Function: protection and control of the circuits against overloads and short-circuits; protection for people and big length cables in TN and IT systems; version dedicated to application in direct current circuits for voltages up to 220 V DC 1 pole and 440 V DC 2, 3 and 4 poles.

Applications: industrial.

Standard: IEC/EN 60947-2

Icn=6 kA

Number of poles	Rated current	Order details	Bbn 4016779	Price 1 piece	Price group	Weight 1 piece	Pack unit
	In A	Type code	Order code	EAN		kg	pc.
1	6	S281-UC B 6	GHS2810164R0065	162302		0.130	10/40
	10	S281-UC B10	GHS2810164R0105	162401		0.130	10/40
	UBmax 16	S281-UC B16	GHS2810164R0165	162500		0.130	10/40
	440 V~ 20	S281-UC B20	GHS2810164R0205	162609		0.130	10/40
	220 V -... 25	S281-UC B25	GHS2810164R0255	162708		0.130	10/40

2	6	S282-UC B 6	GHS2820164R0065	162807		0.260	5/20
	10	S282-UC B10	GHS2820164R0105	162906		0.260	5/20
	UBmax 16	S282-UC B16	GHS2820164R0165	163002		0.260	5/20
	440 V~ 20	S282-UC B20	GHS2820164R0205	163101		0.260	5/20
	440 V -... 25	S282-UC B25	GHS2820164R0255	163200		0.260	5/20

K



2CSC400474F0201



2CSC400475F0201



S 280 series UC K (power) characteristic

Function: protection and control of the circuits like motors and auxiliary circuits, against overloads and short-circuits; version dedicated to application in direct current circuits for voltages up to 220 V DC 1 pole and 440 V DC 2, 3 and 4 poles.

Advantages: no nuisance tripping in the case of functional peak currents up to $8I_n$, depending on the series; through its highly sensitive thermostatic bimetal trip, the K-type characteristic offers protection to damageable elements in the overcurrent range; it also provides the best protection to cables and lines.

Applications: industrial.

Standard: IEC/EN 60947-2, VDE 0660 Part 101

I_{cn} =6 kA

Number of poles	Rated current	Order details	Bbn 4012233	Price 1 piece	Price group	Weight 1 piece	Pack unit
	In A	Type code	Order code	EAN		kg	pc.
1	0.2	S 281 UC-K 0.2	GHS2810164R0087	634200		0.130	10/40
	0.3	S 281 UC-K 0.3	GHS2810164R0117	634309		0.130	10/40
	0.5	S 281 UC-K 0.5	GHS2810164R0157	634408		0.130	10/40
	0.75	S 281 UC-K 0.75	GHS2810164R0187	635504		0.130	10/40
	1	S 281 UC-K 1	GHS2810164R0217	634606		0.130	10/40
	1.6	S 281 UC-K 1.6	GHS2810164R0257	634705		0.130	10/40
	2	S 281 UC-K 2	GHS2810164R0277	634804		0.130	10/40
	3	S 281 UC-K 3	GHS2810164R0317	634903		0.130	10/40
	4	S 281 UC-K 4	GHS2810164R0337	635009		0.130	10/40
	6	S 281 UC-K 6	GHS2810164R0377	635207		0.130	10/40
	8	S 281 UC-K 8	GHS2810164R0407	635108		0.130	10/40
	10	S 281 UC-K 10	GHS2810164R0427	635306		0.130	10/40
	16	S 281 UC-K 16	GHS2810164R0467	635405		0.130	10/40
	20	S 281 UC-K 20	GHS2810164R0487	635603		0.130	10/40
	25	S 281 UC-K 25	GHS2810164R0517	635702		0.130	10/40
32	S 281 UC-K 32	GHS2810164R0537	635801		0.130	10/40	
_UBmax	40	S 281 UC-K 40	GHS2810164R0557	635900		0.130	10/40
440 V~	50	S 281 UC-K 50	GHS2810164R0577	636006		0.160	10/40
220 V ~...	63	S 281 UC-K 63	GHS2810164R0607	636105		0.160	10/40

2	0.2	S 282 UC-K 0.2	GHS2820164R0087	636204		0.260	5/20
	0.3	S 282 UC-K 0.3	GHS2820164R0117	636303		0.260	5/20
	0.5	S 282 UC-K 0.5	GHS2820164R0157	636402		0.260	5/20
	0.75	S 282 UC-K 0.75	GHS2820164R0187	636501		0.260	5/20
	1	S 282 UC-K 1	GHS2820164R0217	636600		0.260	5/20
	1.6	S 282 UC-K 1.6	GHS2820164R0257	636709		0.260	5/20
	2	S 282 UC-K 2	GHS2820164R0277	652808		0.260	5/20
	3	S 282 UC-K 3	GHS2820164R0317	636808		0.260	5/20
	4	S 282 UC-K 4	GHS2820164R0337	636907		0.260	5/20
	6	S 282 UC-K 6	GHS2820164R0377	637003		0.260	5/20
	8	S 282 UC-K 8	GHS2820164R0407	637102		0.260	5/20
	10	S 282 UC-K 10	GHS2820164R0427	637201		0.260	5/20
	16	S 282 UC-K 16	GHS2820164R0467	637300		0.260	5/20
	20	S 282 UC-K 20	GHS2820164R0487	637409		0.260	5/20
	25	S 282 UC-K 25	GHS2820164R0517	637508		0.260	5/20
32	S 282 UC-K 32	GHS2820164R0537	637607		0.260	5/20	
_UBmax	40	S 282 UC-K 40	GHS2820164R0557	637706		0.260	5/20
440 V~	50	S 282 UC-K 50	GHS2820164R0577	637904		0.320	5/20
440 V ~...	63	S 282 UC-K 63	GHS2820164R0607	638000		0.320	5/20

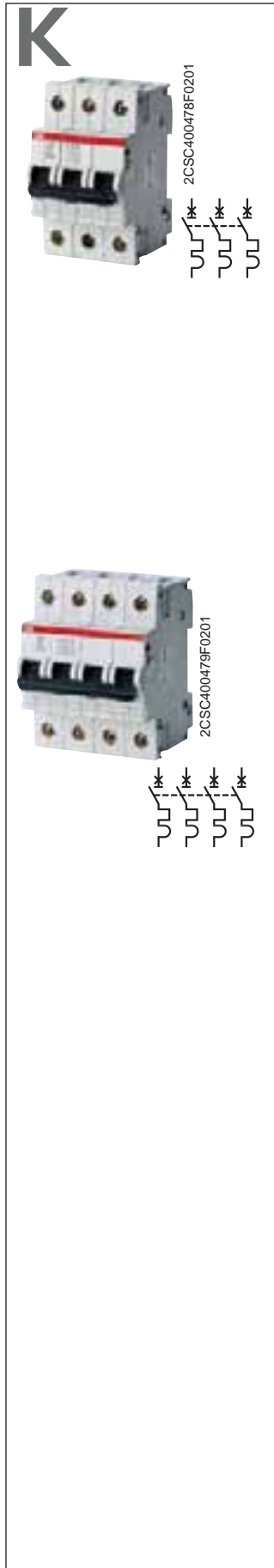

3	0.2	S 283 UC-K 0.2	GHS2830164R0087	738106	0.390	3/12
	0.3	S 283 UC-K 0.3	GHS2830164R0117	738205	0.390	3/12
	0.5	S 283 UC-K 0.5	GHS2830164R0157	738304	0.390	3/12
	0.75	S 283 UC-K 0.75	GHS2830164R0187	738403	0.390	3/12
	1	S 283 UC-K 1	GHS2830164R0217	738502	0.390	3/12
	1.6	S 283 UC-K 1.6	GHS2830164R0257	738601	0.390	3/12
	2	S 283 UC-K 2	GHS2830164R0277	738700	0.390	3/12
	3	S 283 UC-K 3	GHS2830164R0317	738809	0.390	3/12
	4	S 283 UC-K 4	GHS2830164R0337	738908	0.390	3/12
	6	S 283 UC-K 6	GHS2830164R0377	739004	0.390	3/12
	8	S 283 UC-K 8	GHS2830164R0407	739103	0.390	3/12
	10	S 283 UC-K 10	GHS2830164R0427	739202	0.390	3/12
	16	S 283 UC-K 16	GHS2830164R0467	739301	0.390	3/12
	20	S 283 UC-K 20	GHS2830164R0487	739400	0.390	3/12
	25	S 283 UC-K 25	GHS2830164R0517	739509	0.390	3/12
	32	S 283 UC-K 32	GHS2830164R0537	739608	0.390	3/12
_UBmax	40	S 283 UC-K 40	GHS2830164R0557	739707	0.390	3/12
440 V~	50	S 283 UC-K 50	GHS2830164R0577	739806	0.480	3/12
440 V -...	63	S 283 UC-K 63	GHS2830164R0607	739905	0.480	3/12

4	0.2	S 284 UC-K 0.2	GHS2840164R0087	741601	0.520	2
	0.3	S 284 UC-K 0.3	GHS2840164R0117	741700	0.520	2
	0.5	S 284 UC-K 0.5	GHS2840164R0157	741809	0.520	2
	0.75	S 284 UC-K 0.75	GHS2840164R0187	741908	0.520	2
	1	S 284 UC-K 1	GHS2840164R0217	742004	0.520	2
	1.6	S 284 UC-K 1.6	GHS2840164R0257	742103	0.520	2
	2	S 284 UC-K 2	GHS2840164R0277	742202	0.520	2
	3	S 284 UC-K 3	GHS2840164R0317	742301	0.520	2
	4	S 284 UC-K 4	GHS2840164R0337	742400	0.520	2
	6	S 284 UC-K 6	GHS2840164R0377	742509	0.520	2
	8	S 284 UC-K 8	GHS2840164R0407	742608	0.520	2
	10	S 284 UC-K 10	GHS2840164R0427	742707	0.520	2
	16	S 284 UC-K 16	GHS2840164R0467	742806	0.520	2
	20	S 284 UC-K 20	GHS2840164R0487	743001	0.520	2
	25	S 284 UC-K 25	GHS2840164R0517	743100	0.520	2
	32	S 284 UC-K 32	GHS2840164R0537	743209	0.520	2
_UBmax	40	S 284 UC-K 40	GHS2840164R0557	743308	0.520	2
440 V~	50	S 284 UC-K 50	GHS2840164R0577	743407	0.640	2
440 V -...	63	S 284 UC-K 63	GHS2840164R0607	743506	0.640	2

Z

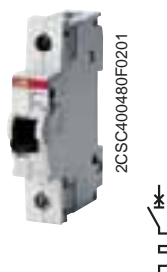

2CSC400480F0201

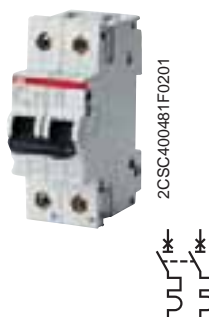

2CSC400481F0201



S 280 series UC Z characteristic

Function: protection and control of the electronic circuits against weak and long duration overloads and short-circuits; version dedicated to application in direct current circuits for voltages up to 220 V DC 1 pole and 440 V DC 2, 3 and 4 poles.

Applications: industrial.

Standard: IEC/EN 60947-2, VDE 0660 Part 101

I_{cn}=6 kA

Number of poles	Rated current	Order details		Bbn 4012233	Price 1 piece	Price group	Weight 1 piece	Pack unit	
	In A	Type code	Order code	EAN			kg	pc.	
1	0.5	S 281 UC-Z 0.5	GHS2810164R0158	638604			0.130	10/40	
	1	S 281 UC-Z 1	GHS2810164R0218	638703			0.130	10/40	
	1.6	S 281 UC-Z 1.6	GHS2810164R0258	638802			0.130	10/40	
	2	S 281 UC-Z 2	GHS2810164R0278	638901			0.130	10/40	
	3	S 281 UC-Z 3	GHS2810164R0318	639007			0.130	10/40	
	4	S 281 UC-Z 4	GHS2810164R0338	639106			0.130	10/40	
	6	S 281 UC-Z 6	GHS2810164R0378	639205			0.130	10/40	
	8	S 281 UC-Z 8	GHS2810164R0408	639403			0.130	10/40	
	10	S 281 UC-Z 10	GHS2810164R0428	639502			0.130	10/40	
	16	S 281 UC-Z 16	GHS2810164R0468	639601			0.130	10/40	
	20	S 281 UC-Z 20	GHS2810164R0488	639700			0.130	10/40	
	25	S 281 UC-Z 25	GHS2810164R0518	639809			0.130	10/40	
	32	S 281 UC-Z 32	GHS2810164R0538	639908			0.130	10/40	
	_UBmax	40	S 281 UC-Z 40	GHS2810164R0558	640003			0.130	10/40
	440 V~	50	S 281 UC-Z 50	GHS2810164R0578	640102			0.160	10/40
220 V ~...	63	S 281 UC-Z 63	GHS2810164R0608	640201			0.160	10/40	

2	0.5	S 282 UC-Z 0.5	GHS2820164R0158	640300			0.260	5/20	
	1	S 282 UC-Z 1	GHS2820164R0218	640409			0.260	5/20	
	1.6	S 282 UC-Z 1.6	GHS2820164R0258	642304			0.260	5/20	
	2	S 282 UC-Z 2	GHS2820164R0278	641000			0.260	5/20	
	3	S 282 UC-Z 3	GHS2820164R0318	641109			0.260	5/20	
	4	S 282 UC-Z 4	GHS2820164R0338	641208			0.260	5/20	
	6	S 282 UC-Z 6	GHS2820164R0378	641307			0.260	5/20	
	8	S 282 UC-Z 8	GHS2820164R0408	641406			0.260	5/20	
	10	S 282 UC-Z 10	GHS2820164R0428	641505			0.260	5/20	
	16	S 282 UC-Z 16	GHS2820164R0468	641604			0.260	5/20	
	20	S 282 UC-Z 20	GHS2820164R0488	641703			0.260	5/20	
	25	S 282 UC-Z 25	GHS2820164R0518	641802			0.260	5/20	
	32	S 282 UC-Z 32	GHS2820164R0538	641901			0.260	5/20	
	_UBmax	40	S 282 UC-Z 40	GHS2820164R0558	642007			0.260	5/20
	440 V~	50	S 282 UC-Z 50	GHS2820164R0578	642106			0.320	5/20
440 V ~...	63	S 282 UC-Z 63	GHS2820164R0608	642205			0.320	5/20	

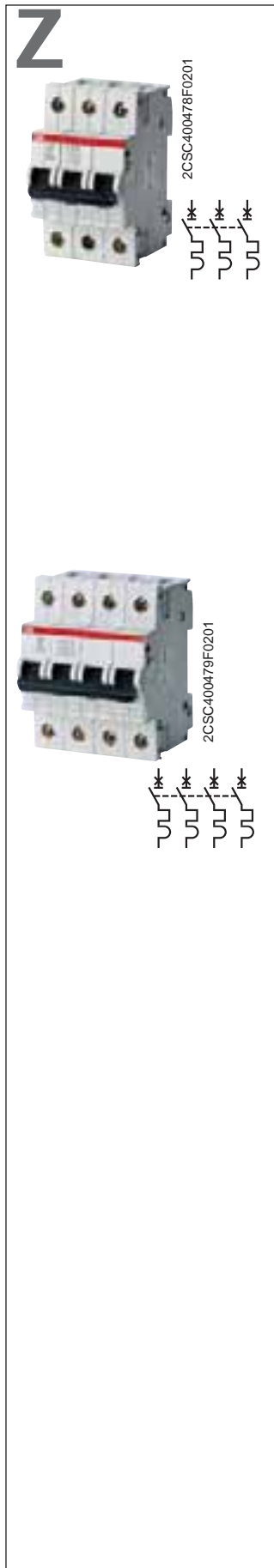

3	0.5	S 283 UC-Z 0.5	GHS2830164R0158	740000	0.390	3/12
	1	S 283 UC-Z 1	GHS2830164R0218	740109	0.390	3/12
	1.6	S 283 UC-Z 1.6	GHS2830164R0258	740208	0.390	3/12
	2	S 283 UC-Z 2	GHS2830164R0278	740307	0.390	3/12
	3	S 283 UC-Z 3	GHS2830164R0318	740406	0.390	3/12
	4	S 283 UC-Z 4	GHS2830164R0338	740505	0.390	3/12
	6	S 283 UC-Z 6	GHS2830164R0378	740604	0.390	3/12
	8	S 283 UC-Z 8	GHS2830164R0408	740703	0.390	3/12
	10	S 283 UC-Z 10	GHS2830164R0428	740802	0.390	3/12
	16	S 283 UC-Z 16	GHS2830164R0468	740901	0.390	3/12
	20	S 283 UC-Z 20	GHS2830164R0488	741007	0.390	3/12
	25	S 283 UC-Z 25	GHS2830164R0518	741106	0.390	3/12
	32	S 283 UC-Z 32	GHS2830164R0538	741205	0.390	3/12
	_UBmax	40	S 283 UC-Z 40	GHS2830164R0558	741304	0.390
440 V~	50	S 283 UC-Z 50	GHS2830164R0578	741403	0.480	3/12
440 V -...	63	S 283 UC-Z 63	GHS2830164R0608	741502	0.480	3/12

4	0.5	S 284 UC-Z 0.5	GHS2840164R0158	743605	0.520	2
	1	S 284 UC-Z 1	GHS2840164R0218	743704	0.520	2
	1.6	S 284 UC-Z 1.6	GHS2840164R0258	743803	0.520	2
	2	S 284 UC-Z 2	GHS2840164R0278	743902	0.520	2
	3	S 284 UC-Z 3	GHS2840164R0318	744008	0.520	2
	4	S 284 UC-Z 4	GHS2840164R0338	744107	0.520	2
	6	S 284 UC-Z 6	GHS2840164R0378	744206	0.520	2
	8	S 284 UC-Z 8	GHS2840164R0408	744305	0.520	2
	10	S 284 UC-Z 10	GHS2840164R0428	744404	0.520	2
	16	S 284 UC-Z 16	GHS2840164R0468	744503	0.520	2
	20	S 284 UC-Z 20	GHS2840164R0488	744602	0.520	2
	25	S 284 UC-Z 25	GHS2840164R0518	744701	0.520	2
	32	S 284 UC-Z 32	GHS2840164R0538	744800	0.520	2
	_UBmax	40	S 284 UC-Z 40	GHS2840164R0558	744909	0.520
440 V~	50	S 284 UC-Z 50	GHS2840164R0578	745005	0.640	2
440 V -...	63	S 284 UC-Z 63	GHS2840164R0608	745104	0.640	2



TECHNICAL FEATURES			S 290
Standards			IEC / EN 60898, IEC / EN 60947-2, UL 1077 ①
Rated current I _n		A	80 ≤ I _n ≤ 125
Poles			1P, 2P, 3P, 4P
Rated voltage U _e	IEC AC 1P	V	230-240
	IEC AC 2P, 3P, 4P	V	230/400-240/415
	UL AC 1P	V	277
	UL AC 2P, 3P, 4P	V	480 Y/277
Insulation voltage U _i		V	500
Max. operating voltage U _b max.	IEC AC	V	250/440
	UL AC 1P	V	480 Y/277
	IEC/UL DC 1P	V	60
	IEC/UL DC 2P, 3P, 4P	V	125
Min. operating voltage U _b min.		V	24VAC - 24VDC
Rated frequency		Hz	50...60
Rated breaking capacity acc. to IEC/EN 60898 ultimate I _{cn}		A	10000
Rated breaking capacity acc. to IEC/EN 60947-2 1P @ 230 VAC 2P, 3P, 4P @ 400 VAC	ultimate I _{cu}	kA	20 (15 for D characteristic)
	service I _{cs}	kA	10 (8 for D characteristic)
Rated interrupting capacity acc. to UL1077, CSA22.2 No.235 1P@277 VAC 2P,3P,4P@480 VAC	IR	kA (RMS)	5
Rated impulse withstand voltage (1.2/50) U _{imp}		kV	5
Dielectric test voltage at ind. freq. for 1 min.		kV	2.5
Overvoltage category			III
Thermomagnetic release characteristic	C: 5 I _n ≤ I _m ≤ 10 I _n		■
	D: 10 I _n ≤ I _m ≤ 20 I _n		■
	K: 10 I _n ≤ I _m ≤ 14 I _n		■
Toggle			black sealable in ON-OFF position
Electrical life			10000
Mechanical life			20000
Protection degree	housing		IP4X
	terminals		IP2X
Mechanical shock resistance			5 g, 2 impact shock, half wave form, duration 11 ms
Resistance to vibrations acc. to IEC/EN 60068-2-6			5 g - 20 cycles at frequency 5...150...5 Hz with load 0.8 In
Tropicalization acc. to IEC/EN 60068-2	humid heat	°C/RH	28 cycles with 55/95...100
	constant climatic conditions	°C/RH	23/83 - 40/93 - 55/20
	variable climatic conditions	°C/RH	25/95 - 40/95
Reference temperature for setting of thermal element		°C	30 (20 for characteristics K)
Ambient temperature (with daily average ≤ +35 °C)	IEC/UL	°C	-25...+45
Storage temperature		°C	-40...+70
Terminal type			cage (shock protected)
Terminal size top/bottom for cable	IEC	mm ²	50/50
	UL	AWG	14-1
Tightening torque	IEC	N*m	3.0...3.5
	UL	in-lbs.	35
Tool			No. 2 Posidriv
Mounting			on DIN rail EN 60715 (35 mm) by means of fast clip device
Connection			from top and bottom
Pole dimensions (H x D x W)		mm	90 x 70 x 26.25
Pole weight		g	258
Combinable with:	signal contact/auxiliary switch		yes
	shunt trip		yes
	undervoltage release		yes

① supplementary protection

10000

2

C

S 290 C characteristic

Function: protection and control of the circuits against overloads and short-circuits when high nominal currents are required; protection for resistive and inductive loads with low inrush current.

Applications: commercial and industrial.

Standard: IEC/EN 60898, IEC/EN 60947-2

I_{cn}=10 kA

Number of poles	Rated current In A	Order details Type code	Order code	Bbn 4016799	Price 1 piece	Price group	Weight 1 piece kg	Pack unit pc.
1	80	S291 C 80	GHS2912001R0804	570541			0.267	1/6
	100	S291 C100	GHS2912001R0824	570572			0.267	1/6
	125	S291 C125	GHS2912001R0844	570602			0.267	1/6

2	80	S292 C 80	GHS2922001R0804	570626			0.534	1/3
	100	S292 C100	GHS2922001R0824	570657			0.534	1/3
	125	S292 C125	GHS2922001R0844	570688			0.534	1/3

3	80	S293 C 80	GHS2932001R0804	570701			0.801	1/2
	100	S293 C100	GHS2932001R0824	570732			0.801	1/2
	125	S293 C125	GHS2932001R0844	570763			0.801	1/2

4	80	S294 C 80	GHS2942001R0804	570787			1.068	1
	100	S294 C100	GHS2942001R0824	570732			1.068	1
	125	S294 C125	GHS2942001R0844	570848			1.068	1



10000

D

S 290 D characteristic

Function: protection and control of the circuits against overloads and short-circuits when high nominal current are required; protection for circuits which supply loads with high inrush current at the circuit closing (motors, LV / LV transformers, breakdown lamps).

Applications: commercial and industrial.

Standard: IEC/EN 60898, IEC/EN 60947-2

Icn=10 kA

Number of poles	Rated current	Order details		Bbn 4016799	Price 1 piece	Price group	Weight 1 piece	Pack unit
	In A	Type code	Order code	EAN			kg	pc.
1	80	S291 D 80	GHS2912001R0801	120807			0.267	1/6
	100	S291 D100	GHS2912001R0821	120906			0.267	1/6
2	80	S292 D 80	GHS2922001R0801	121002			0.534	1/3
	100	S292 D100	GHS2922001R0821	121507			0.534	1/3
3	80	S293 D 80	GHS2932001R0801	121705			0.801	1/2
	100	S293 D100	GHS2932001R0821	121804			0.801	1/2
4	80	S294 D 80	GHS2942001R0801	121200			1.068	1
	100	S294 D100	GHS2942001R0821	121309			1.068	1



2CSC400020F0201



2CSC400010F0201



2CSC400011F0201

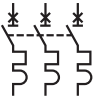

2CSC400012F0201



10000

K

S 290 K (power) characteristic

Function: protection and control of the circuits like motors, transformer and auxiliary circuits, against overloads and short-circuits when high nominal current are required.

Advantages: no nuisance tripping in the case of functional peak currents up to $8xI_n$, depending on the series; through its highly sensitive thermostatic bimetal trip, the K-type characteristic offers protection to damageable elements in the overcurrent range; it also provides the best protection to cables and lines.

Applications: commercial and industrial.

Standard: IEC/EN 60947-2, VDE 0660 Part 101

Icn=10 kA



2CSC400020F0201



2CSC400010F0201



2CSC400011F0201



2CSC400012F0201



Number of poles	Rated current	Order details	Bbn	Price	Price group	Weight	Pack unit
	In A	Type code	Order code	EAN		kg	pc.
1	80	S291 K 80	GHS2912001R0807	570558		0.267	1/6
	100	S291 K100	GHS2912001R0827	570589		0.267	1/6
2	80	S292 K 80	GHS2922001R0807	570633		0.534	1/3
	100	S292 K100	GHS2922001R0827	570664		0.534	1/3
3	80	S293 K 80	GHS2932001R0807	570718		0.801	1/2
	100	S293 K100	GHS2932001R0827	570749		0.801	1/2
4	80	S294 K 80	GHS2942001R0807	570794		1.068	1
	100	S294 K100	GHS2942001R0827	570824		1.068	1

2



TECHNICAL FEATURES	S800 S			
	B, C, D	K	KM	UCB, UCK
Characteristics available	B, C, D	K	KM	UCB, UCK
Max. rated continuous current I_n [A]	10...125	10...125	20...63	10...125
Poles	1...4	1...4	3	1...4
Rated operating voltage U_e				
(AC) 50/60Hz [V]	400/690	400/690	400/690	-
(DC)/pole [V]	-	-	-	250
Rated insulation voltage U_i [V]	690	690	690	250 ²
Rated impulse withstand voltage U_{imp} [kV]	8	8	8	8
Ultimate short-circuit breaking capacity I_{cu} in accordance with IEC 60947-2				
(AC) 50/60Hz 240/415V [kA]	50	50	50	-
(AC) 50/60Hz 254/440V (10...80A) [kA]	30	30	30	-
(AC) 50/60Hz 254/440V (100...125A) [kA]	30	30	30	-
(AC) 50/60Hz 289/500V (10...63A) [kA]	15	15	15	-
(AC) 50/60Hz 289/500V (80A) [kA]	15	15	15	-
(AC) 50/60Hz 289/500V (100...125A) [kA]	10	10	10	-
(AC) 50/60Hz 400/690V (10...80A) [kA]	6	6	6	-
(AC) 50/60Hz 400/690V (100...125A) [kA]	4.5	4.5	4.5	-
(DC) 250V (1-pole) [kA]	-	-	-	50
(DC) 500V (2-pole) [kA]	-	-	-	50
(DC) 750V (3-pole) [kA]	-	-	-	50
(DC) 750V (4-pole) [kA]	-	-	-	50
Rated short-circuit breaking capacity I_{cn} EN 60898-1				
(AC) 50/60Hz 240/415V (up to 80A) [kA]	25	-	-	-
Service short-circuit breaking capacity I_{cs} in accordance with IEC 60947-2				
(AC) 50/60Hz 240/415V [kA]	40	40	40	-
(AC) 50/60Hz 254/440V (10...80A) [kA]	22.5	22.5	22.5	-
(AC) 50/60Hz 254/440V (100...125A) [kA]	15	15	15	-
(AC) 50/60Hz 289/500V (10...63A) [kA]	11	11	11	-
(AC) 50/60Hz 289/500V (80A) [kA]	8	8	8	-
(AC) 50/60Hz 289/500V (100...125A) [kA]	5	5	5	-
(AC) 50/60Hz 400/690V (10...80A) [kA]	4	4	4	-
(AC) 50/60Hz 400/690V (100...125A) [kA]	3	3	3	-
(DC) 250V (1-pole) [kA]	-	-	-	50
(DC) 500V (2-pole) [kA]	-	-	-	50
(DC) 750V (3-pole) [kA]	-	-	-	50
(DC) 750V (4-pole) [kA]	-	-	-	50
Service short-circuit breaking capacity I_{cs} in accordance with EN 60898-1				
(AC) 50/60Hz 240/415V (up to 80A) [kA]	12.5	-	-	-
Rated frequency [Hz]	50/60, (16 2/3) ¹	50/60, (16 2/3) ¹	50/60	-
Total breaking time (240/415V; 50kA) [ms]			≤2.5	
Mounting position			any	
Disconnecter properties according to IEC 60947-2			yes	
Standards		IEC 60947-2		
Connections CU (10...32A) [mm ²]	EN 60898-1	-	-	-
	1...25 strand	1...25 strand	1...25 strand	1...25 strand
	1...35 cable	1...35 cable	1...35 cable	1...35 cable
Connections CU (40...125A) [mm ²]	6...50 strand	6...50 strand	6...50 strand	6...50 strand
	6...70 cable	6...70 cable	6...70 cable	6...70 cable
Tightening torque [Nm]		min. 3 / max. 4		
AC/DC supply		any		
Mounting on DIN top hat rail		EN 60715		
Permissible ambient temperature for operations [°C]		-25...+60		
Storage temperature [°C]		-40...+70		
Type of protection		IP20		
		IP40 (only actuation side)		
Classification in accordance with NF-16-101, NF16-102		I3F2		
Resistance to vibration		IEC 60068-2-27; IEC 60068-2; EN 61373 Cat.1/class B		



TECHNICAL FEATURES		S800 N
Characteristics available		B, C, D
Max. rated continuous current I_n	[A]	10...125
Poles		1...4
Rated operating voltage U_e		
(AC) 50/60Hz	[V]	400/690
(DC)/pole	[V]	-
Rated insulation voltage U_i	[V]	690
Rated impulse withstand voltage U_{imp}	[kV]	8
Ultimate short-circuit breaking capacity I_{cu} in accordance with IEC 60947-2		
(AC) 50/60Hz 240/415V	[kA]	36
(AC) 50/60Hz 254/440V (10...80A)	[kA]	20
(AC) 50/60Hz 254/440V (100...125A)	[kA]	20
(AC) 50/60Hz 289/500V (10...63A)	[kA]	10
(AC) 50/60Hz 289/500V (80A)	[kA]	10
(AC) 50/60Hz 289/500V (100...125A)	[kA]	10
(AC) 50/60Hz 400/690V (10...80A)	[kA]	4.5
(AC) 50/60Hz 400/690V (100...125A)	[kA]	4.5
Rated short-circuit breaking capacity I_{cn} EN 60898-1		
(AC) 50/60Hz 240/415V (up to 80A)	[kA]	25
Service short-circuit breaking capacity I_{cs} in accordance with IEC 60947-2		
(AC) 50/60Hz 240/415V	[kA]	30
(AC) 50/60Hz 254/440V (10...80A)	[kA]	15
(AC) 50/60Hz 254/440V (100...125A)	[kA]	10
(AC) 50/60Hz 289/500V (10...63A)	[kA]	8
(AC) 50/60Hz 289/500V (80A)	[kA]	5
(AC) 50/60Hz 289/500V (100...125A)	[kA]	5
(AC) 50/60Hz 400/690V (10...80A)	[kA]	3
(AC) 50/60Hz 400/690V (100...125A)	[kA]	3
Service short-circuit breaking capacity I_{cs} in accordance with EN 60898-1		
(AC) 50/60Hz 240/415V (up to 80A)	[kA]	12.5
Rated frequency	[Hz]	50/60
Total breaking time (240/415V; 50kA)	[ms]	≤2.5
Mounting position		any
Disconnecter properties according to IEC 60947-2		yes
Standards		IEC 60947-2 EN 60898-1
Connections CU (10...32A)	[mm ²]	1...25 strand 1...35 cable
Connections CU (40...125A)	[mm ²]	6...50 strand 6...70 cable
Tightening torque	[Nm]	min. 3 / max. 4
Supply AC		any
Mounting on DIN top hat rail		EN 60715
Permissible ambient temperature for operations	[°C]	-25...+60
Storage temperature	[°C]	-40...+70
Type of protection		IP20 IP40 (only actuation side)
Classification in accordance with NF-16-101, NF16-102		I3F2

B



S800 S-B characteristic

Function: protection and control of the circuits against overloads and short-circuits when a high breaking capacity is required; protection for people and big length cables in TN and IT systems; very useful when selectivity is needed vs an MCCB or back-up vs other MCBs wired downstream.

Applications: commercial and industrial.

Standard: IEC/EN 60898, IEC/EN 60947-2

Icn=25 kA

Icu=50 kA

Number of poles	Rated current	Order details	Bbn 7612271	Price 1 piece	Price group	Weight 1 piece	Pack unit
In A	Type code	Order code	EAN			kg	pc.
1	10	S801S-B10	2CCS861001R0105	200008		0.245	1
	13	S801S-B13	2CCS861001R0135	200015		0.245	1
	16	S801S-B16	2CCS861001R0165	200022		0.245	1
	20	S801S-B20	2CCS861001R0205	200039		0.245	1
	25	S801S-B25	2CCS861001R0255	200046		0.245	1
	32	S801S-B32	2CCS861001R0325	200053		0.245	1
	40	S801S-B40	2CCS861001R0405	200060		0.245	1
	50	S801S-B50	2CCS861001R0505	200077		0.245	1
	63	S801S-B63	2CCS861001R0635	200084		0.245	1
	80	S801S-B80	2CCS861001R0805	200091		0.245	1
	100	S801S-B100	2CCS861001R0825	200107		0.245	1
	125	S801S-B125	2CCS861001R0845	200114		0.245	1
2	10	S802S-B10	2CCS862001R0105	200121		0.49	1
	13	S802S-B13	2CCS862001R0135	200138		0.49	1
	16	S802S-B16	2CCS862001R0165	200145		0.49	1
	20	S802S-B20	2CCS862001R0205	200152		0.49	1
	25	S802S-B25	2CCS862001R0255	200169		0.49	1
	32	S802S-B32	2CCS862001R0325	200176		0.49	1
	40	S802S-B40	2CCS862001R0405	200183		0.49	1
	50	S802S-B50	2CCS862001R0505	200190		0.49	1
	63	S802S-B63	2CCS862001R0635	200206		0.49	1
	80	S802S-B80	2CCS862001R0805	200213		0.49	1
	100	S802S-B100	2CCS862001R0825	200220		0.49	1
	125	S802S-B125	2CCS862001R0845	200237		0.49	1
3	10	S803S-B10	2CCS863001R0105	200244		0.735	1
	13	S803S-B13	2CCS863001R0135	200251		0.735	1
	16	S803S-B16	2CCS863001R0165	200268		0.735	1
	20	S803S-B20	2CCS863001R0205	200275		0.735	1
	25	S803S-B25	2CCS863001R0255	200282		0.735	1
	32	S803S-B32	2CCS863001R0325	200299		0.735	1
	40	S803S-B40	2CCS863001R0405	200305		0.735	1
	50	S803S-B50	2CCS863001R0505	200312		0.735	1
	63	S803S-B63	2CCS863001R0635	200329		0.735	1
	80	S803S-B80	2CCS863001R0805	200336		0.735	1
	100	S803S-B100	2CCS863001R0825	200343		0.735	1
	125	S803S-B125	2CCS863001R0845	200350		0.735	1
4	10	S804S-B10	2CCS864001R0105	200367		0.98	1
	13	S804S-B13	2CCS864001R0135	200374		0.98	1
	16	S804S-B16	2CCS864001R0165	200381		0.98	1
	20	S804S-B20	2CCS864001R0205	200398		0.98	1
	25	S804S-B25	2CCS864001R0255	200404		0.98	1
	32	S804S-B32	2CCS864001R0325	200411		0.98	1
	40	S804S-B40	2CCS864001R0405	200428		0.98	1
	50	S804S-B50	2CCS864001R0505	200435		0.98	1
	63	S804S-B63	2CCS864001R0635	200442		0.98	1
	80	S804S-B80	2CCS864001R0805	200459		0.98	1
	100	S804S-B100	2CCS864001R0825	200466		0.98	1
	125	S804S-B125	2CCS864001R0845	200473		0.98	1

B

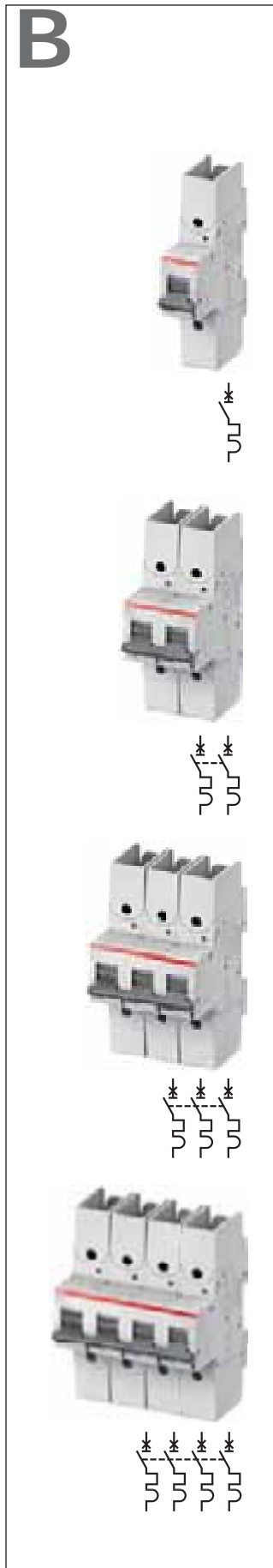

S800 S-B characteristic

Function: protection and control of the circuits against overloads and short-circuits when a high breaking capacity is required; protection for people and big length cables in TN and IT systems; very useful when selectivity is needed vs an MCCB or back-up vs other MCBs wired downstream.

Applications: commercial and industrial.

Standard: IEC/EN 60898, IEC/EN 60947-2

Icn=25 kA

Icu=50 kA

Number of poles	Rated current In A	Order details Type code	Order code	Bbn 7612271 EAN	Price 1 piece	Price group	Weight 1 piece kg	Pack unit pc.
1	10	S801S-B10-R	2CCS861002R0105	209636			0,245	1
	13	S801S-B13-R	2CCS861002R0135	209643			0,245	1
	16	S801S-B16-R	2CCS861002R0165	209650			0,245	1
	20	S801S-B20-R	2CCS861002R0205	209667			0,245	1
	25	S801S-B25-R	2CCS861002R0255	209674			0,245	1
	32	S801S-B32-R	2CCS861002R0325	209681			0,245	1
	40	S801S-B40-R	2CCS861002R0405	206826			0,245	1
	50	S801S-B50-R	2CCS861002R0505	206833			0,245	1
	63	S801S-B63-R	2CCS861002R0635	206840			0,245	1
	80	S801S-B80-R	2CCS861002R0805	206857			0,245	1
	100	S801S-B100-R	2CCS861002R0825	206864			0,245	1
	125	S801S-B125-R	2CCS861002R0845	206871			0,245	1
	2	10	S802S-B10-R	2CCS862002R0105	209698			0,49
13		S802S-B13-R	2CCS862002R0135	209704			0,49	1
16		S802S-B16-R	2CCS862002R0165	209711			0,49	1
20		S802S-B20-R	2CCS862002R0205	209728			0,49	1
25		S802S-B25-R	2CCS862002R0255	209735			0,49	1
32		S802S-B32-R	2CCS862002R0325	209742			0,49	1
40		S802S-B40-R	2CCS862002R0405	206888			0,49	1
50		S802S-B50-R	2CCS862002R0505	206895			0,49	1
63		S802S-B63-R	2CCS862002R0635	206901			0,49	1
80		S802S-B80-R	2CCS862002R0805	206918			0,49	1
100		S802S-B100-R	2CCS862002R0825	206925			0,49	1
125		S802S-B125-R	2CCS862002R0845	206932			0,49	1
3		10	S803S-B10-R	2CCS863002R0105	209759			0,735
	13	S803S-B13-R	2CCS863002R0135	209766			0,735	1
	16	S803S-B16-R	2CCS863002R0165	209773			0,735	1
	20	S803S-B20-R	2CCS863002R0205	209780			0,735	1
	25	S803S-B25-R	2CCS863002R0255	209797			0,735	1
	32	S803S-B32-R	2CCS863002R0325	209803			0,735	1
	40	S803S-B40-R	2CCS863002R0405	206949			0,735	1
	50	S803S-B50-R	2CCS863002R0505	206956			0,735	1
	63	S803S-B63-R	2CCS863002R0635	206963			0,735	1
	80	S803S-B80-R	2CCS863002R0805	206970			0,735	1
	100	S803S-B100-R	2CCS863002R0825	206987			0,735	1
	125	S803S-B125-R	2CCS863002R0845	206994			0,735	1
	4	10	S804S-B10-R	2CCS864002R0105	209810			0,98
13		S804S-B13-R	2CCS864002R0135	209827			0,98	1
16		S804S-B16-R	2CCS864002R0165	209834			0,98	1
20		S804S-B20-R	2CCS864002R0205	209841			0,98	1
25		S804S-B25-R	2CCS864002R0255	209858			0,98	1
32		S804S-B32-R	2CCS864002R0325	209865			0,98	1
40		S804S-B40-R	2CCS864002R0405	207007			0,98	1
50		S804S-B50-R	2CCS864002R0505	207014			0,98	1
63		S804S-B63-R	2CCS864002R0635	207021			0,98	1
80		S804S-B80-R	2CCS864002R0805	207038			0,98	1
100		S804S-B100-R	2CCS864002R0825	207045			0,98	1
125		S804S-B125-R	2CCS864002R0845	207052			0,98	1

C



S800 S-C characteristic

Function: protection and control of the circuits against overloads and short-circuits when a high breaking capacity is required; protection for resistive and inductive loads with low inrush current; very useful when selectivity is needed vs an MCCB or back-up vs other MCBs wired downstream.

Applications: commercial and industrial.

Standard: IEC/EN 60898, IEC/EN 60947-2

Icn=25 kA

Icu=50 kA

Number of poles	Rated current	Order details	Bbn 7612271	Price 1 piece	Price group	Weight 1 piece	Pack unit
	In A	Type code	Order code	EAN		kg	pc.
1	10	S801S-C10	2CCS861001R0104	200480		0.245	1
	13	S801S-C13	2CCS861001R0134	200497		0.245	1
	16	S801S-C16	2CCS861001R0164	200503		0.245	1
	20	S801S-C20	2CCS861001R0204	200510		0.245	1
	25	S801S-C25	2CCS861001R0254	200527		0.245	1
	32	S801S-C32	2CCS861001R0324	200534		0.245	1
	40	S801S-C40	2CCS861001R0404	200541		0.245	1
	50	S801S-C50	2CCS861001R0504	200558		0.245	1
	63	S801S-C63	2CCS861001R0634	200565		0.245	1
	80	S801S-C80	2CCS861001R0804	200572		0.245	1
	100	S801S-C100	2CCS861001R0824	200589		0.245	1
	125	S801S-C125	2CCS861001R0844	200596		0.245	1
2	10	S802S-C10	2CCS862001R0104	200602		0.49	1
	13	S802S-C13	2CCS862001R0134	200619		0.49	1
	16	S802S-C16	2CCS862001R0164	200626		0.49	1
	20	S802S-C20	2CCS862001R0204	200633		0.49	1
	25	S802S-C25	2CCS862001R0254	200640		0.49	1
	32	S802S-C32	2CCS862001R0324	200657		0.49	1
	40	S802S-C40	2CCS862001R0404	200664		0.49	1
	50	S802S-C50	2CCS862001R0504	200671		0.49	1
	63	S802S-C63	2CCS862001R0634	200688		0.49	1
	80	S802S-C80	2CCS862001R0804	200695		0.49	1
	100	S802S-C100	2CCS862001R0824	200701		0.49	1
	125	S802S-C125	2CCS862001R0844	200718		0.49	1
3	10	S803S-C10	2CCS863001R0104	200725		0.735	1
	13	S803S-C13	2CCS863001R0134	200732		0.735	1
	16	S803S-C16	2CCS863001R0164	200749		0.735	1
	20	S803S-C20	2CCS863001R0204	200756		0.735	1
	25	S803S-C25	2CCS863001R0254	200763		0.735	1
	32	S803S-C32	2CCS863001R0324	200770		0.735	1
	40	S803S-C40	2CCS863001R0404	200787		0.735	1
	50	S803S-C50	2CCS863001R0504	200794		0.735	1
	63	S803S-C63	2CCS863001R0634	200800		0.735	1
	80	S803S-C80	2CCS863001R0804	200817		0.735	1
	100	S803S-C100	2CCS863001R0824	200824		0.735	1
	125	S803S-C125	2CCS863001R0844	200831		0.735	1
4	10	S804S-C10	2CCS864001R0104	200848		0.98	1
	13	S804S-C13	2CCS864001R0134	200855		0.98	1
	16	S804S-C16	2CCS864001R0164	200862		0.98	1
	20	S804S-C20	2CCS864001R0204	200879		0.98	1
	25	S804S-C25	2CCS864001R0254	200886		0.98	1
	32	S804S-C32	2CCS864001R0324	200893		0.98	1
	40	S804S-C40	2CCS864001R0404	200909		0.98	1
	50	S804S-C50	2CCS864001R0504	200916		0.98	1
	63	S804S-C63	2CCS864001R0634	200923		0.98	1
	80	S804S-C80	2CCS864001R0804	200930		0.98	1
	100	S804S-C100	2CCS864001R0824	200947		0.98	1
	125	S804S-C125	2CCS864001R0844	200954		0.98	1

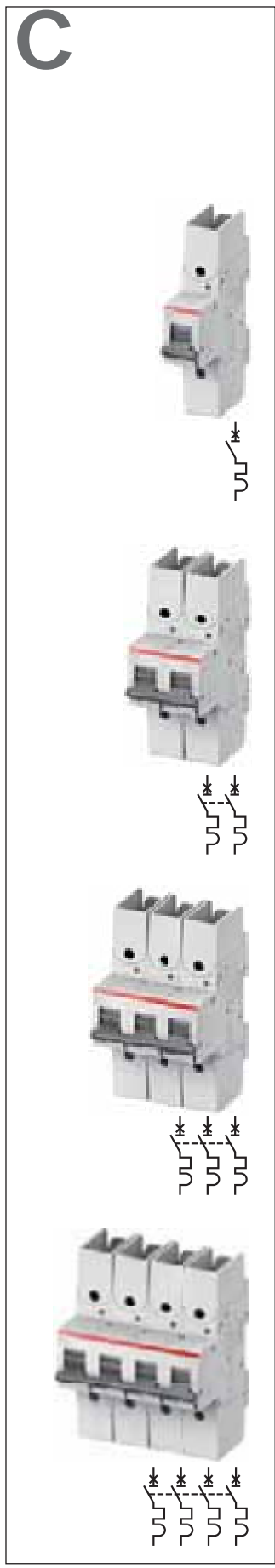

S800 S-C characteristic

Function: protection and control of the circuits against overloads and short-circuits when a high breaking capacity is required; protection for resistive and inductive loads with low inrush current; very useful when selectivity is needed vs an MCCB or back-up vs other MCBs wired downstream.

Applications: commercial and industrial.

Standard: IEC/EN 60947-2, VDE 0660 Part 101

Icn=25 kA

Icu=50 kA

Number of poles	Rated current In A	Order details Type code	Order code	Bbn 7612271 EAN	Price 1 piece	Price group	Weight 1 piece kg	Pack unit pc.
1	10	S801S-C10-R	2CCS861002R0104	209872			0,245	1
	13	S801S-C13-R	2CCS861002R0134	209889			0,245	1
	16	S801S-C16-R	2CCS861002R0164	209896			0,245	1
	20	S801S-C20-R	2CCS861002R0204	209902			0,245	1
	25	S801S-C25-R	2CCS861002R0254	209919			0,245	1
	32	S801S-C32-R	2CCS861002R0324	209926			0,245	1
	40	S801S-C40-R	2CCS861002R0404	207069			0,245	1
	50	S801S-C50-R	2CCS861002R0504	207076			0,245	1
	63	S801S-C63-R	2CCS861002R0634	207083			0,245	1
	80	S801S-C80-R	2CCS861002R0804	207090			0,245	1
	100	S801S-C100-R	2CCS861002R0824	207106			0,245	1
	125	S801S-C125-R	2CCS861002R0844	207113			0,245	1
	2	10	S802S-C10-R	2CCS862002R0104	209933			0,49
13		S802S-C13-R	2CCS862002R0134	209940			0,49	1
16		S802S-C16-R	2CCS862002R0164	209957			0,49	1
20		S802S-C20-R	2CCS862002R0204	209964			0,49	1
25		S802S-C25-R	2CCS862002R0254	209971			0,49	1
32		S802S-C32-R	2CCS862002R0324	209988			0,49	1
40		S802S-C40-R	2CCS862002R0404	207120			0,49	1
50		S802S-C50-R	2CCS862002R0504	207137			0,49	1
63		S802S-C63-R	2CCS862002R0634	207144			0,49	1
80		S802S-C80-R	2CCS862002R0804	207151			0,49	1
100		S802S-C100-R	2CCS862002R0824	207168			0,49	1
125		S802S-C125-R	2CCS862002R0844	207175			0,49	1
3		10	S803S-C10-R	2CCS863002R0104	209995			0,735
	13	S803S-C13-R	2CCS863002R0134	210007			0,735	1
	16	S803S-C16-R	2CCS863002R0164	210014			0,735	1
	20	S803S-C20-R	2CCS863002R0204	210021			0,735	1
	25	S803S-C25-R	2CCS863002R0254	210038			0,735	1
	32	S803S-C32-R	2CCS863002R0324	210045			0,735	1
	40	S803S-C40-R	2CCS863002R0404	207182			0,735	1
	50	S803S-C50-R	2CCS863002R0504	207199			0,735	1
	63	S803S-C63-R	2CCS863002R0634	207205			0,735	1
	80	S803S-C80-R	2CCS863002R0804	207212			0,735	1
	100	S803S-C100-R	2CCS863002R0824	207229			0,735	1
	125	S803S-C125-R	2CCS863002R0844	207236			0,735	1
	4	10	S804S-C10-R	2CCS864002R0104	210052			0,98
13		S804S-C13-R	2CCS864002R0134	210069			0,98	1
16		S804S-C16-R	2CCS864002R0164	210076			0,98	1
20		S804S-C20-R	2CCS864002R0204	210083			0,98	1
25		S804S-C25-R	2CCS864002R0254	210090			0,98	1
32		S804S-C32-R	2CCS864002R0324	210106			0,98	1
40		S804S-C40-R	2CCS864002R0404	207243			0,98	1
50		S804S-C50-R	2CCS864002R0504	207250			0,98	1
63		S804S-C63-R	2CCS864002R0634	207267			0,98	1
80		S804S-C80-R	2CCS864002R0804	207274			0,98	1
100		S804S-C100-R	2CCS864002R0824	207281			0,98	1
125		S804S-C125-R	2CCS864002R0844	207298			0,98	1

D



S800 S-D characteristic

Function: protection and control of the circuits against overloads and short-circuits when a high breaking capacity is required; protection for circuits which supply loads with high inrush current at the circuit closing (motors, LV / LV transformers, breakdown lamps); very useful when selectivity is needed vs an MCCB or back-up vs other MCBs wired downstream.

Applications: commercial and industrial.

Standard: IEC/EN 60898, IEC/EN 60947-2

I_{cn}=25 kA

I_{cu}=50 kA

Number of poles	Rated current	Order details	Bbn 7612271	Price 1 piece	Price group	Weight 1 piece	Pack unit
In A	Type code	Order code	EAN			kg	pc.
1	10	S801S-D10	2CCS861001R0101	200961		0.245	1
	13	S801S-D13	2CCS861001R0131	200978		0.245	1
	16	S801S-D16	2CCS861001R0161	200985		0.245	1
	20	S801S-D20	2CCS861001R0201	200992		0.245	1
	25	S801S-D25	2CCS861001R0251	201005		0.245	1
	32	S801S-D32	2CCS861001R0321	201012		0.245	1
	40	S801S-D40	2CCS861001R0401	201029		0.245	1
	50	S801S-D50	2CCS861001R0501	201036		0.245	1
	63	S801S-D63	2CCS861001R0631	201043		0.245	1
	80	S801S-D80	2CCS861001R0801	201050		0.245	1
	100	S801S-D100	2CCS861001R0821	201067		0.245	1
	125	S801S-D125	2CCS861001R0841	201074		0.245	1
2	10	S802S-D10	2CCS862001R0101	201081		0.49	1
	13	S802S-D13	2CCS862001R0131	201098		0.49	1
	16	S802S-D16	2CCS862001R0161	201104		0.49	1
	20	S802S-D20	2CCS862001R0201	201111		0.49	1
	25	S802S-D25	2CCS862001R0251	201128		0.49	1
	32	S802S-D32	2CCS862001R0321	201135		0.49	1
	40	S802S-D40	2CCS862001R0401	201142		0.49	1
	50	S802S-D50	2CCS862001R0501	201159		0.49	1
	63	S802S-D63	2CCS862001R0631	201166		0.49	1
	80	S802S-D80	2CCS862001R0801	201173		0.49	1
	100	S802S-D100	2CCS862001R0821	201180		0.49	1
	125	S802S-D125	2CCS862001R0841	201197		0.49	1
3	10	S803S-D10	2CCS863001R0101	201203		0.735	1
	13	S803S-D13	2CCS863001R0131	201210		0.735	1
	16	S803S-D16	2CCS863001R0161	201227		0.735	1
	20	S803S-D20	2CCS863001R0201	201234		0.735	1
	25	S803S-D25	2CCS863001R0251	201241		0.735	1
	32	S803S-D32	2CCS863001R0321	201258		0.735	1
	40	S803S-D40	2CCS863001R0401	201265		0.735	1
	50	S803S-D50	2CCS863001R0501	201272		0.735	1
	63	S803S-D63	2CCS863001R0631	201289		0.735	1
	80	S803S-D80	2CCS863001R0801	201296		0.735	1
	100	S803S-D100	2CCS863001R0821	201302		0.735	1
	125	S803S-D125	2CCS863001R0841	201319		0.735	1
4	10	S804S-D10	2CCS864001R0101	201326		0.98	1
	13	S804S-D13	2CCS864001R0131	201333		0.98	1
	16	S804S-D16	2CCS864001R0161	201340		0.98	1
	20	S804S-D20	2CCS864001R0201	201357		0.98	1
	25	S804S-D25	2CCS864001R0251	201364		0.98	1
	32	S804S-D32	2CCS864001R0321	201371		0.98	1
	40	S804S-D40	2CCS864001R0401	201388		0.98	1
	50	S804S-D50	2CCS864001R0501	201395		0.98	1
	63	S804S-D63	2CCS864001R0631	201401		0.98	1
	80	S804S-D80	2CCS864001R0801	201418		0.98	1
	100	S804S-D100	2CCS864001R0821	201425		0.98	1
	125	S804S-D125	2CCS864001R0841	201432		0.98	1

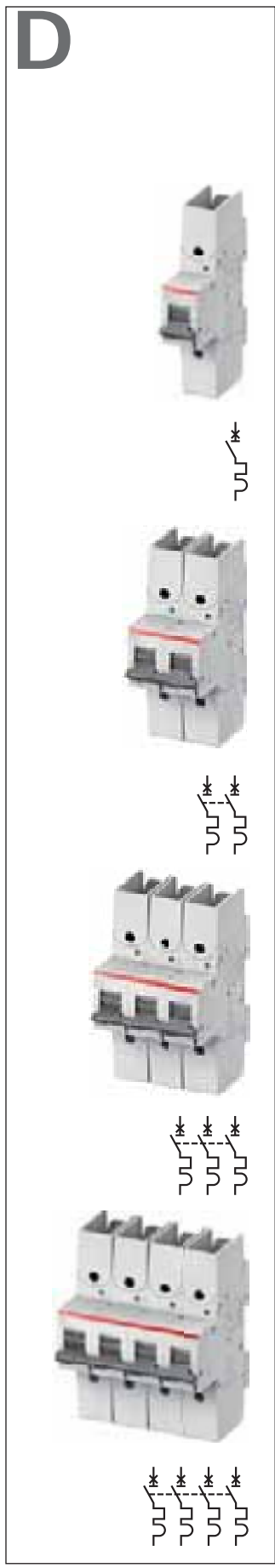

S800 S-D characteristic

Function: protection and control of the circuits against overloads and short-circuits when a high breaking capacity is required; protection for circuits which supply loads with high inrush current at the circuit closing (motors, LV / LV transformers, breakdown lamps); very useful when selectivity is needed vs an MCCB or back-up vs other MCBs wired downstream.

Applications: commercial and industrial.

Standard: IEC/EN 60947-2, VDE 0660 Part 101

Icn=25 kA

Icu=50 kA

Number of poles	Rated current In A	Order details	Order code	Bbn 7612271	Price 1 piece	Price group	Weight 1 piece kg	Pack unit pc.	
1	10	S801S-D10-R	2CCS861002R0101	210113			0,245	1	
	13	S801S-D13-R	2CCS861002R0131	210120			0,245	1	
	16	S801S-D16-R	2CCS861002R0161	210137			0,245	1	
	20	S801S-D20-R	2CCS861002R0201	210144			0,245	1	
	25	S801S-D25-R	2CCS861002R0251	210151			0,245	1	
	32	S801S-D32-R	2CCS861002R0321	210168			0,245	1	
	40	S801S-D40-R	2CCS861002R0401	207304			0,245	1	
	50	S801S-D50-R	2CCS861002R0501	207311			0,245	1	
	63	S801S-D63-R	2CCS861002R0631	207328			0,245	1	
	80	S801S-D80-R	2CCS861002R0801	207335			0,245	1	
	100	S801S-D100-R	2CCS861002R0821	207342			0,245	1	
	125	S801S-D125-R	2CCS861002R0841	207359			0,245	1	
	2	10	S802S-D10-R	2CCS862002R0101	210175			0,49	1
		13	S802S-D13-R	2CCS862002R0131	210182			0,49	1
16		S802S-D16-R	2CCS862002R0161	210199			0,49	1	
20		S802S-D20-R	2CCS862002R0201	210205			0,49	1	
25		S802S-D25-R	2CCS862002R0251	210212			0,49	1	
32		S802S-D32-R	2CCS862002R0321	210229			0,49	1	
40		S802S-D40-R	2CCS862002R0401	207366			0,49	1	
50		S802S-D50-R	2CCS862002R0501	207373			0,49	1	
63		S802S-D63-R	2CCS862002R0631	207380			0,49	1	
80		S802S-D80-R	2CCS862002R0801	207397			0,49	1	
100		S802S-D100-R	2CCS862002R0821	207403			0,49	1	
125		S802S-D125-R	2CCS862002R0841	207410			0,49	1	
3		10	S803S-D10-R	2CCS863002R0101	210236			0,735	1
		13	S803S-D13-R	2CCS863002R0131	210243			0,735	1
	16	S803S-D16-R	2CCS863002R0161	210250			0,735	1	
	20	S803S-D20-R	2CCS863002R0201	210267			0,735	1	
	25	S803S-D25-R	2CCS863002R0251	210274			0,735	1	
	32	S803S-D32-R	2CCS863002R0321	210281			0,735	1	
	40	S803S-D40-R	2CCS863002R0401	207427			0,735	1	
	50	S803S-D50-R	2CCS863002R0501	207434			0,735	1	
	63	S803S-D63-R	2CCS863002R0631	207441			0,735	1	
	80	S803S-D80-R	2CCS863002R0801	207458			0,735	1	
	100	S803S-D100-R	2CCS863002R0821	207465			0,735	1	
	125	S803S-D125-R	2CCS863002R0841	207472			0,735	1	
	4	10	S804S-D10-R	2CCS864002R0101	210298			0,98	1
		13	S804S-D13-R	2CCS864002R0131	210304			0,98	1
16		S804S-D16-R	2CCS864002R0161	210311			0,98	1	
20		S804S-D20-R	2CCS864002R0201	210328			0,98	1	
25		S804S-D25-R	2CCS864002R0251	210335			0,98	1	
32		S804S-D32-R	2CCS864002R0321	210342			0,98	1	
40		S804S-D40-R	2CCS864002R0401	207489			0,98	1	
50		S804S-D50-R	2CCS864002R0501	207496			0,98	1	
63		S804S-D63-R	2CCS864002R0631	207502			0,98	1	
80		S804S-D80-R	2CCS864002R0801	207519			0,98	1	
100		S804S-D100-R	2CCS864002R0821	207526			0,98	1	
125		S804S-D125-R	2CCS864002R0841	207533			0,98	1	

K



S800 S-K characteristic

Function: protection and control of the circuits like motors, transformer and auxiliary circuits, against overloads and short-circuits when a high breaking capacity is required; very useful when selectivity is needed vs an MCCB or back-up vs other MCBs wired downstream.

Advantages: no nuisance tripping in the case of functional peak currents up to 10xIn, depending on the series; through its highly sensitive thermostatic bimetal trip, the K-type characteristic offers protection to damageable elements in the overcurrent range; it also provides the best protection to cables and lines.

Applications: commercial and industrial.

Standard: IEC/EN 60947-2

Icu=50 kA

Number of poles	Rated current In A	Order details	Order code	Bbn 7612271	Price 1 piece	Price group	Weight 1 piece kg	Pack unit pc.
1	10	S801S-K10	2CCS861001R0427	201449			0.245	1
	13	S801S-K13	2CCS861001R0447	201456			0.245	1
	16	S801S-K16	2CCS861001R0467	201463			0.245	1
	20	S801S-K20	2CCS861001R0487	201470			0.245	1
	25	S801S-K25	2CCS861001R0517	201487			0.245	1
	32	S801S-K32	2CCS861001R0537	201494			0.245	1
	40	S801S-K40	2CCS861001R0557	201500			0.245	1
	50	S801S-K50	2CCS861001R0577	201517			0.245	1
	63	S801S-K63	2CCS861001R0597	201524			0.245	1
	80	S801S-K80	2CCS861001R0627	201531			0.245	1
	100	S801S-K100	2CCS861001R0637	201548			0.245	1
	125	S801S-K125	2CCS861001R0647	201555			0.245	1
	2	10	S802S-K10	2CCS862001R0427	201562			0.49
13		S802S-K13	2CCS862001R0447	201579			0.49	1
16		S802S-K16	2CCS862001R0467	201586			0.49	1
20		S802S-K20	2CCS862001R0487	201593			0.49	1
25		S802S-K25	2CCS862001R0517	201609			0.49	1
32		S802S-K32	2CCS862001R0537	201616			0.49	1
40		S802S-K40	2CCS862001R0557	201623			0.49	1
50		S802S-K50	2CCS862001R0577	201630			0.49	1
63		S802S-K63	2CCS862001R0597	201647			0.49	1
80		S802S-K80	2CCS862001R0627	201654			0.49	1
100		S802S-K100	2CCS862001R0637	201661			0.49	1
125		S802S-K125	2CCS862001R0647	201678			0.49	1
3		10	S803S-K10	2CCS863001R0427	201685			0.735
	13	S803S-K13	2CCS863001R0447	201692			0.735	1
	16	S803S-K16	2CCS863001R0467	201708			0.735	1
	20	S803S-K20	2CCS863001R0487	201715			0.735	1
	25	S803S-K25	2CCS863001R0517	201722			0.735	1
	32	S803S-K32	2CCS863001R0537	201739			0.735	1
	40	S803S-K40	2CCS863001R0557	201746			0.735	1
	50	S803S-K50	2CCS863001R0577	201753			0.735	1
	63	S803S-K63	2CCS863001R0597	201760			0.735	1
	80	S803S-K80	2CCS863001R0627	201777			0.735	1
	100	S803S-K100	2CCS863001R0637	201784			0.735	1
	125	S803S-K125	2CCS863001R0647	201791			0.735	1
	4	10	S804S-K10	2CCS864001R0427	201807			0.98
13		S804S-K13	2CCS864001R0447	201814			0.98	1
16		S804S-K16	2CCS864001R0467	201821			0.98	1
20		S804S-K20	2CCS864001R0487	201838			0.98	1
25		S804S-K25	2CCS864001R0517	201845			0.98	1
32		S804S-K32	2CCS864001R0537	201852			0.98	1
40		S804S-K40	2CCS864001R0557	201869			0.98	1
50		S804S-K50	2CCS864001R0577	201876			0.98	1
63		S804S-K63	2CCS864001R0597	201883			0.98	1
80		S804S-K80	2CCS864001R0627	201890			0.98	1
100		S804S-K100	2CCS864001R0637	201906			0.98	1
125		S804S-K125	2CCS864001R0647	201913			0.98	1

K

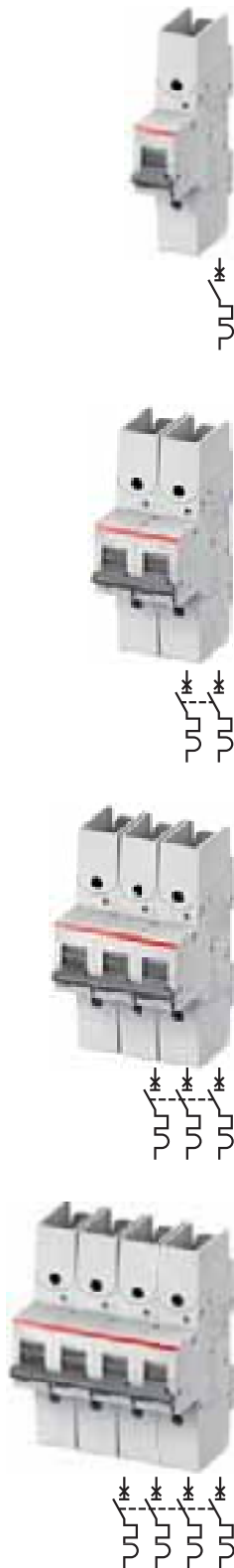

S800 S-K characteristic

Function: protection and control of the circuits like motors, transformer and auxiliary circuits, against overloads and short-circuits when a high breaking capacity is required; very useful when selectivity is needed vs an MCCB or back-up vs other MCBs wired downstream.

Advantages: no nuisance tripping in the case of functional peak currents up to 10xIn, depending on the series; through its highly sensitive thermostatic bimetal trip, the K-type characteristic offers protection to damageable elements in the overcurrent range; it also provides the best protection to cables and lines.

Applications: commercial and industrial.

Standard: IEC/EN 60947-2, VDE 0660 Part 101

Icu=50 kA

Number of poles	Rated current In A	Order details Type code	Order code	Bbn 7612271 EAN	Price 1 piece	Price group	Weight 1 piece kg	Pack unit pc.
1	10	S801S-K10-R	2CCS861002R0427	209391			0,245	1
	13	S801S-K13-R	2CCS861002R0447	209407			0,245	1
	16	S801S-K16-R	2CCS861002R0467	209414			0,245	1
	20	S801S-K20-R	2CCS861002R0487	209421			0,245	1
	25	S801S-K25-R	2CCS861002R0517	209438			0,245	1
	32	S801S-K32-R	2CCS861002R0537	209445			0,245	1
	40	S801S-K40-R	2CCS861002R0557	207540			0,245	1
	50	S801S-K50-R	2CCS861002R0577	207557			0,245	1
	63	S801S-K63-R	2CCS861002R0597	207564			0,245	1
	80	S801S-K80-R	2CCS861002R0627	207571			0,245	1
	100	S801S-K100-R	2CCS861002R0637	207588			0,245	1
	125	S801S-K125-R	2CCS861002R0647	207595			0,245	1
	2	10	S802S-K10-R	2CCS862002R0427	209452			0,49
13		S802S-K13-R	2CCS862002R0447	209469			0,49	1
16		S802S-K16-R	2CCS862002R0467	209476			0,49	1
20		S802S-K20-R	2CCS862002R0487	209483			0,49	1
25		S802S-K25-R	2CCS862002R0517	209490			0,49	1
32		S802S-K32-R	2CCS862002R0537	209506			0,49	1
40		S802S-K40-R	2CCS862002R0557	207601			0,49	1
50		S802S-K50-R	2CCS862002R0577	207618			0,49	1
63		S802S-K63-R	2CCS862002R0597	207625			0,49	1
80		S802S-K80-R	2CCS862002R0627	207632			0,49	1
100		S802S-K100-R	2CCS862002R0637	207649			0,49	1
125		S802S-K125-R	2CCS862002R0647	207656			0,49	1
3		10	S803S-K10-R	2CCS863002R0427	209513			0,735
	13	S803S-K13-R	2CCS863002R0447	209520			0,735	1
	16	S803S-K16-R	2CCS863002R0467	209537			0,735	1
	20	S803S-K20-R	2CCS863002R0487	209544			0,735	1
	25	S803S-K25-R	2CCS863002R0517	209551			0,735	1
	32	S803S-K32-R	2CCS863002R0537	209568			0,735	1
	40	S803S-K40-R	2CCS863002R0557	207663			0,735	1
	50	S803S-K50-R	2CCS863002R0577	207670			0,735	1
	63	S803S-K63-R	2CCS863002R0597	207687			0,735	1
	80	S803S-K80-R	2CCS863002R0627	207694			0,735	1
	100	S803S-K100-R	2CCS863002R0637	207700			0,735	1
	125	S803S-K125-R	2CCS863002R0647	207717			0,735	1
	4	10	S804S-K10-R	2CCS864002R0427	209575			0,98
13		S804S-K13-R	2CCS864002R0447	209582			0,98	1
16		S804S-K16-R	2CCS864002R0467	209599			0,98	1
20		S804S-K20-R	2CCS864002R0487	209605			0,98	1
25		S804S-K25-R	2CCS864002R0517	209612			0,98	1
32		S804S-K32-R	2CCS864002R0537	209629			0,98	1
40		S804S-K40-R	2CCS864002R0557	207724			0,98	1
50		S804S-K50-R	2CCS864002R0577	207731			0,98	1
63		S804S-K63-R	2CCS864002R0597	207748			0,98	1
80		S804S-K80-R	2CCS864002R0627	207755			0,98	1
100		S804S-K100-R	2CCS864002R0637	207762			0,98	1
125		S804S-K125-R	2CCS864002R0647	207779			0,98	1

2

KM



S800 S-KM characteristic with cage terminal

Function: protection and control of the circuits against overloads and short-circuits when a high breaking capacity is required; only magnetic version dedicated to protect motors; very useful when selectivity is needed vs an MCCB or back-up vs other MCBs wired downstream; version dedicated to application in direct current circuits.

Applications: commercial and industrial.

Standard: IEC/EN 60947-2

I_{cu}=50 kA

Number of poles	Rated current	Order details	Bbn	Price	Price group	Weight	Pack unit
	In A	Type code	Order code	EAN		kg	pc.
3	20	S803S-KM20	2CCS863001R0486	202194		0.735	1
	25	S803S-KM25	2CCS863001R0516	202200		0.735	1
	32	S803S-KM32	2CCS863001R0536	202217		0.735	1
	40	S803S-KM40	2CCS863001R0556	202224		0.735	1
	50	S803S-KM50	2CCS863001R0576	202231		0.735	1
	63	S803S-KM63	2CCS863001R0596	202248		0.735	1

KM-R



S800 S-KM-R characteristic with ring terminal cable connection

Function: protection and control of the circuits against overloads and short-circuits when a high breaking capacity is required; only magnetic version dedicated to protect motors; very useful when selectivity is needed vs an MCCB or back-up vs other MCBs wired downstream; version dedicated to application in direct current circuits.

Applications: commercial and industrial.

Standard: IEC/EN 60947-2, VDE 0660 Part 101

I_{cu}=50 kA

Number of poles	Rated current	Order details	Bbn	Price	Price group	Weight	Pack unit
	In A	Type code	Order code	EAN		kg	pc.
3	20	S803S-KM20-R	2CCS863002R0486	210830		0,735	1
	25	S803S-KM25-R	2CCS863002R0516	210847		0,735	1
	32	S803S-KM32-R	2CCS863002R0536	210854		0,735	1
	40	S803S-KM40-R	2CCS863002R0556	207786		0,735	1
	50	S803S-KM50-R	2CCS863002R0576	207793		0,735	1
	63	S803S-KM63-R	2CCS863002R0596	207809		0,735	1

B

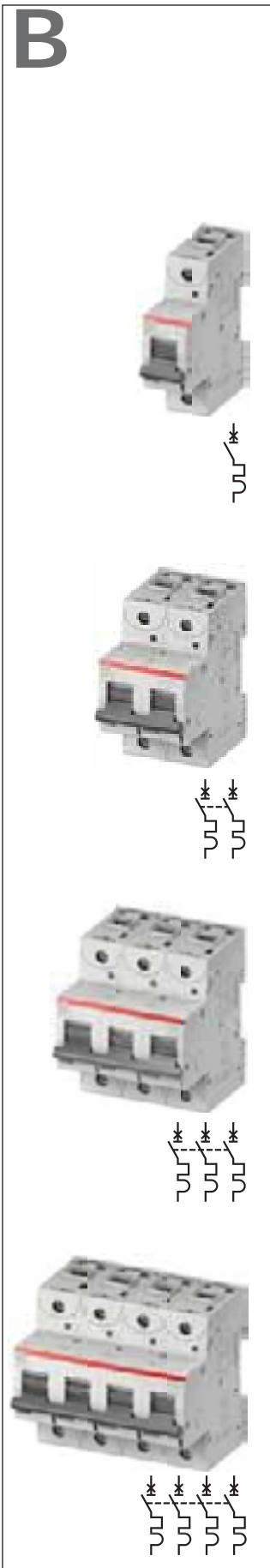

S800 S-UC B characteristic

Function: protection and control of the circuits against overloads and short-circuits when a high breaking capacity is required; protection for people and big length cables in TN and IT systems; very useful when selectivity is needed vs an MCCB or back-up vs other MCBs wired downstream; version dedicated to application in direct current circuits.

Applications: commercial and industrial.

Standard: IEC/EN 60947-2

Icu=50 kA

Number of poles	Rated current In A	Order details	Bbn 7612271	Price 1 piece	Price group	Weight 1 piece kg	Pack unit pc.
		Type code	Order code	EAN			
1	10	S801S-UCB10	2CCS861001R1105	202842		0.245	1
	13	S801S-UCB13	2CCS861001R1135	202859		0.245	1
	16	S801S-UCB16	2CCS861001R1165	202866		0.245	1
	20	S801S-UCB20	2CCS861001R1205	202873		0.245	1
	25	S801S-UCB25	2CCS861001R1255	202880		0.245	1
	32	S801S-UCB32	2CCS861001R1325	202897		0.245	1
	40	S801S-UCB40	2CCS861001R1405	202903		0.245	1
	50	S801S-UCB50	2CCS861001R1505	202910		0.245	1
	63	S801S-UCB63	2CCS861001R1635	202927		0.245	1
	80	S801S-UCB80	2CCS861001R1805	202934		0.245	1
	100	S801S-UCB100	2CCS861001R1825	202941		0.245	1
	125	S801S-UCB125	2CCS861001R1845	202958		0.245	1
	2	10	S802S-UCB10	2CCS862001R1105	202965		0.49
13		S802S-UCB13	2CCS862001R1135	202972		0.49	1
16		S802S-UCB16	2CCS862001R1165	202989		0.49	1
20		S802S-UCB20	2CCS862001R1205	202996		0.49	1
25		S802S-UCB25	2CCS862001R1255	203009		0.49	1
32		S802S-UCB32	2CCS862001R1325	203016		0.49	1
40		S802S-UCB40	2CCS862001R1405	203023		0.49	1
50		S802S-UCB50	2CCS862001R1505	203030		0.49	1
63		S802S-UCB63	2CCS862001R1635	203047		0.49	1
80		S802S-UCB80	2CCS862001R1805	203054		0.49	1
100		S802S-UCB100	2CCS862001R1825	203061		0.49	1
125		S802S-UCB125	2CCS862001R1845	203078		0.49	1
3		10	S803S-UCB10	2CCS863001R1105	203085		0.735
	13	S803S-UCB13	2CCS863001R1135	203092		0.735	1
	16	S803S-UCB16	2CCS863001R1165	203108		0.735	1
	20	S803S-UCB20	2CCS863001R1205	203115		0.735	1
	25	S803S-UCB25	2CCS863001R1255	203122		0.735	1
	32	S803S-UCB32	2CCS863001R1325	203139		0.735	1
	40	S803S-UCB40	2CCS863001R1405	203146		0.735	1
	50	S803S-UCB50	2CCS863001R1505	203153		0.735	1
	63	S803S-UCB63	2CCS863001R1635	203160		0.735	1
	80	S803S-UCB80	2CCS863001R1805	203177		0.735	1
	100	S803S-UCB100	2CCS863001R1825	203184		0.735	1
	125	S803S-UCB125	2CCS863001R1845	203191		0.735	1
	4	10	S804S-UCB10	2CCS864001R1105	203207		0.98
13		S804S-UCB13	2CCS864001R1135	203214		0.98	1
16		S804S-UCB16	2CCS864001R1165	203221		0.98	1
20		S804S-UCB20	2CCS864001R1205	203238		0.98	1
25		S804S-UCB25	2CCS864001R1255	203245		0.98	1
32		S804S-UCB32	2CCS864001R1325	203252		0.98	1
40		S804S-UCB40	2CCS864001R1405	203269		0.98	1
50		S804S-UCB50	2CCS864001R1505	203276		0.98	1
63		S804S-UCB63	2CCS864001R1635	203283		0.98	1
80		S804S-UCB80	2CCS864001R1805	203290		0.98	1
100		S804S-UCB100	2CCS864001R1825	203306		0.98	1
125		S804S-UCB125	2CCS864001R1845	203313		0.98	1

B

2

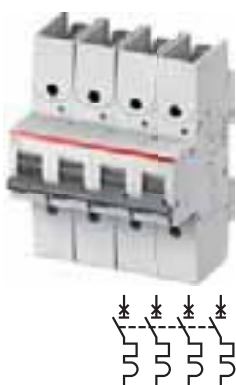

S800 S-UC B characteristic

Function: protection and control of the circuits against overloads and short-circuits when a high breaking capacity is required; protection for people and big length cables in TN and IT systems; very useful when selectivity is needed vs an MCCB or back-up vs other MCBs wired downstream; version dedicated to application in direct current circuits.

Applications: commercial and industrial.

Standard: IEC/EN 60947-2, VDE 0660 Part 101

I_{cu}=50 kA

Number of poles	Rated current	Order details		Bbn 7612271	Price 1 piece	Price group	Weight 1 piece	Pack unit
	In A	Type code	Order code	EAN			kg	pc.
1	10	S801S-UCB10-R	2CCS861002R1105	210359			0,245	1
	13	S801S-UCB13-R	2CCS861002R1135	210366			0,245	1
	16	S801S-UCB16-R	2CCS861002R1165	210373			0,245	1
	20	S801S-UCB20-R	2CCS861002R1205	210380			0,245	1
	25	S801S-UCB25-R	2CCS861002R1255	210397			0,245	1
	32	S801S-UCB32-R	2CCS861002R1325	210403			0,245	1
	40	S801S-UCB40-R	2CCS861002R1405	208424			0,245	1
	50	S801S-UCB50-R	2CCS861002R1505	208431			0,245	1
	63	S801S-UCB63-R	2CCS861002R1635	208448			0,245	1
	80	S801S-UCB80-R	2CCS861002R1805	208455			0,245	1
	100	S801S-UCB100-R	2CCS861002R1825	208462			0,245	1
125	S801S-UCB125-R	2CCS861002R1845	208479			0,245	1	
2	10	S802S-UCB10-R	2CCS862002R1105	210410			0,49	1
	13	S802S-UCB13-R	2CCS862002R1135	210427			0,49	1
	16	S802S-UCB16-R	2CCS862002R1165	210434			0,49	1
	20	S802S-UCB20-R	2CCS862002R1205	210441			0,49	1
	25	S802S-UCB25-R	2CCS862002R1255	210458			0,49	1
	32	S802S-UCB32-R	2CCS862002R1325	210465			0,49	1
	40	S802S-UCB40-R	2CCS862002R1405	208486			0,49	1
	50	S802S-UCB50-R	2CCS862002R1505	208493			0,49	1
	63	S802S-UCB63-R	2CCS862002R1635	208509			0,49	1
	80	S802S-UCB80-R	2CCS862002R1805	208516			0,49	1
	100	S802S-UCB100-R	2CCS862002R1825	208523			0,49	1
125	S802S-UCB125-R	2CCS862002R1845	208530			0,49	1	
3	10	S803S-UCB10-R	2CCS863002R1105	210472			0,735	1
	13	S803S-UCB13-R	2CCS863002R1135	210489			0,735	1
	16	S803S-UCB16-R	2CCS863002R1165	210496			0,735	1
	20	S803S-UCB20-R	2CCS863002R1205	210502			0,735	1
	25	S803S-UCB25-R	2CCS863002R1255	210519			0,735	1
	32	S803S-UCB32-R	2CCS863002R1325	210526			0,735	1
	40	S803S-UCB40-R	2CCS863002R1405	208547			0,735	1
	50	S803S-UCB50-R	2CCS863002R1505	208554			0,735	1
	63	S803S-UCB63-R	2CCS863002R1635	208561			0,735	1
	80	S803S-UCB80-R	2CCS863002R1805	208578			0,735	1
	100	S803S-UCB100-R	2CCS863002R1825	208585			0,735	1
125	S803S-UCB125-R	2CCS863002R1845	208592			0,735	1	
4	10	S804S-UCB10-R	2CCS864002R1105	210533			0,98	1
	13	S804S-UCB13-R	2CCS864002R1135	210540			0,98	1
	16	S804S-UCB16-R	2CCS864002R1165	210557			0,98	1
	20	S804S-UCB20-R	2CCS864002R1205	210564			0,98	1
	25	S804S-UCB25-R	2CCS864002R1255	210571			0,98	1
	32	S804S-UCB32-R	2CCS864002R1325	210588			0,98	1
	40	S804S-UCB40-R	2CCS864002R1405	208608			0,98	1
	50	S804S-UCB50-R	2CCS864002R1505	208615			0,98	1
	63	S804S-UCB63-R	2CCS864002R1635	208622			0,98	1
	80	S804S-UCB80-R	2CCS864002R1805	208639			0,98	1
	100	S804S-UCB100-R	2CCS864002R1825	208646			0,98	1
125	S804S-UCB125-R	2CCS864002R1845	208653			0,98	1	

K

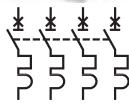
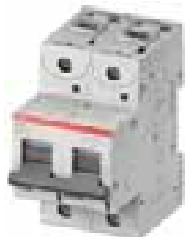

S800 S-UC K characteristic

Function: protection and control of the circuits like motors, transformer and auxiliary circuits, against overloads and short-circuits when a high breaking capacity is required; very useful when selectivity is needed vs an MCCB or back-up vs other MCBs wired downstream; version dedicated to application in direct current circuits.

Advantages: no nuisance tripping in the case of functional peak currents up to 10xIn, depending on the series; through its highly sensitive thermostatic bimetal trip, the K-type characteristic offers protection to damageable elements in the overcurrent range; it also provides the best protection to cables and lines.

Applications: commercial and industrial.

Standard: IEC/EN 60947-2

Icu=50 kA

Number of poles	Rated current In A	Order details Type code	Order code	Bbn 7612271 EAN	Price 1 piece	Price group	Weight 1 piece kg	Pack unit pc.
1	10	S801S-UCK10	2CCS861001R1427	203320			0.245	1
	13	S801S-UCK13	2CCS861001R1447	203337			0.245	1
	16	S801S-UCK16	2CCS861001R1467	203344			0.245	1
	20	S801S-UCK20	2CCS861001R1487	203351			0.245	1
	25	S801S-UCK25	2CCS861001R1517	203368			0.245	1
	32	S801S-UCK32	2CCS861001R1537	203375			0.245	1
	40	S801S-UCK40	2CCS861001R1557	203382			0.245	1
	50	S801S-UCK50	2CCS861001R1577	203399			0.245	1
	63	S801S-UCK63	2CCS861001R1597	203405			0.245	1
	80	S801S-UCK80	2CCS861001R1627	203412			0.245	1
	100	S801S-UCK100	2CCS861001R1637	203429			0.245	1
	125	S801S-UCK125	2CCS861001R1647	203436			0.245	1
2	10	S802S-UCK10	2CCS862001R1427	203443			0.49	1
	13	S802S-UCK13	2CCS862001R1447	203450			0.49	1
	16	S802S-UCK16	2CCS862001R1467	203467			0.49	1
	20	S802S-UCK20	2CCS862001R1487	203474			0.49	1
	25	S802S-UCK25	2CCS862001R1517	203481			0.49	1
	32	S802S-UCK32	2CCS862001R1537	203498			0.49	1
	40	S802S-UCK40	2CCS862001R1557	203504			0.49	1
	50	S802S-UCK50	2CCS862001R1577	203511			0.49	1
	63	S802S-UCK63	2CCS862001R1597	203528			0.49	1
	80	S802S-UCK80	2CCS862001R1627	203535			0.49	1
	100	S802S-UCK100	2CCS862001R1637	203542			0.49	1
	125	S802S-UCK125	2CCS862001R1647	203559			0.49	1
3	10	S803S-UCK10	2CCS863001R1427	203566			0.735	1
	13	S803S-UCK13	2CCS863001R1447	203573			0.735	1
	16	S803S-UCK16	2CCS863001R1467	203580			0.735	1
	20	S803S-UCK20	2CCS863001R1487	203597			0.735	1
	25	S803S-UCK25	2CCS863001R1517	203603			0.735	1
	32	S803S-UCK32	2CCS863001R1537	203610			0.735	1
	40	S803S-UCK40	2CCS863001R1557	203627			0.735	1
	50	S803S-UCK50	2CCS863001R1577	203634			0.735	1
	63	S803S-UCK63	2CCS863001R1597	203641			0.735	1
	80	S803S-UCK80	2CCS863001R1627	203658			0.735	1
	100	S803S-UCK100	2CCS863001R1637	203665			0.735	1
	125	S803S-UCK125	2CCS863001R1647	203672			0.735	1
4	10	S804S-UCK10	2CCS864001R1427	203689			0.98	1
	13	S804S-UCK13	2CCS864001R1447	203696			0.98	1
	16	S804S-UCK16	2CCS864001R1467	203702			0.98	1
	20	S804S-UCK20	2CCS864001R1487	203719			0.98	1
	25	S804S-UCK25	2CCS864001R1517	203726			0.98	1
	32	S804S-UCK32	2CCS864001R1537	203733			0.98	1
	40	S804S-UCK40	2CCS864001R1557	203740			0.98	1
	50	S804S-UCK50	2CCS864001R1577	203757			0.98	1
	63	S804S-UCK63	2CCS864001R1597	203764			0.98	1
	80	S804S-UCK80	2CCS864001R1627	203771			0.98	1
	100	S804S-UCK100	2CCS864001R1637	203788			0.98	1
	125	S804S-UCK125	2CCS864001R1647	203795			0.98	1

2

K

2

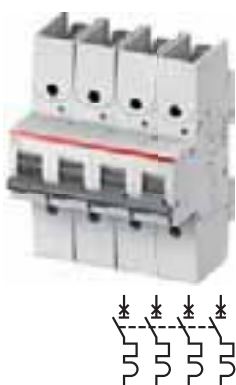
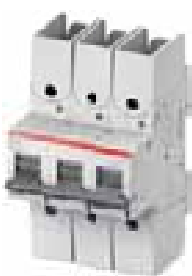

S800 S-UC K characteristic

Function: protection and control of the circuits like motors, transformer and auxiliary circuits, against overloads and short-circuits when a high breaking capacity is required; very useful when selectivity is needed vs an MCCB or back-up vs other MCBs wired downstream; version dedicated to application in direct current circuits.

Advantages: no nuisance tripping in the case of functional peak currents up to 10xI_n, depending on the series; through its highly sensitive thermostatic bimetal trip, the K-type characteristic offers protection to damageable elements in the overcurrent range; it also provides the best protection to cables and lines.

Applications: commercial and industrial.

Standard: IEC/EN 60947-2, VDE 0660 Part 101

I_{cu}=50 kA

Number of poles	Rated current	Order details		Bbn 7612271	Price 1 piece	Price group	Weight 1 piece	Pack unit
	In A	Type code	Order code	EAN			kg	pc.
1	10	S801S-UCK10-R	2CCS861002R1427	210595			0,245	1
	13	S801S-UCK13-R	2CCS861002R1447	210601			0,245	1
	16	S801S-UCK16-R	2CCS861002R1467	210618			0,245	1
	20	S801S-UCK20-R	2CCS861002R1487	210625			0,245	1
	25	S801S-UCK25-R	2CCS861002R1517	210632			0,245	1
	32	S801S-UCK32-R	2CCS861002R1537	210649			0,245	1
	40	S801S-UCK40-R	2CCS861002R1557	208660			0,245	1
	50	S801S-UCK50-R	2CCS861002R1577	208677			0,245	1
	63	S801S-UCK63-R	2CCS861002R1597	208684			0,245	1
	80	S801S-UCK80-R	2CCS861002R1627	208691			0,245	1
	100	S801S-UCK100-R	2CCS861002R1637	208707			0,245	1
	125	S801S-UCK125-R	2CCS861002R1647	208714			0,245	1
2	10	S802S-UCK10-R	2CCS862002R1427	210656			0,490	1
	13	S802S-UCK13-R	2CCS862002R1447	210663			0,490	1
	16	S802S-UCK16-R	2CCS862002R1467	210670			0,490	1
	20	S802S-UCK20-R	2CCS862002R1487	210687			0,490	1
	25	S802S-UCK25-R	2CCS862002R1517	210694			0,490	1
	32	S802S-UCK32-R	2CCS862002R1537	210700			0,490	1
	40	S802S-UCK40-R	2CCS862002R1557	208721			0,490	1
	50	S802S-UCK50-R	2CCS862002R1577	208738			0,490	1
	63	S802S-UCK63-R	2CCS862002R1597	208745			0,490	1
	80	S802S-UCK80-R	2CCS862002R1627	208752			0,490	1
	100	S802S-UCK100-R	2CCS862002R1637	208769			0,490	1
	125	S802S-UCK125-R	2CCS862002R1647	208776			0,490	1
3	10	S803S-UCK10-R	2CCS863002R1427	210717			0,735	1
	13	S803S-UCK13-R	2CCS863002R1447	210724			0,735	1
	16	S803S-UCK16-R	2CCS863002R1467	210731			0,735	1
	20	S803S-UCK20-R	2CCS863002R1487	210748			0,735	1
	25	S803S-UCK25-R	2CCS863002R1517	210755			0,735	1
	32	S803S-UCK32-R	2CCS863002R1537	210762			0,735	1
	40	S803S-UCK40-R	2CCS863002R1557	208783			0,735	1
	50	S803S-UCK50-R	2CCS863002R1577	208790			0,735	1
	63	S803S-UCK63-R	2CCS863002R1597	208806			0,735	1
	80	S803S-UCK80-R	2CCS863002R1627	208813			0,735	1
	100	S803S-UCK100-R	2CCS863002R1637	208820			0,735	1
	125	S803S-UCK125-R	2CCS863002R1647	208837			0,735	1
4	10	S804S-UCK10-R	2CCS864002R1427	210779			0,98	1
	13	S804S-UCK13-R	2CCS864002R1447	210786			0,98	1
	16	S804S-UCK16-R	2CCS864002R1467	210793			0,98	1
	20	S804S-UCK20-R	2CCS864002R1487	210809			0,98	1
	25	S804S-UCK25-R	2CCS864002R1517	210816			0,98	1
	32	S804S-UCK32-R	2CCS864002R1537	210823			0,98	1
	40	S804S-UCK40-R	2CCS864002R1557	208844			0,98	1
	50	S804S-UCK50-R	2CCS864002R1577	208851			0,98	1
	63	S804S-UCK63-R	2CCS864002R1597	208868			0,98	1
	80	S804S-UCK80-R	2CCS864002R1627	208875			0,98	1
	100	S804S-UCK100-R	2CCS864002R1637	208882			0,98	1
	125	S804S-UCK125-R	2CCS864002R1647	208899			0,98	1

B



S800 N-B characteristic

Function: protection and control of the circuits against overloads and short-circuits when a high breaking capacity is required; protection for people and big length cables in TN and IT systems; very useful when selectivity is needed vs an MCCB or back-up vs other MCBs wired downstream.

Applications: commercial and industrial.

Standard: IEC/EN 60898, IEC/EN 60947-2

Icn=25 kA

Icu=36 kA

Number of poles	Rated current In A	Order details Type code	Order code	Bbn 7612271 EAN	Price 1 piece	Price group	Weight 1 piece kg	Pack unit pc.
1	10	S801N-B10	2CCS891001R0105	203801			0.24	1
	13	S801N-B13	2CCS891001R0135	203818			0.24	1
	16	S801N-B16	2CCS891001R0165	203825			0.24	1
	20	S801N-B20	2CCS891001R0205	203832			0.24	1
	25	S801N-B25	2CCS891001R0255	203849			0.24	1
	32	S801N-B32	2CCS891001R0325	203856			0.24	1
	40	S801N-B40	2CCS891001R0405	203863			0.24	1
	50	S801N-B50	2CCS891001R0505	203870			0.24	1
	63	S801N-B63	2CCS891001R0635	203887			0.24	1
	80	S801N-B80	2CCS891001R0805	203894			0.24	1
	100	S801N-B100	2CCS891001R0825	203900			0.24	1
	125	S801N-B125	2CCS891001R0845	203917			0.24	1
2	10	S802N-B10	2CCS892001R0105	203924			0.48	1
	13	S802N-B13	2CCS892001R0135	203931			0.48	1
	16	S802N-B16	2CCS892001R0165	203948			0.48	1
	20	S802N-B20	2CCS892001R0205	203955			0.48	1
	25	S802N-B25	2CCS892001R0255	203962			0.48	1
	32	S802N-B32	2CCS892001R0325	203979			0.48	1
	40	S802N-B40	2CCS892001R0405	203986			0.48	1
	50	S802N-B50	2CCS892001R0505	203993			0.48	1
	63	S802N-B63	2CCS892001R0635	204006			0.48	1
	80	S802N-B80	2CCS892001R0805	204013			0.48	1
	100	S802N-B100	2CCS892001R0825	204020			0.48	1
	125	S802N-B125	2CCS892001R0845	204037			0.48	1
3	10	S803N-B10	2CCS893001R0105	204044			0.72	1
	13	S803N-B13	2CCS893001R0135	204051			0.72	1
	16	S803N-B16	2CCS893001R0165	204068			0.72	1
	20	S803N-B20	2CCS893001R0205	204075			0.72	1
	25	S803N-B25	2CCS893001R0255	204082			0.72	1
	32	S803N-B32	2CCS893001R0325	204099			0.72	1
	40	S803N-B40	2CCS893001R0405	204105			0.72	1
	50	S803N-B50	2CCS893001R0505	204112			0.72	1
	63	S803N-B63	2CCS893001R0635	204129			0.72	1
	80	S803N-B80	2CCS893001R0805	204136			0.72	1
	100	S803N-B100	2CCS893001R0825	204143			0.72	1
	125	S803N-B125	2CCS893001R0845	204150			0.72	1
4	10	S804N-B10	2CCS894001R0105	204167			0.96	1
	13	S804N-B13	2CCS894001R0135	204174			0.96	1
	16	S804N-B16	2CCS894001R0165	204181			0.96	1
	20	S804N-B20	2CCS894001R0205	204198			0.96	1
	25	S804N-B25	2CCS894001R0255	204204			0.96	1
	32	S804N-B32	2CCS894001R0325	204211			0.96	1
	40	S804N-B40	2CCS894001R0405	204228			0.96	1
	50	S804N-B50	2CCS894001R0505	204235			0.96	1
	63	S804N-B63	2CCS894001R0635	204242			0.96	1
	80	S804N-B80	2CCS894001R0805	204259			0.96	1
	100	S804N-B100	2CCS894001R0825	204266			0.96	1
	125	S804N-B125	2CCS894001R0845	204273			0.96	1

2

C

2

S800 N-C characteristic

Function: protection and control of the circuits against overloads and short-circuits when a high breaking capacity is required; protection for resistive and inductive loads with low inrush current; very useful when selectivity is needed vs an MCCB or back-up vs other MCBs wired downstream.

Applications: commercial and industrial.

Standard: IEC/EN 60898, IEC/EN 60947-2

Icn=25 kA

Icu=36 kA

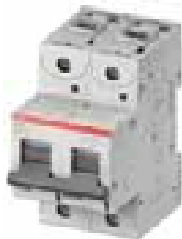

Number of poles	Rated current	Order details	Bbn	Price 1 piece	Price group	Weight 1 piece	Pack unit
In A	Type code	Order code	EAN			kg	pc.
1	10	S801N-C10	2CCS891001R0104	204280		0.24	1
	13	S801N-C13	2CCS891001R0134	204297		0.24	1
	16	S801N-C16	2CCS891001R0164	204303		0.24	1
	20	S801N-C20	2CCS891001R0204	204310		0.24	1
	25	S801N-C25	2CCS891001R0254	204327		0.24	1
	32	S801N-C32	2CCS891001R0324	204334		0.24	1
	40	S801N-C40	2CCS891001R0404	204341		0.24	1
	50	S801N-C50	2CCS891001R0504	204358		0.24	1
	63	S801N-C63	2CCS891001R0634	204365		0.24	1
	80	S801N-C80	2CCS891001R0804	204372		0.24	1
	100	S801N-C100	2CCS891001R0824	204389		0.24	1
	125	S801N-C125	2CCS891001R0844	204396		0.24	1
2	10	S802N-C10	2CCS892001R0104	204402		0.48	1
	13	S802N-C13	2CCS892001R0134	204419		0.48	1
	16	S802N-C16	2CCS892001R0164	204426		0.48	1
	20	S802N-C20	2CCS892001R0204	204433		0.48	1
	25	S802N-C25	2CCS892001R0254	204440		0.48	1
	32	S802N-C32	2CCS892001R0324	204457		0.48	1
	40	S802N-C40	2CCS892001R0404	204464		0.48	1
	50	S802N-C50	2CCS892001R0504	204471		0.48	1
	63	S802N-C63	2CCS892001R0634	204488		0.48	1
	80	S802N-C80	2CCS892001R0804	204495		0.48	1
	100	S802N-C100	2CCS892001R0824	204501		0.48	1
	125	S802N-C125	2CCS892001R0844	204518		0.48	1
3	10	S803N-C10	2CCS893001R0104	204525		0.72	1
	13	S803N-C13	2CCS893001R0134	204532		0.72	1
	16	S803N-C16	2CCS893001R0164	204549		0.72	1
	20	S803N-C20	2CCS893001R0204	204556		0.72	1
	25	S803N-C25	2CCS893001R0254	204563		0.72	1
	32	S803N-C32	2CCS893001R0324	204570		0.72	1
	40	S803N-C40	2CCS893001R0404	204587		0.72	1
	50	S803N-C50	2CCS893001R0504	204594		0.72	1
	63	S803N-C63	2CCS893001R0634	204600		0.72	1
	80	S803N-C80	2CCS893001R0804	204617		0.72	1
	100	S803N-C100	2CCS893001R0824	204624		0.72	1
	125	S803N-C125	2CCS893001R0844	204631		0.72	1
4	10	S804N-C10	2CCS894001R0104	204648		0.96	1
	13	S804N-C13	2CCS894001R0134	204655		0.96	1
	16	S804N-C16	2CCS894001R0164	204662		0.96	1
	20	S804N-C20	2CCS894001R0204	204679		0.96	1
	25	S804N-C25	2CCS894001R0254	204686		0.96	1
	32	S804N-C32	2CCS894001R0324	204693		0.96	1
	40	S804N-C40	2CCS894001R0404	204709		0.96	1
	50	S804N-C50	2CCS894001R0504	204716		0.96	1
	63	S804N-C63	2CCS894001R0634	204723		0.96	1
	80	S804N-C80	2CCS894001R0804	204730		0.96	1
	100	S804N-C100	2CCS894001R0824	204747		0.96	1
	125	S804N-C125	2CCS894001R0844	204754		0.96	1

D

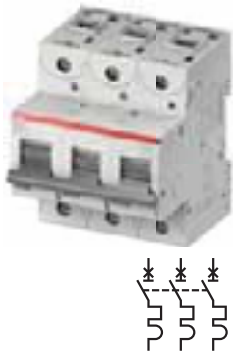
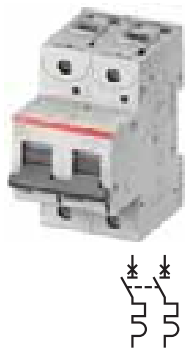

S800 N-D characteristic

Function: protection and control of the circuits against overloads and short-circuits when a high breaking capacity is required; protection for circuits which supply loads with high inrush current at the circuit closing (motors, LV / LV transformers, breakdown lamps); very useful when selectivity is needed vs an MCCB or back-up vs other MCBs wired downstream.

Applications: commercial and industrial.

Standard: IEC/EN 60898, IEC/EN 60947-2

Icn=25 kA

Icu=36 kA

Number of poles	Rated current	Order details	Bbn 7612271	Price 1 piece	Price group	Weight 1 piece	Pack unit
	In A	Type code	Order code	EAN		kg	pc.
1	10	S801N-D10	2CCS891001R0101	204761		0.245	1
	13	S801N-D13	2CCS891001R0131	204778		0.245	1
	16	S801N-D16	2CCS891001R0161	204785		0.245	1
	20	S801N-D20	2CCS891001R0201	204792		0.245	1
	25	S801N-D25	2CCS891001R0251	204808		0.245	1
	32	S801N-D32	2CCS891001R0321	204815		0.245	1
	40	S801N-D40	2CCS891001R0401	204822		0.245	1
	50	S801N-D50	2CCS891001R0501	204839		0.245	1
	63	S801N-D63	2CCS891001R0631	204846		0.245	1
	80	S801N-D80	2CCS891001R0801	204853		0.245	1
	100	S801N-D100	2CCS891001R0821	204860		0.245	1
	125	S801N-D125	2CCS891001R0841	204877		0.245	1
	2	10	S802N-D10	2CCS892001R0101	204884		0.49
13		S802N-D13	2CCS892001R0131	204891		0.49	1
16		S802N-D16	2CCS892001R0161	204907		0.49	1
20		S802N-D20	2CCS892001R0201	204914		0.49	1
25		S802N-D25	2CCS892001R0251	204921		0.49	1
32		S802N-D32	2CCS892001R0321	204938		0.49	1
40		S802N-D40	2CCS892001R0401	204945		0.49	1
50		S802N-D50	2CCS892001R0501	204952		0.49	1
63		S802N-D63	2CCS892001R0631	204969		0.49	1
80		S802N-D80	2CCS892001R0801	204976		0.49	1
100		S802N-D100	2CCS892001R0821	204983		0.49	1
125		S802N-D125	2CCS892001R0841	204990		0.49	1
3		10	S803N-D10	2CCS893001R0101	205003		0.735
	13	S803N-D13	2CCS893001R0131	205010		0.735	1
	16	S803N-D16	2CCS893001R0161	205027		0.735	1
	20	S803N-D20	2CCS893001R0201	205034		0.735	1
	25	S803N-D25	2CCS893001R0251	205041		0.735	1
	32	S803N-D32	2CCS893001R0321	205058		0.735	1
	40	S803N-D40	2CCS893001R0401	205065		0.735	1
	50	S803N-D50	2CCS893001R0501	205072		0.735	1
	63	S803N-D63	2CCS893001R0631	205089		0.735	1
	80	S803N-D80	2CCS893001R0801	205096		0.735	1
	100	S803N-D100	2CCS893001R0821	205102		0.735	1
	125	S803N-D125	2CCS893001R0841	205119		0.735	1
	4	10	S804N-D10	2CCS894001R0101	205126		0.98
13		S804N-D13	2CCS894001R0131	205133		0.98	1
16		S804N-D16	2CCS894001R0161	205140		0.98	1
20		S804N-D20	2CCS894001R0201	205157		0.98	1
25		S804N-D25	2CCS894001R0251	205164		0.98	1
32		S804N-D32	2CCS894001R0321	205171		0.98	1
40		S804N-D40	2CCS894001R0401	205188		0.98	1
50		S804N-D50	2CCS894001R0501	205195		0.98	1
63		S804N-D63	2CCS894001R0631	205201		0.98	1
80		S804N-D80	2CCS894001R0801	205218		0.98	1
100		S804N-D100	2CCS894001R0821	205225		0.98	1
125		S804N-D125	2CCS894001R0841	205232		0.98	1



2CSC400266F0201



2CSC400256F0201



2CSC400162F0201



2CSC400170F0201



Index

F 200, DDA 200, FS 201 and DS 200 System pro <i>M</i> compact RCDs	3/2
DS 9.. and DS 271 RCBOs 1P+N	3/38
DDA 60, 70, 90 for S 290 MCBs, DDA 800 RCD-blocks and DS800	3/56

RCDs assure a protection to people and installations against fault current to earth. They are divided into three families:

- **RCCBs**, which are sensitive only to earth fault current (therefore they have to be connected in series with a MCB or a fuse to protect them against overcurrents and short-circuits)
- **RCD-blocks**, which are devices to be assembled on a MCB with lower or equal rated current to provide protection against both earth-fault currents and overload or short-circuits
- **RCBOs**, which combines in a single device protection against both earth-fault currents and overloads or short-circuits.

New RCDs System pro *M* compact range presents a wide offer for all the three families, respectively **F 200**, **DDA 200** and **DS 200** series.

A large offer for standard instantaneous and selective AC and A types is completed with some configurations for special applications, like AP-R type against perturbations or AE type for emergency stop.

All sizes up to 63 A with all the sensitivity thresholds up to 1 A are offered in all the possible pole configurations.

ABB RCDs obtained a lot of marks and approvals and offer the same "plus" advantages of the other System pro *M* compact devices.



2CSC400255F0201



2CSC400256F0201



2CSC400257F0201



2CSC400162F0201



2CSC400181F0201



2CSC400180F0201



2CSC400253F0201



2CSC400252F0201



Residual current devices F 200, DDA 200, FS 201 and DS 200 series



Index

Technical features of RCCBs F 200 series	3/4
Selection tables of RCCBs F 200 series	
F 200 AC	3/6
F 200 A	3/7
F 200 AC IEC standard	3/8
F 200 left neutral	3/9
F 200 AP-R AC	3/10
F 200 AP-R A	3/11
F 200 AC S	3/12
F 200 A S	3/13
F 200 A 400 Hz	3/14
F 200 B	3/15
Technical features of RCD-blocks DDA 200 series	3/16
Selection tables of RCD-blocks DDA 200 series	
DDA 200 AC	3/18
DDA 200 A	3/19
DDA 200 AE	3/20
DDA 200 B	3/21
DDA 200 AP-R	3/22
DDA 200 AC S	3/24
DDA 200 A S	3/25
Technical features of RCBOs FS 201 and DS 200 series	3/26
Selection tables of RCBOs FS 201 series and DS 200 series	
FS 201	3/28
DS 200 AC B	3/30
DS 200 AC C	3/31
DS 200 A B	3/32
DS 200 A C	3/33
DS 200 M AC B	3/34
DS 200 M AC C	3/35
DS 200 M A B	3/36
DS 200 M A C	3/37

TECHNICAL FEATURES			
	Standards		
Electrical features	Type (wave form of the earth leakage sensed)		
	Poles		
	Rated current I _n		A
	Rated sensitivity I _{Δn}		A
	Rated voltage U _e	IEC	V
		UL/CSA	V
	Insulation voltage U _i		V
	Max. operating voltage of circuit test	IEC	V
		UL/CSA	V
	Min. operating voltage of circuit test		V
	Rated frequency		Hz
	Rated conditional short-circuit current I _{nc} =I _{Δc}	SCPD - fuse gL 100 A	kA
	Rated residual breaking capacity I _{Δm} =I _m		kA
	Rated impulse withstand voltage (1.2/50) U _{imp}		kV
Dielectric test voltage at ind. freq. for 1 min.		kV	
Overvoltage category			
Surge current resistance (wave 8/20)		A	
Mechanical features	Toggle		
	Contact position indicator (CPI)		
	Electrical life		
	Mechanical life		
	Protection degree	housing terminals	
	Tropicalization acc. to IEC/EN 60068-2	humid heat	°C/RH
		constant climatic conditions	°C/RH
		variable climatic conditions	°C/RH
Ambient temperature (with daily average ≤ +35 °C)	IEC	°C	
	UL/CSA	°C	
Storage temperature		°C	
Installation	Terminal type		
	Terminal size top/bottom for cable	IEC	mm ²
		UL/CSA	AWG
	Terminal size top/bottom for busbar	IEC	mm ²
		UL/CSA	AWG
	Tightening torque	IEC	N*m
		UL/CSA	in-lbs.
Tool			
Mounting			
Connection			
Withdrawal from busbar			
Dimensions and weight	Dimensions (H x D x W)	2P	mm
		4P	mm
	Weight	2P	g
		4P	g
Combination with auxiliary elements	Combinable with:	auxiliary contact	
		signal contact/auxiliary switch	
		shunt trip	
		undervoltage release	

① Ground-fault sensing and relaying equipment-component (up to 63 A)

② prior to connection of aluminium conductors (≥ 4 mm²) ensure that their contact points are cleaned, brushed and coated with grease

System pro M compact® Technical features

RCCBs F 200 series

F 200



3

F200 AC	F200 A	F200 AC AP-R	F200 A AP-R	F200 AC S	F200 A S	F200 A 400 Hz	F200 B
IEC/EN 61008, UL 1053 ①						IEC/EN 61008	IEC/EN 61008, IEC 62423
AC	A	AC	A	AC	A	A	B
2P, 4P (for 125 A only 4P)		2P, 4P (for 125 A only 4P)		2P, 4P (for 125 A only 4P)		4P	4P
16, 25, 40, 63, 80, 100, 125	25, 40, 63	25, 40, 63	25, 40, 63, 80, 100, 125	40, 63	40, 63, 80, 100, 125	25, 40	40, 63
0.01-0.03-0.1-0.3-0.5		0.03		0.1-0.3-0.5-1		0.03	0.03-0.3
230/400 - 240/415 480Y/277 (up to 63 A)							-
500							
254 (440 for 125 A); 440 for F 200 left neutral 277 (up to 63 A); 480 for F 200 left neutral 110 (185 for 125 A); 195 for F 200 left neutral 50...60						254	440
						110	185
						50...400	50...60
10 (for 125 A fuse is gL 125 A) 1 (1.25 for 125 A) 6							5
2.5							
III, disconnector abilities							
250	3000		5000			250	3000 (5000 for selective type)
blue sealable in ON-OFF position							
yes							no
10000 (2000 for 125 A) 20000 (5000 for 125 A)						10000	2000
						20000	5000
IP4X IP2X							
28 cycles with 55/95...100 23/83 - 40/93 - 55/20 25/95 - 40/95							
-25...+55 (-25...+40 for 125 A) -35...+70 (up to 63 A)						-25...+55	-25...+40
-40...+70							-
failsafe bi-directional cylinder-lift terminal at top and bottom (shock protected) (cage for In > 63 A) ②							
25/25 (35/35 single slot terminal for In > 63 A) 18-4 (up to 63 A)						25/25	50/50
10/10 (not for In = 80-100 A) 18-8 (up to 63 A)						10/10	-
2.8 (4.8 for In > 63 A; 3 for In = 125 A) 25 (up to 63 A)						2.8	3
Nr. 2 Pozidriv							
on DIN rail EN 60715 (35 mm) by means of fast clip device from top and bottom							
it is possible without using any tools only from the bottom (not for 125 A)							
85 x 69 x 35 85 x 69 x 70 (85 x 69.5 x 72 for 125 A)						85 x 69 x 70	85 x 69.5 x 72
200							
350 (380 for In = 80 and 100 A and 460 for In = 125A)						350	500
yes (no for 125 A)						yes	no
yes						yes	yes
yes (no for 125 A)						yes	no
yes (no for 125 A)						yes	no

AC

F 200 AC type

Function: protection against the effects of sinusoidal alternating earth fault currents; protection against indirect contacts and additional protection against direct (with $I_{\Delta n}=30$ mA) contacts; command and isolation of resistive and inductive circuits.

Application: residential, commercial, industrial.

Standard: IEC/EN 61008

Marking: according to EN 61008

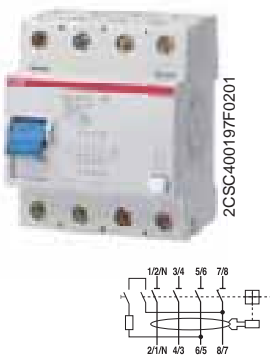
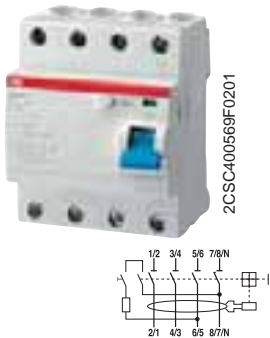

Number of poles	Rated residual current	Rated current	Order details		Bbn 8012542	Price 1 piece	Price group	Weight 1 piece	Pack unit
			$I_{\Delta n}$ mA	In A					
2	10	16	F202 AC-16/0.01	2CSF202001R0160	779902			0.225	1/6
		25	F202 AC-25/0.03	2CSF202001R1250	780007			0.225	1/6
		40	F202 AC-40/0.03	2CSF202001R1400	780106			0.225	1/6
		63	F202 AC-63/0.03	2CSF202001R1630	780205			0.225	1/6
		80	F202 AC-80/0.03	2CSF202001R1800	914204			0.225	1/6
	30	100	F202 AC-100/0.03	2CSF202001R1900	914303			0.225	1/6
		25	F202 AC-25/0.1	2CSF202001R2250	780304			0.225	1/6
		40	F202 AC-40/0.1	2CSF202001R2400	780403			0.225	1/6
		63	F202 AC-63/0.1	2CSF202001R2630	780502			0.225	1/6
		80	F202 AC-80/0.1	2CSF202001R2800	914402			0.225	1/6
	100	100	F202 AC-100/0.1	2CSF202001R2900	914501			0.225	1/6
		25	F202 AC-25/0.3	2CSF202001R3250	780601			0.225	1/6
		40	F202 AC-40/0.3	2CSF202001R3400	780700			0.225	1/6
		63	F202 AC-63/0.3	2CSF202001R3630	780809			0.225	1/6
		80	F202 AC-80/0.3	2CSF202001R3800	914600			0.225	1/6
300	100	F202 AC-100/0.3	2CSF202001R3900	914709			0.225	1/6	
	25	F202 AC-25/0.5	2CSF202001R4250	780908			0.225	1/6	
	40	F202 AC-40/0.5	2CSF202001R4400	781004			0.225	1/6	
	63	F202 AC-63/0.5	2CSF202001R4630	781103			0.225	1/6	
	80	F202 AC-80/0.5	2CSF202001R4800	914808			0.225	1/6	
4	30	25	F204 AC-25/0.03	2CSF204001R1250	781202			0.375	1/3
		40	F204 AC-40/0.03	2CSF204001R1400	781301			0.375	1/3
		63	F204 AC-63/0.03	2CSF204001R1630	781400			0.375	1/3
		80	F204 AC-80/0.03	2CSF204001R1800	916604			0.405	1/3
		100	F204 AC-100/0.03	2CSF204001R1900	916703			0.405	1/3
	100	125	F204 AC-125/0.03	2CSF204001R1950	941507			0.500	1
		25	F204 AC-25/0.1	2CSF204001R2250	781509			0.375	1/3
		40	F204 AC-40/0.1	2CSF204001R2400	781608			0.375	1/3
		63	F204 AC-63/0.1	2CSF204001R2630	781707			0.375	1/3
		80	F204 AC-80/0.1	2CSF204001R2800	916802			0.405	1/3
	300	100	F204 AC-100/0.1	2CSF204001R2900	916901			0.405	1/3
		125	F204 AC-125/0.1	2CSF204001R2950	941606			0.500	1
		25	F204 AC-25/0.3	2CSF204001R3250	781806			0.375	1/3
		40	F204 AC-40/0.3	2CSF204001R3400	781905			0.375	1/3
		63	F204 AC-63/0.3	2CSF204001R3630	782001			0.375	1/3
500	80	F204 AC-80/0.3	2CSF204001R3800	917007			0.405	1/3	
	100	F204 AC-100/0.3	2CSF204001R3900	917106			0.405	1/3	
	125	F204 AC-125/0.3	2CSF204001R3950	941705			0.500	1	
	25	F204 AC-25/0.5	2CSF204001R4250	782100			0.375	1/3	
	40	F204 AC-40/0.5	2CSF204001R4400	782209			0.375	1/3	
	63	F204 AC-63/0.5	2CSF204001R4630	782308			0.375	1/3	
	80	F204 AC-80/0.5	2CSF204001R4800	917205			0.405	1/3	
	100	F204 AC-100/0.5	2CSF204001R4900	917304			0.405	1/3	
	125	F204 AC-125/0.5	2CSF204001R4950	941804			0.500	1	

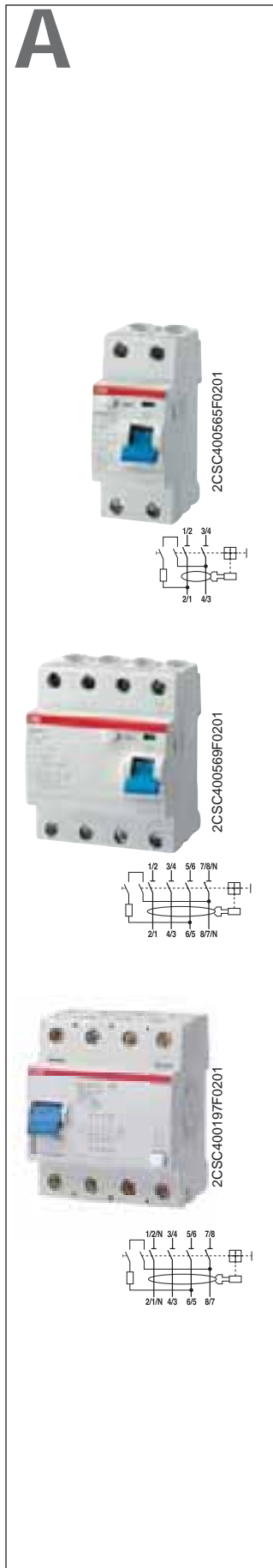

F 200 A type

Function: protection against the effects of sinusoidal alternating and direct pulsating earth fault currents; protection against indirect contacts and additional protection against direct (with $I\Delta n=30$ mA) contacts; command and isolation of resistive and inductive circuits.

Application: residential, commercial, industrial.

Standard: IEC/EN 61008

Marking: according to EN 61008

Number of poles	Rated residual current	Rated current	Order details		Bbn 8012542	Price 1 piece	Price group	Weight 1 piece	Pack unit
	$I\Delta n$ mA	In A	Type code	Order code	EAN			kg	pc.
2	10	16	F202 A-16/0.01	2CSF202101R0160	782407			0.225	1/6
		25	F202 A-25/0.03	2CSF202101R1250	782506		0.225	1/6	
		40	F202 A-40/0.03	2CSF202101R1400	782605		0.225	1/6	
		63	F202 A-63/0.03	2CSF202101R1630	782704		0.225	1/6	
		80	F202 A-80/0.03	2CSF202101R1800	915201		0.225	1/6	
	100	100	F202 A-100/0.03	2CSF202101R1900	915300		0.225	1/6	
		25	F202 A-25/0.1	2CSF202101R2250	786900		0.225	1/6	
		40	F202 A-40/0.1	2CSF202101R2400	787006		0.225	1/6	
		63	F202 A-63/0.1	2CSF202101R2630	787105		0.225	1/6	
		80	F202 A-80/0.1	2CSF202101R2800	915409		0.225	1/6	
	300	100	F202 A-100/0.1	2CSF202101R2900	915508		0.225	1/6	
		25	F202 A-25/0.3	2CSF202101R3250	782803		0.225	1/6	
		40	F202 A-40/0.3	2CSF202101R3400	782902		0.225	1/6	
		63	F202 A-63/0.3	2CSF202101R3630	783008		0.225	1/6	
		80	F202 A-80/0.3	2CSF202101R3800	915607		0.225	1/6	
500	100	F202 A-100/0.3	2CSF202101R3900	915706		0.225	1/6		
	25	F202 A-25/0.5	2CSF202101R4250	783107		0.225	1/6		
	40	F202 A-40/0.5	2CSF202101R4400	783206		0.225	1/6		
	63	F202 A-63/0.5	2CSF202101R4630	783305		0.225	1/6		
	80	F202 A-80/0.5	2CSF202101R4800	915805		0.225	1/6		
4	30	100	F202 A-100/0.5	2CSF202101R4900	915904		0.225	1/6	
		25	F204 A-25/0.03	2CSF204101R1250	783404		0.375	1/3	
		40	F204 A-40/0.03	2CSF204101R1400	783503		0.375	1/3	
		63	F204 A-63/0.03	2CSF204101R1630	783602		0.375	1/3	
		80	F204 A-80/0.03	2CSF204101R1800	917809		0.405	1/3	
	100	100	F204 A-100/0.03	2CSF204101R1900	917908		0.405	1/3	
		125	F204 A-125/0.03	2CSF204101R1950	941903		0.500	1	
		25	F204 A-25/0.1	2CSF204101R2250	787204		0.375	1/3	
		40	F204 A-40/0.1	2CSF204101R2400	787303		0.375	1/3	
		63	F204 A-63/0.1	2CSF204101R2630	787402		0.375	1/3	
	300	80	F204 A-80/0.1	2CSF204101R2800	918004		0.405	1/3	
		100	F204 A-100/0.1	2CSF204101R2900	918103		0.405	1/3	
		125	F204 A-125/0.1	2CSF204101R2950	942009		0.500	1	
		25	F204 A-25/0.3	2CSF204101R3250	783701		0.375	1/3	
		40	F204 A-40/0.3	2CSF204101R3400	783800		0.375	1/3	
500	63	F204 A-63/0.3	2CSF204101R3630	783909		0.375	1/3		
	80	F204 A-80/0.3	2CSF204101R3800	918202		0.405	1/3		
	100	F204 A-100/0.3	2CSF204101R3900	918301		0.405	1/3		
	125	F204 A-125/0.3	2CSF204101R3950	942108		0.500	1		
	25	F204 A-25/0.5	2CSF204101R4250	784005		0.375	1/3		
100	40	F204 A-40/0.5	2CSF204101R4400	784104		0.375	1/3		
	63	F204 A-63/0.5	2CSF204101R4630	784203		0.375	1/3		
	80	F204 A-80/0.5	2CSF204101R4800	918400		0.405	1/3		
	100	F204 A-100/0.5	2CSF204101R4900	918509		0.405	1/3		
	125	F204 A-125/0.5	2CSF204101R4950	942207		0.500	1		

AC

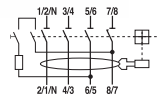
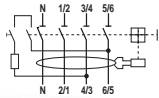

F 200 AC type with neutral pole on the left

Function: protection against the effects of sinusoidal alternating earth fault currents; protection against indirect contacts and additional protection against direct (with $I_{\Delta n}=30$ mA) contacts; command and isolation of resistive and inductive circuits. Product helpful where for installation habits, for wiring with busbars or cables, for special needs neutral on the left is needed.

Application: residential, commercial, industrial.

Standard: IEC/EN 61008

Marking: according to EN 61008

Number of poles	Rated residual current	Rated current	Order details		Bbn 8012542	Price 1 piece	Price group	Weight 1 piece	Pack unit
			$I_{\Delta n}$ mA	In A					
4	30	25	F204 AC-25/0.03	2CSF204023R1250	815907			0.375	1/3
		40	F204 AC-40/0.03	2CSF204023R1400	816003			0.375	1/3
		63	F204 AC-63/0.03	2CSF204023R1630	816102			0.375	1/3
		80	F204 AC-80/0.03	2CSF204023R1800	917403			0.405	1/3
		100	F204 AC-100/0.03	2CSF204023R1900	917502			0.405	1/3
		125	F204 AC-125/0.03	2CSF204023R1950	975106			0.500	1
100	25	25	F204 AC-25/0.1	2CSF204023R2250	816201			0.375	1/3
		40	F204 AC-40/0.1	2CSF204023R2400	816300			0.375	1/3
		63	F204 AC-63/0.1	2CSF204023R2630	816409			0.375	1/3
300	25	25	F204 AC-25/0.3	2CSF204023R3250	816508			0.375	1/3
		40	F204 AC-40/0.3	2CSF204023R3400	816607			0.375	1/3
		63	F204 AC-63/0.3	2CSF204023R3630	816706			0.375	1/3
		80	F204 AC-80/0.3	2CSF204023R3800	917601			0.405	1/3
		100	F204 AC-100/0.3	2CSF204023R3900	917700			0.405	1/3
		125	F204 AC-125/0.3	2CSF204023R3950	975304			0.500	1
500	25	25	F204 AC-25/0.5	2CSF204023R4250	816805			0.375	1/3
		40	F204 AC-40/0.5	2CSF204023R4400	816904			0.375	1/3
		63	F204 AC-63/0.5	2CSF204023R4630	817000			0.375	1/3

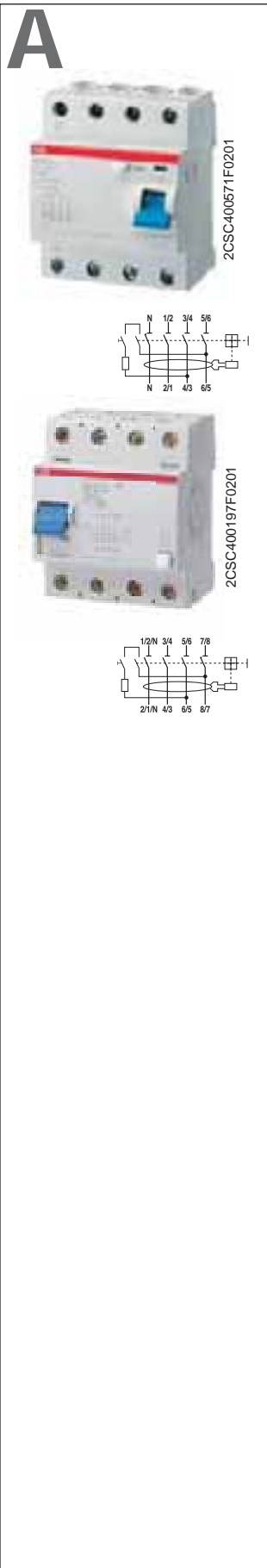

F 200 A type with neutral pole on the left

Function: protection against the effects of sinusoidal alternating and direct pulsating earth fault currents; protection against indirect contacts and additional protection against direct (with $I_{\Delta n}=30$ mA) contacts; command and isolation of resistive and inductive circuits. Product helpful where for installation habits, for wiring with busbars or cables, for special needs neutral on the left is needed.

Application: residential, commercial, industrial.

Standard: IEC/EN 61008

Marking: according to EN 61008

Number of poles	Rated residual current	Rated current	Order details		Bbn 8012542	Price 1 piece	Price group	Weight 1 piece	Pack unit
	$I_{\Delta n}$ mA	I_n A	Type code	Order code	EAN			kg	pc.
4	30	25	F204 A-25/0.03	2CSF204123R1250	820109			0.375	1/3
		40	F204 A-40/0.03	2CSF204123R1400	820208		0.375	1/3	
		63	F204 A-63/0.03	2CSF204123R1630	820307		0.375	1/3	
		80	F204 A-80/0.03	2CSF204123R1800	918608		0.405	1/3	
		100	F204 A-100/0.03	2CSF204123R1900	918707		0.405	1/3	
		125	F204 A-125/0.03	2CSF204123R1950	967705		0.500	1	
	100	25	25	F204 A-25/0.1	2CSF204123R2250	820406		0.375	1/3
			40	F204 A-40/0.1	2CSF204123R2400	820505		0.375	1/3
			63	F204 A-63/0.1	2CSF204123R2630	820604		0.375	1/3
	300	25	25	F204 A-25/0.3	2CSF204123R3250	820703		0.375	1/3
			40	F204 A-40/0.3	2CSF204123R3400	820802		0.375	1/3
			63	F204 A-63/0.3	2CSF204123R3630	820901		0.375	1/3
80			F204 A-80/0.3	2CSF204123R3800	918806		0.405	1/3	
100			F204 A-100/0.3	2CSF204123R3900	918905		0.405	1/3	
125			F204 A-125/0.3	2CSF204123R3950	967804		0.500	1	
500	25	25	F204 A-25/0.5	2CSF204123R4250	821007		0.375	1/3	
		40	F204 A-40/0.5	2CSF204123R4400	821106		0.375	1/3	
		63	F204 A-63/0.5	2CSF204123R4630	821205		0.375	1/3	

AC

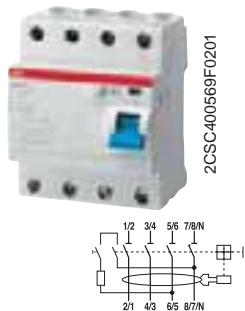

F 200 AP-R, AC type

Function: protection against the effects of sinusoidal alternating earth fault currents, providing the best compromise between safety and continuity in the service thanks to the resistance to unwanted trippings; protection against indirect contacts and additional protection against direct ($I_{\Delta n}=30$ mA) contacts; command and isolation of resistive and inductive circuits.

Application: residential, commercial, industrial.

Standard: IEC/EN 61008

Surge current resistance (wave 8/20)=3000 A

Marking: according to EN 61008

Number of poles	Rated residual current	Rated current	Order details	Bbn 8012542	Price 1 piece	Price group	Weight 1 piece	Pack unit
	$I_{\Delta n}$ mA	In A	Type code	Order code	EAN		kg	pc.
2	30	25	F202 AC-25/0.03 AP-R	2CSF202301R1250	785705		0.225	1/6
		40	F202 AC-40/0.03 AP-R	2CSF202301R1400	823704		0.225	1/6
		63	F202 AC-63/0.03 AP-R	2CSF202301R1630	785804		0.225	1/6

4	30	25	F204 AC-25/0.03 AP-R	2CSF204301R1250	785903		0.375	1/3
		40	F204 AC-40/0.03 AP-R	2CSF204301R1400	823803		0.375	1/3
		63	F204 AC-63/0.03 AP-R	2CSF204301R1630	786009		0.375	1/3

A

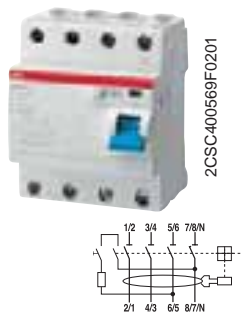

F 200 AP-R, A type

Function: protection against the effects of sinusoidal alternating and direct pulsating earth fault currents, providing the best compromise between safety and continuity in the service thanks to the resistance to unwanted trippings; protection against indirect contacts and additional protection against direct ($I_{\Delta n}=30$ mA) contacts; command and isolation of resistive and inductive circuits.

Application: residential, commercial, industrial.

Standard: IEC/EN 61008

Surge current resistance (wave 8/20)=3000 A

Marking: according to EN 61008

Number of poles	Rated residual current $I_{\Delta n}$ mA	Rated current I_n A	Order details	Bbn 8012542	Price 1 piece	Price group	Weight 1 piece kg	Pack unit pc.
			Type code	Order code	EAN			
2	30	25	F202 A-25/0.03 AP-R	2CSF202401R1250	785101		0.225	1/6
		40	F202 A-40/0.03 AP-R	2CSF202401R1400	785200		0.225	1/6
		63	F202 A-63/0.03 AP-R	2CSF202401R1630	785309		0.225	1/6
		80	F202 A-80/0.03 AP-R	2CSF202401R1800	916406		0.225	1/6
		100	F202 A-100/0.03 AP-R	2CSF202401R1900	916505		0.225	1/6

4	30	25	F204 A-25/0.03 AP-R	2CSF204401R1250	785408		0.375	1/3
		40	F204 A-40/0.03 AP-R	2CSF204401R1400	785507		0.375	1/3
		63	F204 A-63/0.03 AP-R	2CSF204401R1630	785606		0.375	1/3
		80	F204 A-80/0.03 AP-R	2CSF204401R1800	919407		0.405	1/3
		100	F204 A-100/0.03 AP-R	2CSF204401R1900	919506		0.405	1/3
		125	F204 A-125/0.03 AP-R	2CSF204401R1950	967903		0.500	1

AC

F 200 AC selective type

Function: protection against the effects of sinusoidal alternating earth fault currents with an intentional tripping delay, which permits to realize the selectivity with downstream instantaneous devices (for more information about selectivity see the technical guide); protection against indirect contacts; command and isolation of resistive and inductive circuits.

Application: commercial, industrial.

Standard: IEC/EN 61008

Surge current resistance (wave 8/20)=5000 A

Marking: according to EN 61008

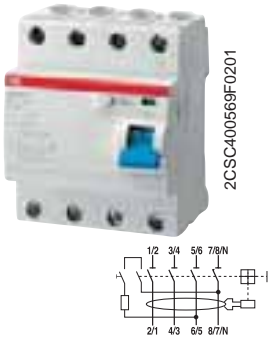

Number of poles	Rated residual current I Δ n mA	Rated current In A	Order details		Bbn 8012542	Price 1 piece	Price group	Weight 1 piece	Pack unit
			Type code	Order code	EAN			kg	pc.
2	100	40	F202 AC S-40/0.1	2CSF202901R2400	821304			0.225	1/6
		63	F202 AC S-63/0.1	2CSF202901R2630	821403			0.225	1/6
	300	40	F202 AC S-40/0.3	2CSF202901R3400	821502			0.225	1/6
		63	F202 AC S-63/0.3	2CSF202901R3630	821601			0.225	1/6
	500	40	F202 AC S-40/0.5	2CSF202901R4400	821700			0.225	1/6
		63	F202 AC S-63/0.5	2CSF202901R4630	821809			0.225	1/6
1000	40	F202 AC S-40/1	2CSF202901R5400	821908			0.225	1/6	
	63	F202 AC S-63/1	2CSF202901R5630	822004			0.225	1/6	

4	100	40	F204 AC S-40/0.1	2CSF204901R2400	822103			0.375	1/3
		63	F204 AC S-63/0.1	2CSF204901R2630	822202			0.375	1/3
	300	40	F204 AC S-40/0.3	2CSF204901R3400	822301			0.375	1/3
		63	F204 AC S-63/0.3	2CSF204901R3630	822400			0.375	1/3
	500	40	F204 AC S-40/0.5	2CSF204901R4400	822509			0.375	1/3
		63	F204 AC S-63/0.5	2CSF204901R4630	822608			0.375	1/3
1000	40	F204 AC S-40/1	2CSF204901R5400	822707			0.375	1/3	
	63	F204 AC S-63/1	2CSF204901R5630	822806			0.375	1/3	

A



F 200 A selective type

Function: protection against the effects of sinusoidal alternating and direct pulsating earth fault currents with an intentional tripping delay, which permits to realize the selectivity with downstream instantaneous devices (for more information about selectivity see the technical guide); protection against indirect contacts; command and isolation of resistive and inductive circuits.

Application: commercial, industrial.

Standard: IEC/EN 61008

Surge current resistance (wave 8/20)=5000 A

Marking: according to EN 61008

Number of poles	Rated residual current I Δ n mA	Rated current In A	Order details Type code	Order code	Bbn 8012542 EAN	Price 1 piece	Price group	Weight 1 piece kg	Pack unit pc.
2	100	40	F202 A S-40/0.1	2CSF202201R2400	822905			0.225	1/6
		63	F202 A S-63/0.1	2CSF202201R2630	823001			0.225	1/6
		100	F202 A S-100/0.1	2CSF202201R2900	916000			0.225	1/6
	300	40	F202 A S-40/0.3	2CSF202201R3400	784302			0.225	1/6
		63	F202 A S-63/0.3	2CSF202201R3630	784401			0.225	1/6
		100	F202 A S-100/0.3	2CSF202201R3900	916109			0.225	1/6
	500	40	F202 A S-40/0.5	2CSF202201R4400	784500			0.225	1/6
		63	F202 A S-63/0.5	2CSF202201R4630	784609			0.225	1/6
		100	F202 A S-100/0.5	2CSF202201R4900	916208			0.225	1/6
1000	40	F202 A S-40/1	2CSF202201R5400	823100			0.225	1/6	
	63	F202 A S-63/1	2CSF202201R5630	823209			0.225	1/6	
	100	F202 A S-100/1	2CSF202201R5900	916307			0.225	1/6	

4	100	40	F204 A S-40/0.1	2CSF204201R2400	823308			0.375	1/3
		63	F204 A S-63/0.1	2CSF204201R2630	823407			0.375	1/3
		100	F204 A S-100/0.1	2CSF204201R2900	919001			0.405	1/3
	300	40	F204 A S-40/0.3	2CSF204201R3400	784708			0.375	1/3
		63	F204 A S-63/0.3	2CSF204201R3630	784807			0.375	1/3
		100	F204 A S-100/0.3	2CSF204201R3900	919100			0.405	1/3
	500	125	F204 A S-125/0.3	2CSF204201R3950	968207			0.500	1
		40	F204 A S-40/0.5	2CSF204201R4400	784906			0.375	1/3
		63	F204 A S-63/0.5	2CSF204201R4630	785002			0.375	1/3
	1000	100	F204 A S-100/0.5	2CSF204201R4900	919209			0.405	1/3
		125	F204 A S-125/0.5	2CSF204201R4950	968405			0.500	1
		40	F204 A S-40/1	2CSF204201R5400	823506			0.375	1/3
	1000	63	F204 A S-63/1	2CSF204201R5630	823605			0.375	1/3
		100	F204 A S-100/1	2CSF204201R5900	919308			0.405	1/3

A

F 200 A type for high frequency (400 Hz)

Function: protection against the effects of sinusoidal alternating and direct pulsating earth fault currents; protection against indirect contacts and additional protection against direct (with $I_{dn}=30$ mA) contacts; command and isolation of resistive and inductive circuits.

Advantages: increasing the frequency generates an increase of the magnetic reluctance of the toroidal transformer of standard RCCB and what follows is the value of the increasing operating residual current at 400 Hz reaching values 3 or more times higher than those of the residual current at 50Hz. The RCCB F 200 400 Hz guarantees protection against indirect contacts and additional protection against direct (with $I_{dn}=30$ mA) contacts considering that the operating residual current doesn't increase with the increase of the network frequency.

Application: commercial, industrial.

Standard: IEC/EN 61008

Marking: according to EN 61008



2CSF204197R1400

Number of poles	Rated residual current $I_{\Delta n}$ mA	Rated current In A	Order details		Bbn 8012542	Price 1 piece	Price group	Weight 1 piece kg	Pack unit pc.
			Type code	Order code					
4	30	25	F204 A-25/0.03 400Hz	2CSF204197R1250	968603			0.375	1/3
		40	F204 A-40/0.03 400Hz	2CSF204197R1400					



F 200 B type for smooth DC earth fault current

Function: protection against the effects of sinusoidal alternating, direct pulsating and pulsating DC or smooth DC earth fault currents; protection against indirect contacts and additional protection against direct (with $I_{dn}=30\text{ mA}$) contacts; command and isolation of resistive and inductive circuits.

Application: industrial.

Standard: IEC/EN 61008, IEC 62423

Marking: according to EN 61008

Number of poles	Rated residual current	Rated current	Order details		Bbn	Price	Price	Weight	Pack
	$I_{\Delta n}$ mA	I_n A	Type code	Order code	8012542	1 piece	group	1 piece	unit
					EAN			kg	pc.
4	30	40	F204 B-40/0.03	2CSF204501R1400	988403			0.500	1
		63	F204 B-63/0.03	2CSF204501R1630	988502			0.500	1
	300	63	F204 B-63/0.3	2CSF204501R3630	989004			0.500	1

F 200 B selective type for smooth DC earth fault current

Function: protection against the effects of sinusoidal alternating, direct pulsating and pulsating DC or smooth DC earth fault currents with an intentional tripping delay, which permits to realize the selectivity with downstream instantaneous devices (for more information about selectivity see the technical guide); protection against indirect contacts; command and isolation of resistive and inductive circuits.

Application: industrial.

Standard: IEC/EN 61008, IEC 62423

Surge current resistance (wave 8/20)=5000A

Marking: according to EN 61008

Number of poles	Rated residual current	Rated current	Order details		Bbn	Price	Price	Weight	Pack
	$I_{\Delta n}$ mA	I_n A	Type code	Order code	8012542	1 piece	group	1 piece	unit
					EAN			kg	pc.
4	300	63	F204 B S-63/0.3	2CSF204801R3630	989301			0.500	1

TECHNICAL FEATURES			
Standards			
Electrical features	Operating characteristic: type		
	Poles		
	Rated sensitivity $I_{\Delta n}$		A
	Size		A
	Rated voltage U_N		V
	Insulation voltage U_i		V
	Max. operating voltage of circuit test		V
	Min. operating voltage of circuit test		V
	Rated frequency		Hz
	Rated breaking capacity (I _{cn}) acc. to IEC /EN 61009		A
	Rated breaking capacity (I _{cn}) acc. to IEC/EN 60947-2		A
	Rated residual breaking capacity $I_{\Delta m}$		kA
	Rated impulse withstand voltage (1.2/50) U_{imp}		kV
	Dielectric test voltage at ind. freq. for 1 min.		kV
	Surge current resistance (wave 8/20)		A
Mechanical features	Toggle		
	Electrical life		
	Mechanical life		
	Protection degree	housing terminals	
	Tropicalization acc. to IEC /EN 60068-2	humid heat	°C/RH
		constant climatic conditions	°C/RH
		variable climatic conditions	°C/RH
Ambient temperature (with daily average $\leq +35$ °C)		°C	
Storage temperature		°C	
Installation	Terminal type	2P	
		3P/4P $I_n = 25$ and 40 A	
		3P/4P $I_n = 63$ A	
	Terminal size for cables	2P	mm ²
		3P/4P $I_n = 25$ and 40 A	mm ²
		3P/4P $I_n = 63$ A	mm ²
	Tightening torque	2P	N*m
3P/4P $I_n = 25$ and 40 A		N*m	
3P/4P $I_n = 63$ A		N*m	
Mounting			
Dimensions and weight	Dimensions (H x D x W)	2P	mm
		3P/4P $I_n = 25$ and 40 A	mm
		3P/4P $I_n = 63$ A	mm
	Weight	2P	g
		3P/4P $I_n = 25$ and 40 A	g
3P/4P $I_n = 63$ A		g	
Combination with MCBs	Combinable with:		
	S 200		
	S 200 M		
	S 200 P		

① prior to connection of aluminium conductors (≥ 4 mm²) ensure that their contact points are cleaned, brushed and coated with grease

System pro M compact® RCD-blocks DDA 200 series

DDA 200



3

DDA200 AC	DDA200 A	DDA200 A AE	DDA200 B	DDA200 AC AP-R	DDA200 A AP-R	DDA200 AC S	DDA200 A S
IEC/EN 61009 Ann.G (and IEC 62423 for B type)							
AC	A	A	B	AC	A	AC	A
2P, 3P, 4P		4P		2P, 3P, 4P			
0.01-0.03-0.1-0.3-0.5-1		0.03-0.3-0.5-1		0.03		0.1-0.3-0.5-1	
25, 40, 63		63		25, 40, 63		63	
230/400 - 240/415							
500							
254 (440 for 3P and 4P)		264 (440 for 3P)		254 (440 for 3P and 4P)			
110 (195 for 3P and 4P)		184 (310 for 3P)		110 (195 for 3P and 4P)			
50...60							
Icn of the associated MCB							
Icu of the associated MCB							
Icn of the associated MCB							
5							
2.5							
250		3000 (5000 for selective type)		3000		5000	
blue							
10000							
20000							
IP4X							
IP2X							
28 cycles with 55/95...100							
23/83 - 40/93 - 55/20							
25/95 - 40/95							
-25...+55							
-40...+70							
failsafe bi-directional cylinder-lift terminal (shock protected) ①							
cage (shock protected)							
failsafe bi-directional cylinder-lift terminal (shock protected) ①							
(rigid and flexible) up to 25							
(rigid and flexible) up to 16							
(rigid and flexible) up to 25							
2.8							
1.2							
2.8							
on DIN rail EN 60715 (35 mm) by means of fast clip device							
85 x 69 x 70							
85 x 69 x 70							
85 x 69 x 140							
175							
175							
325							
yes							
yes							
yes							

AC

DDA 200 AC type

Function: RCD-block for assembly on site with MCBs S 200 series. Protection against the effects of sinusoidal alternating earth fault currents; protection against indirect contacts and additional protection against direct (with $I_{\Delta n}=30$ mA) contacts.

Application: residential, commercial, industrial.

Standard: IEC/EN 61009 Ann. G

3



2CSC400163F0201

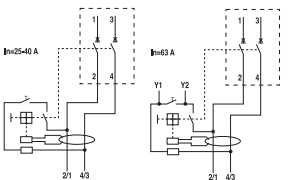

2CSC400164F0201

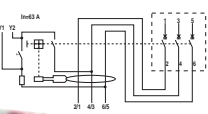
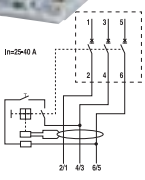

2CSC400165F0201

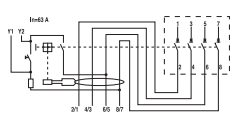
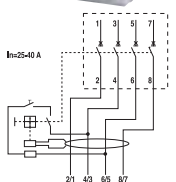

Number of poles	Rated residual current $I_{\Delta n}$ mA	Rated residual current In A	Order details		Bbn 8012542	Price 1 piece	Price group	Weight 1 piece kg	Pack unit pc.	
			Type code	Order code						
2	10	25	DDA202 AC-25/0.01	2CSB202001R0250	791003			0.200	1	
			DDA202 AC-25/0.03	2CSB202001R1250	791102			0.200	1	
			DDA202 AC-40/0.03	2CSB202001R1400	791201			0.200	1	
	30	25	DDA202 AC-63/0.03	2CSB202001R1630	791300			0.200	1	
			DDA202 AC-25/0.1	2CSB202001R2250	791409			0.200	1	
			DDA202 AC-40/0.1	2CSB202001R2400	791508			0.200	1	
	63	25	DDA202 AC-63/0.1	2CSB202001R2630	791607			0.200	1	
			DDA202 AC-25/0.3	2CSB202001R3250	791706			0.200	1	
			DDA202 AC-40/0.3	2CSB202001R3400	791805			0.200	1	
	500	25	DDA202 AC-63/0.3	2CSB202001R3630	791904			0.200	1	
			DDA202 AC-25/0.5	2CSB202001R4250	790200			0.200	1	
			DDA202 AC-40/0.5	2CSB202001R4400	792109			0.200	1	
63	25	DDA202 AC-63/0.5	2CSB202001R4630	792208			0.200	1		
		DDA202 AC-25/1	2CSB202001R5250	808305			0.200	1		
		DDA202 AC-40/1	2CSB202001R5400	808404			0.200	1		
2000	63	DDA202 AC-63/1	2CSB202001R5630	792307			0.200	1		
		DDA202 AC-63/2	2CSB202001R6630	792406			0.200	1		
3	30	25	DDA203 AC-25/0.03	2CSB203001R1250	792505			0.200	1	
			DDA203 AC-40/0.03	2CSB203001R1400	792604			0.200	1	
			DDA203 AC-63/0.03	2CSB203001R1630	792703			0.350	1	
	100	25	DDA203 AC-25/0.1	2CSB203001R2250	792802			0.200	1	
			DDA203 AC-40/0.1	2CSB203001R2400	792901			0.200	1	
			DDA203 AC-63/0.1	2CSB203001R2630	793007			0.350	1	
	300	25	DDA203 AC-25/0.3	2CSB203001R3250	793106			0.200	1	
			DDA203 AC-40/0.3	2CSB203001R3400	793205			0.200	1	
			DDA203 AC-63/0.3	2CSB203001R3630	793304			0.350	1	
	500	25	DDA203 AC-25/0.5	2CSB203001R4250	793403			0.200	1	
			DDA203 AC-40/0.5	2CSB203001R4400	793502			0.200	1	
			DDA203 AC-63/0.5	2CSB203001R4630	793601			0.350	1	
	1000	25	DDA203 AC-25/1	2CSB203001R5250	808503			0.200	1	
			DDA203 AC-40/1	2CSB203001R5400	808602			0.200	1	
			DDA203 AC-63/1	2CSB203001R5630	793700			0.350	1	
	2000	63	DDA203 AC-63/2	2CSB203001R6630	793809			0.350	1	
4	30	25	DDA204 AC-25/0.03	2CSB204001R1250	793908			0.200	1	
			DDA204 AC-40/0.03	2CSB204001R1400	794004			0.200	1	
			DDA204 AC-63/0.03	2CSB204001R1630	794103			0.350	1	
	100	25	DDA204 AC-25/0.1	2CSB204001R2250	794202			0.200	1	
			DDA204 AC-40/0.1	2CSB204001R2400	794301			0.200	1	
			DDA204 AC-63/0.1	2CSB204001R2630	794400			0.350	1	
	300	25	DDA204 AC-25/0.3	2CSB204001R3250	794509			0.200	1	
			DDA204 AC-40/0.3	2CSB204001R3400	794608			0.200	1	
			DDA204 AC-63/0.3	2CSB204001R3630	794707			0.350	1	
	500	25	DDA204 AC-25/0.5	2CSB204001R4250	794806			0.200	1	
			DDA204 AC-40/0.5	2CSB204001R4400	794905			0.200	1	
			DDA204 AC-63/0.5	2CSB204001R4630	795001			0.350	1	
	1000	25	DDA204 AC-25/1	2CSB204001R5250	808701			0.200	1	
			DDA204 AC-40/1	2CSB204001R5400	808800			0.200	1	
			DDA204 AC-63/1	2CSB204001R5630	795100			0.350	1	
	2000	63	DDA204 AC-63/2	2CSB204001R6630	795209			0.350	1	

① version with test button working at 115VAC - 127VAC is available on request
 ② provided with additional terminals for remote tripping

A

DDA 200 A type

Function: RCD-block for assembly on site with MCBs S 200 series. Protection against the effects of sinusoidal alternating and direct pulsating earth fault currents; protection against indirect contacts and additional protection against direct (with $I_{\Delta n}=30$ mA) contacts.

Application: residential, commercial, industrial.

Standard: IEC/EN 61009 Ann. G

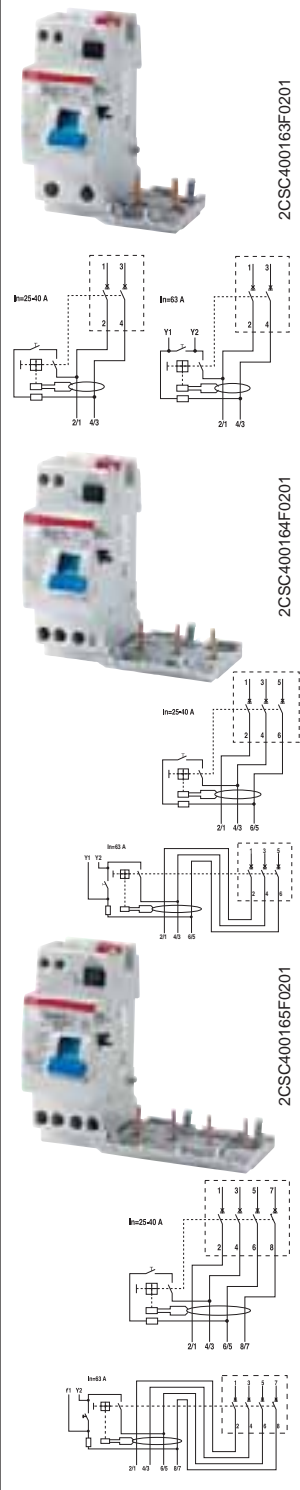

Number of poles	Rated residual current $I_{\Delta n}$ mA	Rated current I_n A	Order details		Bbn 8012542	Price 1 piece	Price group	Weight 1 piece kg	Pack unit pc.	
			Type code	Order code						EAN
2	10	25	DDA202 A-25/0.01	2CSB202101R0250	795308			0.200	1	
		30	DDA202 A-25/0.03	2CSB202101R1250	795407			0.200	1	
		40	DDA202 A-40/0.03	2CSB202101R1400	795506			0.200	1	
	63 ②	25	DDA202 A-63/0.03	2CSB202101R1630	795605			0.200	1	
			40	DDA202 A-25/0.1	2CSB202101R2250	795704			0.200	1
			40	DDA202 A-40/0.1	2CSB202101R2400	795803			0.200	1
	63 ②	25	DDA202 A-63/0.1	2CSB202101R2630	795902			0.200	1	
			300	25	DDA202 A-25/0.3	2CSB202101R3250	796008		0.200	1
			40	DDA202 A-40/0.3	2CSB202101R3400	796107			0.200	1
	63 ②	25	DDA202 A-63/0.3	2CSB202101R3630	796206			0.200	1	
			500	25	DDA202 A-25/0.5	2CSB202101R4250	796305		0.200	1
			40	DDA202 A-40/0.5	2CSB202101R4400	796404			0.200	1
63 ②	25	DDA202 A-63/0.5	2CSB202101R4630	796503			0.200	1		
		1000	25	DDA202 A-25/1	2CSB202101R5250	808909		0.200	1	
		40	DDA202 A-40/1	2CSB202101R5400	809005			0.200	1	
63 ②	25	DDA202 A-63/1	2CSB202101R5630	796602			0.200	1		
		3	30	25	DDA203 A-25/0.03	2CSB203101R1250	796701		0.200	1
				40	DDA203 A-40/0.03	2CSB203101R1400	796800		0.200	1
63 ②	DDA203 A-63/0.03			2CSB203101R1630	796909		0.350	1		
100	25	DDA203 A-25/0.1	2CSB203101R2250	797005			0.200	1		
		40	DDA203 A-40/0.1	2CSB203101R2400	797104		0.200	1		
		63 ②	DDA203 A-63/0.1	2CSB203101R2630	797203		0.350	1		
300	25	DDA203 A-25/0.3	2CSB203101R3250	797302			0.200	1		
		40	DDA203 A-40/0.3	2CSB203101R3400	797401		0.200	1		
		63 ②	DDA203 A-63/0.3	2CSB203101R3630	797500		0.350	1		
500	25	DDA203 A-25/0.5	2CSB203101R4250	797609			0.200	1		
		40	DDA203 A-40/0.5	2CSB203101R4400	797708		0.200	1		
		63 ②	DDA203 A-63/0.5	2CSB203101R4630	797807		0.350	1		
1000	25	DDA203 A-25/1	2CSB203101R5250	809104			0.200	1		
		40	DDA203 A-40/1	2CSB203101R5400	809203		0.200	1		
		63 ②	DDA203 A-63/1	2CSB203101R5630	797906		0.350	1		
4	30	25	DDA204 A-25/0.03	2CSB204101R1250	798002			0.200	1	
		40	DDA204 A-40/0.03	2CSB204101R1400	798101		0.200	1		
		63 ① ②	DDA204 A-63/0.03	2CSB204101R1630	798200		0.350	1		
	100	25	DDA204 A-25/0.1	2CSB204101R2250	798309			0.200	1	
			40	DDA204 A-40/0.1	2CSB204101R2400	798408		0.200	1	
			63 ②	DDA204 A-63/0.1	2CSB204101R2630	798507		0.350	1	
	300	25	DDA204 A-25/0.3	2CSB204101R3250	798606			0.200	1	
			40	DDA204 A-40/0.3	2CSB204101R3400	798705		0.200	1	
			63 ②	DDA204 A-63/0.3	2CSB204101R3630	798804		0.350	1	
	500	25	DDA204 A-25/0.5	2CSB204101R4250	798903			0.200	1	
			40	DDA204 A-40/0.5	2CSB204101R4400	799009		0.200	1	
			63 ②	DDA204 A-63/0.5	2CSB204101R4630	799108		0.350	1	
1000	25	DDA204 A-25/1	2CSB204101R5250	809302			0.200	1		
		40	DDA204 A-40/1	2CSB204101R5400	809401		0.200	1		
		63 ②	DDA204 A-63/1	2CSB204101R5630	799207		0.350	1		

① version with test button working at 115 VAC-127 VAC is available on request
② provided with additional terminals for remote tripping

A

DDA 200 AE, A type

Function: RCD-block for assembly on site with MCBs S 200 series. Protection against the effects of sinusoidal alternating and direct pulsating earth fault currents; the RCD-block is provided with two additional terminals to be used in emergency circuits for remote opening in positive safety; protection against indirect contacts and additional protection against direct (with $I_{\Delta n}=30$ mA) contacts.

Application: commercial, industrial.

Standard: IEC/EN 61009 Ann. G

3



2CSC400163F0201

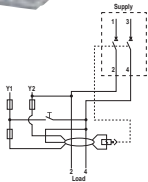

2CSC400563F0201

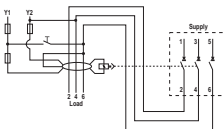

2CSC400562F0201

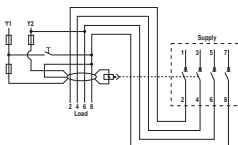

Number of poles	Rated residual current $I_{\Delta n}$ mA	Rated current In A	Order details		Bbn 8012542	Price 1 piece	Price group	Weight 1 piece kg	Pack unit pc.
			Type code	Order code					
2	30	63	DDA202 A-63/0.03 AE	2CSB202701R1630	801702			0.200	1
	300	63	DDA202 A-63/0.3 AE	2CSB202701R3630	801801			0.200	1
	500	63	DDA202 A-63/0.5 AE	2CSB202701R4630	801900			0.200	1
	1000	63	DDA202 A-63/1 AE	2CSB202701R5630	802006			0.200	1

3	30	63	DDA203 A-63/0.03 AE	2CSB203701R1630	802105			0.350	1
	300	63	DDA203 A-63/0.3 AE	2CSB203701R3630	802204			0.350	1
	500	63	DDA203 A-63/0.5 AE	2CSB203701R4630	802303			0.350	1
	1000	63	DDA203 A-63/1 AE	2CSB203701R5630	802402			0.350	1

4	30	63	DDA204 A-63/0.03 AE	2CSB204701R1630	802501			0.350	1
	300	63	DDA204 A-63/0.3 AE	2CSB204701R3630	802600			0.350	1
	500	63	DDA204 A-63/0.5 AE	2CSB204701R4630	802709			0.350	1
	1000	63	DDA204 A-63/1 AE	2CSB204701R5630	802808			0.350	1

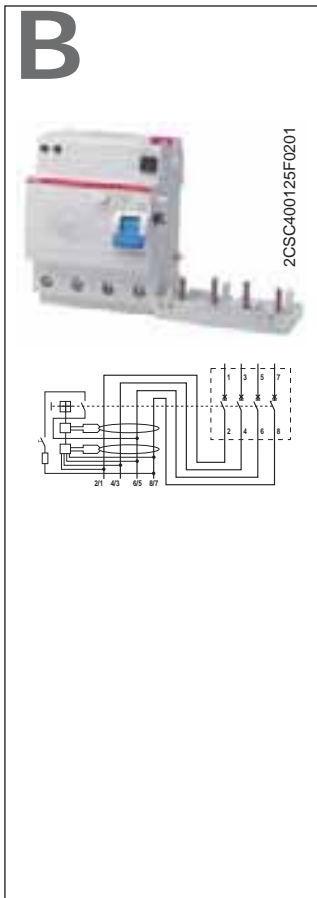

DDA 200 B type for smooth DC earth fault current

Function: RCD-block for assembly on site with MCBs S 200 series. Protection against the effects of sinusoidal alternating, direct pulsating and pulsating DC or smooth DC earth fault currents; protection against indirect contacts and additional protection against direct (with $I_{\Delta n}=30$ mA) contacts.

Application: industrial.

Standard: IEC/EN 61009 Ann. G, IEC 62423

Number of poles	Rated residual current $I_{\Delta n}$ mA	Rated current I_n A	Order details		Bbn 8012542	Price 1 piece	Price group	Weight 1 piece kg	Pack unit pc.
			Type code	Order code					
4	30	63	DDA204 B-63/0.03	2CSB204501R1630	987505			0.325	1
	300	63	DDA204 B-63/0.3	2CSB204501R3630	987604			0.325	1

3

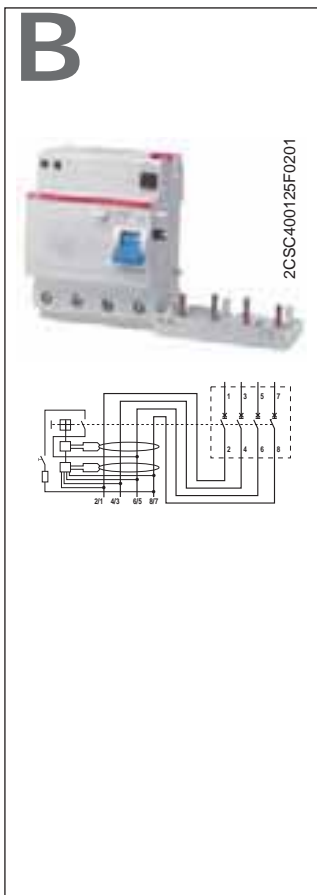

DDA 200 B selective type for smooth DC earth fault current

Function: RCD-block for assembly on site with MCBs S 200 series. Protection against the effects of sinusoidal alternating, direct pulsating and pulsating DC or smooth DC earth fault currents with an intentional tripping delay, which permits to realize the selectivity with downstream instantaneous devices (for more information about selectivity see the technical guide).

Application: industrial.

Standard: IEC/EN 61009 Ann. G, IEC 62423

Number of poles	Rated residual current $I_{\Delta n}$ mA	Rated current I_n A	Order details		Bbn 8012542	Price 1 piece	Price group	Weight 1 piece kg	Pack unit pc.
			Type code	Order code					
4	300	63	DDA204 B S-63/0.3	2CSB204801R3630	987901			0.325	1

AC



2CSC400163F0201

3

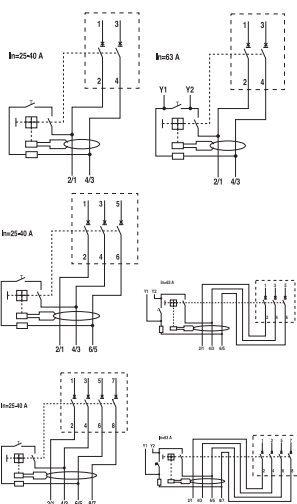

DDA 200 AP-R, AC type

Function: RCD-block for assembly on site with MCBs S 200 series. Protection against the effects of sinusoidal alternating earth fault currents, providing the best compromise between safety and continuity in the service thanks to the resistance to unwanted trippings; protection against indirect contacts and additional protection against direct (with $I_{\Delta n}=30$ mA) contacts.

Application: residential, commercial, industrial.

Standard: IEC/EN 61009 Ann. G

Surge current resistance (wave 8/20)=3000 A

Number of poles	Rated residual current $I_{\Delta n}$ mA	Rated current I_n A	Order details Type code	Order code	Bbn 8012542	Price 1 piece	Price group	Weight 1 piece kg	Pack unit pc.
2	30	25	DDA202 AC-25/0.03 AP-R 2CSB202301R1250		800507			0.200	1
		40	DDA202 AC-40/0.03 AP-R 2CSB202301R1400		800606		0.200	1	
		63 ①	DDA202 AC-63/0.03 AP-R 2CSB202301R1630		800705		0.200	1	
3	30	25	DDA203 AC-25/0.03 AP-R 2CSB203301R1250		810704			0.200	1
		40	DDA203 AC-40/0.03 AP-R 2CSB203301R1400		810803		0.200	1	
		63 ①	DDA203 AC-63/0.03 AP-R 2CSB203301R1630		810902		0.350	1	
4	30	25	DDA204 AC-25/0.03 AP-R 2CSB204301R1250		800804			0.200	1
		40	DDA204 AC-40/0.03 AP-R 2CSB204301R1400		800903		0.200	1	
		63 ①	DDA204 AC-63/0.03 AP-R 2CSB204301R1630		801009		0.350	1	

① provided with additional terminals for remote tripping

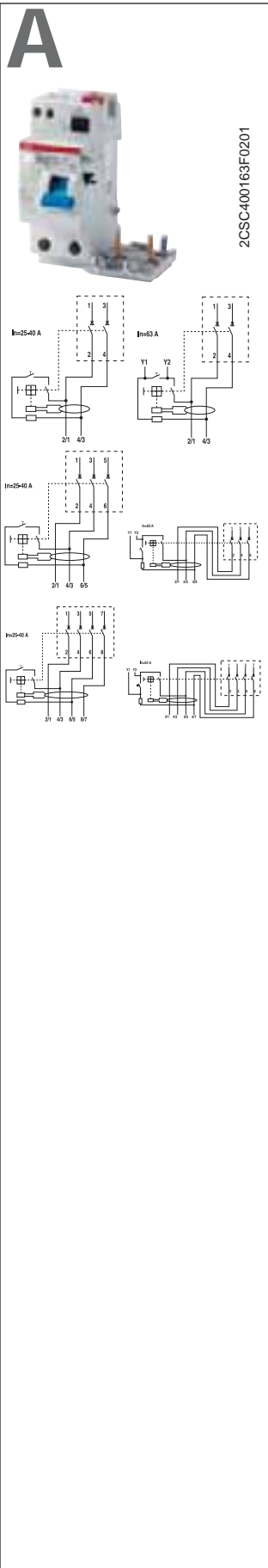

DDA 200 AP-R, A type

Function: RCD-block for assembly on site with MCBs S 200 series. Protection against the effects of sinusoidal alternating and direct pulsating earth fault currents, providing the best compromise between safety and continuity in the service thanks to the resistance to unwanted trippings; protection against indirect contacts and additional protection against direct (with $I\Delta n=30\text{ mA}$) contacts.

Application: residential, commercial, industrial.

Standard: IEC/EN 61009 Ann. G

Surge current resistance (wave 8/20)=3000 A

Number of poles	Rated residual current $I\Delta n$ mA	Rated current I_n A	Order details		Bbn	Price	Price	Weight	Pack
			Type code	Order code	8012542	1 piece	group	1 piece	unit
					EAN			kg	pc.
2	30	25	DDA202 A-25/0.03 AP-R	2CSB202401R1250	801108			0.200	1
		40	DDA202 A-40/0.03 AP-R	2CSB202401R1400	801207			0.200	1
		63 ①	DDA202 A-63/0.03 AP-R	2CSB202401R1630	801306			0.200	1
3	30	25	DDA203 A-25/0.03 AP-R	2CSB203401R1250	811008			0.200	1
		40	DDA203 A-40/0.03 AP-R	2CSB203401R1400	811107			0.200	1
		63 ①	DDA203 A-63/0.03 AP-R	2CSB203401R1630	811206			0.350	1
4	30	25	DDA204 A-25/0.03 AP-R	2CSB204401R1250	801405			0.200	1
		40	DDA204 A-40/0.03 AP-R	2CSB204401R1400	801504			0.200	1
		63 ①	DDA204 A-63/0.03 AP-R	2CSB204401R1630	801603			0.350	1

① provided with additional terminals for remote tripping

AC

DDA 200 AC selective type

Function: RCD-block for assembly on site with MCBs S 200 series. Protection against the effects of sinusoidal alternating earth fault currents with an intentional tripping delay, which permits to realize the selectivity with downstream instantaneous devices (for more information about selectivity see the technical guide).

Application: commercial, industrial.

Standard: IEC/EN 61009 Ann. G

Surge current resistance (wave 8/20)=5000 A

3



2CSC400163F0201

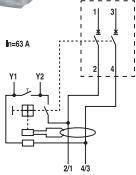

2CSC400563F0201

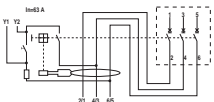

2CSC400562F0201

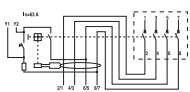

Number of poles	Rated residual current IΔn mA	Rated current In A	Order details		Bbn 8012542	Price 1 piece	Price group	Weight 1 piece kg	Pack unit pc.
			Type code	Order code					
2	100	63	DDA202 AC S-63/0.1	2CSB202901R2630	809500			0.200	1
	300	63	DDA202 AC S-63/0.3	2CSB202901R3630	809609			0.200	1
	500	63	DDA202 AC S-63/0.5	2CSB202901R4630	809708			0.200	1
	1000	63	DDA202 AC S-63/1	2CSB202901R5630	809807			0.200	1

3	100	63	DDA203 AC S-63/0.1	2CSB203901R2630	809906			0.350	1
	300	63	DDA203 AC S-63/0.3	2CSB203901R3630	810001			0.350	1
	500	63	DDA203 AC S-63/0.5	2CSB203901R4630	810100			0.350	1
	1000	63	DDA203 AC S-63/1	2CSB203901R5630	810209			0.350	1

4	100	63	DDA204 AC S-63/0.1	2CSB204901R2630	810308			0.350	1
	300	63	DDA204 AC S-63/0.3	2CSB204901R3630	810407			0.350	1
	500	63	DDA204 AC S-63/0.5	2CSB204901R4630	810506			0.350	1
	1000	63	DDA204 AC S-63/1	2CSB204901R5630	810605			0.350	1

Attention:

All DDA 200 AC S are provided with additional terminals for remote tripping

A



2CSC400163F0201

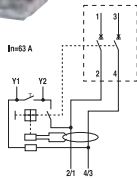

2CSC400563F0201

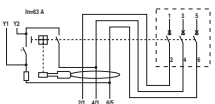

2CSC400562F0201

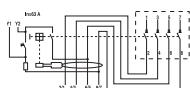

DDA 200 A selective type

Function: RCD-block for assembly on site with MCBs S 200 series. Protection against the effects of sinusoidal alternating and direct pulsating earth fault currents with an intentional tripping delay, which permits to realize the selectivity with downstream instantaneous devices (for more information about selectivity see the technical guide).

Application: commercial, industrial.

Standard: IEC/EN 61009 Ann. G

Surge current resistance (wave 8/20)=5000 A

Number of poles	Rated residual current I Δ n mA	Rated current In A	Order details		Bbn 8012542	Price 1 piece	Price group	Weight 1 piece kg	Pack unit pc.
			Type code	Order code					
2	100	63	DDA202 A S-63/0.1	2CSB202201R2630	799306			0.200	1
	300	63	DDA202 A S-63/0.3	2CSB202201R3630	799405			0.200	1
	500	63	DDA202 A S-63/0.5	2CSB202201R4630	799504			0.200	1
	1000	63	DDA202 A S-63/1	2CSB202201R5630	799603			0.200	1

3	100	63	DDA203 A S-63/0.1	2CSB203201R2630	799702			0.350	1
	300	63	DDA203 A S-63/0.3	2CSB203201R3630	799801			0.350	1
	500	63	DDA203 A S-63/0.5	2CSB203201R4630	799900			0.350	1
	1000	63	DDA203 A S-63/1	2CSB203201R5630	800002			0.350	1

4	100	63	DDA204 A S-63/0.1	2CSB204201R2630	800101			0.350	1
	300	63	DDA204 A S-63/0.3	2CSB204201R3630	800200			0.350	1
	500	63	DDA204 A S-63/0.5	2CSB204201R4630	800309			0.350	1
	1000	63	DDA204 A S-63/1	2CSB204201R5630	800408			0.350	1

Attention:

All DDA 200 A S are provided with additional terminals for remote tripping

3

3

TECHNICAL CHARACTERISTICS				
Standards				
Electrical features	Operating characteristic: type (wave form of the earth leakage sensed)			
	Poles			
	Rated sensitivity $I\Delta n$		A	
	Rated current I_n		A	
	Rated voltage U_n	1P+N	V	
		2P, 3P, 4P	V	
	Rated residual operating current		A	
	Insulation voltage U_i		V	
	Max. operating voltage of circuit test		V	
	Min. operating voltage of circuit test		V	
	Rated frequency		Hz	
	Rated breaking capacity acc. to IEC/EN 61009	ultimate I_{cn}	A	
	Rated breaking capacity acc. to IEC/EN 60947-2 1P+N @230 VAC, 2P, 3P, 4P @400 VAC	ultimate I_{cu} service I_{cs}	kA kA	
	Rated residual breaking capacity $I\Delta m$		kA	
	Rated impulse withstand voltage (1.2/50) U_{imp}		kV	
	Dielectric test voltage at ind. freq. for 1 min.		kV	
	Overvoltage category			
Thermomagnetic release characteristic	B: $3 I_n \leq I_m \leq 5 I_n$ C: $5 I_n \leq I_m \leq 10 I_n$ K: $8 I_n \leq I_m \leq 14 I_n$			
Surge current resistance (wave 8/20)			A	
Mechanical features	Toggle	1P+N, 2P, 3P, 4P		
	Electrical life			
	Mechanical life			
	Protection degree	housing terminals		
	Tropicalization acc. to IEC /EN 60068-2	humid heat constant climatic conditions variable climatic conditions	°C/RH °C/RH °C/RH	
	Reference temperature for setting of thermal element		°C	
	Ambient temperature (with daily average $\leq +35$ °C)		°C	
	Storage temperature		°C	
Installation	Terminal type	top bottom 1P+N/2P 3P/4P $I_n \leq 40$ A 3P/4P 50 A $\leq I_n \leq 63$ A		
	Terminal size top/bottom per cable	1P+N 2P 3P/4P $I_n \leq 40$ A 3P/4P 50 A $\leq I_n \leq 63$ A	mm ² mm ² mm ² mm ²	
	Tightening torque top/bottom	1P+N 2P 3P/4P $I_n \leq 40$ A 3P/4P 50 A $\leq I_n \leq 63$ A	N*m N*m N*m N*m	
	Mounting			
	Connection			
	Dimensions and weight	Dimensions (H x D x W)	1P+N 2P 3P $I_n \leq 40$ A 4P $I_n \leq 40$ A 3P 50 A $\leq I_n \leq 63$ A 4P 50 A $\leq I_n \leq 63$ A	mm mm mm mm mm mm
		Weight	1P+N 2P 3P $I_n \leq 40$ A 4P $I_n \leq 40$ A 3P 50 A $\leq I_n \leq 63$ A 4P 50 A $\leq I_n \leq 63$ A	g g g g g g
Combination with auxiliary elements		Combinable with:		
		auxiliary contact		
		signal contact/auxiliary switch		
		shunt trip undervoltage release		

① prior to connection of aluminium conductors (≥ 4 mm²) ensure that their contact points are cleaned, brushed and coated with grease



FS 201	DS 200 AC	DS 200 A	DS 200 M AC	DS 200 M A
IEC/EN 61009, IEC/EN 60947-2				
A	AC	A	AC	A
1P+N		2P, 3P, 4P		
0.01-0.03-0.3		0.03		
6, 10, 13, 16, 20, 25, 32, 40		6, 10, 13, 16, 20, 25, 32, 40, 50, 63		
		230-240		
		230/400 - 240/415		
0.01...0.3		0.03		
		500		
		254 (440 for 3P and 4P)		
		110 (195 for 3P and 4P)		
		50...60		
6000	6000	6000	10000	10000
10	10	10	15	15
7.5	7.5	7.5	11.2	11.2
6	6	6	10	10
		2.5		
		III, disconnector abilities		
■ ■ ■		■ ■		
		250		
black sealable in ON-OFF position		black (MCB) sealable in ON-OFF position + blue (RCD)		
		10000		
		20000		
		IP4X		
		IP2X		
		28 cycles with 55/95...100		
		23/83 - 40/93 - 55/20		
		25/95 - 40/95		
		30 (20 for characteristics K)		
-5...+40		-25...+55		
		-40...+70		
		failsafe bidirectional cylinder-lift terminal (shock protected) ①		
		failsafe bidirectional cylinder-lift terminal (shock protected) ①		
		cage (shock protected)		
		failsafe bidirectional cylinder-lift terminal (shock protected) ①		
(rigid and flexible) up to 16/16		-		
		(rigid and flexible) up to 25/25		
		(rigid and flexible) up to 25/16		
		(rigid and flexible) up to 25/25		
2.5/2.5		-		
		2.8/2.8		
		2.8/1.2		
		2.8/2.8		
		on DIN rail EN 60715 (35 mm) by means of fast clip device		
		from top and bottom		
85 x 69 x 35		-		
		85 x 69 x 70		
		85 x 69 x 87.5		
		85 x 69 x 105		
		85 x 69 x 122.5		
		85 x 69 x 140		
200		-		
		475		
		625		
		775		
		775		
		925		
no		yes		
no		yes		
no		yes		
no		yes		

B

FS 201 A type, B, C and K characteristics

Function: protection against overload and short-circuit currents; protection against the effects of sinusoidal alternating and direct pulsating earth fault currents; protection against indirect contacts and additional protection against direct contacts; command and isolation of resistive and inductive loads.

Application: commercial, industrial.

Standard: IEC/EN 61009 and IEC/EN 60947-2

I_{cn}=6 kA

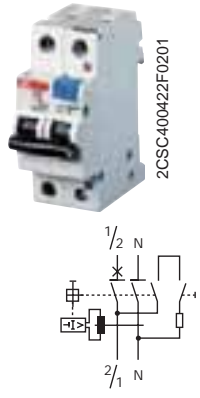

Number of poles	Type/class	Rated residual current I _{Δn} mA	Rated current I _n A	Order details		Bbn 8012542	Price 1 piece	Price group	Weight 1 piece kg	Pack unit pc.
				Type code	Order code					
1P+N	A	10	10	FS 201-B 10/0.01	2CSR255101R0105	982609			0.200	1
			13	FS 201-B 13/0.01	2CSR255101R0135	982708			0.200	1
			16	FS 201-B 16/0.01	2CSR255101R0165	982807			0.200	1
		30	6	FS 201-B 6/0.03	2CSR255101R1065	983408			0.200	1
			10	FS 201-B 10/0.03	2CSR255101R1105	983705			0.200	1
			13	FS 201-B 13/0.03	2CSR255101R1135	984009			0.200	1
			16	FS 201-B 16/0.03	2CSR255101R1165	984306			0.200	1
			20	FS 201-B 20/0.03	2CSR255101R1205	984603			0.200	1
			25	FS 201-B 25/0.03	2CSR255101R1255	984900			0.200	1
			32	FS 201-B 32/0.03	2CSR255101R1325	985204			0.200	1
			40	FS 201-B 40/0.03	2CSR255101R1405	985501			0.200	1

C

1P+N	A	30	6	FS 201-C 6/0.03	2CSR255101R1064	983309			0.200	1
			10	FS 201-C 10/0.03	2CSR255101R1104	983606			0.200	1
			13	FS 201-C 13/0.03	2CSR255101R1134	983903			0.200	1
			16	FS 201-C 16/0.03	2CSR255101R1164	984207			0.200	1
			20	FS 201-C 20/0.03	2CSR255101R1204	984504			0.200	1
			25	FS 201-C 25/0.03	2CSR255101R1254	984801			0.200	1
			32	FS 201-C 32/0.03	2CSR255101R1324	985105			0.200	1
			40	FS 201-C 40/0.03	2CSR255101R1404	985402			0.200	1
			300	6	FS 201-C 6/0.3	2CSR255101R3064	985907			0.200
		10		FS 201-C 10/0.3	2CSR255101R3104	986102			0.200	1
		13		FS 201-C 13/0.3	2CSR255101R3134	986300			0.200	1
		16		FS 201-C 16/0.3	2CSR255101R3164	986508			0.200	1
		20		FS 201-C 20/0.3	2CSR255101R3204	986706			0.200	1
		25		FS 201-C 25/0.3	2CSR255101R3254	986904			0.200	1
		32		FS 201-C 32/0.3	2CSR255101R3324	987109			0.200	1
		40		FS 201-C 40/0.3	2CSR255101R3404	987307			0.200	1

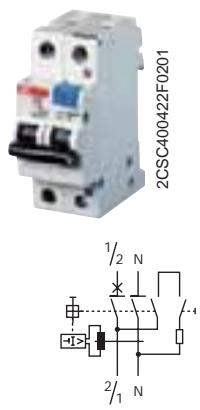

K

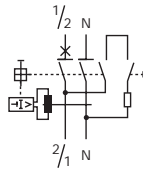

1P+N	A	10	16	FS 201-K 16/0.01	2CSR255101R0167	982906	0.200	1		
30	A	30	1	FS 201-K 1/0.03	2CSR255101R1017	983002	0.200	1		
		2	2	FS 201-K 2/0.03	2CSR255101R1027	983101	0.200	1		
		4	4	FS 201-K 4/0.03	2CSR255101R1047	983200	0.200	1		
		6	6	FS 201-K 6/0.03	2CSR255101R1067	983507	0.200	1		
		10	10	FS 201-K 10/0.03	2CSR255101R1107	983804	0.200	1		
		13	13	FS 201-K 13/0.03	2CSR255101R1137	984108	0.200	1		
		16	16	FS 201-K 16/0.03	2CSR255101R1167	984405	0.200	1		
		20	20	FS 201-K 20/0.03	2CSR255101R1207	984702	0.200	1		
		25	25	FS 201-K 25/0.03	2CSR255101R1257	985006	0.200	1		
		32	32	FS 201-K 32/0.03	2CSR255101R1327	985303	0.200	1		
		300	A	1	1	FS 201-K 1/0.3	2CSR255101R3017	985600	0.200	1
				2	2	FS 201-K 2/0.3	2CSR255101R3027	985709	0.200	1
4	4			FS 201-K 4/0.3	2CSR255101R3047	985808	0.200	1		
6	6			FS 201-K 6/0.3	2CSR255101R3067	986003	0.200	1		
10	10			FS 201-K 10/0.3	2CSR255101R3107	986201	0.200	1		
13	13			FS 201-K 13/0.3	2CSR255101R3137	986409	0.200	1		
16	16			FS 201-K 16/0.3	2CSR255101R3167	986607	0.200	1		
20	20			FS 201-K 20/0.3	2CSR255101R3207	986805	0.200	1		
25	25			FS 201-K 25/0.3	2CSR255101R3257	987000	0.200	1		
32	32			FS 201-K 32/0.3	2CSR255101R3327	987208	0.200	1		

3

B

DS 200 AC type, B characteristic

Function: protection against overload and short-circuit currents; protection against the effects of sinusoidal alternating earth fault currents; protection against indirect contacts and additional protection against direct contacts; command and isolation of resistive and inductive loads.

Application: commercial, industrial.

Standard: IEC/EN 61009 and IEC/EN 60947-2

Icn=6 kA

3

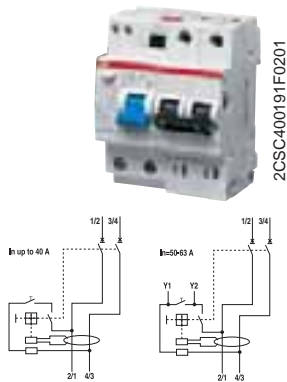

2CSC400191F0201

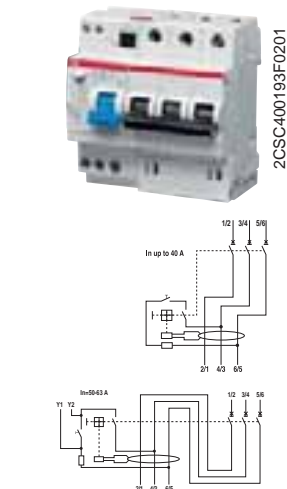

2CSC400193F0201

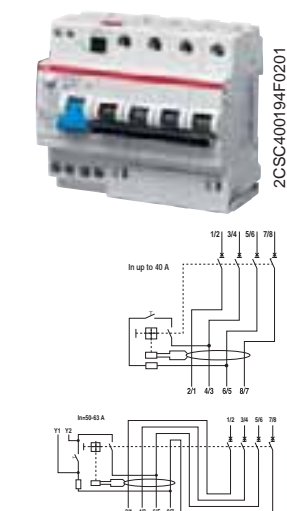

2CSC400194F0201

Number of poles	Type/class	Rated residual current IΔn mA	Rated current In A	Order details		Bbn 8012542	Price 1 piece	Price group	Weight 1 piece	Pack unit
				Type code	Order code					
2	AC	30	6	DS202 AC-B6/0.03	2CSR252001R1065	863502			0.475	1
				DS202 AC-B10/0.03	2CSR252001R1105	863601			0.475	1
				DS202 AC-B13/0.03	2CSR252001R1135	863700			0.475	1
				DS202 AC-B16/0.03	2CSR252001R1165	863809			0.475	1
				DS202 AC-B20/0.03	2CSR252001R1205	863908			0.475	1
				DS202 AC-B25/0.03	2CSR252001R1255	864004			0.475	1
				DS202 AC-B32/0.03	2CSR252001R1325	864103			0.475	1
				DS202 AC-B40/0.03	2CSR252001R1405	864202			0.475	1
				DS202 AC-B50/0.03	2CSR252001R1505	864301			0.475	1
				DS202 AC-B63/0.03	2CSR252001R1635	864400			0.475	1

3	AC	30	6	DS203 AC-B6/0.03	2CSR253001R1065	865506			0.625	1
				DS203 AC-B10/0.03	2CSR253001R1105	865605			0.625	1
				DS203 AC-B13/0.03	2CSR253001R1135	865704			0.625	1
				DS203 AC-B16/0.03	2CSR253001R1165	865803			0.625	1
				DS203 AC-B20/0.03	2CSR253001R1205	865902			0.625	1
				DS203 AC-B25/0.03	2CSR253001R1255	866008			0.625	1
				DS203 AC-B32/0.03	2CSR253001R1325	866107			0.625	1
				DS203 AC-B40/0.03	2CSR253001R1405	866206			0.625	1
				DS203 AC-B50/0.03	2CSR253001R1505	866305			0.775	1
				DS203 AC-B63/0.03	2CSR253001R1635	866404			0.775	1

4	AC	30	6	DS204 AC-B6/0.03	2CSR254001R1065	867500			0.775	1
				DS204 AC-B10/0.03	2CSR254001R1105	867609			0.775	1
				DS204 AC-B13/0.03	2CSR254001R1135	867708			0.775	1
				DS204 AC-B16/0.03	2CSR254001R1165	867807			0.775	1
				DS204 AC-B20/0.03	2CSR254001R1205	867906			0.775	1
				DS204 AC-B25/0.03	2CSR254001R1255	868002			0.775	1
				DS204 AC-B32/0.03	2CSR254001R1325	868101			0.775	1
				DS204 AC-B40/0.03	2CSR254001R1405	868200			0.775	1
				DS204 AC-B50/0.03	2CSR254001R1505	868309			0.925	1
				DS204 AC-B63/0.03	2CSR254001R1635	868408			0.925	1

① provided with additional terminals for remote tripping

C

DS 200 AC type, C characteristic

Function: protection against overload and short-circuit currents; protection against the effects of sinusoidal alternating earth fault currents; protection against indirect contacts and additional protection against direct contacts; command and isolation of resistive and inductive loads.

Application: commercial, industrial.

Standard: IEC/EN 61009 and IEC/EN 60947-2

Icn=6 kA

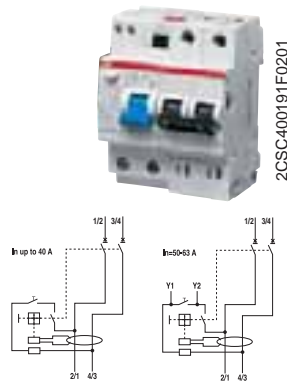

2CSC400191F0201

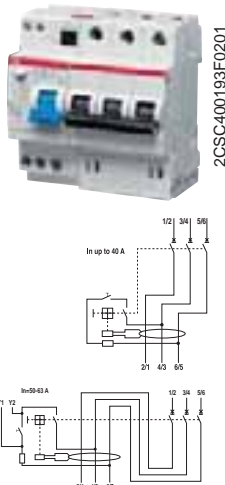

2CSC400193F0201

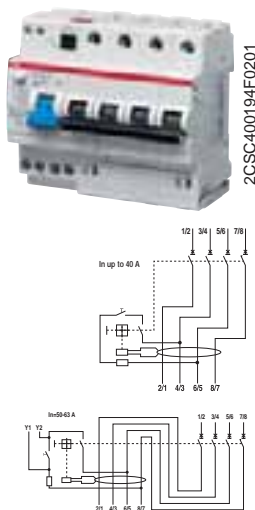

2CSC400194F0201

Number of poles	Type/class	Rated residual current IΔn mA	Rated current In A	Order details		Bbn 8012542	Price 1 piece	Price group	Weight 1 piece kg	Pack unit pc.
				Type code	Order code					
2	AC	30	6	DS202 AC-C6/0.03	2CSR252001R1064	869504			0.475	1
			10	DS202 AC-C10/0.03	2CSR252001R1104	869603			0.475	1
			13	DS202 AC-C13/0.03	2CSR252001R1134	869702			0.475	1
			16	DS202 AC-C16/0.03	2CSR252001R1164	869801			0.475	1
			20	DS202 AC-C20/0.03	2CSR252001R1204	869900			0.475	1
			25	DS202 AC-C25/0.03	2CSR252001R1254	870005			0.475	1
			32	DS202 AC-C32/0.03	2CSR252001R1324	870104			0.475	1
			40	DS202 AC-C40/0.03	2CSR252001R1404	870203			0.475	1
			50 ①	DS202 AC-C50/0.03	2CSR252001R1504	870302			0.475	1
			63 ①	DS202 AC-C63/0.03	2CSR252001R1634	870401			0.475	1

3	AC	30	6	DS203 AC-C6/0.03	2CSR253001R1064	871507			0.625	1
			10	DS203 AC-C10/0.03	2CSR253001R1104	871606			0.625	1
			13	DS203 AC-C13/0.03	2CSR253001R1134	871705			0.625	1
			16	DS203 AC-C16/0.03	2CSR253001R1164	871804			0.625	1
			20	DS203 AC-C20/0.03	2CSR253001R1204	871903			0.625	1
			25	DS203 AC-C25/0.03	2CSR253001R1254	872009			0.625	1
			32	DS203 AC-C32/0.03	2CSR253001R1324	872108			0.625	1
			40	DS203 AC-C40/0.03	2CSR253001R1404	872207			0.625	1
			50 ①	DS203 AC-C50/0.03	2CSR253001R1504	872306			0.775	1
			63 ①	DS203 AC-C63/0.03	2CSR253001R1634	872405			0.775	1

4	AC	30	6	DS204 AC-C6/0.03	2CSR254001R1064	873501			0.775	1
			10	DS204 AC-C10/0.03	2CSR254001R1104	873600			0.775	1
			13	DS204 AC-C13/0.03	2CSR254001R1134	873709			0.775	1
			16	DS204 AC-C16/0.03	2CSR254001R1164	873808			0.775	1
			20	DS204 AC-C20/0.03	2CSR254001R1204	873907			0.775	1
			25	DS204 AC-C25/0.03	2CSR254001R1254	874003			0.775	1
			32	DS204 AC-C32/0.03	2CSR254001R1324	874102			0.775	1
			40	DS204 AC-C40/0.03	2CSR254001R1404	874201			0.775	1
			50 ①	DS204 AC-C50/0.03	2CSR254001R1504	874300			0.925	1
			63 ①	DS204 AC-C63/0.03	2CSR254001R1634	874409			0.925	1

① provided with additional terminals for remote tripping

B

DS 200 A type, B characteristic

Function: protection against overload and short-circuit currents; protection against the effects of sinusoidal alternating and direct pulsating earth fault currents; protection against indirect contacts and additional protection against direct contacts; command and isolation of resistive and inductive loads.

Application: commercial, industrial.

Standard: IEC/EN 61009 and IEC/EN 60947-2

Icn=6 kA

3



2CSC400191F0201

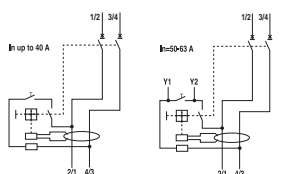

2CSC400193F0201

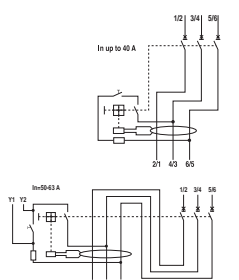

2CSC400194F0201

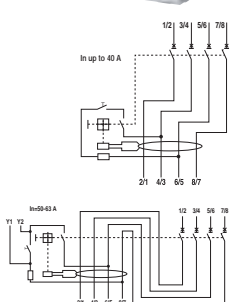

Number of poles	Type/class	Rated residual current IΔn mA	Rated current In A	Order details		Bbn 8012542	Price 1 piece	Price group	Weight 1 piece	Pack unit
				Type code	Order code					
2	A	30	6	DS202 A-B6/0.03	2CSR252101R1065	857501			0.475	1
				DS202 A-B10/0.03	2CSR252101R1105	857600		0.475	1	
				DS202 A-B13/0.03	2CSR252101R1135	857709		0.475	1	
				DS202 A-B16/0.03	2CSR252101R1165	857808		0.475	1	
				DS202 A-B20/0.03	2CSR252101R1205	857907		0.475	1	
				DS202 A-B25/0.03	2CSR252101R1255	858003		0.475	1	
				DS202 A-B32/0.03	2CSR252101R1325	858102		0.475	1	
				DS202 A-B40/0.03	2CSR252101R1405	858201		0.475	1	
				DS202 A-B50/0.03	2CSR252101R1505	858300		0.475	1	
				DS202 A-B63/0.03	2CSR252101R1635	858409		0.475	1	

3	A	30	6	DS203 A-B6/0.03	2CSR253101R1065	858508			0.625	1
				DS203 A-B10/0.03	2CSR253101R1105	858607		0.625	1	
				DS203 A-B13/0.03	2CSR253101R1135	858706		0.625	1	
				DS203 A-B16/0.03	2CSR253101R1165	858805		0.625	1	
				DS203 A-B20/0.03	2CSR253101R1205	858904		0.625	1	
				DS203 A-B25/0.03	2CSR253101R1255	859000		0.625	1	
				DS203 A-B32/0.03	2CSR253101R1325	859109		0.625	1	
				DS203 A-B40/0.03	2CSR253101R1405	859208		0.625	1	
				DS203 A-B50/0.03	2CSR253101R1505	859307		0.775	1	
				DS203 A-B63/0.03	2CSR253101R1635	859406		0.775	1	

4	A	30	6	DS204 A-B6/0.03	2CSR254101R1065	859505			0.775	1
				DS204 A-B10/0.03	2CSR254101R1105	859604		0.775	1	
				DS204 A-B13/0.03	2CSR254101R1135	859703		0.775	1	
				DS204 A-B16/0.03	2CSR254101R1165	859802		0.775	1	
				DS204 A-B20/0.03	2CSR254101R1205	859901		0.775	1	
				DS204 A-B25/0.03	2CSR254101R1255	860006		0.775	1	
				DS204 A-B32/0.03	2CSR254101R1325	860105		0.775	1	
				DS204 A-B40/0.03	2CSR254101R1405	860204		0.775	1	
				DS204 A-B50/0.03	2CSR254101R1505	860303		0.925	1	
				DS204 A-B63/0.03	2CSR254101R1635	860402		0.925	1	

① provided with additional terminals for remote tripping

C

DS 200 A type, C characteristic

Function: protection against overload and short-circuit currents; protection against the effects of sinusoidal alternating and direct pulsating earth fault currents; protection against indirect contacts and additional protection against direct contacts; command and isolation of resistive and inductive loads.

Application: commercial, industrial.

Standard: IEC/EN 61009 and IEC/EN 60947-2

Icn=6 kA

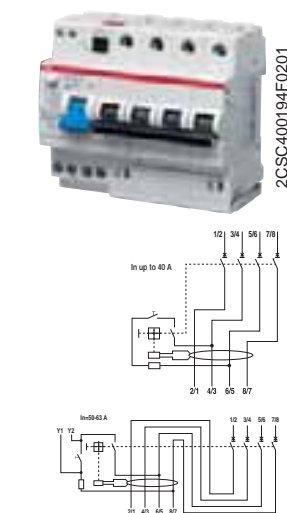
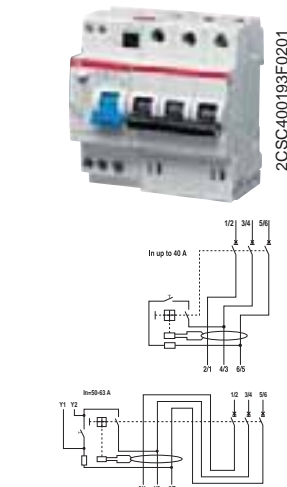
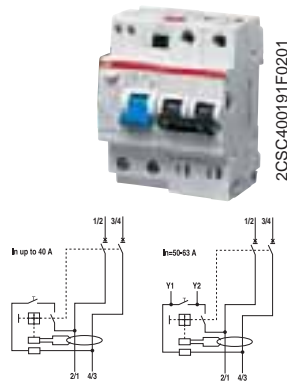

Number of poles	Type/class	Rated residual current IΔn mA	Rated current In A	Order details		Bbn 8012542	Price 1 piece	Price group	Weight 1 piece kg	Pack unit pc.
				Type code	Order code					
2	A	30	6	DS202 A-C6/0.03	2CSR252101R1064	860501			0.475	1
			10	DS202 A-C10/0.03	2CSR252101R1104	860600			0.475	1
			13	DS202 A-C13/0.03	2CSR252101R1134	860709			0.475	1
			16	DS202 A-C16/0.03	2CSR252101R1164	860808			0.475	1
			20	DS202 A-C20/0.03	2CSR252101R1204	860907			0.475	1
			25	DS202 A-C25/0.03	2CSR252101R1254	861003			0.475	1
			32	DS202 A-C32/0.03	2CSR252101R1324	861102			0.475	1
			40	DS202 A-C40/0.03	2CSR252101R1404	861201			0.475	1
			50 ①	DS202 A-C50/0.03	2CSR252101R1504	861300			0.475	1
			63 ①	DS202 A-C63/0.03	2CSR252101R1634	861409			0.475	1
3	A	30	6	DS203 A-C6/0.03	2CSR253101R1064	861508			0.625	1
			10	DS203 A-C10/0.03	2CSR253101R1104	861607			0.625	1
			13	DS203 A-C13/0.03	2CSR253101R1134	861706			0.625	1
			16	DS203 A-C16/0.03	2CSR253101R1164	861805			0.625	1
			20	DS203 A-C20/0.03	2CSR253101R1204	861904			0.625	1
			25	DS203 A-C25/0.03	2CSR253101R1254	862000			0.625	1
			32	DS203 A-C32/0.03	2CSR253101R1324	862109			0.625	1
			40	DS203 A-C40/0.03	2CSR253101R1404	862208			0.625	1
			50 ①	DS203 A-C50/0.03	2CSR253101R1504	862307			0.775	1
			63 ①	DS203 A-C63/0.03	2CSR253101R1634	862406			0.775	1
4	A	30	6	DS204 A-C6/0.03	2CSR254101R1064	862505			0.775	1
			10	DS204 A-C10/0.03	2CSR254101R1104	862604			0.775	1
			13	DS204 A-C13/0.03	2CSR254101R1134	862703			0.775	1
			16	DS204 A-C16/0.03	2CSR254101R1164	862802			0.775	1
			20	DS204 A-C20/0.03	2CSR254101R1204	862901			0.775	1
			25	DS204 A-C25/0.03	2CSR254101R1254	863007			0.775	1
			32	DS204 A-C32/0.03	2CSR254101R1324	863106			0.775	1
			40	DS204 A-C40/0.03	2CSR254101R1404	863205			0.775	1
			50 ①	DS204 A-C50/0.03	2CSR254101R1504	863304			0.925	1
			63 ①	DS204 A-C63/0.03	2CSR254101R1634	863403			0.925	1

① provided with additional terminals for remote tripping

B

DS 200 M AC type, B characteristic

Function: protection against overload and short-circuit currents; protection against the effects of sinusoidal alternating earth fault currents; protection against indirect contacts and additional protection against direct contacts; command and isolation of resistive and inductive loads.

Application: commercial, industrial.

Standard: IEC/EN 61009 and IEC/EN 60947-2

I_{cn}=10 kA

3

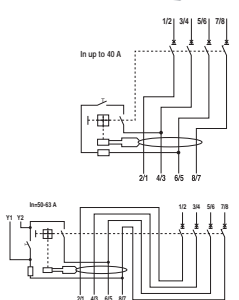
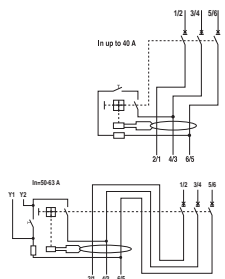
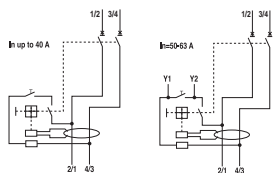

Number of poles	Type/class	Rated residual current I Δ n mA	Rated current In A	Order details		Bbn 8012542	Price 1 piece	Price group	Weight 1 piece kg	Pack unit pc.
				Type code	Order code					
2	AC	30	6	DS202 M AC-B6/0.03	2CSR272001R1065	851509			0.475	1
				DS202 M AC-B10/0.03	2CSR272001R1105	851608		0.475	1	
				DS202 M AC-B13/0.03	2CSR272001R1135	851707		0.475	1	
				DS202 M AC-B16/0.03	2CSR272001R1165	851806		0.475	1	
				DS202 M AC-B20/0.03	2CSR272001R1205	851905		0.475	1	
				DS202 M AC-B25/0.03	2CSR272001R1255	852001		0.475	1	
				DS202 M AC-B32/0.03	2CSR272001R1325	852100		0.475	1	
				DS202 M AC-B40/0.03	2CSR272001R1405	852209		0.475	1	
				DS202 M AC-B50/0.03	2CSR272001R1505	852308		0.475	1	
				DS202 M AC-B63/0.03	2CSR272001R1635	852407		0.475	1	

3	AC	30	6	DS203 M AC-B6/0.03	2CSR273001R1065	852506			0.625	1
				DS203 M AC-B10/0.03	2CSR273001R1105	852605		0.625	1	
				DS203 M AC-B13/0.03	2CSR273001R1135	852704		0.625	1	
				DS203 M AC-B16/0.03	2CSR273001R1165	852803		0.625	1	
				DS203 M AC-B20/0.03	2CSR273001R1205	852902		0.625	1	
				DS203 M AC-B25/0.03	2CSR273001R1255	853008		0.625	1	
				DS203 M AC-B32/0.03	2CSR273001R1325	853107		0.625	1	
				DS203 M AC-B40/0.03	2CSR273001R1405	853206		0.625	1	
				DS203 M AC-B50/0.03	2CSR273001R1505	853305		0.775	1	
				DS203 M AC-B63/0.03	2CSR273001R1635	853404		0.775	1	

4	AC	30	6	DS204 M AC-B6/0.03	2CSR274001R1065	853503			0.775	1
				DS204 M AC-B10/0.03	2CSR274001R1105	853602		0.775	1	
				DS204 M AC-B13/0.03	2CSR274001R1135	853701		0.775	1	
				DS204 M AC-B16/0.03	2CSR274001R1165	853800		0.775	1	
				DS204 M AC-B20/0.03	2CSR274001R1205	853909		0.775	1	
				DS204 M AC-B25/0.03	2CSR274001R1255	854005		0.775	1	
				DS204 M AC-B32/0.03	2CSR274001R1325	854104		0.775	1	
				DS204 M AC-B40/0.03	2CSR274001R1405	854203		0.775	1	
				DS204 M AC-B50/0.03	2CSR274001R1505	854302		0.925	1	
				DS204 M AC-B63/0.03	2CSR274001R1635	854401		0.925	1	

① provided with additional terminals for remote tripping

C

DS 200 M AC type, C characteristic

Function: protection against overload and short-circuit currents; protection against the effects of sinusoidal alternating earth fault currents; protection against indirect contacts and additional protection against direct contacts; command and isolation of resistive and inductive loads.

Application: commercial, industrial.

Standard: IEC/EN 61009 and IEC/EN 60947-2

Icn=10 kA

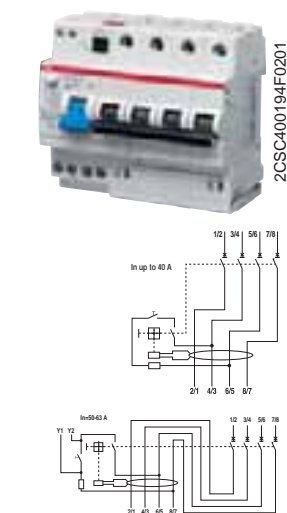
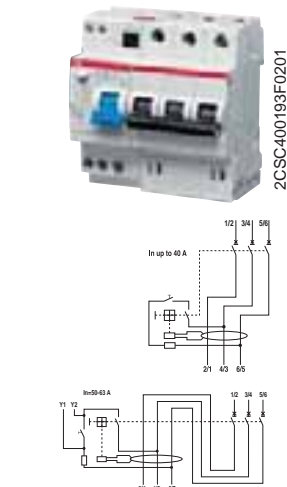
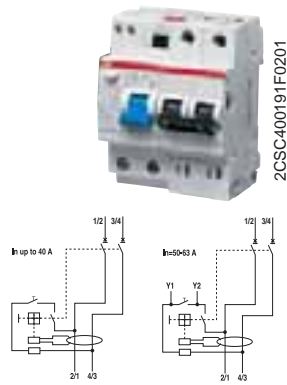

Number of poles	Type/class	Rated residual current IΔn mA	Rated current In A	Order details Type code	Order code	Bbn 8012542	Price 1 piece	Price group	Weight 1 piece kg	Pack unit pc.
2	AC	30	6	DS202 M AC-C6/0.03	2CSR272001R1064	851509			0.475	1
			10	DS202 M AC-C10/0.03	2CSR272001R1104	851608			0.475	1
			13	DS202 M AC-C13/0.03	2CSR272001R1134	851707			0.475	1
			16	DS202 M AC-C16/0.03	2CSR272001R1164	851806			0.475	1
			20	DS202 M AC-C20/0.03	2CSR272001R1204	851905			0.475	1
			25	DS202 M AC-C25/0.03	2CSR272001R1254	852001			0.475	1
			32	DS202 M AC-C32/0.03	2CSR272001R1324	852100			0.475	1
			40	DS202 M AC-C40/0.03	2CSR272001R1404	852209			0.475	1
			50 ①	DS202 M AC-C50/0.03	2CSR272001R1504	852308			0.475	1
63 ①	DS202 M AC-C63/0.03	2CSR272001R1634	852407			0.475	1			

3	AC	30	6	DS203 M AC-C6/0.03	2CSR273001R1064	852506			0.625	1
			10	DS203 M AC-C10/0.03	2CSR273001R1104	852605			0.625	1
			13	DS203 M AC-C13/0.03	2CSR273001R1134	852704			0.625	1
			16	DS203 M AC-C16/0.03	2CSR273001R1164	852803			0.625	1
			20	DS203 M AC-C20/0.03	2CSR273001R1204	852902			0.625	1
			25	DS203 M AC-C25/0.03	2CSR273001R1254	853008			0.625	1
			32	DS203 M AC-C32/0.03	2CSR273001R1324	853107			0.625	1
			40	DS203 M AC-C40/0.03	2CSR273001R1404	853206			0.625	1
			50 ①	DS203 M AC-C50/0.03	2CSR273001R1504	853305			0.775	1
63 ①	DS203 M AC-C63/0.03	2CSR273001R1634	853404			0.775	1			

4	AC	30	6	DS204 M AC-C6/0.03	2CSR274001R1064	853503			0.775	1
			10	DS204 M AC-C10/0.03	2CSR274001R1104	853602			0.775	1
			13	DS204 M AC-C13/0.03	2CSR274001R1134	853701			0.775	1
			16	DS204 M AC-C16/0.03	2CSR274001R1164	853800			0.775	1
			20	DS204 M AC-C20/0.03	2CSR274001R1204	853909			0.775	1
			25	DS204 M AC-C25/0.03	2CSR274001R1254	854005			0.775	1
			32	DS204 M AC-C32/0.03	2CSR274001R1324	854104			0.775	1
			40	DS204 M AC-C40/0.03	2CSR274001R1404	854203			0.775	1
			50 ①	DS204 M AC-C50/0.03	2CSR274001R1504	854302			0.925	1
63 ①	DS204 M AC-C63/0.03	2CSR274001R1634	854401			0.925	1			

① provided with additional terminals for remote tripping

B

DS 200 M A type, B characteristic

Function: protection against overload and short-circuit currents; protection against the effects of sinusoidal alternating and direct pulsating earth fault currents; protection against indirect contacts and additional protection against direct contacts; command and isolation of resistive and inductive loads.

Application: commercial, industrial.

Standard: IEC/EN 61009 and IEC/EN 60947-2

Icn=10 kA

3



2CSC400191F0201

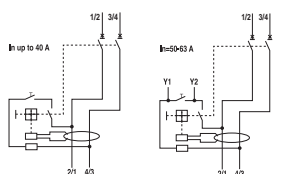

2CSC400193F0201

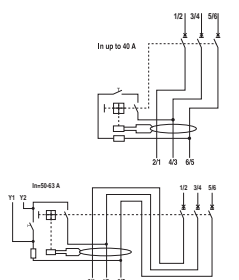

2CSC400194F0201

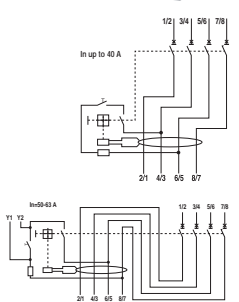

Number of poles	Type/class	Rated residual current IΔn mA	Rated current In A	Order details		Bbn 8012542	Price 1 piece	Price group	Weight 1 piece kg	Pack unit pc.
				Type code	Order code					
2	A	30	6	DS202 M A-B6/0.03	2CSR272101R1065	845508			0.475	1
				DS202 M A-B10/0.03	2CSR272101R1105	845607		0.475	1	
				DS202 M A-B13/0.03	2CSR272101R1135	845706		0.475	1	
				DS202 M A-B16/0.03	2CSR272101R1165	845805		0.475	1	
				DS202 M A-B20/0.03	2CSR272101R1205	845904		0.475	1	
				DS202 M A-B25/0.03	2CSR272101R1255	846000		0.475	1	
				DS202 M A-B32/0.03	2CSR272101R1325	846109		0.475	1	
				DS202 M A-B40/0.03	2CSR272101R1405	846208		0.475	1	
				DS202 M A-B50/0.03	2CSR272101R1505	846307		0.475	1	
				DS202 M A-B63/0.03	2CSR272101R1635	846406		0.475	1	

3	A	30	6	DS203 M A-B6/0.03	2CSR273101R1065	846505			0.625	1
				DS203 M A-B10/0.03	2CSR273101R1105	846604		0.625	1	
				DS203 M A-B13/0.03	2CSR273101R1135	846703		0.625	1	
				DS203 M A-B16/0.03	2CSR273101R1165	846802		0.625	1	
				DS203 M A-B20/0.03	2CSR273101R1205	846901		0.625	1	
				DS203 M A-B25/0.03	2CSR273101R1255	847007		0.625	1	
				DS203 M A-B32/0.03	2CSR273101R1325	847106		0.625	1	
				DS203 M A-B40/0.03	2CSR273101R1405	847205		0.625	1	
				DS203 M A-B50/0.03	2CSR273101R1505	847304		0.775	1	
				DS203 M A-B63/0.03	2CSR273101R1635	847403		0.775	1	

4	A	30	6	DS204 M A-B6/0.03	2CSR274101R1065	847502			0.775	1
				DS204 M A-B10/0.03	2CSR274101R1105	847601		0.775	1	
				DS204 M A-B13/0.03	2CSR274101R1135	847700		0.775	1	
				DS204 M A-B16/0.03	2CSR274101R1165	847809		0.775	1	
				DS204 M A-B20/0.03	2CSR274101R1205	847908		0.775	1	
				DS204 M A-B25/0.03	2CSR274101R1255	848004		0.775	1	
				DS204 M A-B32/0.03	2CSR274101R1325	848103		0.775	1	
				DS204 M A-B40/0.03	2CSR274101R1405	848202		0.775	1	
				DS204 M A-B50/0.03	2CSR274101R1505	848301		0.925	1	
				DS204 M A-B63/0.03	2CSR274101R1635	848400		0.925	1	

① provided with additional terminals for remote tripping

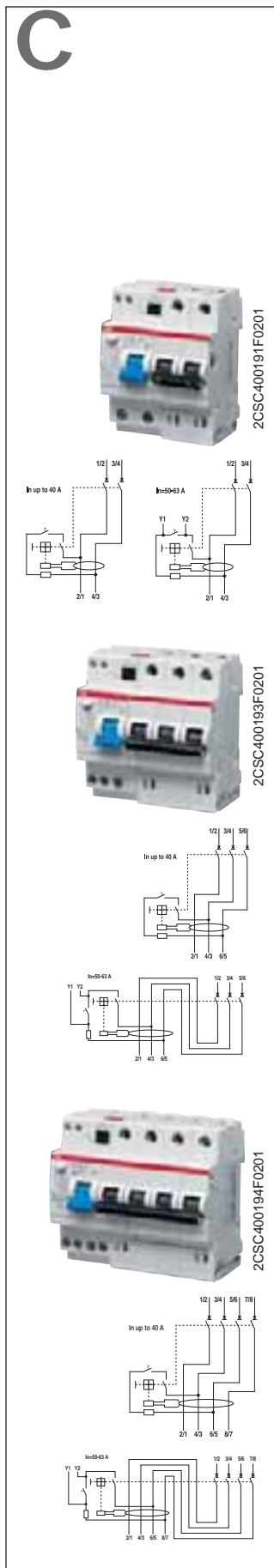

DS 200 M A type, C characteristic

Function: protection against overload and short-circuit currents; protection against the effects of sinusoidal alternating and direct pulsating earth fault currents; protection against indirect contacts and additional protection against direct contacts; command and isolation of resistive and inductive loads.

Application: commercial, industrial.

Standard: IEC/EN 61009 and IEC/EN 60947-2

Icn=10 kA

Number of poles	Type/class	Rated residual current IΔn mA	Rated current In A	Order details		Bbn 8012542	Price 1 piece	Price group	Weight 1 piece kg	Pack unit pc.
				Type code	Order code					
2	A	30	6	DS202 M A-C6/0.03	2CSR272101R1064	848509			0.475	1
			10	DS202 M A-C10/0.03	2CSR272101R1104	848608			0.475	1
			13	DS202 M A-C13/0.03	2CSR272101R1134	848707			0.475	1
			16	DS202 M A-C16/0.03	2CSR272101R1164	848806			0.475	1
			20	DS202 M A-C20/0.03	2CSR272101R1204	848905			0.475	1
			25	DS202 M A-C25/0.03	2CSR272101R1254	849001			0.475	1
			32	DS202 M A-C32/0.03	2CSR272101R1324	849100			0.475	1
			40	DS202 M A-C40/0.03	2CSR272101R1404	849209			0.475	1
			50 ①	DS202 M A-C50/0.03	2CSR272101R1504	849308			0.475	1
			63 ①	DS202 M A-C63/0.03	2CSR272101R1634	849407			0.475	1
3	A	30	6	DS203 M A-C6/0.03	2CSR273101R1064	849506			0.625	1
			10	DS203 M A-C10/0.03	2CSR273101R1104	849605			0.625	1
			13	DS203 M A-C13/0.03	2CSR273101R1134	849704			0.625	1
			16	DS203 M A-C16/0.03	2CSR273101R1164	849803			0.625	1
			20	DS203 M A-C20/0.03	2CSR273101R1204	849902			0.625	1
			25	DS203 M A-C25/0.03	2CSR273101R1254	850007			0.625	1
			32	DS203 M A-C32/0.03	2CSR273101R1324	850106			0.625	1
			40	DS203 M A-C40/0.03	2CSR273101R1404	850205			0.625	1
			50 ①	DS203 M A-C50/0.03	2CSR273101R1504	850304			0.775	1
			63 ①	DS203 M A-C63/0.03	2CSR273101R1634	850403			0.775	1
4	A	30	6	DS204 M A-C6/0.03	2CSR274101R1064	850502			0.775	1
			10	DS204 M A-C10/0.03	2CSR274101R1104	850601			0.775	1
			13	DS204 M A-C13/0.03	2CSR274101R1134	850700			0.775	1
			16	DS204 M A-C16/0.03	2CSR274101R1164	850809			0.775	1
			20	DS204 M A-C20/0.03	2CSR274101R1204	850908			0.775	1
			25	DS204 M A-C25/0.03	2CSR274101R1254	851004			0.775	1
			32	DS204 M A-C32/0.03	2CSR274101R1324	851103			0.775	1
			40	DS204 M A-C40/0.03	2CSR274101R1404	851202			0.775	1
			50 ①	DS204 M A-C50/0.03	2CSR274101R1504	851301			0.925	1
			63 ①	DS204 M A-C63/0.03	2CSR274101R1634	851400			0.925	1

① provided with additional terminals for remote tripping



2CSC400266F0201



2CSC400267F0201



2CSC400572F0201

With the range of RCBOs DS 9.. 1P+N ABB is able to provide a protection solution for all type of single-phase circuits in modern applications.

All the RCBOs are characterized by an innovative design with a single red/green two-color operating lever and residual current trip signal on the front of the apparatus.

The DS 9.. range satisfies all protection requirements in two modules, offering the opportunity of choosing between three

different breaking capacities, five different sensitivities, and for each of these, the possibility of choosing between type A or type AC residual current protection.

The DS 9.. range consists of three series, DS 941, DS 951 and DS 971, with 4.5 kA, 6 kA and 10 kA respectively of breaking capacity.

Overload and short-circuit protection is provided by the same thermomagnetic component as the S 9.. MCBs range.

All RCBOs are insensitive to temporary surge currents generated by lightning, operations on the power network, interferences, etc.

It can be fitted with the same accessories of the S 9.. range, therefore permitting many different functions and configurations.

RCBO DS 271 is a particular combination of MCB+RCCB in a compact housing of only 1 module. It protects both people and lines and equipments.



Index

Technical features of RCBOs DS 9.. series	3/40
Selection tables of RCBOs DS 9.. series	
DS 941 AC B	3/42
DS 941 AC C	3/42
DS 941 A B	3/43
DS 941 A C	3/43
DS 951 AC B	3/44
DS 951 AC C	3/45
DS 951 A B	3/46
DS 951 AP-R A C	3/46
DS 951 A C	3/47
DS 951 A K	3/47
DS 971 AC B	3/48
DS 971 AC C	3/49
DS 971 A B	3/50
DS 971 A C	3/51
Technical features of RCBOs DS 271 series	3/52
Selection tables of RCBOs DS 271 series	
DS 271 AC B	3/54
DS 271 AC C	3/54
DS 271 A B	3/55
DS 271 A C	3/55



3

TECHNICAL CHARACTERISTICS

	Standards		
Electrical features	Type (wave form of the earth leakage sensed)		
	Poles		
	Rated current I_n		A
	Rated sensitivity $I_{\Delta n}$		A
	Rated voltage U_e		V
	Insulation voltage U_i		V
	Max. operating voltage of circuit test		V
	Min. operating voltage of circuit test		V
	Rated frequency		Hz
	Rated breaking capacity acc. to IEC/EN 61009	ultimate I_{cn}	A
	Rated breaking capacity acc. to IEC/EN 60947-2 1P+N @230 VAC, 2P, 3P, 4P @400 VAC	ultimate I_{cu} service I_{cs}	kA kA
	Rated impulse withstand voltage (1.2/50) U_{imp}		kV
	Dielectric test voltage at ind. freq. for 1 min.		kV
	Thermomagnetic release characteristic	B: $3 I_n \leq I_m \leq 5 I_n$ C: $5 I_n \leq I_m \leq 10 I_n$ K: $8 I_n \leq I_m \leq 14 I_n$	
	Surge current resistance (wave 8/20)		A
Mechanical features	Toggle		
	Electrical life		
	Mechanical life		
	Protection degree	housing terminals	
	Tropicalization acc. to IEC /EN 60068-2	humid heat constant climatic conditions variable climatic conditions	°C/RH °C/RH °C/RH
	Reference temperature for setting of thermal element		°C
	Ambient temperature (with daily average $\leq +35$ °C)		°C
	Storage temperature		°C
Installation	Terminal type	top bottom	
	Terminal size top/bottom for cables		mm ²
	Tightening torque top/bottom		N*m
	Mounting Connection		
Dimensions and weight	Dimensions (H x D x W)	1P+N	mm
	Weight	1P+N	g
Combination with auxiliary elements	Combinable with:	auxiliary contact signal contact shunt trip undervoltage release	



DS 941 AC	DS 941 A	DS 951 AC	DS 951 A	DS 951 A AP-R	DS 971 AC	DS 971 A
IEC / EN 61009, IEC / EN 60947-2						
AC	A	AC	A	A	AC	A
6 ≤ In ≤ 40			6 ≤ In ≤ 32			
0.03-0.1-0.3-0.5-1	0.03-0.1-0.3-0.5	0.03-0.1-0.3-0.5-1	0.01-0.03-0.1-0.3-0.5	0.03	0.03-0.1-0.3-0.5-1	0.03-0.1-0.3-0.5
			230-240			
			500			
			254			
			110			
			50...60			
4500			6000			10000
6			10			10
4,5			6			7.5
			5			
			2.5			
		■			■	
		■			■	
		250			3000	250
black sealable in ON-OFF position						
10000						
20000						
IP4X						
IP2X						
28 cycles with 55/95...100						
23/83 - 40/93 - 55/20						
25/95 - 40/95						
30						
-25...+55						
-40...+70						
cage (shock protected)						
cage (shock protected)						
(rigid and flexible) up to 16/16						
1.2						
on DIN rail EN 60715 (35mm) by means of fast clip device						
from top and bottom						
85 x 70 x 35.6						
200						
yes						
yes						
yes						
yes						

3

B



2CSC400326F0201

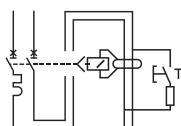

DS 941 AC type, B characteristic

Function: protection in terminal single-phase circuit against overload and short-circuit currents; protection against the effects of sinusoidal alternating earth fault currents; protection against indirect contacts and additional protection against direct contacts ($I_{\Delta n}=30$ mA); command and isolation of resistive and inductive loads, especially in presence of big length cables (typical of single-phase terminal circuits).

Application: residential, commercial, industrial.

Standard: IEC/EN 61009

$I_{cn}=4.5$ kA

Number of poles	Rated residual current $I_{\Delta n}$ mA	Rated current I_n A	Order details		Bbn 8012542	Price 1 piece	Price group	Weight 1 piece kg	Pack unit pc.
			Type code	Order code					
1+N	30	6	DS 941 AC-B6/0.03	16020007	403005		0,200	5	
		10	DS 941 AC-B10/0.03	16020015	403104		0,200	5	
		16	DS 941 AC-B16/0.03	16020023	403203		0,200	5	
		20	DS 941 AC-B20/0.03	16020031	403302		0,200	5	
		25	DS 941 AC-B25/0.03	16020049	403401		0,200	5	
		32	DS 941 AC-B32/0.03	16020056	403500		0,200	5	
		40	DS 941 AC-B40/0.03	16020064	403609		0,200	5	

C



2CSC400326F0201

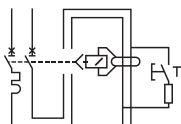

DS 941 AC type, C characteristic

Function: protection in terminal single-phase circuit against overload and short-circuit currents; protection against the effects of sinusoidal alternating earth fault currents; protection against indirect contacts and additional protection against direct contacts ($I_{\Delta n}=30$ mA); command and isolation of resistive and inductive loads.

Application: residential, commercial, industrial.

Standard: IEC/EN 61009

$I_{cn}=4.5$ kA

Number of poles	Rated residual current $I_{\Delta n}$ mA	Rated current I_n A	Order details		Bbn 8012542	Price 1 piece	Price group	Weight 1 piece kg	Pack unit pc.	
			Type code	Order code						EAN
1+N	30	6	DS 941 AC-C6/0.03	16020395	406501		0,200	5		
		10	DS 941 AC-C10/0.03	16020403	406600		0,200	5		
		16	DS 941 AC-C16/0.03	16020411	406709		0,200	5		
		20	DS 941 AC-C20/0.03	16020429	406808		0,200	5		
		25	DS 941 AC-C25/0.03	16020437	406907		0,200	5		
		32	DS 941 AC-C32/0.03	16020445	407003		0,200	5		
		40	DS 941 AC-C40/0.03	16020452	407102		0,200	5		
		300	300	6	DS 941 AC-C6/0.3	16020536	407904		0,200	5
				10	DS 941 AC-C10/0.3	16020544	408000		0,200	5
				16	DS 941 AC-C16/0.3	16020551	408109		0,200	5
				20	DS 941 AC-C20/0.3	16020569	408208		0,200	5
				25	DS 941 AC-C25/0.3	16020577	408307		0,200	5
				32	DS 941 AC-C32/0.3	16020585	408406		0,200	5
				40	DS 941 AC-C40/0.3	16020593	408505		0,200	5

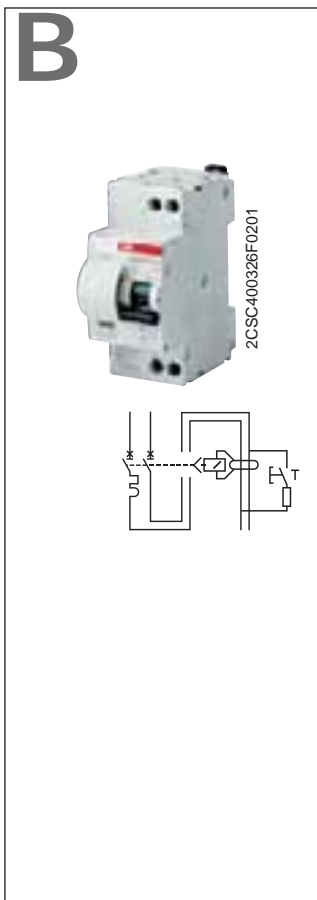

DS 941 A type, B characteristic

Function: protection in terminal single-phase circuit against overload and short-circuit currents; protection against the effects of sinusoidal alternating and direct pulsating earth fault currents; protection against indirect contacts and additional protection against direct contacts ($I_{\Delta n}=30$ mA); command and isolation of resistive and inductive loads, especially in presence of big length cables (typical of single-phase terminal circuits).

Application: residential, commercial, industrial.

Standard: IEC/EN 61009

$I_{cn}=4.5$ kA

Number of poles	Rated residual current $I_{\Delta n}$ mA	Rated current I_n A	Order details Type code	Order code	Bbn 8012542	Price 1 piece	Price group	Weight 1 piece kg	Pack unit pc.
1+N	10	6	DS 941 A-B6/0.01	16023555	424000			0,200	5
		10	DS 941 A-B10/0.01	16023563	424109			0,200	5
		16	DS 941 A-B16/0.01	16023571	424208			0,200	5
	30	6	DS 941 A-B6/0.03	16023753	424307			0,200	5
		10	DS 941 A-B10/0.03	16023761	424406			0,200	5
		16	DS 941 A-B16/0.03	16023779	424505			0,200	5
		20	DS 941 A-B20/0.03	16023787	424604			0,200	5
		25	DS 941 A-B25/0.03	16023795	424703			0,200	5
		32	DS 941 A-B32/0.03	16023803	424802			0,200	5
		40	DS 941 A-B40/0.03	16023811	424901			0,200	5

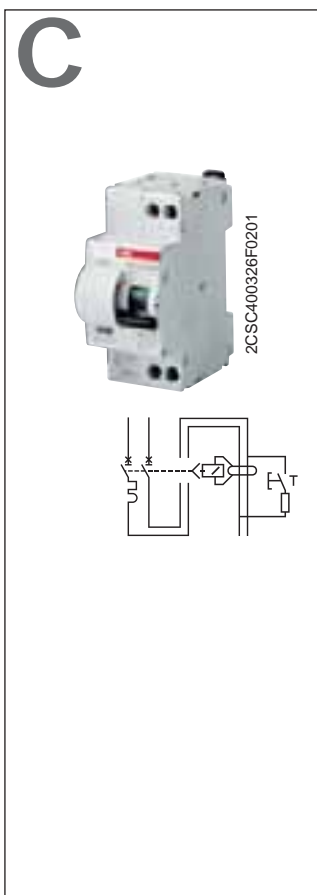

DS 941 A type, C characteristic

Function: protection in terminal single-phase circuit against overload and short-circuit currents; protection against the effects of sinusoidal alternating and direct pulsating earth fault currents; protection against indirect contacts and additional protection against direct contacts ($I_{\Delta n}=30$ mA); command and isolation of resistive and inductive loads.

Application: residential, commercial, industrial.

Standard: IEC/EN 61009

$I_{cn}=4.5$ kA

Number of poles	Rated residual current $I_{\Delta n}$ mA	Rated current I_n A	Order details Type code	Order code	Bbn 8012542	Price 1 piece	Price group	Weight 1 piece kg	Pack unit pc.
1+N	30	6	DS 941 A-C6/0.03	16024108	427803			0,200	5
		10	DS 941 A-C10/0.03	16024116	427902			0,200	5
		16	DS 941 A-C16/0.03	16024124	428008			0,200	5
		20	DS 941 A-C20/0.03	16024132	428107			0,200	5
		25	DS 941 A-C25/0.03	16024140	428206			0,200	5
		32	DS 941 A-C32/0.03	16024157	428305			0,200	5
	300	40	DS 941 A-C40/0.03	16024165	428404			0,200	5
		6	DS 941 A-C6/0.3	16024249	429203			0,200	5
		10	DS 941 A-C10/0.3	16024256	429302			0,200	5
		16	DS 941 A-C16/0.3	16024264	429401			0,200	5
		20	DS 941 A-C20/0.3	16024272	429500			0,200	5
		25	DS 941 A-C25/0.3	16024280	429609			0,200	5
		32	DS 941 A-C32/0.3	16024298	429708			0,200	5
		40	DS 941 A-C40/0.3	16024306	429807			0,200	5

B

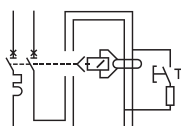

DS 951 AC type, B characteristic

Function: protection in terminal single-phase circuit against overload and short-circuit currents; protection against the effects of sinusoidal alternating earth fault currents; protection against indirect contacts and additional protection against direct contacts ($I_{\Delta n}=30$ mA); command and isolation of resistive and inductive loads, especially in presence of big length cables (typical of single-phase terminal circuits).

Application: residential, commercial, industrial.

Standard: IEC/EN 61009

$I_{cn}=6$ kA

Number of poles	Rated residual current $I_{\Delta n}$ mA	Rated current I_n A	Order details		Bbn	Price	Price	Weight	Pack
			Type code	Order code	8012542	1 piece	group	1 piece	unit
					EAN			kg	pc.
1+N	30	6	DS 951 AC-B6/0.03	16021005	410003			0,200	5
		10	DS 951 AC-B10/0.03	16021013	410102			0,200	5
		16	DS 951 AC-B16/0.03	16021021	410201			0,200	5
		20	DS 951 AC-B20/0.03	16021039	410300			0,200	5
		25	DS 951 AC-B25/0.03	16021047	410409			0,200	5
		32	DS 951 AC-B32/0.03	16021054	410508			0,200	5
		40	DS 951 AC-B40/0.03	16021062	410607			0,200	5

C

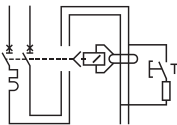

DS 951 AC type, C characteristic

Function: protection in terminal single-phase circuit against overload and short-circuit currents; protection against the effects of sinusoidal alternating earth fault currents; protection against indirect contacts and additional protection against direct contacts ($I\Delta n=30$ mA); command and isolation of resistive and inductive loads.

Application: residential, commercial, industrial.

Standard: IEC/EN 61009

$I_{cn}=6$ kA

Number of poles	Rated residual current $I\Delta n$ mA	Rated current I_n A	Order details Type code	Order code	Bbn 8012542	Price 1 piece	Price group	Weight 1 piece kg	Pack unit pc.
1+N	30	6	DS 951 AC-C6/0.03	16021351	413509			0,200	5
		10	DS 951 AC-C10/0.03	16021369	413608			0,200	5
		16	DS 951 AC-C16/0.03	16021377	413707			0,200	5
		20	DS 951 AC-C20/0.03	16021385	413806			0,200	5
		25	DS 951 AC-C25/0.03	16021393	413905			0,200	5
		32	DS 951 AC-C32/0.03	16021401	414001			0,200	5
		40	DS 951 AC-C40/0.03	16021419	414100			0,200	5
		100	6	DS 951 AC-C6/0.1	16021427	414209			0,200
	10		DS 951 AC-C10/0.1	16021435	414308			0,200	5
	16		DS 951 AC-C16/0.1	16021443	414407			0,200	5
	20		DS 951 AC-C20/0.1	16021450	414506			0,200	5
	25		DS 951 AC-CB25/0.1	16021468	414605			0,200	5
	32		DS 951 AC-C32/0.1	16021476	414704			0,200	5
	300	6	DS 951 AC-C6/0.3	16021492	414902			0,200	5
		10	DS 951 AC-C10/0.3	16021500	415008			0,200	5
		16	DS 951 AC-C16/0.3	16021518	415107			0,200	5
		20	DS 951 AC-C20/0.3	16021526	415206			0,200	5
		25	DS 951 AC-C25/0.3	16021534	415305			0,200	5
		32	DS 951 AC-C32/0.3	16021542	415404			0,200	5
	1000	40	DS 951 AC-C40/0.3	16021559	415503			0,200	5
		6	DS 951 AC-C6/1	16021633	416302			0,200	5
		10	DS 951 AC-C10/1	16021641	416401			0,200	5
		16	DS 951 AC-C16/1	16021658	416500			0,200	5
		20	DS 951 AC-C20/1	16021666	416609			0,200	5
25		DS 951 AC-C25/1	16021674	416708			0,200	5	
32		DS 951 AC-C32/1	16021682	416807			0,200	5	
40		DS 951 AC-C40/1	16021690	416906			0,200	5	

3

B



2CSC400326F0201

DS 951 A type, B characteristic

Function: protection in terminal single-phase circuit against overload and short-circuit currents; protection against the effects of sinusoidal alternating and direct pulsating earth fault currents; protection against indirect contacts and additional protection against direct contacts ($I_{\Delta n}=30$ mA); command and isolation of resistive and inductive loads, especially in presence of big length cables (typical of single-phase terminal circuits).

Application: residential, commercial, industrial.

Standard: IEC/EN 61009

$I_{cn}=6$ kA

Number of poles	Rated residual current	Rated current	Order details		Bbn 8012542	Price 1 piece	Price group	Weight 1 piece	Pack unit
			$I_{\Delta n}$ mA	In A					
1+N	10	6	6	DS 951 A-B6/0.01	16226776	968900		0,200	5
			10	DS 951 A-B10/0.01	16226784	969006		0,200	5
			16	DS 951 A-B16/0.01	16226792	969105		0,200	5
	30	6	6	DS 951 A-B6/0.03	16024751	431305		0,200	5
			10	DS 951 A-B10/0.03	16024769	431404		0,200	5
			16	DS 951 A-B16/0.03	16024777	431503		0,200	5
			20	DS 951 A-B20/0.03	16024785	431602		0,200	5
			25	DS 951 A-B25/0.03	16024793	431701		0,200	5
			32	DS 951 A-B32/0.03	16024801	431800		0,200	5
			40	DS 951 A-B40/0.03	16024819	431909		0,200	5

C



DS 951 AP-R, A type, C characteristic

Function: protection against the effects of sinusoidal alternating earth fault currents, providing the best compromise between safety and continuity in the service thanks to the resistance to unwanted trippings; protection against indirect contacts and additional protection against direct ($I_{\Delta n}=30$ mA) contacts; protection and isolation of resistive and inductive loads.

Application: residential, commercial, industrial.

Standard: IEC/EN 61009

$I_{cn}=6$ KA

Surge current resistance (wave 8/20)=3000A

Number of poles	Rated residual current	Rated current	Order details		Bbn 8012542	Price 1 piece	Price group	Weight 1 piece	Pack unit
			$I_{\Delta n}$ mA	In A					
1+N	30	6	6	DS951 A-C6/0,03 AP-R	16025626	008309		0.200	5
			10	DS951 A-C10/0,03 AP-R	16025634	008408		0.200	5
			16	DS951 A-C16/0,03 AP-R	16025642	008507		0.200	5
			20	DS951 A-C20/0,03 AP-R	16025659	010005		0.200	5
			25	DS951 A-C25/0,03 AP-R	16025667	010104		0.200	5
			32	DS951 A-C32/0,03 AP-R	16025675	010203		0.200	5

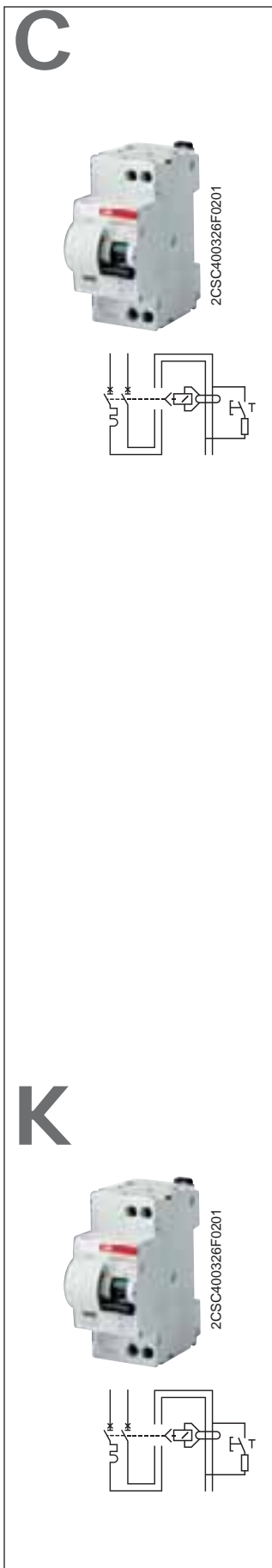

DS 951 A type, C characteristic

Function: protection in terminal single-phase circuit against overload and short-circuit currents; protection against the effects of sinusoidal alternating and direct pulsating earth fault currents; protection against indirect contacts and additional protection against direct contacts ($\Delta n=30$ mA); command and isolation of resistive and inductive loads.

Application: residential, commercial, industrial.

Standard: IEC/EN 61009; $I_{cn}=6$ kA

Number of poles	Rated residual current Δn mA	Rated current I_n A	Order details Type code	Order code	Bbn 8012542	Price 1 piece	Price group	Weight 1 piece	Pack unit
					EAN	kg	pc.		
1+N	10	6	DS 951 A-C6/0.01	16226800	969204			0,200	5
		10	DS 951 A-C10/0.01	16226818	969303			0,200	5
		16	DS 951 A-C16/0.01	16226826	969402			0,200	5
	30	6	DS 951 A-C6/0.03	16025154	434801			0,200	5
		10	DS 951 A-C10/0.03	16025162	434900			0,200	5
		16	DS 951 A-C16/0.03	16025170	435006			0,200	5
		20	DS 951 A-C20/0.03	16025188	435105			0,200	5
		25	DS 951 A-C25/0.03	16025196	435204			0,200	5
		32	DS 951 A-C32/0.03	16025204	435303			0,200	5
	100	40	DS 951 A-C40/0.03	16025212	435402			0,200	5
		6	DS 945 A-C6/0.1	16025220	435501			0,200	5
		10	DS 951 A-C10/0.1	16025238	435600			0,200	5
		16	DS 951 A-C16/0.1	16025246	435709			0,200	5
		20	DS 951 A-C20/0.1	16025253	435808			0,200	5
		25	DS 951 A-C25/0.1	16025261	435907			0,200	5
	300	32	DS 951 A-C32/0.1	16025279	436003			0,200	5
		40	DS 951 A-C40/0.1	16025287	436102			0,200	5
		6	DS 951 A-C6/0.3	16025295	436201			0,200	5
		10	DS 951 A-BC10/0.3	16025303	436300			0,200	5
		16	DS 951 A-BC16/0.3	16025311	436409			0,200	5
		20	DS 951 A-C20/0.3	16025329	436508			0,200	5
	500	25	DS 951 A-C25/0.3	16025337	436607			0,200	5
		32	DS 951 A-C32/0.3	16025345	436706			0,200	5
		40	DS 951 A-C40/0.3	16025352	436805			0,200	5
6		DS 951 A-C6/0.5	16025360	436904			0,200	5	
10		DS 951 A-C10/0.5	16025378	437000			0,200	5	
16		DS 951 A-C16/0.5	16025386	437109			0,200	5	
20		DS 951 A-C20/0.5	16025394	437208			0,200	5	
25		DS 951 A-C25/0.5	16025402	437307			0,200	5	
	32	DS 951 A-C32/0.5	16025410	437406			0,200	5	
	40	DS 951 A-C40/0.5	16025428	437505			0,200	5	

DS 951 AC type, K characteristic

Function: protection in terminal single-phase circuit against overload and short-circuit currents; protection against the effects of sinusoidal alternating earth fault currents; protection against indirect contacts and additional protection against direct contacts ($\Delta n=30$ mA); command and isolation of the circuits like motors, transformer and auxiliary circuits.

Application: residential, commercial, industrial.

Standard: IEC/EN 61009, IEC/EN 60947-2; $I_{cn}=6$ kA

Number of poles	Rated residual current Δn mA	Rated current I_n A	Order details Type code	Order code	Bbn 8012542	Price 1 piece	Price group	Weight 1 piece	Pack unit
					EAN	kg	pc.		
1+N	30	6	DS 951 AC-K6/0.03	16025501	519904			0,200	5
		10	DS 951 AC-K10/0.03	16025519	520009			0,200	5
		16	DS 951 AC-K16/0.04	16025527	520108			0,200	5
		20	DS 951 AC-K20/0.04	16025535	520207			0,200	5
		25	DS 951 AC-K25/0.05	16025543	520306			0,200	5
	300	6	DS 951 AC-K6/0.3	16025568	520504			0,200	5
		10	DS 951 AC-K10/0.3	16025576	520603			0,200	5
		16	DS 951 AC-K16/0.3	16025584	520702			0,200	5
		20	DS 951 AC-K20/0.3	16025592	520801			0,200	5
		25	DS 951 AC-K25/0.3	16025600	520900			0,200	5

B



2CSC400326F0201

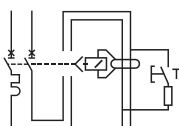

DS 971 AC type, B characteristic

Function: protection in terminal single-phase circuit against overload and short-circuit currents; protection against the effects of sinusoidal alternating earth fault currents; protection against indirect contacts and additional protection against direct contacts ($I_{\Delta n}=30$ mA); command and isolation of resistive and inductive loads, especially in presence of big length cables (typical of single-phase terminal circuits).

Application: residential, commercial, industrial.

Standard: IEC/EN 61009

$I_{cn}=10$ kA

Number of poles	Rated residual current $I_{\Delta n}$ mA	Rated current I_n A	Order details		Bbn	Price	Price	Weight	Pack
			Type code	Order code	8012542	1 piece	group	1 piece	unit
					EAN			kg	pc.
1+N	30	6	DS 971 AC-B6/0.03	16021955	417002			0,200	5
		10	DS 971 AC-B10/0.03	16021963	417101			0,200	5
		16	DS 971 AC-B16/0.03	16021971	417200			0,200	5
		20	DS 971 AC-B20/0.03	16021989	417309			0,200	5
		25	DS 971 AC-B25/0.03	16021997	417408			0,200	5
		32	DS 971 AC-B32/0.03	16022003	417507			0,200	5

C

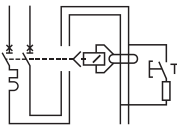

DS 971 AC type, C characteristic

Function: protection in terminal single-phase circuit against overload and short-circuit currents; protection against the effects of sinusoidal alternating earth fault currents; protection against indirect contacts and additional protection against direct contacts ($I\Delta n=30$ mA); command and isolation of resistive and inductive loads.

Application: residential, commercial, industrial.

Standard: IEC/EN 61009

$I_{cn}=10$ kA

Number of poles	Rated residual current $I\Delta n$ mA	Rated current I_n A	Order details Type code	Order code	Bbn 8012542	Price 1 piece	Price group	Weight 1 piece kg	Pack unit pc.
1+N	30	6	DS 971 AC-C6/0.03	16023159	420507			0,200	5
		10	DS 971 AC-C10/0.03	16023167	420606			0,200	5
		16	DS 971 AC-C16/0.03	16023175	420705			0,200	5
		20	DS 971 AC-C20/0.03	16023183	420804			0,200	5
		25	DS 971 AC-C25/0.03	16023191	420903			0,200	5
		32	DS 971 AC-C32/0.03	16023209	421009			0,200	5
	100	6	DS 971 AC-C6/0.1	16023225	421207			0,200	5
		10	DS 971 AC-C10/0.1	16023233	421306			0,200	5
		16	DS 971 AC-C16/0.1	16023241	421405			0,200	5
		20	DS 971 AC-C20/0.1	16023258	421504			0,200	5
		25	DS 971 AC-C25/0.1	16023266	421603			0,200	5
		32	DS 971 AC-C32/0.1	16023274	421702			0,200	5
	300	6	DS 971 AC-C6/0.3	16023290	421900			0,200	5
		10	DS 971 AC-C10/0.3	16023308	422006			0,200	5
		16	DS 941 AC-C16/0.3	16023316	422105			0,200	5
		20	DS 971 AC-C20/0.3	16023324	422204			0,200	5
		25	DS 971 AC-C25/0.3	16023332	422303			0,200	5
		32	DS 971 AC-C32/0.3	16023340	422402			0,200	5
	1000	6	DS 971 AC-C6/1	16023431	423300			0,200	5
		10	DS 971 AC-C10/1	16023449	423409			0,200	5
		16	DS 971 AC-C16/1	16023456	423508			0,200	5
		20	DS 971 AC-C20/1	16023464	423607			0,200	5
		25	DS 971 AC-C25/1	16023472	423706			0,200	5
		32	DS 971 AC-C32/1	16023480	423805			0,200	5

3

B



2CSC400326F0201

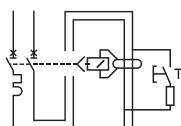

DS 971 A type, B characteristic

Function: protection in terminal single-phase circuit against overload and short-circuit currents; protection against the effects of sinusoidal alternating and direct pulsating earth fault currents; protection against indirect contacts and additional protection against direct contacts ($I_{\Delta n}=30$ mA); command and isolation of resistive and inductive loads, especially in presence of big length cables (typical of single-phase terminal circuits).

Application: residential, commercial, industrial.

Standard: IEC/EN 61009

$I_{cn}=10$ kA

Number of poles	Rated residual current $I_{\Delta n}$ mA	Rated current I_n A	Order details	Order code	Bbn 8012542	Price 1 piece	Price group	Weight 1 piece	Pack unit
			Type code		EAN			kg	pc.
1+N	30	6	DS 971 A-B6/0.03	16025758	438304			0,200	5
		10	DS 971 A-B10/0.03	16025766	438403			0,200	5
		16	DS 971 A-B16/0.03	16025774	438502			0,200	5
		20	DS 971 A-B20/0.03	16025782	438601			0,200	5
		25	DS 971 A-B25/0.03	16025790	438700			0,200	5
		32	DS 971 A-B32/0.03	16025808	438809			0,200	5

3

C

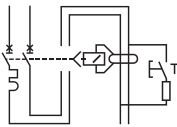

DS 971 A type, C characteristic

Function: protection in terminal single-phase circuit against overload and short-circuit currents; protection against the effects of sinusoidal alternating and direct pulsating earth fault currents; protection against indirect contacts and additional protection against direct contacts ($I_{\Delta n}=30$ mA); command and isolation of resistive and inductive loads.

Application: residential, commercial, industrial.

Standard: IEC/EN 61009

$I_{cn}=10$ kA

Number of poles	Rated residual current $I_{\Delta n}$ mA	Rated current I_n A	Order details Type code	Order code	Bbn 8012542 EAN	Price 1 piece	Price group	Weight 1 piece kg	Pack unit pc.
1+N	30	6	DS 971 A-C6/0.03	16026657	441809			0,200	5
		10	DS 971 A-C10/0.03	16026665	441908			0,200	5
		16	DS 971 A-C16/0.03	16026673	442004			0,200	5
		20	DS 971 A-C20/0.03	16026681	442103			0,200	5
		25	DS 971 A-C25/0.03	16026699	442202			0,200	5
		32	DS 971 A-C32/0.03	16026707	442301			0,200	5
	100	6	DS 971 A-C6/0.1	16026723	442509			0,200	5
		10	DS 971 A-C10/0.1	16026731	442608			0,200	5
		16	DS 971 A-C16/0.1	16026749	442707			0,200	5
		20	DS 971 A-C20/0.1	16026756	442806			0,200	5
		25	DS 971 A-C25/0.1	16026764	442905			0,200	5
		32	DS 971 A-C32/0.1	16026772	443001			0,200	5
	300	6	DS 971 A-C6/0.3	16026798	443209			0,200	5
		10	DS 971 A-C10/0.3	16026806	443308			0,200	5
		16	DS 941 A-C16/0.3	16026814	443407			0,200	5
		20	DS 971 A-C20/0.3	16026822	443506			0,200	5
		25	DS 971 A-C25/0.3	16026830	443605			0,200	5
		32	DS 971 A-C32/0.3	16026848	443704			0,200	5
500	6	DS 971 A-C6/0.5	16026863	443902			0,200	5	
	10	DS 971 A-C10/0.5	16026871	444008			0,200	5	
	16	DS 971 A-C16/0.5	16026889	444107			0,200	5	
	20	DS 971 A-C20/0.5	16026897	444206			0,200	5	
	25	DS 971 A-C25/0.5	16026905	444305			0,200	5	
	32	DS 971 A-C32/0.5	16026913	444404			0,200	5	

3

3

TECHNICAL CHARACTERISTICS

	Standards			
Electrical features	Type (wave form of the earth leakage sensed)			
	Poles			
	Rated current I_n		A	
	Rated sensitivity $I_{\Delta n}$		A	
	Rated voltage U_e		V	
	Insulation voltage U_i			
	Max. operating voltage		V	
	Min. operating voltage		V	
	Rated frequency		Hz	
	Rated breaking capacity acc. to IEC/EN 61009	ultimate I_{cn}		A
	Rated breaking capacity acc. to IEC/EN 60947-2 1P+N @230 VAC, 2P, 3P, 4P @400 VAC	ultimate I_{cu} service I_{cs}		kA kA
	Rated residual breaking capacity $I_{\Delta m}$			kA
	Rated impulse withstand voltage (1.2/50) U_{imp}			kV
	Dielectric test voltage at ind. freq. for 1 min.			kV
	Thermomagnetic release characteristic	B: $3 I_n \leq I_m \leq 5 I_n$ C: $5 I_n \leq I_m \leq 10 I_n$		
	Surge current resistance (wave 8/20)			A
Mechanical features	Toggle			
	Electrical life			
	Mechanical life			
	Protection degree	housing terminals		
	Tropicalization acc. to IEC /EN 60068-2	humid heat constant climatic conditions variable climatic conditions		°C/RH °C/RH °C/RH
	Reference temperature for setting of thermal element			°C
	Ambient temperature (with daily average $\leq +35$ °C)			°C
	Storage temperature			°C
Installation	Terminal type	top bottom		
	Terminal size top/bottom for cables	1P+N line side load side	mm ² mm ² mm ²	
	Tightening torque top/bottom	1P+N	N*m	
	Mounting			
Dimensions and weight	Dimensions (H x D x W)	1P+N	mm	
	Weight	1P+N	g	
Combination with auxiliary elements	Combinable with:	auxiliary contact signal contact shunt trip undervoltage release		



3

DS 271 AC	IEC 61009, BSEN 61009-2-2	DS 271 A
AC		A
0.01-0.03-0.1	1P+N $6 \leq I_n \leq 32$	0.01-0.03
	230-240	
	500	
	254	
	85	
	50...60	
	10000	
	-	
	7.5	
	6	
	5	
	2.5	
	■	
	■	
	250	
	black sealable in on-off position	
	10000	
	20000	
	IP4X	
	IP2X	
	28 cycles with 55/95...100	
	23/83 - 40/93 - 55/20	
	25/95 - 40/95	
	30	
	-25...+55	
	-25...+70	
	cage (shock protected)	
	cage (shock protected)	
	-	
	L1: 1 up to 25; N: flexible 4; FE: flexible 0.5	
	L1 and N: 1 up to 10	
	2 top; 1.2 bottom	
	on DIN rail EN 60715 (35 mm) by means of fast clip device	
	120 x 67.6 x 17.5	
	205	
	no	
	no	
	no	
	no	

B

DS 271 AC type, B and C characteristics

Function: protection against overload and short-circuit currents; protection against the effects of sinusoidal alternating earth fault currents; protection against indirect contacts and additional protection against direct contacts ($I_{\Delta n}=30$ mA); command and isolation of resistive and inductive loads.

Application: residential, commercial, industrial.

Standard: IEC 61009, BSEN61009-2-2

$I_{cn}=10$ kA



Characteristics/ Curve	Rated residual current $I_{\Delta n}$ mA	Rated current I_n A	Order details Type code	Order code	Bbn 8012542	Price 1 piece	Price group	Weight 1 piece kg	Pack unit pc.
B	10	6	DS271 AC-B6/0.01 ELN	2CSR175092R0065	036753			0.205	1
		10	DS271 AC-B10/0.01 ELN	2CSR175092R0105	036852			0.205	1
		16	DS271 AC-B16/0.01 ELN	2CSR175092R0165	036951			0.205	1
		20	DS271 AC-B20/0.01 ELN	2CSR175092R0205	037057			0.205	1
		25	DS271 AC-B25/0.01 ELN	2CSR175092R0255	037156			0.205	1
		32	DS271 AC-B32/0.01 ELN	2CSR175092R0325	037255			0.205	1
	30	6	DS271 AC-B6/0.03 ELN	2CSR175092R1065	037354			0.205	1
		10	DS271 AC-B10/0.03 ELN	2CSR175092R1105	037453			0.205	1
		16	DS271 AC-B16/0.03 ELN	2CSR175092R1165	037552			0.205	1
		20	DS271 AC-B20/0.03 ELN	2CSR175092R1205	037651			0.205	1
		25	DS271 AC-B25/0.03 ELN	2CSR175092R1255	037750			0.205	1
		32	DS271 AC-B32/0.03 ELN	2CSR175092R1325	037859			0.205	1/20

C

C	10	6	DS271 AC-C6/0.01 ELN	2CSR175092R0064	038559			0.205	1
		10	DS271 AC-C10/0.01 ELN	2CSR175092R0104	038658			0.205	1
		16	DS271 AC-C16/0.01 ELN	2CSR175092R0164	038757			0.205	1/20
		20	DS271 AC-C20/0.01 ELN	2CSR175092R0204	038856			0.205	1
		25	DS271 AC-C25/0.01 ELN	2CSR175092R0254	038955			0.205	1
		32	DS271 AC-C32/0.01 ELN	2CSR175092R0324	039051			0.205	1/20
	30	6	DS271 AC-C6/0.03 ELN	2CSR175092R1064	039150			0.205	1
		10	DS271 AC-C10/0.03 ELN	2CSR175092R1104	039259			0.205	1
		16	DS271 AC-C16/0.03 ELN	2CSR175092R1164	039358			0.205	1
		20	DS271 AC-C20/0.03 ELN	2CSR175092R1204	039457			0.205	1
		25	DS271 AC-C25/0.03 ELN	2CSR175092R1254	039556			0.205	1
		32	DS271 AC-C32/0.03 ELN	2CSR175092R1324	039655			0.205	1
	100	6	DS271 AC-C6/0.1 ELN	2CSR175092R2064	039754			0.205	1
		10	DS271 AC-C10/0.1 ELN	2CSR175092R2104	039853			0.205	1/20
		16	DS271 AC-C16/0.1 ELN	2CSR175092R2164	039952			0.205	1/20
		20	DS271 AC-C20/0.1 ELN	2CSR175092R2204	040057			0.205	1/20
		25	DS271 AC-C25/0.1 ELN	2CSR175092R2254	040156			0.205	1
		32	DS271 AC-C32/0.1 ELN	2CSR175092R2324	040255			0.205	1
	300	6	DS271 AC-C6/0.3 ELN	2CSR175092R3064	040354			0.205	1
		10	DS271 AC-C10/0.3 ELN	2CSR175092R3104	040453			0.205	1
		16	DS271 AC-C16/0.3 ELN	2CSR175092R3164	040552			0.205	1
		20	DS271 AC-C20/0.3 ELN	2CSR175092R3204	040651			0.205	1
		25	DS271 AC-C25/0.3 ELN	2CSR175092R3254	040750			0.205	1
		32	DS271 AC-C32/0.3 ELN	2CSR175092R3324	040859			0.205	1





DS 271 A type, B and C characteristics

Function: protection against overload and short-circuit currents; protection against the effects of sinusoidal alternating and direct pulsating earth fault currents; protection against indirect contacts and additional protection against direct contacts ($I_{\Delta n}=30$ mA); command and isolation of resistive and inductive loads.

Application: commercial, industrial.

Standard: IEC 61009, BSEN61009-2-2

$I_{cn}=10$ kA

Characteristics/ Curve	Rated residual current $I_{\Delta n}$ mA	Rated current I_n A	Order details		Bbn 8012542	Price 1 piece	Price group	Weight 1 piece kg	Pack unit pc.
			Type code	Order code					
B	10	6	DS271 A-B6/0.01 ELN	2CSR175192R0065	032557			0.205	1
		10	DS271 A-B10/0.01 ELN	2CSR175192R0105	032656			0.205	1
		16	DS271 A-B16/0.01 ELN	2CSR175192R0165	032755			0.205	1
		20	DS271 A-B20/0.01 ELN	2CSR175192R0205	032854			0.205	1
		25	DS271 A-B25/0.01 ELN	2CSR175192R0255	032953			0.205	1
		32	DS271 A-B32/0.01 ELN	2CSR175192R0325	033059			0.205	1
	30	6	DS271 A-B6/0.03 ELN	2CSR175192R1065	033158			0.205	1
		10	DS271 A-B10/0.03 ELN	2CSR175192R1105	033257			0.205	1
		16	DS271 A-B16/0.03 ELN	2CSR175192R1165	033356			0.205	1
		20	DS271 A-B20/0.03 ELN	2CSR175192R1205	033455			0.205	1
		25	DS271 A-B25/0.03 ELN	2CSR175192R1255	033554			0.205	1
		32	DS271 A-B32/0.03 ELN	2CSR175192R1325	033653			0.205	1



C	10	6	DS271 A-C6/0.01 ELN	2CSR175192R0064	034353			0.205	1
		10	DS271 A-C10/0.01 ELN	2CSR175192R0104	034452			0.205	1
		16	DS271 A-C16/0.01 ELN	2CSR175192R0164	034551			0.205	1
		20	DS271 A-C20/0.01 ELN	2CSR175192R0204	034650			0.205	1
		25	DS271 A-C25/0.01 ELN	2CSR175192R0254	034759			0.205	1
		32	DS271 A-C32/0.01 ELN	2CSR175192R0324	034858			0.205	1
	30	6	DS271 A-C6/0.03 ELN	2CSR175192R1064	034957			0.205	1
		10	DS271 A-C10/0.03 ELN	2CSR175192R1104	035053			0.205	1/20
		16	DS271 A-C16/0.03 ELN	2CSR175192R1164	035152			0.205	1/20
		20	DS271 A-C20/0.03 ELN	2CSR175192R1204	035251			0.205	1/20
		25	DS271 A-C25/0.03 ELN	2CSR175192R1254	035350			0.205	1
		32	DS271 A-C32/0.03 ELN	2CSR175192R1324	035459			0.205	1
	100	6	DS271 A-C6/0.1 ELN	2CSR175192R2064	035558			0.205	1
		10	DS271 A-C10/0.1 ELN	2CSR175192R2104	035657			0.205	1
		16	DS271 A-C16/0.1 ELN	2CSR175192R2164	035756			0.205	1
		20	DS271 A-C20/0.1 ELN	2CSR175192R2204	035855			0.205	1
		25	DS271 A-C25/0.1 ELN	2CSR175192R2254	035954			0.205	1
		32	DS271 A-C32/0.1 ELN	2CSR175192R2324	036050			0.205	1
	300	6	DS271 A-C6/0.3 ELN	2CSR175192R3064	036159			0.205	1
		10	DS271 A-C10/0.3 ELN	2CSR175192R3104	036258			0.205	1
		16	DS271 A-C16/0.3 ELN	2CSR175192R3164	036357			0.205	1
		20	DS271 A-C20/0.3 ELN	2CSR175192R3204	036456			0.205	1
		25	DS271 A-C25/0.3 ELN	2CSR175192R3254	036555			0.205	1
		32	DS271 A-C32/0.3 ELN	2CSR175192R3324	036654			0.205	1

The range of DDA 60, 70 and selective 90 RCD blocks for the S 290 series includes 100A devices suitable for assembly with MCBs in the S 290 series of type C only.

The new DDA 800 RCD blocks for protecting people and electrical installations are useful when a higher breaking capacity is required. Assembling a DDA 800 RCD block with an S 800 N or S 800 S MCB creates an RCBO with a breaking capacity of 36 kA and 50 kA respectively. The RCD-blocks must be mounted on the right side of the MCB, so that the available accessories can be mounted on the left side. DDA 800 RCD blocks are available in AC and A, A AP-R (high immunity) and A selective types. DS 800 RCBOs are available, only in the size of 125 A, in A, AP-R (high immunity) and A selective types.

In compliance with IEC EN 61009, which establishes that the RCD blocks can be assembled with an MCB only once, the S 290 series DDA blocks have a mechanical pin which prevents disassembly once inserted.

In contrast, RCD blocks for the S 800 series which conform to IEC EN 60947-2 app. B do not have unlosable coupling elements.

DDA RCD blocks for the S 290 and S 800 series are not sen-

sitive to impulsive atmospheric and operational discharges, therefore, they are not subject to unwanted tripping in accordance with IEC EN 61008, and IEC EN 61009, even with 8/20 μ s wave up to 250 A.



2CSC400170F0201

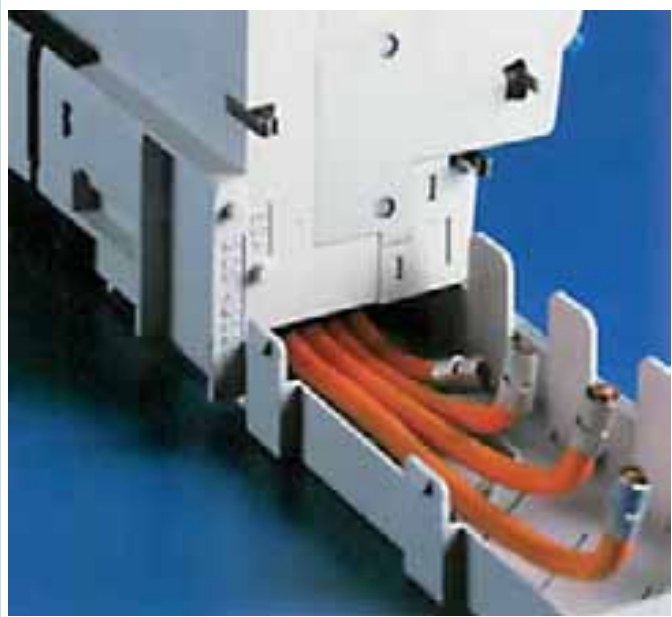

2CSC400273F0201



2CSC400274F0201



Index

Technical features of RCDs-blocks for MCBs S 290 series	3/58
Selection tables of RCDs-blocks for MCBs S 290 series DDA 60, DDA 70 and DDA 90 for MCBs S 290 series	3/60
Technical features of RCDs-blocks for MCBs S800 series	3/62
Selection tables of RCD-blocks for MCBs S800 series DDA 800 for MCBs S800 series	3/64
Technical features of DS800 RCBOs series	3/68
Selection tables of DS800 RCBOs series DS800 RCBOs series.....	3/70

3

TECHNICAL FEATURES			
	Standards		
Electrical features	Type (wave form of the earth leakage sensed)		
	Poles		
	Rated current I _n		A
	Rated sensitivity I _{Δn}		A
	Rated voltage U _N		V
	Insulation voltage U _i		V
	Max. operating voltage of circuit test		V
	Min. operating voltage of circuit test		V
	Rated frequency		Hz
	Rated breaking capacity (I _{cn}) acc. to IEC /EN 61009		A
	Rated breaking capacity (I _{cn}) acc. to IEC/EN 60947-2		A
	Rated residual breaking capacity I _{Δm}		kA
	Rated impulse withstand voltage (1.2/50) U _{imp}		kV
	Dielectric test voltage at ind. freq. for 1 min.		kV
Surge current resistance (wave 8/20)		A	
Mechanical features	Toggle		
	Electrical life		
	Mechanical life		
	Protection degree	housing terminals	
	Tropicalization acc. to IEC /EN 60068-2	humid heat constant climatic conditions variable climatic conditions	°C/RH °C/RH °C/RH
	Ambient temperature (with daily average ≤ +35 °C)		°C
	Storage temperature		°C
	Installation	Terminal size for cables	
Tightening torque			N*m
Mounting			
Dimensions and weight	Dimensions (H x D x W)	2P 3P/4P	mm mm
	Weight	2P	g
		3P/4P	g
Combination with auxiliary elements	Combinable with:	S 290 C characteristic	
		S 290 D and K characteristics	

System **Technical features**
pro M compact® RCD-blocks for MCBs S 290 series

DDA 60
DDA 70
DDA 90



DDA 60	DDA 70	DDA 90
	IEC/EN 61009 Ann. G	
AC	A	A
	2P, 4P	
	100	
0.03-0.3	0.03-0.3	0.3-1
	230/400	
	500	
	240(2P), 415(4P)	
	100(2P), 175(4P)	
	50...60	
	according to the breaking capacity of the associated MCB	
	according to the breaking capacity of the associated MCB	
	7.5	
	4	
	2.5	
250	1000	3000
	black operating from ON-OFF position	
	10000	
	20000	
	IP4X	
	IP2X	
	28 cycles with 55/95...100	
	23/83 - 40/93 - 55/20	
	25/95 - 40/95	
	-25...+45	
	-40...+60	
	50	
	3.5	
	on DIN rail EN 60715 (35 mm) by means of rapid fixing device	
	94 x 68 x 61	
	94 x 68 x 90	
	325	
	600	
	yes	
	no	

3

AC

3



2CSC400167F0201

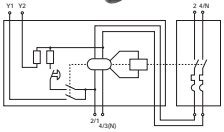

2CSC400169F0201

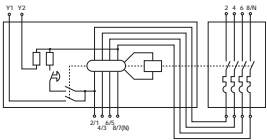

DDA 60 AC type for MCBs S 290

Function: RCD-block for assembly on site with MCBs S 290 series only in C characteristic. Protection against the effects of sinusoidal alternating earth fault currents; protection against indirect contacts and additional protection against direct (with $I\Delta n=30\text{ mA}$) contacts.

Additional terminals for remote tripping are available.

Application: commercial, industrial.

Standard: IEC/EN 61009 Ann. G

Number of poles	Rated residual current $I\Delta n$ mA	Rated current I_n A	Order details		Bbn	Price	Price	Weight	Pack
			Type code	Order code	8012542	1 piece	group	1 piece	unit
					EAN			kg	pc.
2	0.03	100	DDA62 100 30MA	36229002	183307			0.325	1
	0.3	100	DDA62 100 300MA	36229010	183505			0.325	1
4	0.03	100	DDA 64 100 30MA	36229044	183901			0.600	1
	0.3	100	DDA 64 100 300MA	36229051	184106			0.600	1

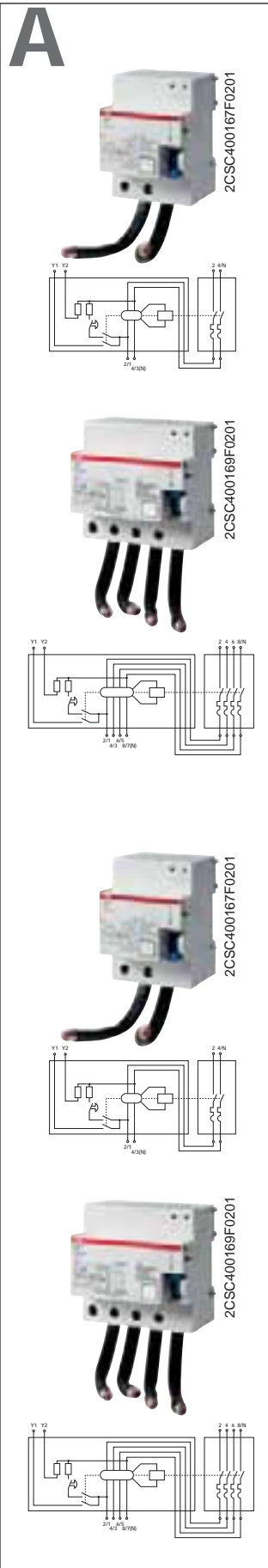

DDA 70 A type for MCBs S 290

Function: RCD-block for assembly on site with MCBs S 290 series only in C characteristic. Protection against the effects of sinusoidal alternating and direct pulsating earth fault currents; protection against indirect contacts and additional protection against direct (with $I\Delta n=30$ mA) contacts. Additional terminals for remote tripping are available.

Application: commercial, industrial.

Standard: IEC/EN 61009 Ann. G

Number of poles	Rated residual current $I\Delta n$ mA	Rated current I_n A	Order details		Bbn	Price	Price	Weight	Pack
			Type code	Order code	8012542	1 piece	group	1 piece	unit
					EAN		kg	pc.	
2	0.03	100	DDA 72 100 30MA	36229069	184304		0.325	1	
	0.3	100	DDA 72 100 300MA	36229077	184403		0.325	1	

4	0.03	100	DDA 74 100 30MA	36229101	184700		0.600	1	
	0.3	100	DDA 74 100 300MA	36229119	184809		0.600	1	

DDA 90 A selective type for MCBs S 290

Function: RCD-block for assembly on site with MCBs S 290 series (only in C characteristic). Protection against the effects of sinusoidal alternating and direct pulsating earth fault currents with an intentional tripping delay, which permits to realize the selectivity with downstream instantaneous devices (for more information about selectivity see the technical guide).

Additional terminals for remote tripping are available.

Application: commercial, industrial.

Standard: IEC/EN 61009 Ann. G

2	0.3	100	DDA 92 100 300MA S	36229127	185103		0.325	1	
	1	100	DDA 92 100 1A S	36229135	185509		0.325	1	

4	0.3	100	DDA 94 100 300MA S	36229168	185905		0.600	1	
	1	100	DDA 94 100 1A S	36229176	186001		0.600	1	

3

TECHNICAL FEATURES				
Standards				
Electrical features	Type (wave form of the earth leakage sensed)			
	Poles			
	Rated current I _n		A	
	Rated sensitivity I _{Δn}		A	
	Rated voltage U _e		V	
	Insulation voltage U _i		V	
	Max. operating voltage of circuit test		V	
	Min. operating voltage of circuit test		V	
	Rated frequency		Hz	
	Rated breaking capacity (I _{cn}) acc. to IEC /EN 60947-2		A	
	Rated residual breaking capacity I _{Δm}	with S 800 N	kA	
		with S 800 S	kA	
	Rated impulse withstand voltage (1.2/50) U _{imp}		kV	
	Dielectric test voltage at ind. freq. for 1 min.		kV	
Surge current resistance (wave 8/20)		A		
Mechanical features	Toggle			
	Electrical life			
	Mechanical life			
	Protection degree	housing terminals		
	Tropicalization acc. to IEC /EN 60068-2	humid heat	°C/RH	
		constant climatic conditions	°C/RH	
		variable climatic conditions	°C/RH	
	Ambient temperature (with daily average ≤ +35 °C)		°C	
	Storage temperature		°C	
	Terminal size for cables	flexible rigid	mm ² mm ²	
Tightening torque		N*m		
Mounting				
Dimensions and weight	Dimensions (H x D x W)	2P	mm	
		3P	mm	
		4P	mm	
	Weight	2P	g	
		3P	g	
4P		g		
Combination with MCBs	Combinable with:	S 800 N S 800 S		

System **Technical features**
pro M compact® **RCDs-blocks for MCBs S800 series**

DDA 800



3

DDA 800 AC	DDA 800 A		DDA 800 A AP-R	DDA 800 A S	
IEC/EN 60947-2 Ann. B					
AC	A		A	A	
63	63	100	63-100	63	100
0.03-0.3	0.03-0.3-0.5	0.3-0.5	0.03	0.3-1	0.3-0.5*-1
230/400 - 240/415 - 400/690					
690					
690					
195					
50...60					
according to the breaking capacity of the associated MCB					
according to the Icu of the associated MCB					
according to the Icu of the associated MCB					
6					
2.5					
250			3000	5000	
blue operating just from OFF position					
10000					
20000					
IP4X					
IP2X					
28 cycles with 55/95...100					
23/83 - 40/93 - 55/20					
25/95 - 40/95					
-25...+60					
-40...+70					
6...50					
6...70					
min. 3 / max. 4					
on DIN rail EN 60715 (35 mm) by means of rapid fixing device					
108.2 x 82.3 x 81					
108.2 x 82.3 x 117					
108.2 x 82.3 x 117					
300 for 63 A - 415 for 100 A					
400 for 63 A - 640 for 100 A					
460 for 63 A - 765 for 100 A					
yes					
yes					

* only on 3P and 4P versions

AC



2CSC400177F0201

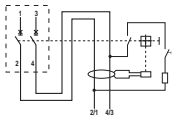

2CSC400178F0201

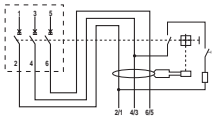

2CSC400179F0201

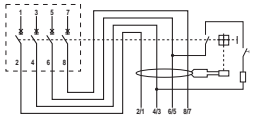

DDA 800 AC type for MCBs S800

Function: RCD-block for assembly on site with MCBs S800 series up to 63A. Protection against the effects of sinusoidal alternating earth fault currents; protection against indirect contacts and additional protection against direct (with $I_{\Delta n}=30$ mA) contacts.

Application: commercial, industrial.

Standard: IEC/EN 60947-2 Ann. B

Number of poles	Rated residual current $I_{\Delta n}$ mA	Rated current I_n A	Order details		Bbn 8012542	Price 1 piece	Price group	Weight 1 piece kg	Pack unit pc.
			Type code	Order code					
2	30	63	DDA802AC-63/0.03	2CSB802001R1630	919704			0.300	1
	300	63	DDA802AC-63/0.3	2CSB802001R3630	919902			0.300	1
3	30	63	DDA803AC-63/0.03	2CSB803001R1630	922001			0.400	1
	300	63	DDA803AC-63/0.3	2CSB803001R3630	922209			0.400	1
4	30	63	DDA804AC-63/0.03	2CSB804001R1630	924401			0.460	1
	300	63	DDA804AC-63/0.3	2CSB804001R3630	924609			0.460	1

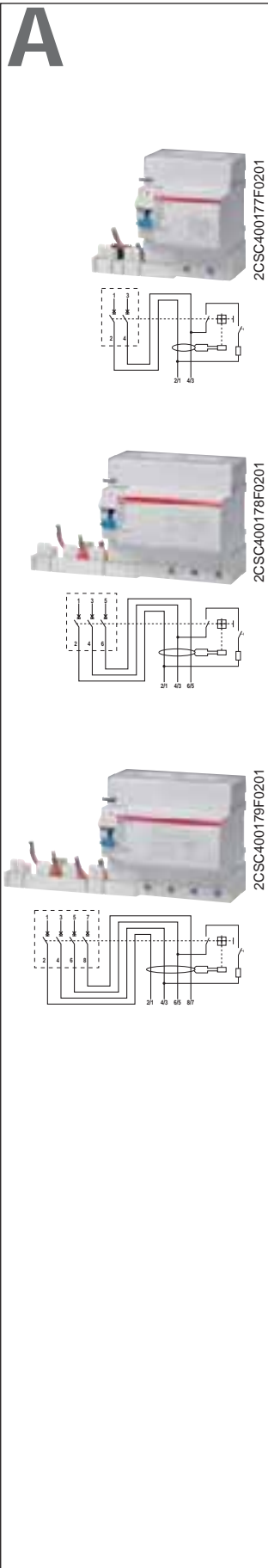

DDA 800 A type for MCBs S800

Function: RCD-block for assembly on site with MCBs S800 up to 63A. Protection against the effects of sinusoidal alternating and direct pulsating earth fault currents; protection against indirect contacts and additional protection against direct (with $I\Delta n=30$ mA) contacts.

Application: commercial, industrial.

Standard: IEC/EN 60947-2 Ann. B

Number of poles	Rated residual current $I\Delta n$ mA	Rated current I_n A	Order details	Order code	Bbn 8012542	Price 1 piece	Price group	Weight 1 piece kg	Pack unit pc.	
2	30	63	DDA802 A-63/0.03	2CSB802101R1630	920007			0.300	1	
		63	DDA802 A-63/0.3	2CSB802101R3630	920205			0.300	1	
	100	63	DDA802 A-100/0.3	2CSB802101R3000	545033			0.415	1	
		63	DDA802 A-63/0.5	2CSB802101R4630	920403			0.300	1	
	100	63	DDA802 A-100/0.5	2CSB802101R4000	542636			0.415	1	
		63	DDA803 A-63/0.03	2CSB803101R1630	922308			0.400	1	
3	30	63	DDA803 A-63/0.3	2CSB803101R3630	922506			0.400	1	
		63	DDA803 A-100/0.3	2CSB803101R3000	544135			0.640	1	
	100	63	DDA803 A-63/0.5	2CSB803101R4630	922704			0.400	1	
		63	DDA803 A-100/0.5	2CSB803101R4000	541738			0.640	1	
	4	30	63	DDA804 A-63/0.03	2CSB804101R1630	924807			0.460	1
			63	DDA804 A-63/0.3	2CSB804101R3630	925002			0.460	1
100		63	DDA804 A-100/0.3	2CSB804101R3000	547532			0.765	1	
		63	DDA804 A-63/0.5	2CSB804101R4630	925200			0.460	1	
100		63	DDA804 A-100/0.5	2CSB804101R4000	544937			0.765	1	

A



2CSC400177F0201

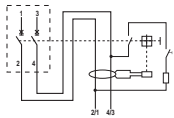

2CSC400178F0201

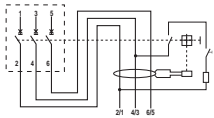

2CSC400179F0201

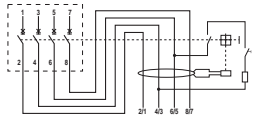

DDA 800 A AP-R type for MCBs S800

Function: RCD-block for assembly on site with MCBs S800 up to 63A. Protection against the effects of sinusoidal alternating and direct pulsating earth fault currents, providing the best compromise between safety and continuity in the service thanks to the resistance to unwanted trippings; protection against indirect contacts and additional protection against direct (with $I_{\Delta n}=30$ mA) contacts.

Application: commercial, industrial.

Standard: IEC/EN 60947-2 Ann. B

Number of poles	Rated residual current $I_{\Delta n}$ mA	Rated current I_n A	Order details		Bbn	Price	Price group	Weight	Pack unit
			Type code	Order code	8012542	1 piece	1 piece	1 piece	pc.
2	30	63	DDA802 A-63/0.03 AP-R	2CSB802401R1630	921400			0.300	1
		100	DDA802 A-100/0.03 AP-R	2CSB802401R1000	544630			0.415	1
3	30	63	DDA803 A-63/0.03 AP-R	2CSB803401R1630	923800			0.400	1
		100	DDA803 A-100/0.03 AP-R	2CSB803401R1000	542230			0.640	1
4	30	63	DDA804 A-63/0.03 AP-R	2CSB804401R1630	927709			0.460	1
		100	DDA804 A-100/0.03 AP-R	2CSB804401R1000	547136			0.765	1

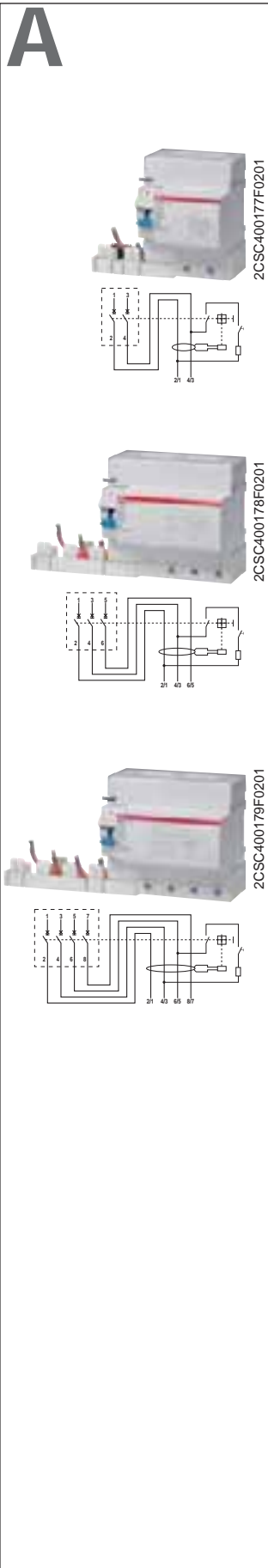

DDA 800 A selective type for MCBs S800

Function: RCD-block for assembly on site with MCBs S800 series up to 63A. Protection against the effects of sinusoidal alternating and direct pulsating earth fault currents with an intentional tripping delay, which permits to realize the selectivity with downstream instantaneous devices (for more information about selectivity see the technical guide).

Application: commercial, industrial.

Standard: IEC/EN 60947-2 Ann. B

Number of poles	Rated residual current	Rated current	Order details	Bbn 8012542	Price 1 piece	Price group	Weight 1 piece	Pack unit
	IΔn mA	In A	Type code	Order code	EAN		kg	pc.
2	300	63	DDA802 A S-63/0.3	2CSB802201R3630	920601		0.300	1
		100	DDA802 A S-100/0.3	2CSB802201R3000	542537		0.415	
	1000	63	DDA802 A S-63/1	2CSB802201R5630	920809		0.300	1
		100	DDA802 A S-100/1	2CSB802201R5000	547433		0.415	1
3	300	63	DDA803 A S-63/0.3	2CSB803201R3630	922902		0.400	1
		100	DDA803 A S-100/0.3	2CSB803201R3000	544838		0.640	1
	500	100	DDA803 A S-100/0.5	2CSB803201R4000	542438		0.640	1
		1000	63	DDA803 A S-63/1	2CSB803201R5630	923206		0.400
			100	DDA803 A S-100/1	2CSB803201R5000	547334		0.640
3	300	63	DDA804 A S-63/0.3	2CSB804201R3630	926207		0.460	1
		100	DDA804 A S-100/0.3	2CSB804201R3000	544739		0.765	1
	500	100	DDA804 A S-100/0.5	2CSB804201R4000	542339		0.765	1
		1000	63	DDA804 A S-63/1	2CSB804201R5630	547235		0.460
			100	DDA804 A S-100/1	2CSB804201R5000	547334		0.765

TECHNICAL CHARACTERISTICS			
Standards			
Electrical features	Operating characteristic: type (wave form of the earth leakage sensed)		
	Poles		
	Rated sensitivity $I_{\Delta n}$		A
	Rated current I_n		A
	Rated voltage U_e		V
	Insulation voltage U_i		V
	Max. operating voltage of circuit test		V
	Min. operating voltage of circuit test		V
	Rated frequency		Hz
	Short-circuit breaking capacity ultimate I_{cu}	240/415 V	kA
	acc. to IEC/EN 60947-2	254/440 V	kA
	(AC) 50/60 Hz	289/500 V	kA
	Short-circuit breaking capacity service I_{cs}	400/690 V	kA
	acc. to IEC/EN 60947-2	240/415 V	kA
	(AC) 50/60 Hz	254/440 V	kA
		289/500 V	kA
		400/690 V	kA
	Rated impulse withstand voltage (1.2/50) U_{imp}		kV
	Dielectric test voltage at ind. freq. for 1 min.		kV
	Thermomagnetic release characteristic	B: $3 I_n \leq I_m \leq 5 I_n$ C: $5 I_n \leq I_m \leq 10 I_n$ D: $10 I_n \leq I_m \leq 20 I_n$ K: $8 I_n \leq I_m \leq 14 I_n$	
Surge current resistance acc. to VDE 0432 Part 2 (wave 8/20)		A	
Mechanical features	Toggle		
	Electrical life		
	Mechanical life		
	Protection degree	housing terminals	
	Tropicalization acc. to IEC /EN 60068-2	humid heat	°C/RH
		constant climatic conditions	°C/RH
		variable climatic conditions	°C/RH
	Ambient temperature (with daily average $\leq + 35$ °C)		°C
Storage temperature		°C	
Installation	Terminal size for cables	flexible rigid	mm ² mm ²
	Tightening torque		N*m
	Mounting		
Dimensions and weight	Dimensions (H x D x W)	2P 3P 4P	mm mm mm
	Weight	2P	g
		3P	g
		4P	g
	Combination with auxiliary elements	Combinable with:	
auxiliary contact			
signal contact/auxiliary switch			
shunt trip undervoltage release			

(*) 1A on 2P and 4P versions, while 0.3A only on 4P ones.



3

DS800S A	DS800N A	DS800S A S	DS800N A S	DS800S A AP-R	DS800N A AP-R
IEC/EN 60947-2					
A		A		A	
2P, 3P, 4P		2P,4P		2P, 3P, 4P	
0.3		0.3-1(*)		0.03	
125					
230/400-240/415-400/690					
690					
690					
195					
50...60					
50	36	50	36	50	36
30	20	30	20	30	20
10	10	10	10	10	10
4.5	4.5	4.5	4.5	4.5	4.5
40	30	40	30	40	30
15	10	15	10	15	10
5	5	5	5	5	5
3	3	3	3	3	3
6					
2.5					
■ ■ ■ ■	■ ■ ■	■ ■ ■ ■	■ ■ ■	■ ■ ■ ■	■ ■ ■
250	250	5000	5000	3000	3000
black (MCB) sealable in ON-OFF position + blue (RCD) operating just from OFF position					
10000					
20000					
IP4X					
IP2X					
28 cycles with 55/95...100					
23/83 - 40/93 - 55/20					
25/95 - 40/95					
-25...+60					
-40...+70					
6...50					
6...70					
min. 3 / max. 4					
on DIN rail EN 60715 (35 mm) by means of rapid fixing device					
108,2 x 82,3 x 133.5					
108,2 x 82,3 x 196					
108,2 x 82,3 x 223					
790					
1140					
1440					
yes					
yes					
yes					
yes					

DS800S, A type

Function: protection against overload and short-circuit currents; protection against the effects of sinusoidal alternating earth fault currents; protection against indirect contacts; command and isolation of resistive and inductive loads.

Application: industrial.

Standard: IEC/EN 60947-2

Icu=50 kA

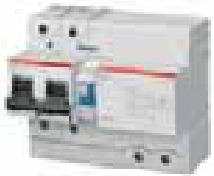

2CCA413257F0001

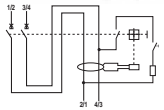

2CCA413258F0001

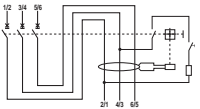

2CCA413259F0001

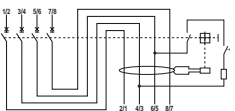

Number of poles	Curve	Rated residual current		Rated current		Order details	Bbn 7612271	Price 1 piece	Price group	Weight 1 piece	Pack unit
		I Δ n mA	In A	In A	Type code						
2	B	300	125	125		DS802S-B125/0.3A	2CCA862005R0845	211721		0.790	1
	C	300	125	125		DS802S-C125/0.3A	2CCA862005R0844	211738		0.790	1
	D	300	125	125		DS802S-D125/0.3A	2CCA862005R0841	211745		0.790	1
	K	300	125	125		DS802S-K125/0.3A	2CCA862005R0647	211752		0.790	1
3	B	300	125	125		DS803S-B125/0.3A	2CCA863005R0845	211769		1.14	1
	C	300	125	125		DS803S-C125/0.3A	2CCA863005R0844	211776		1.14	1
	D	300	125	125		DS803S-D125/0.3A	2CCA863005R0841	211783		1.14	1
	K	300	125	125		DS803S-K125/0.3A	2CCA863005R0647	211790		1.14	1
4	B	300	125	125		DS804S-B125/0.3A	2CCA864005R0845	211806		1.44	1
	C	300	125	125		DS804S-C125/0.3A	2CCA864005R0844	211813		1.44	1
	D	300	125	125		DS804S-D125/0.3A	2CCA864005R0841	211820		1.44	1
	K	300	125	125		DS804S-K125/0.3A	2CCA864005R0647	211837		1.44	1

DS800N, A type

Function: protection against overload and short-circuit currents; protection against the effects of sinusoidal alternating earth fault currents; protection against indirect contacts; command and isolation of resistive and inductive loads.

Application: industrial.

Standard: IEC/EN 60947-2

Icu=36 kA

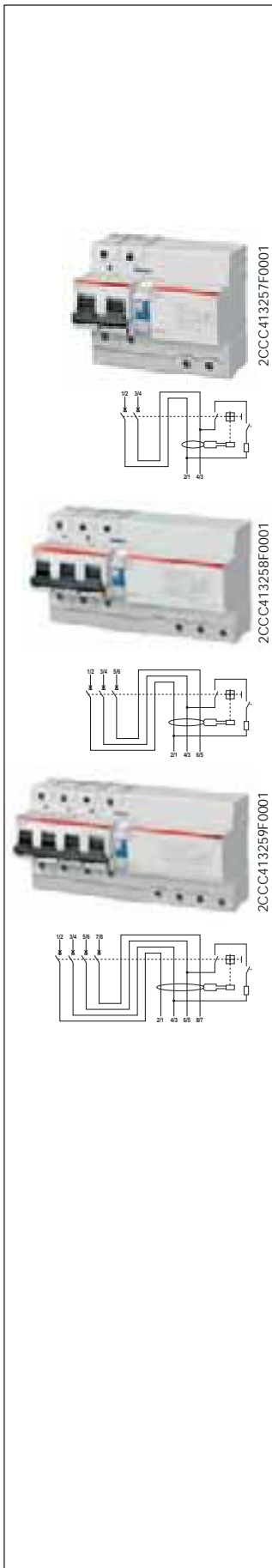

Number of poles	Curve	Rated residual current IΔn mA	Rated current In A	Order details Type code	Order code	Bbn 7612271	Price 1 piece	Price group	Weight 1 piece	Pack unit
2	B	300	125	DS802N-B125/0.3A	2CCA892005R0845	211844			0.790	1
	C	300	125	DS802N-C125/0.3A	2CCA892005R0844	211851			0.790	1
	D	300	125	DS802N-D125/0.3A	2CCA892005R0841	211868			0.790	1

3	B	300	125	DS803N-B125/0.3A	2CCA893005R0845	211875			1.14	1
	C	300	125	DS803N-C125/0.3A	2CCA893005R0844	211882			1.14	1
	D	300	125	DS803N-D125/0.3A	2CCA893005R0841	211899			1.14	1

4	B	300	125	DS804N-B125/0.3A	2CCA894005R0845	211905			1.44	1
	C	300	125	DS804N-C125/0.3A	2CCA894005R0844	211912			1.44	1
	D	300	125	DS804N-D125/0.3A	2CCA894005R0841	211929			1.44	1

3

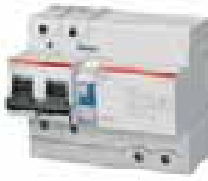

2CCC413257F0001

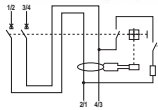

2CCC413259F0001

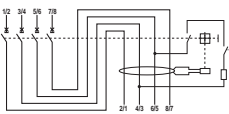

DS800S, A selective type

Function: protection against overload and short-circuit currents; protection against the effects of sinusoidal alternating earth fault currents with an intentional tripping delay, which allows to realize the selectivity with downstream instantaneous devices (for more information about selectivity see the technical guide); protection against indirect contacts; command and isolation of resistive and inductive loads.

Application: industrial.

Standard: IEC/EN 60947-2

Icu=50 kA

Number of poles	Curve	Rated residual current I _{Δn} mA	Rated current In A	Order details		Bbn 7612271	Price 1 piece	Price group	Weight 1 piece	Pack unit
				Type code	Order code	EAN			kg	pc.
2	B	1000	125	DS802S-B125/1AS	2CCC862006R0845	211516			0.790	1
	C	1000	125	DS802S-C125/1AS	2CCC862006R0844	211523			0.790	1
	D	1000	125	DS802S-D125/1AS	2CCC862006R0841	211530			0.790	1
	K	1000	125	DS802S-K125/1AS	2CCC862006R0647	211547			0.790	1
4	B	300	125	DS804S-B125/0.3AS	2CCC864005R0845	211554			1.44	1
		1000	125	DS804S-B125/1AS	2CCC864006R0845	211592			1.44	1
	C	300	125	DS804S-C125/0.3AS	2CCC864005R0844	211561			1.44	1
		1000	125	DS804S-C125/1AS	2CCC864006R0844	211608			1.44	1
	D	300	125	DS804S-D125/0.3AS	2CCC864005R0841	211578			1.44	1
		1000	125	DS804S-D125/1AS	2CCC864006R0841	211615			1.44	1
	K	300	125	DS804S-K125/0.3AS	2CCC864005R0647	211685			1.44	1
		1000	125	DS804S-K125/1AS	2CCC864006R0647	211622			1.44	1

DS800N, A selective type

Function: protection against overload and short-circuit currents; protection against the effects of sinusoidal alternating earth fault currents with an intentional tripping delay, which allows to realize the selectivity with downstream instantaneous devices (for more information about selectivity see the technical guide); protection against indirect contacts; command and isolation of resistive and inductive loads.

Application: industrial.

Standard: IEC/EN 60947-2

Icu=36 kA

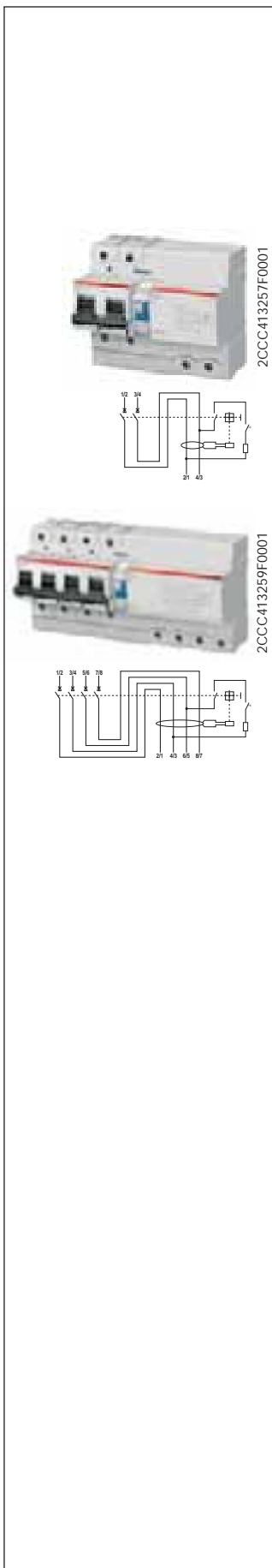

Number of poles	Curve	Rated residual current I Δ n mA	Rated current I _n A	Order details Type code	Order code	Bbn	Price	Price	Weight	Pack
						7612271	1 piece	group	1 piece	unit
						EAN			kg	pc.
2	B	1000	125	DS802N-B125/1AS	2CCC892006R0845	211639			0.790	1
	C	1000	125	DS802N-C125/1AS	2CCC892006R0844	211646			0.790	1
	D	1000	125	DS802N-D125/1AS	2CCC892006R0841	211653			0.790	1

4	B	300	125	DS804N-B125/0.3AS	2CCC894005R0845	211660			1.44	1
		1000	125	DS804N-B125/1AS	2CCC894006R0845	211691			1.44	1
C	300	125	DS804N-C125/0.3AS	2CCC894005R0844	211677			1.44	1	
	1000	125	DS804N-C125/1AS	2CCC894006R0844	211707			1.44	1	
D	300	125	DS804N-D125/0.3AS	2CCC894005R0841	211684			1.44	1	
	1000	125	DS804N-D125/1AS	2CCC894006R0841	211714			1.44	1	

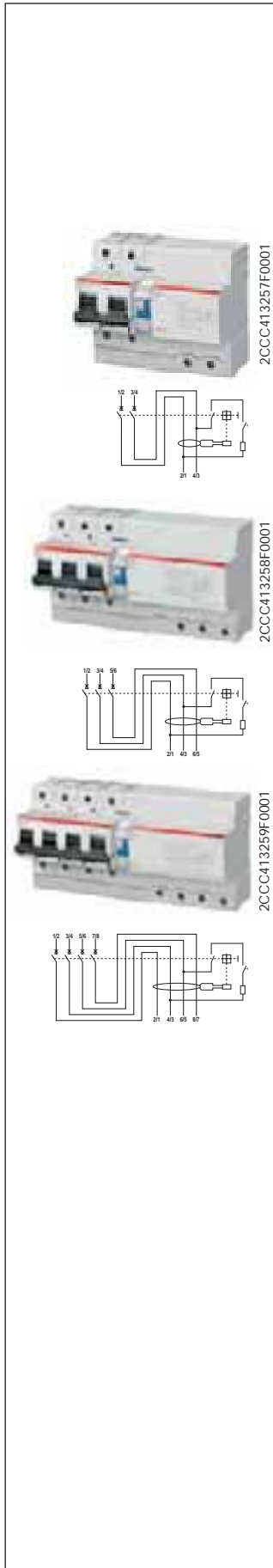

DS800S AP-R, A type

Function: protection against the effects of sinusoidal alternating earth fault currents, providing the best compromise between safety and continuity in the service thanks to the resistance to unwanted trippings; protection against indirect contacts and additional protection against direct ($I_{\Delta n}=30\text{mA}$) contacts; protection and isolation of resistive and inductive loads.

Application: industrial.

Standard: IEC/EN 60947-2

$I_{cu}=50\text{ kA}$

Number of poles	Curve	Rated residual current $I_{\Delta n}$ mA	Rated current I_n A	Order details Type code	Order code	Bbn	Price	Price	Weight	Pack
						7612271	1 piece	group	1 piece	unit
						EAN			kg	pc.
2	B	300	125	DS802SB125/.03AP-R	2CCB862004R0845	211301			0.790	1
	C	300	125	DS802SC125/.03AP-R	2CCB862004R0844	211318			0.790	1
	D	300	125	DS802SD125/.03AP-R	2CCB862004R0841	211325			0.790	1
	K	300	125	DS802SK125/.03AP-R	2CCB862004R0647	211332			0.790	1
3	B	300	125	DS803SB125/.03AP-R	2CCB863004R0845	211349			1.14	1
	C	300	125	DS803SC125/.03AP-R	2CCB863004R0844	211356			1.14	1
	D	300	125	DS803SD125/.03AP-R	2CCB863004R0841	211363			1.14	1
	K	300	125	DS803SK125/.03AP-R	2CCB863004R0647	211370			1.14	1
4	B	300	125	DS804SB125/.03AP-R	2CCB864004R0845	211387			1.44	1
	C	300	125	DS804SC125/.03AP-R	2CCB864004R0844	211394			1.44	1
	D	300	125	DS804SD125/.03AP-R	2CCB864004R0841	211400			1.44	1
	K	300	125	DS804SK125/.03AP-R	2CCB864004R0647	211417			1.44	1

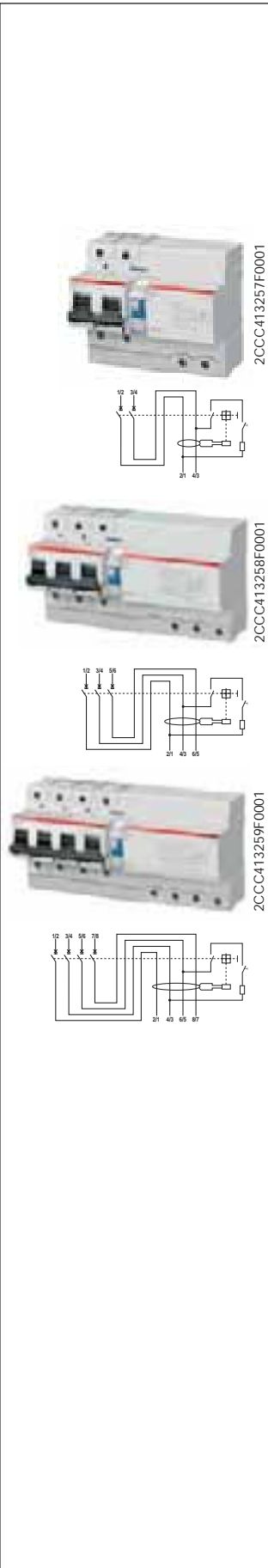

DS800N AP-R, A type

Function: protection against the effects of sinusoidal alternating earth fault currents, providing the best compromise between safety and continuity in the service thanks to the resistance to unwanted trippings; protection against indirect contacts and additional protection against direct ($I\Delta n=30\text{mA}$) contacts; protection and isolation of resistive and inductive loads.

Application: industrial.

Standard: IEC/EN 60947-2

$I_{cu}=36 \text{ kA}$

Number of poles	Curve	Rated residual current $I\Delta n$ mA	Rated current I_n A	Order details Type code	Order code	Bbn	Price	Price	Weight	Pack
						7612271	1 piece	group	1 piece	unit
						EAN			kg	pc.
2	B	300	125	DS802NB125/.03AP-R	2CCB892004R0845	211424			0.790	1
	C	300	125	DS802NC125/.03AP-R	2CCB892004R0844	211431			0.790	1
	D	300	125	DS802ND125/.03AP-R	2CCB892004R0841	211448			0.790	1

3	B	300	125	DS803NB125/.03AP-R	2CCB893004R0845	211455			1.14	1
	C	300	125	DS803NC125/.03AP-R	2CCB893004R0844	211462			1.14	1
	D	300	125	DS803ND125/.03AP-R	2CCB893004R0841	211479			1.14	1

4	B	300	125	DS804NB125/.03AP-R	2CCB894004R0845	211486			1.44	1
	C	300	125	DS804NC125/.03AP-R	2CCB894004R0844	211493			1.44	1
	D	300	125	DS804ND125/.03AP-R	2CCB894004R0841	211509			1.44	1



2CSC400263F0201



2CSC400189F0201



2CSC400187F0201

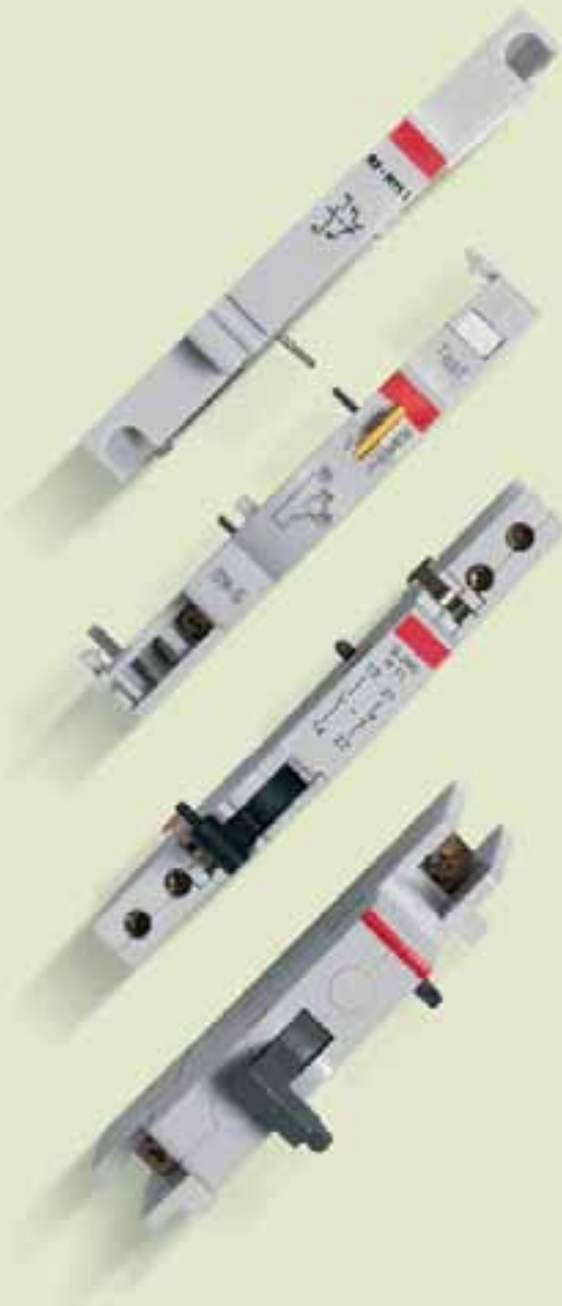

Index

Auxiliary elements and accessories for MCBs S 200 and RCDs F 200 and DS 200 series	4/2
Auxiliary elements and accessories for MCBs S 9.. and RCBOs DS 9.. series	4/28
Auxiliary elements and accessories for MCBs S 280, S 290 and S800 series and for RCD-blocks DDA 800	4/34

New System pro *M* compact range of auxiliary elements and accessories is universal: in fact it is suitable for MCBs S 200 range, for RCDs F 200 range and also for RCBOs DS 200 range and it is useful in terms of stock management.

The auxiliary elements range (composed by auxiliary and signal contacts, shunt trips, undervoltage releases and automatic reclosing units) is quite wide and there are different possible schemes for assemblage with devices. All these configurations are possible without the need of any dedicated auxiliary interface contact. Thus MCBs and RCDs performances are improved, even because innovative and integrated solutions can be used in every installation.

The connection accessories range (busbars, connection terminals, feeder terminals) allows any kind of wiring. The range of standard accessories (labels, covers) permits to customize the installation.



2CSC400258F0201



2CSC400263F0201

ABB Auxiliary elements and accessories for MCBs S 200 and RCDs F 200 and DS 200 series

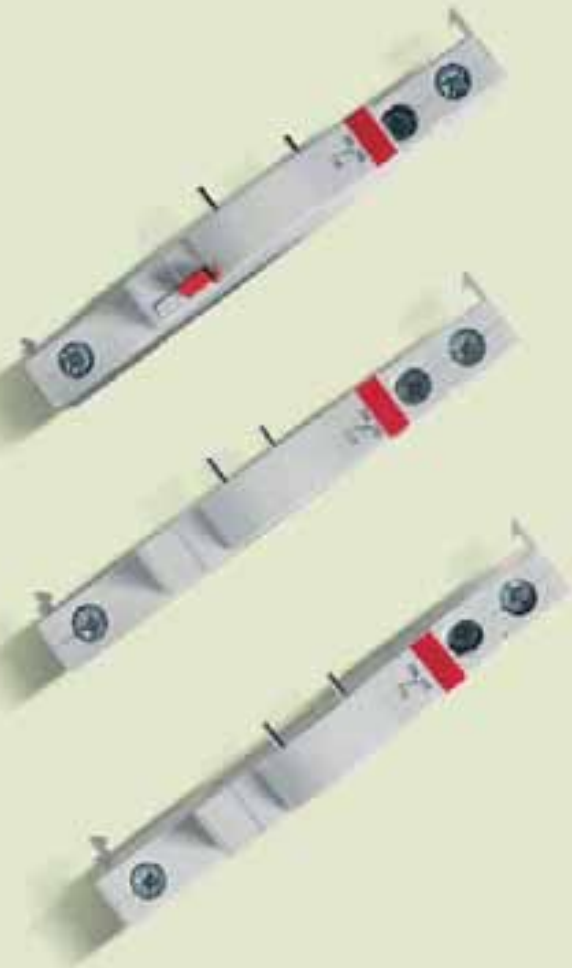

Index

Schemes for combination of auxiliary elements and S 200, F 200 and DS 200 series	4/4
Technical features of auxiliary elements and accessories for MCBs S 200 and RCDs F 200 and DS 200 series	4/5
Selection tables of auxiliary elements and accessories for MCBs S 200 and RCDs F 200 and DS 200 series	
Signal/auxiliary contacts.....	4/8
Auxiliary contacts.....	4/8
Bottom-fitting auxiliary contacts for S 200, S 200 M, S 200 P	4/8
Shunt trips	4/8
Undervoltage releases.....	4/9
Hand operated neutral.....	4/9
Accessories for S 200 U and S 200 UP.....	4/9
UL-approved busbar blocks	4/9
Mechanical tripping device	4/10
Plug-in base.....	4/10
Motor operating devices	4/10
Auto-reclosing units	4/10
Busbars	4/13
Other accessories.....	4/21

Combination between auxiliary elements and S 200, DDA 200 + S 200 or DS 200

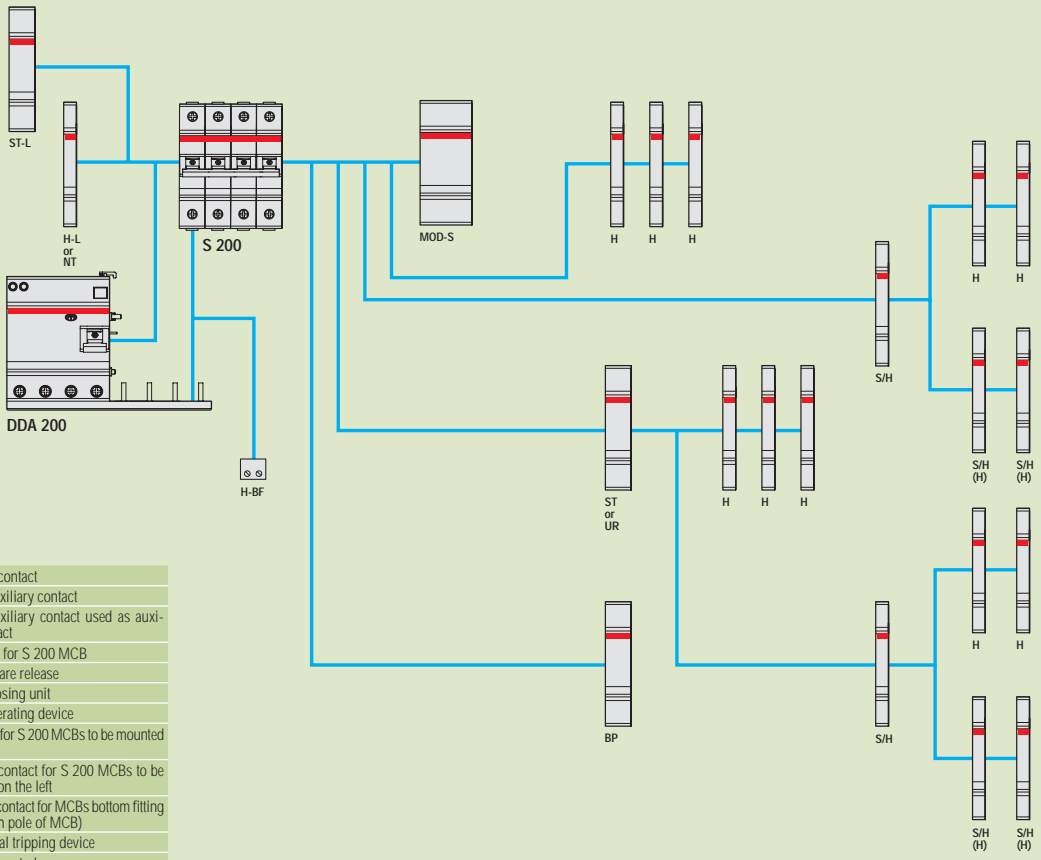

H	Auxiliary contact
S/H	Signal/Auxiliary contact
S/H (H)	Signal/Auxiliary contact used as auxiliary contact
ST	Shunt trip for S 200 MCB
UR	Undervoltage release
AR	Auto reclosing unit
MOD-S*	Motor operating device
ST-L	Shunt trip for S 200 MCBs to be mounted on the left
H-L	Auxiliary contact for S 200 MCBs to be mounted on the left
H-BF	Auxiliary contact for MCBs bottom fitting (1 for each pole of MCB)
BP	Mechanical tripping device
NT	Switched neutral

* in case of using S 200 coupled with DDA 200, MOD-S doesn't operate in case of earth-leakage fault

Combination between auxiliary elements and F 200

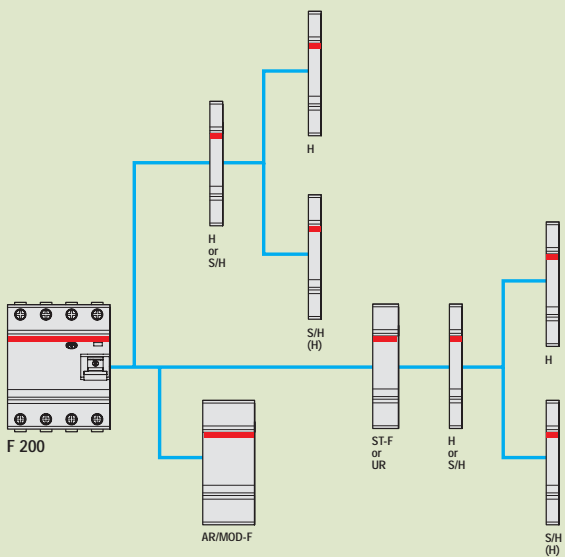

H	Auxiliary contact
S/H	Signal/Auxiliary contact
S/H (H)	Signal/Auxiliary contact used as auxiliary contact
UR	Undervoltage release
AR	Auto reclosing unit
MOD-F	Motor operating device
ST-F	Shunt trip for F 200 RCCB

Combination between auxiliary elements and F 200 125 A



H	Auxiliary contact
S/H	Signal/Auxiliary contact

System **pro M compact**® Technical features

Auxiliary elements and accessories for MCBs S 200 and RCDs F 200 and DS 200 series

Auxiliary contact and signal/auxiliary contact			S2C-H6R, S2C-H11L, S2C-H20, S2c-H02 and S2C-S/H6R
Rated current	A		10
Min. rated voltage UBmin	AC	V	24
	DC	V	24
Min. rated operational current/voltage			10 mA at 12 V; 5 mA at 24 V
Short-circuit withstand capacity	V		230 a.c. 100A with S201 K4
Overvoltage category			III
Surge voltage (1.2/50 ms)	kV		4
Connection cross section	mm ²		0.75...2.5 (up to 2 x 1.5 mm ² for S2C-H11L, S2C-H20L and S2C-H02L)
Tightening torque	Nm		1.2 (max. 0.8 for S2C-H11L, S2C-H20L and S2C-H02L)
Contact stability in vibration test according to DIN IEC 68-2-6			5g, 20 sweep cycles 5...150...5 Hz at 24 V AC/DC, 5 mA automatic reclosing < 10 ms
Mechanical service life			10000 operations
Dimensions (H x D x W)	mm		85 x 69 x 8.8

Bottom-fitting auxiliary contact			S 2C-H10 and S 2C-H01
Contact complement			1NO (1 make contact), 1NC (1 normally closed contact), leading make contact, late closing
Contact load			AC14 2 A/230 V - DC 12 identical DC13/DC13 1 A /50 V, 2 A/30 V
Min. rated voltage	V		12 AC/DC at 0.1 VA
Short-circuit withstand capacity			230 VAC 1000 A, fault protection with S 201-K2 or Z2
Electrical serviceable life			> 4000 switchover cycles
Standard			VDE 0106 Part 101
Connection cross-section	mm ²		0.75 to 2.5
Tightening torque	N*m		0.5

Signal auxiliary contact for F 200 125A and F 200 B			F2 125A-S/H
Rated current	AC	A	6
	DC	A	1
Min. rated voltage Ub min	AC	V	230
	DC	V	110
Connection cross section	mm ²		1...1.5
Tightening torque	Nm		0.8
Dimensions (H x D x W)	mm		85 x 69 x 8.8

Shunt trip for S 200 MCBs			S 2C-A1				S 2C-A2						
Rated voltage	AC	V	12...60				110...415						
	DC	V	12...60				110...250						
Max release duration		ms	<10				<10						
Min. release voltage	AC	V	7				55						
	DC	V	10				80						
Consumption on release	Ub	V	12 DC	12 AC	24 DC	24 AC	60 DC	60 AC	110 DC	110 AC	220 DC	230 AC	415 AC
	Ib max	A	2.2	2.5	4.5	5	14	8.8	0.35	0.5	1.1	1.0	2.7
Coil resistance		Ω	3.7				225						
Terminals		mm ²	16				16						
Tightening torque		Nm	2.5				2.5						
Dimensions (H x D x W)		mm	85 x 69 x 17.5				85 x 69 x 17.5						

Shunt trip for F 200 RCCBs			F 2C-A1				F 2C-A2			
Rated voltage	AC	V	12...60				110...415			
	DC	V	12...60				110...250			
Max release duration		ms	10				10			
Min. release voltage	AC	V	6				75			
	DC	V	4.5				55			
Consumption on release	Ub	V	12 DC	12 AC	60 DC	60 AC	110 DC	110 AC	250 DC	415 AC
	Ib max	VA	10.6	7.8	348	306	5.5	3.8	25	66.4
Coil resistance			5.5				150			
Terminals		mm ²	2x1.5				2x1.5			
Tightening torque		Nm	0.2				0.2			
Dimensions (H x D x W)		mm	85 x 69 x 17.5				85 x 69 x 17.5			

Undervoltage release			S2C-UA 12 DC	S2C-UA 24 AC	S2C-UA 24 DC	S2C-UA 48 AC	S2C-UA 48 DC	S2C-UA 110 AC	S2C-UA 110 DC	S2C-UA 230 AC	S2C-UA 230 DC	S2C-UA 400 AC
Standards			IEC/EN 60947-1									
Rated voltage	AC	V		24		48		110		230		400
	DC	V	12		24		48		110		230	
Frequency		Hz	50...60									
Release trip		V	0.35 Un ≥ V ≥ 0.7 Un									
Terminals		mm ²	2x1.5									
Consumption		VA	0.2	3.6	2	3.6	2.1	3.5	2.2	3.7	2.3	2.4
Resistance to corrosion		°C/RH	constant atmosphere: 23/83 - 40/93 - 55/20; variable atmosphere: 25/95 - 40/93									
Protection degree			IPXXB/IP2X									
Tightening torque		Nm	0.4									
Dimensions (H x D x W)		mm	85 x 69 x 17.5									

Hand operated neutral left side mounted			S2C-Nt									
Rated current		A	max. 40									
Terminal		mm ²	10; box terminal									
Tightening torque		Nm	1.2									
Dimensions (H x D x W)		mm	85 x 69 x 8.8									

Busbars			Busbars for S200 MCBs, F200 RCCBs, DDA200 RCD-blocks, DS200 RCBOs and FS201 RCBOs									
Specifications			DIN IEC/EN 60439-1									
Busbars material			SF-Cu F 244									
Insulating profile material			plastic temperature resistant ≥ 90°C flame-retardant, self extinguishing, dioxine and halogene-free									
Busbar cross section		mm ²	10 / 16									
Max. busbar current Is phase		A	63 / 80									
Max. current in branch Ie phase		A	100 / 130									
Max. operating voltage		V	440									
Rated surge voltage		kV	4									
Test surge voltage (1.2/50)		kV	6.02									
Short-circuit withstand capacity		kA	25									
Climatic resistance			constant climate L23/83; 40/92 55/20 according to DIN 50015 humid heat, 28 cycles (≥ IEC/EN 60068-2-30)									
Overvoltage category			III									

Motor operating devices			S2C-CM					F2C-CM				
Supply		V	12 ... 30 V a.c. +10% - 15% (50-60Hz); 12 ... 48 V d.c. +10% - 15%									
Power consumption during the operation	12Va.c.	VA						< 15				
	24Va.c.	VA						< 22				
	30Va.c.	VA						< 25				
	12 ... 48Vd.c.	VA						< 20				
Power consumption at rest		VA	< 1.5									
Make-time at ambient temperature		sec	< 1									
Opening time at ambient temperature		sec	< 0.5									
Number of operations			< 20.000									
Operating temperature		°C	- 25 ... + 55									
Cables length of control circuit		m	< 1500									
Cables cross-section		mm ²	< 2.5									
Signal contact (terminals 3 - 4 - 5)			1NA + 1NC (change-over contact) 5A (250V AC) (inductive-ohmic load)									
Current carrying capacity												
Auxiliary contact (terminals 6 - 7 - 8)			1NA + 1NC (change-over contact) 3A (250V AC) (inductive-ohmic load)									
Current carrying capacity												
Remote control*			By means of dry contacts									
Remote control terminals			Terminal 9 = make contact									
			Terminal 10 = opening contact									
			Terminal 11 = common reference for control contacts, +5V d.c. (supplied by the motor operating device)									

* Note:

1- After having powered the device, wait 5 seconds before activating the control functions.

2- In case of the device opening due to a fault, please wait 8 seconds before attempting to reclose the motor operator.

System **pro M compact®** Technical features

Auxiliary elements and accessories for MCBs S 200 and RCDs F 200 and DS 200 series

Auto-reclosing unit			F2C-ARI		F2C-ARI30	
Supply	V		12 ... 30 V a.c. +10% - 15% (50-60Hz); 12 ... 48 V d.c. +10% - 15%			
Number of automatic reset attempts			3			
Time of reset of the auto-reset meter	sec		16		45	
Power consumption during the operation	12Va.c.	VA	< 15			
	24Va.c.	VA	< 22			
	30Va.c.	VA	< 25			
	12 ... 48Vd.c.	VA	< 20			
Power consumption at rest	VA	< 1.5				
Waiting time between auto-reset attempts	sec		3		30	
Closing time at ambient temperature	sec		< 1			
Opening time at ambient temperature	sec		< 0.5			
Number of operations			< 20.000			
Operating temperature	°C		- 25 ... + 55			
Cables length of control circuit	m		< 1500			
Cables cross-section	mm ²		< 2.5			
Signaling contact to signal a locked state following three auto-reset attempts (terminals 3 – 4 – 5)			1NA + 1NC (change-over contact)			
Current carrying capacity			5A (250V AC) (ohmic load)			
Auxiliary contact (terminals 6 – 7 – 8)			1NA + 1NC (change-over contact)			
Current carrying capacity			3A (250V AC) (ohmic load)			
Remote control			By means of dry contacts			
Remote control terminals			Terminal 9 = closing and remote reset contact for locked state Terminal 10 = opening contact Terminal 11 = common reference for control contacts, +5V d.c. (supplied by the motor operating device)			

* After having powered the device, wait 5 seconds before activating the control functions.

Accessories for range S 200 U and S 200 UP acc. to UL 489/CSA-22.2 No.5

Auxiliary contact and signal contact			S2C-H6R U, S2C-S/6RU				
Rated current	A		10				
Min. rated voltage UBmin	AC	V	24				
	DC	V	24				
Min. rated operational current/voltage			10 mA at 12 V; 5 mA at 24 V				
Short-circuit withstand capacity	V		230 a.c. 100A with S201 K4				
Overvoltage category			III				
Surge voltage (1.2/50 ms)	kV		4				
Connection cross section	mm ²		0.75...2.5				
Tightening torque	Nm		1.2				
Contact stability in vibration test			5g, 20 sweep cycles 5...150...5 Hz according to DIN IEC 68-2-6 at 24 V AC/DC, 5 mA automatic reclosing < 10 ms				
Mechanical service life			10000 operations				
Dimensions (H x D x W)	mm		100 x 69 x 8.8				

Shunt trip			S 2C-A1 U						S 2C-A2 U				
Rated voltage	AC	V	12...60						110...415				
	DC	V	12...60						110...250				
Max release duration		ms	<10						<10				
Min. release voltage	AC	V	7						55				
	DC	V	10						80				
Consumption on release	Ub	V	12 DC	12 AC	24 DC	24 AC	60 DC	60 AC	110 DC	110 AC	220 DC	230 AC	415 AC
	Ib max	A	2.2	2.5	4.5	5	14	8.8	0.35	0.5	1.1	1.0	2.7
Coil resistance		Ω	3.7						225				
Terminals		mm ²	16						16				
Tightening torque		Nm	2						2				
Dimensions (H x D x W)		mm	100 x 69 x 17.5						100 x 69 x 17.5				



2CSC400465F0201

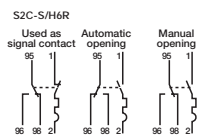

2CSC400324F0201

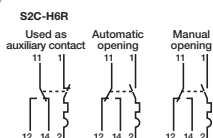

2CSC400155F0201



2CSC400471F0201

Signal/auxiliary contacts

Function S2C-S/H6R: choice through a selector between indication of the position of the device's contacts and signalling of the fault (overcurrent/short-circuit for MCBs and RCBOs; earth fault for RC-CBs and RCBOs). Suitable for MCBs S 200 series, RCCBs F 200 series, RCBOs DS 200 series.
Function S2C-H6R: indication of the position of the device's contacts. Suitable for MCBs S200 series. To be mounted on the left side of the MCBs thanks to the special pin. They are not suitable to be mounted together with RCD-block DDA200.

Description	Order details		Bbn 4016779	Price 1 piece	Price group	Weight 1 piece	Pack unit
	Type code	Order code					
Signal contact/ auxiliary switch	S 2C-S/H6R	2CDS200922R0001	563819			0.04	1
Auxiliary contact	S2C-H6R	2CDS200912R0001	56826			0.04	1

Auxiliary contacts

Description	Order details		Bbn 4016779	Price 1 piece	Price group	Weight 1 piece	Pack unit
	Type code	Order code					
Auxiliary contact 1 NO/1NC	S2C-H11L	2CDS200936R0001	648820			0.04	1
Auxiliary contact 2 NO	S2C-H20L	2CDS200936R0002	648837			0.04	1
Auxiliary contact 2 NC	S2C-H02L	2CDS200936R0003	648844			0.04	1

Bottom-fitting auxiliary contacts for S 200, S 200 M, S 200 P

1 NC	S 2C-H01	2CDS 200 970 R0001	64551 5			0.01	1
1 NO	S 2C-H10	2CDS 200 970 R0002	64552 2			0.01	1

packing unit 15 parts

1 NC	S 2C-H01 15x	2CDS 200 970 R0011	64677 2			0.01	15
1 NO	S 2C-H10 15x	2CDS 200 970 R0012	64681 9			0.01	15

Signal/auxiliary contact for F 200 125A and F 200 B

Function: choice through a selector between indication of the position of the device's contacts and signalling of the earth fault. Suitable for RCCBs F 200 125A and F 200 B series

Description	Order details		Bbn 4014712	Price 1 piece	Price group	Weight 1 piece	Pack unit
	Type code	Order code					
Signal/auxiliary contact	F2 125A-S/H	2CSS200922R0001	076983			0.04	1

Shunt trips

Function: remote opening of the device when a voltage is applied. Suitable for MCBs S 200 series and RCBOs DS 200 series.

Rated voltage	Order details		Bbn 8012542	Price 1 piece	Price group	Weight 1 piece	Pack unit
	Type code	Order code					
AC/DC 12...60 V	S 2C-A1	2CDS200909R0001	570992			0.15	1
AC 110...415 V/ DC110...250 V	S 2C-A2	2CDS200909R0002	571005			0.15	1

Function: remote opening of the device when a voltage is applied. Suitable for RCCBs F 200 series.

AC/DC 12...60V	F2C-A1	2CSS200933R0011	974901			0.15	1
AC 110...415V / DC 110...250V	F2C-A2	2CSS200933R0012	975007			0.15	1

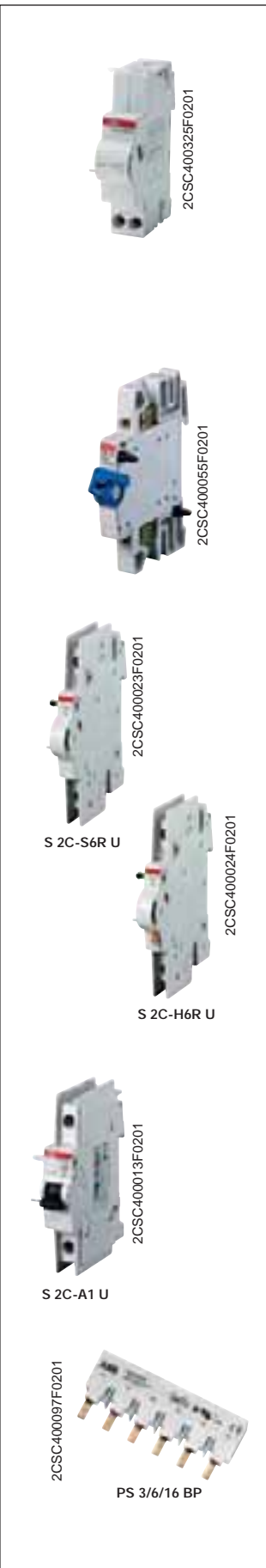

Undervoltage releases

Function: protection of the load in the event of a voltage drop (between 70% and 35% of its rated value); positive safety (device's tripping when the voltage is disconnected) emergency stop by means of a button. Suitable for MCBs S 200 series, RCBOs DS 200 series.

Rated voltage	Order details		Bbn 8012542	Price 1 piece	Price group	Weight 1 piece	Pack unit
	Type code	Order code	EAN			kg	pc.
12VDC	S2C-UA 12 DC	2CSS200911R0001	839705			0.09	1
24VAC	S2C-UA 24 AC	2CSS200911R0002	839804			0.09	1
24VDC	S2C-UA 24 DC	2CSS200911R0007	896401			0.09	1
48VAC	S2C-UA 48 AC	2CSS200911R0003	839903			0.09	1
48VDC	S2C-UA 48 DC	2CSS200911R0008	896500			0.09	1
110VAC	S2C-UA 110 AC	2CSS200911R0004	840008			0.09	1
110VDC	S2C-UA 110 DC	2CSS200911R0009	896609			0.09	1
230VAC	S2C-UA 230 AC	2CSS200911R0005	840107			0.09	1
230VDC	S2C-UA 230 DC	2CSS200911R0010	896708			0.09	1
400VAC	S2C-UA 400 AC	2CSS200911R0006	840206			0.09	1

Hand operated neutral

The hand operated neutral has to be mounted to the left side of the MCB and be snapped on the DIN rail. It is used for measuring duties where the neutral conductor must be in the open position. Due to the special design of the handle - when switching ON the MCB - the neutral will make before the MCB is closed.

The S2C - Nt is not to switch with a tool (screw driver).

Description	Order details		Bbn 4016779	Price 1 piece	Price group	Weight 1 piece	Pack unit
	Type code	Order code	EAN			kg	pc.
Max 40A	S2C-Nt	2CDS200918R0001	647625			0.06	1

Accessories for S 200 U and S 200 UP acc. UL 489 and CSA-22.2 No. 5

Auxiliary contact (switch)

only for range U and UP	S 2C-H6R U	2CDS 200 914 R0001	61561 7			0.035	1
-------------------------	------------	--------------------	---------	--	--	-------	---

Signal contact (bell alarm)

only for range U and UP	S 2C-S6R U	2CDS 200 924 R0001	64677 2			0.035	1
-------------------------	------------	--------------------	---------	--	--	-------	---

Shunt trip only for range U and UP

12 - 60 V AC/DC	S 2C-A1 U	2CDS 200 908 R0001	64472 3			0.15	1
110-415 V AC, 110-250V DC	S 2C-A2 U	2CDS 200 908 R0002	64473 0			0.15	1

Conn. capacity	Lenght	No. of poles	Order details		Bbn 4016779	CuNo 1 piece	Price 1 piece	Price group	Weight 1 piece	Pack unit
mm ²	mm		Type code	Order code	EAN				kg	pc.

UL-approved busbar blocks (not to be cut)

1 pole busbars, spacing 17.5 mm, UL 489

16	6	1	PS 1/6/16 BP	2CDL 210 489 R1606	64496 9	0.035			0.058	1
16	12	1	PS 1/12/16 BP	2CDL 210 489 R1612	64497 6	0.070			0.108	1
16	18	1	PS 1/18/16 BP	2CDL 210 489 R1618	64498 3	0.105			0.163	1



2 pole busbars, spacing 17.5 mm, UL 489

16	6	2	PS 2/6/16 BP	2CDL 220 489 R1606	64499 0	0.070	0.062	1
16	12	2	PS 2/12/16 BP	2CDL 220 489 R1612	64500 3	0.140	0.133	1
16	18	2	PS 2/18/16 BP	2CDL 220 489 R1618	64501 0	0.210	0.203	1

3 pole busbars, spacing 17.5 mm, UL 489

16	6	3	PS 3/6/16 BP	2CDL 230 489 R1606	64502 7	0.110	0.066	1
16	12	3	PS 3/12/16 BP	2CDL 230 489 R1612	64503 4	0.221	0.152	1
16	18	3	PS 3/18/16 BP	2CDL 230 489 R1618	64504 1	0.332	0.237	1

Mechanical tripping device

Function: it causes the automatic tripping of the circuit-breakers which it is associated to, when the panel or the door of the electrical switchboard are opened or removed.
Suitable for MCBs S 200 series (on both sides of the devices) and for DS 200 (only on the right side, because on the left side there's RCD-block DDA 200).

Description	Order details	Bbn	Price	Price	Weight	Pack
Type code	Order code	8012542	1 piece	group	1 piece	unit
		EAN			kg	pc.
Mechanical tripping device	S2C-BP	2CSS200998R0001	940203		0.048	1

Plug-in base

Function: it is possible to transform a standard circuit-breaker of the S 200 and F 200 range in a plug-in device which can be pulled out of the circuit where it is installed in one operation.
Suitable for MCBs S 200 series and for RCCBs F 200 series up to 63A.

Plug-in base	S2C-EST	2CSS200999R0001	940708		0.115	1
--------------	---------	-----------------	--------	--	-------	---

Motor operating devices

Function: S2C-CM and F2C-CM allow the remote control (opening or closing) of the coupled device.
Suitable for S 200 MCBs and F 200 RCCBs.

Motor operating device for 1P S200 MCBs	S2C-CM1	2CSS201997R0013	026259		0,166	1
Motor operating device for 2P and 3P S200 MCBs	S2C-CM2/3	2CSS203997R0013	026358		0,166	1
Motor operating device for 4P S200 MCBs	S2C-CM4	2CSS204997R0013	026457		0,166	1
Motor operating device for 2P and 4P F200 RCCBs	F2C-CM	2CSF200997R0013	026556		0,166	1

Auto-reclosing units

Function: F2C-ARI and F2C-ARI30 allow the auto-reclosing of the coupled device in case of unwanted tripping. Suitable for F 200 RCCBs.

Auto-reclosing unit for 2P and 4P F200 RCCBs	F2C-ARI	2CSF200996R0013	026655		0,166	1
Auto-reclosing unit for 2P and 4P F200 RCCBs (30")	F2C-ARI30	2CSF200995R0013	064350		0,166	1

System Selection tables Auxiliary elements for MCBs S 200 S 200, F 200 and and RCDs F 200 and DS 200 series DS 200 series

Example of application in low voltage 12...30 V a.c., 12...48 V d.c.

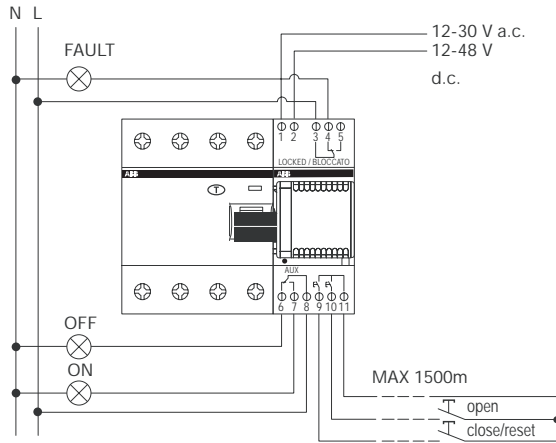

Example of application at 230 V a.c. by using a transformer TM15/12

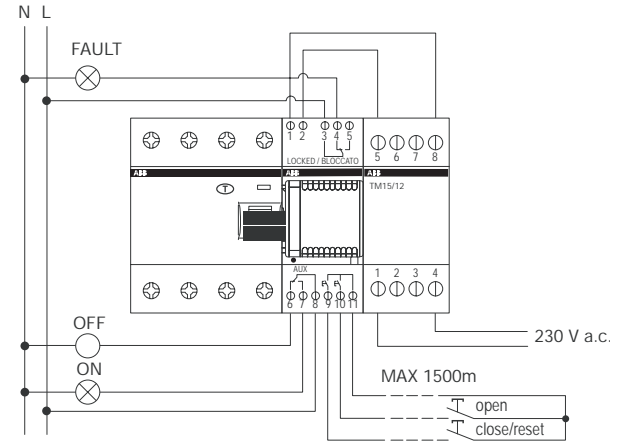

Example of application of more auto-reclosing units in low voltage 12...30 V a.c., 12...48 V d.c.

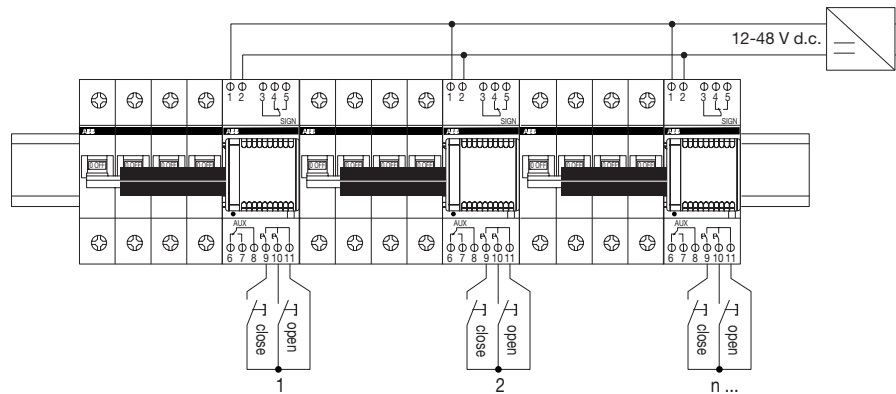

Example of application of more motor operating devices at 230 V a.c. by using only one transformer

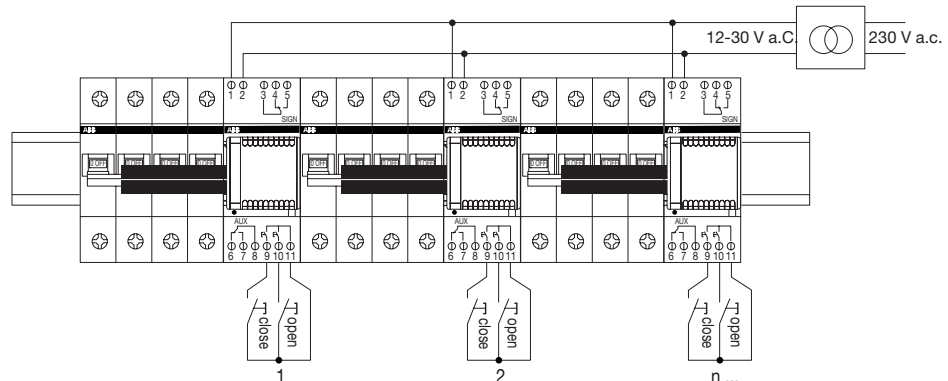

Example of application in low voltage 12...30 V a.c., 12...48 V d.c.

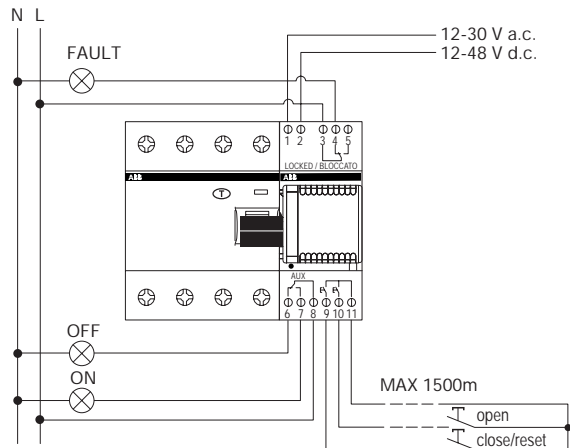

Example of application at 230 V a.c. by using a transformer TM15/12

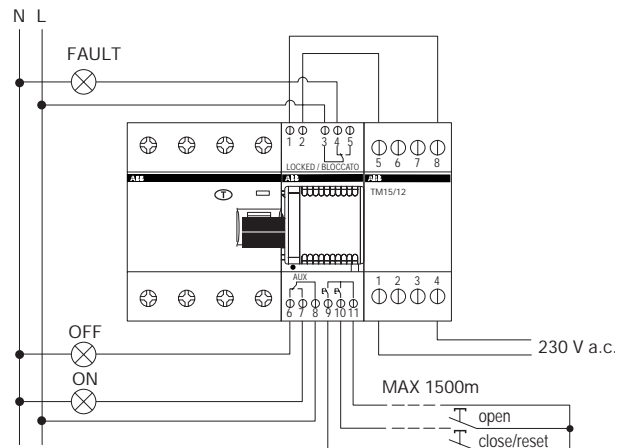

Example of application of more auto-reclosing units in low voltage 12...30 V a.c., 12...48 V d.c.

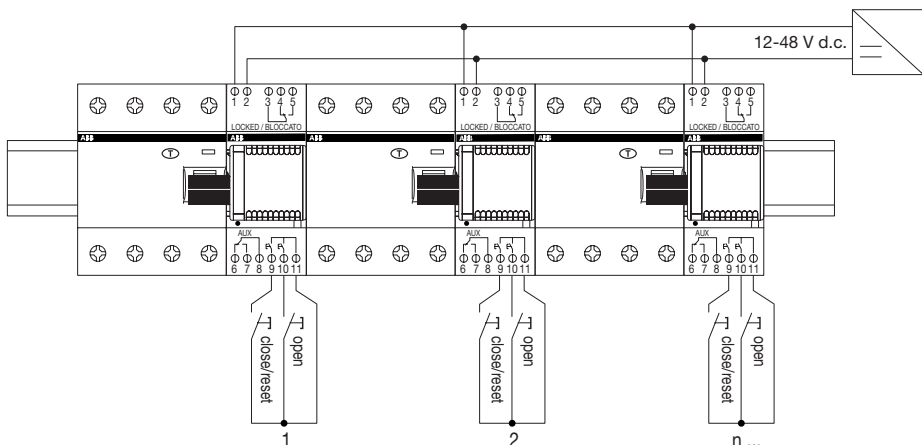

Example of application of more motor operating devices at 230 V a.c. by using only one transformer

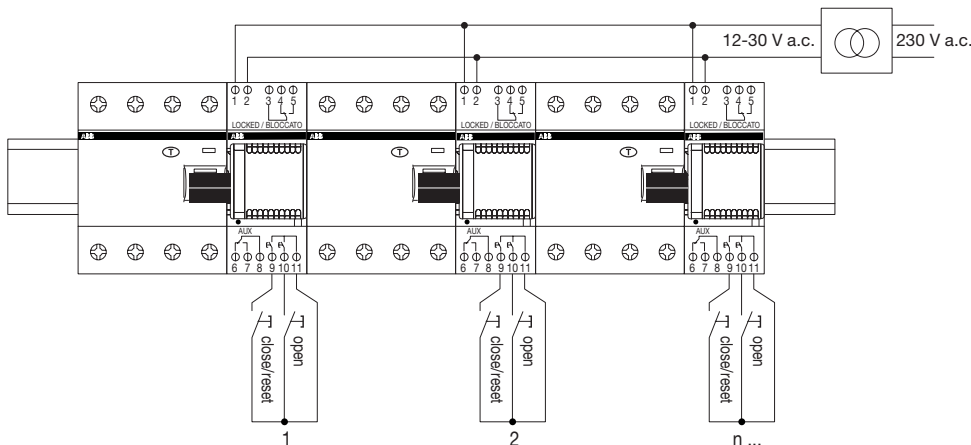

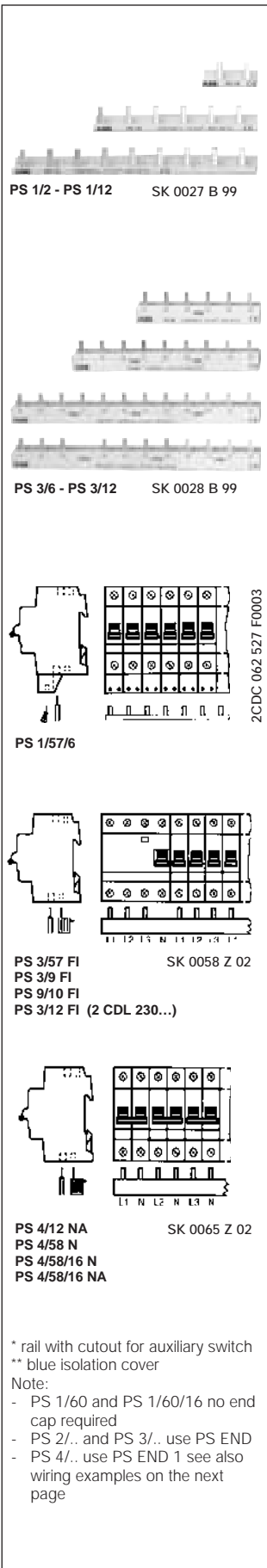

No. of pins	Phases	mm ²	Order details	Bbn	Price	Price	Cu-No.	Weight	Pack
			Type code	Order code	4016779	1 piece	group	1 piece	unit
					EAN		kg	kg	pc.

Pre-assembled busbars (not to be cut)

1-phase busbars, pin distance 17.6 mm, end caps PS-END 0

2	1	10	PS1/2	2CDL 210 001 R1002	463003		0.01	0.01	180
3	1	10	PS1/3	2CDL 210 001 R1003	514651		0.03	0.03	120
4	1	10	PS1/4	2CDL 210 001 R1004	648233		0.03	0.03	100
6	1	10	PS1/6	2CDL 210 001 R1006	463102		0.03	0.03	60
9	1	10	PS1/9	2CDL 210 001 R1009	463201		0.04	0.04	30
12	1	10	PS1/12	2CDL 210 001 R1012	463300		0.05	0.05	30

3-phase busbars, pin distance 17.6 mm

6	3	10	PS3/6	2CDL 231 001 R1006	463409		0.04	0.04	60
9	3	10	PS3/9	2CDL 231 001 R1009	463508		0.07	0.07	30
12	3	10	PS3/12	2CDL 231 001 R1012	463607		0.10	0.10	30
12	3	10	PS3/12FI	2CDL 231 002 R1012	463706		0.10	0.09	50

Busbars suitable for cutting

1-phase busbars, pin distance 17.6 mm, end caps PS-END 0

60	1	10	PS1/60	2CDL 210 001 R1060	514668		0.26	0.26	20
60	1	16	PS1/60/16	2CDL 210 001 R1660	516655		0.41	0.41	20

1-phase busbars, connection of 1-pole devices with auxiliary, end caps PS-END 0

38	1	10	PS1/38H	2CDL 210 001 R1038	586139		0.27	0.27	30
38	1	16	PS1/38/16H	2CDL 210 001 R1638	586146		0.45	0.45	30

1-phase busbars, connection of neutral (blue insulation), end caps END 1.1

28	1	10	PS1/28N	2CDL 210 001 R1028	629546		0.24	0.14	50
28	1	16	PS1/28/16N	2CDL 210 001 R1628	629560		0.32	0.20	50
57	1	10	PS1/57NA	2CDL 210 011 R1057	579728		0.24	0.14	50
57	1	10	PS1/57N	2CDL 210 001 R1057	629539		0.24	0.14	50
57	1	16	PS1/57/16NA	2CDL 210 011 R1657	579735		0.32	0.20	50
57	1	16	PS1/57/16N	2CDL 210 001 R1657	629553		0.32	0.20	50

1-phase busbars, connection of auxiliaries, end caps END 1.1 except PS 1/57/6

23	1	6	PS1/23/6	2CDL 210 005 R0623	584739		0.16	0.09	50
29	1	6	PS1/29/6	2CDL 210 005 R0629	580823		0.14	0.10	50
38	1	6	PS1/38/6	2CDL 210 005 R0638	580816		0.14	0.09	50
57	1	6	PS1/57/6	2CDL 210 005 R0657	585309		0.11	0.08	50

2-phase busbars, pin distance 17.6 mm, end caps PS-END

12	2	10	PS2/12	2CDL 220 001 R1012	556521		0.07	0.08	50
12	2	10	PS2/12A	2CDL 220 010 R1012	584616		0.07	0.08	50
12	2	16	PS2/12/16	2CDL 220 001 R1612	646918		0.11	0.09	50
58	2	10	PS2/58	2CDL 220 001 R1058	556552		0.32	0.36	10
58	2	16	PS2/58/16	2CDL 220 001 R1658	556569		0.55	0.49	10
58	2	16	PS2/58/16A	2CDL 220 010 R1658	584746		0.55	0.49	10

Note: PS...A is a busbar with removable pin

No. of pins	Phases	mm ²	Order details		Bbn 4016779	Price 1 piece	Price group	Cu-No.	Weight 1 piece	Pack unit
			Type code	Order code	EAN			kg	kg	pc.

2-phase busbars, connection of 2-pole devices with auxiliary, end caps PS-END

48	2	10	PS2/48H	2CDL 220 001 R1048	556538			0.47	0.35	10
48	2	16	PS2/48/16H	2CDL 220 001 R1648	556545			0.68	0.48	10
48	2	16	PS2/48/16HA	2CDL 220 012 R1648	584630			0.68	0.48	10

3-phase busbars, pin distance 17.6 mm, end caps PS-END

12	3	10	PS3/12	2CDL 230 001 R1012	576116			0.09	0.09	50
12	3	10	PS3/12A	2CDL 230 010 R1012	584647			0.09	0.09	50
12	3	16	PS3/12/16	2CDL 230 001 R1612	562805			0.16	0.12	50
60	3	10	PS3/60	2CDL 230 001 R1060	514699			0.51	0.47	10
60	3	10	PS3/60A	2CDL 230 010 R1060	563758			0.51	0.47	10
60	3	16	PS3/60/16	2CDL 230 001 R1660	514705			0.76	0.65	10
60	3	16	PS3/60/16A	2CDL 230 010 R1660	563765			0.76	0.65	10

3-phase busbars, connection of 1-pole devices with auxiliary, end caps PS-END

39	3	10	PS3/39H	2CDL 230 001 R1039	556590			0.51	0.43	10
39	3	16	PS3/39/16H	2CDL 230 001 R1639	556606			0.76	0.60	10

3-phase busbars, connection of 2-pole devices with auxiliary, end caps PS-END

24	3	10	PS3/24H	2CDL 230 001 R1024	556576			0.80	0.41	10
----	---	----	---------	--------------------	--------	--	--	------	------	----

3-phase busbars, connection of 3-pole devices with auxiliary, end caps PS-END

48	3	10	PS3/48H	2CDL 230 001 R1048	556613			0.51	0.43	10
48	3	16	PS3/48/16H	2CDL 230 001 R1648	556644			0.76	0.60	10
48	3	16	PS3/48/16HA	2CDL 230 012 R1648	584654			0.76	0.60	10

3-phase busbars, connection of 1+N or RCBOs, end caps PS-END

30	3	10	PS3/30	2CDL 230 001 R1030	556583			0.50	0.42	10
----	---	----	--------	--------------------	--------	--	--	------	------	----

3-phase busbars, N of the RCD omitted, end caps PS-END

9	3	10	PS3/9FI	2CDL 230 002 R1009	517515			0.10	0.06	50
10	3	10	PS3/10FI	2CDL 230 002 R1010	517522			0.10	0.07	50
12	3	10	PS3/12FI	2CDL 230 002 R1012	571074			0.11	0.09	50
57	3	10	PS3/57FI	2CDL 230 002 R1057	556651			0.55	0.46	10

3-phase busbars, N of the RCD omitted, with auxiliary at RCD. end caps PS-END

12	3	10	PS3/12FIH	2CDL 230 003 R1012	571081			0.11	0.09	50
----	---	----	-----------	--------------------	--------	--	--	------	------	----

4-phase busbars, pin distance 17.6 mm, end caps PS-END 1

12	4	10	PS4/12	2CDL 240 001 R1012	556668			0.12	0.11	30
12	4	10	PS4/12A	2CDL 240 010 R1012	584678			0.12	0.11	30
12	4	16	PS4/12/16	2CDL 240 001 R1612	556675			0.24	0.16	30
60	4	10	PS4/60	2CDL 240 001 R1060	556682			0.80	0.64	10
60	4	16	PS4/60/16	2CDL 240 001 R1660	556743			1.21	0.89	10
60	4	16	PS4/60/16A	2CDL 240 010 R1660	584685			1.21	0.89	10

Note: PS...A is a busbar with removable pin

4-phase busbars, connection of 4-pole devices with auxiliary, end caps PS-END 1

52	4	16	PS4/52/16H	2CDL 240 001 R1652	556699	1.30	0.78	10
52	4	16	PS4/52/16HA	2CDL 240 012 R1652	584692	1.30	0.78	10

4-phase busbars, connection of 1+N or RCBOs, end caps PS-END 1

12	4	10	PS4/12NA	2CDL 240 013 R1012	584708	0.14	0.10	30
58	4	10	PS4/58N	2CDL 240 001 R1058	556705	0.80	0.59	10
58	4	16	PS4/58/16N	2CDL 240 001 R1658	556736	1.21	0.77	10
58	4	16	PS4/58/16NA	2CDL 240 013 R1658	584715	1.21	0.77	10

4-phase busbars, connection of 1+N or RCBOs with auxiliary, end caps PS-END 1

48	4	16	PS4/48/16NHA	2CDL 240 014 R1648	584722	1.48	0.76	10
----	---	----	--------------	--------------------	--------	------	------	----

4-phase busbars, connection of 4-pole RCD with 1+N , end caps PS-END 1

58	4	10	PS4/58NNA	2CDL 240 010 R1058	563734	0.80	0.58	10
58	4	16	PS4/58/16NNA	2CDL 240 010 R1658	563741	1.21	0.80	10

Pre-assembled busbars (not to be cut) UL 489

1-phase busbars, pin distance 17.6 mm, UL 489

6	1	16	PS 1/6/16 BP	2CDL 210 489 R1606	644969	0.04	0.05	1
12	1	16	PS 1/12/16 BP	2CDL 210 489 R1612	644976	0.07	0.11	1
18	1	16	PS 1/18/16 BP	2CDL 210 489 R1618	644983	0.11	0.16	1

2-phase busbars, pin distance 17.6 mm, UL489

6	2	16	PS 2/6/16 BP	2CDL 220 489 R1606	644990	0.07	0.06	1
12	2	16	PS 2/12/16 BP	2CDL 220 489 R1612	645003	0.14	0.13	1
18	2	16	PS 2/18/16 BP	2CDL 220 489 R1618	645010	0.21	0.20	1

3-phase busbars. pin distance 17.6 mm. UL 489

6	3	16	PS 3/6/16 BP	2CDL 230 489 R1606	645027	0.11	0.07	1
12	3	16	PS 3/12/16 BP	2CDL 230 489 R1612	645034	0.22	0.15	1
18	3	16	PS 3/18/16 BP	2CDL 230 489 R1618	645041	0.33	0.24	1

Busbars (suitable for cutting) UL 1077

1-phase busbars, pin distance 17.6 mm, end caps PS-END 0

60	1	10	PS 1/60	2CDL 210 001 R1060	514668	0.26	0.26	20
60	1	16	PS 1/60/16	2CDL 210 001 R1660	516655	0.41	0.41	20

1-phase busbars, connection of 1-pole devices with auxiliary, PS-END 0

38	1	10	PS 1/38H	2CDL 210 001 R1038	586139	0.27	0.27	30
38	1	16	PS 1/38/16H	2CDL 210 001 R1638	586146	0.45	0.45	30

2-phase busbars, pin distance 17.6 mm, end caps PS-END SP

58	2	10	PS 2/58 SP	2CDL 220 111 R1058	646413	0.42		10
58	2	16	PS 2/58/16 SP	2CDL 220 111 R1658	646420	0.69		10

Note: PS...A is a busbar with removable pin



PS3/6/16 BP

2CSC400097F0201

No. of pins	Phases	mm ²	Order details	Order code	Bbn 4016779 EAN	Price 1 piece	Price group	Cu-No.	Weight 1 piece	Pack unit
			Type code					kg	kg	pc.

2-phase busbars, connection of 2-pole devices with auxiliary, end caps PS-END SP

48	2	16	PS 2/48/16 SP	2CDL 220 112 R1648	646437			0.68		10
----	---	----	---------------	--------------------	--------	--	--	------	--	----

3-phase busbars, pin distance 17.6 mm, end caps PS-END SP

60	3	10	PS 3/60 SP	2CDL 230 111 R1060	646444			0.68		10
60	3	16	PS 3/60/16 SP	2CDL 230 111 R1660	646451			1.02		10

3-phase busbars, connection of 3-pole devices with auxiliary, end caps PS-END SP

48	3	16	PS 3/48/16 SP	2CDL 230 112 R1648	646468			1.16		10
----	---	----	---------------	--------------------	--------	--	--	------	--	----

4-phase busbars, pin distance 17.6 mm, PS-END 1 SP

60	4	16	PS 4/60/16 SP	2CDL 240 111 R1660	646475			1.97		10
----	---	----	---------------	--------------------	--------	--	--	------	--	----

4-phase busbars, connection of 4-pole devices with auxiliary, end caps PS-END 1 SP

52	4	16	PS 4/52/16 SP	2CDL 240 112 R1652	646482			1.90		10
----	---	----	---------------	--------------------	--------	--	--	------	--	----

4-phase busbars, connection of 1+N and RCBO, end caps PS-END 1 SP

58	4	16	PS4/58/16N SP	2CDL 240 113 R1658	646499			1.86		10
----	---	----	---------------	--------------------	--------	--	--	------	--	----

Busbars (suitable for cutting) for DDA 200 and DS 200

3-phase busbars, connection of DDA 202 and DS 202, end caps PS-END

30	3	10	PS 3/30-DDA 202	2CDL 230 202 R1030	647472			0.97	0.41	10
30	3	16	PS 3/30/16-DDA 202	2CDL 230 202 R1630	647502			1.46	0.55	10

3-phase busbars, connection of DDA 202 and DS 202 with auxiliary, end caps PS-END

26	3	16	PS 3/26/16H-DDA 202		2CDL 230 202 R1626					648912
----	---	----	---------------------	--	--------------------	--	--	--	--	--------

4-phase busbars, connection of DDA 204 63 A and DS 204 50 A and 63 A, end caps PS-END 1

32	4	10	PS 4/32-DDA 204	2CDL 240 204 R1032	647458			1.41	0.56	10
32	4	16	PS 4/32/16-DDA 204	2CDL 240 204 R1632	647465			2.12	0.77	10

A = breakable pins

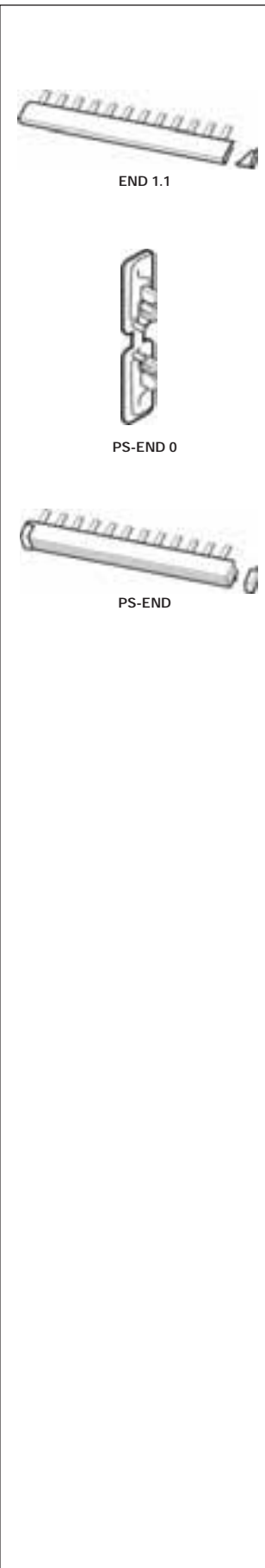

Conn. capacity mm ²	Module	Phases	Order details Type code	Order code	Bbn 4016779 EAN	Price 1 piece	Price group	Weight 1 piece kg	Pack unit pc.
--------------------------------	--------	--------	-------------------------	------------	-----------------	---------------	-------------	-------------------	---------------

End caps

			END 1.1	2CDL 200 011 R0011	638913			0.001	50
			PS-END 0	2CDL 200 001 R0004	652261			0.001	50
			PS-END	2CDL 200 001 R0001	514729			0.001	50
			PS-END 1	2CDL 200 001 R0002	570114			0.001	50
			PS-END SP	2CDL 200 110 R0001	646505			0.001	50
			PS-END 1 SP	2CDL 200 110 R0002	646512			0.001	50

Main circuit breaker busbar

3-phase busbar (10 mm²) for connecting main circuit breaker E 463/3-KB and pro M compact devices incl. end caps. No. of poles: 12 (1 x E 463/3-KB + 9 x S 201)

12	3	PS 3/12 E463	2CDL230004R1012	51741 6				0.220	30
----	---	--------------	-----------------	---------	--	--	--	-------	----

Loads depending on supply point and required connection capacity

End feeding

cross section/mm ²	comb and oblong-hole busbars (type KS)					busbar blocks (type PS/PSB)		
	10	12	20	24	36	10	16	
max. supply current I _s /phase	A	63	65	90	100	130*	63	80

* If fed via the terminals, always ensure that the following values are not exceeded, irrespective of the current carrying capacity (I_c) of the busbar:
For S 200 and S 200M series: max. 110 A.
For S 280 series: max. 140 A.

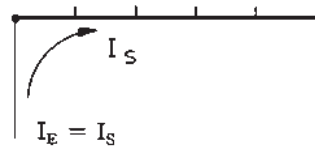

Non-end feeding (center or elsewhere on the rail)

cross section/mm ²	comb and oblong-hole busbars (KS-type)					busbar blocks (type PS/PSB)		
	10	12	20	24	36	10	16	
max. current in branch I _b /phase	A	100	110	150*	170*	220*	100	120*
max. supply current I _s /phase	A	depends on cross section						

* If fed via the terminals, always ensure that the following values are not exceeded, irrespective of the current carrying capacity (I_c) of the busbar:
For S 200 and S 200M series: max. 110 A.
For S 280 series: max. 140 A.

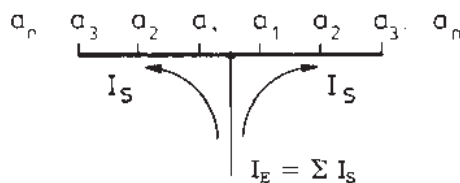

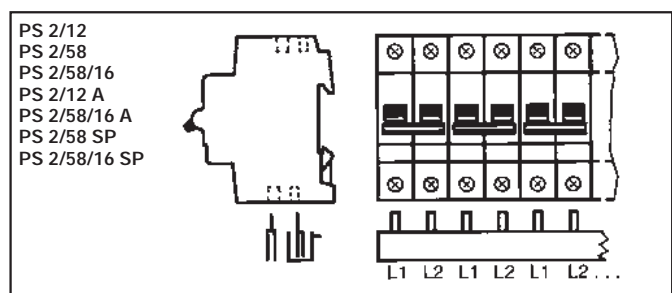
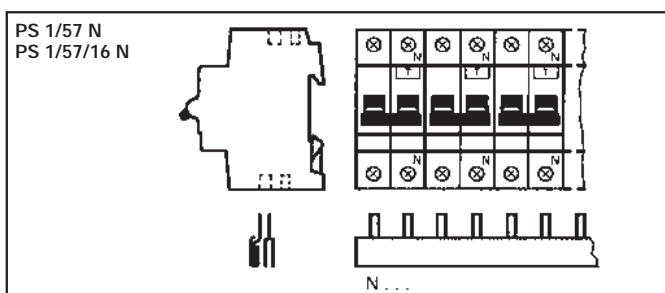
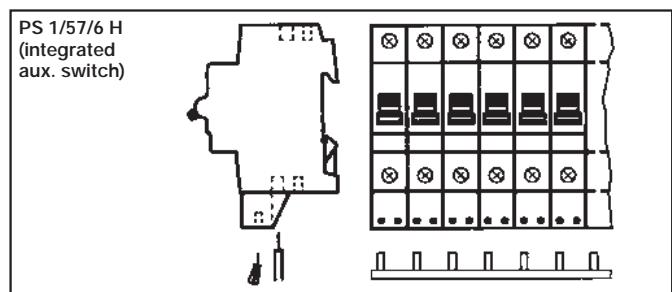
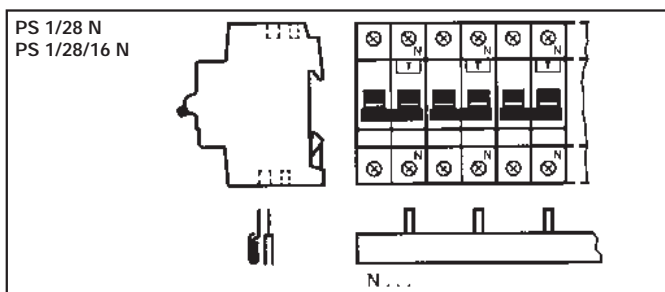
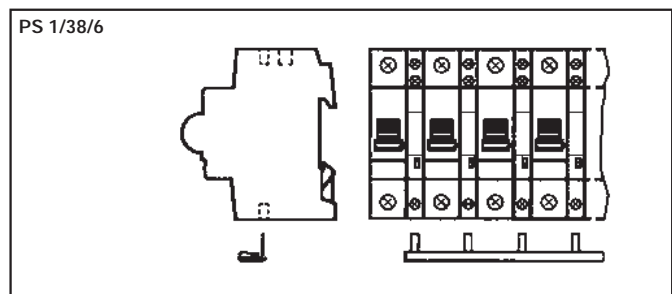
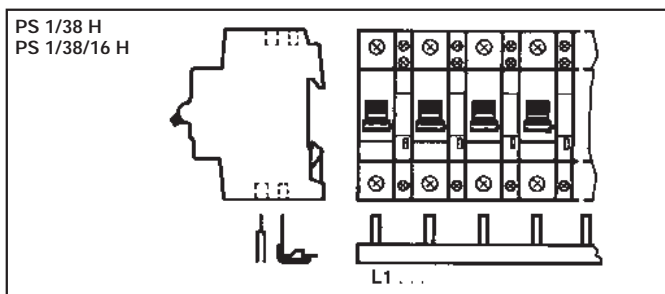
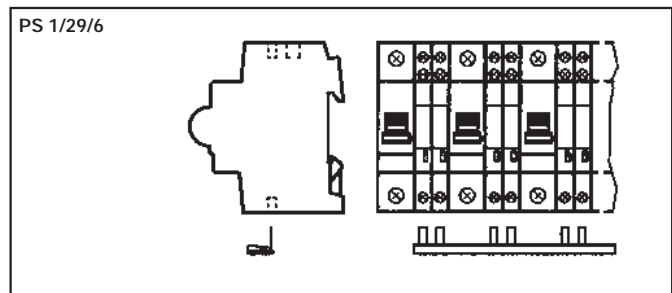
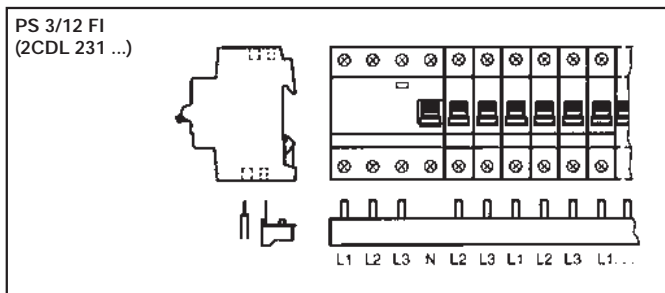
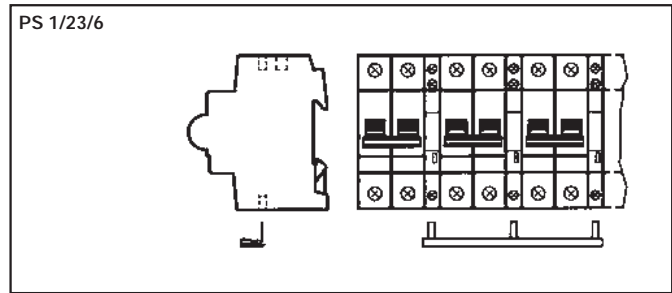
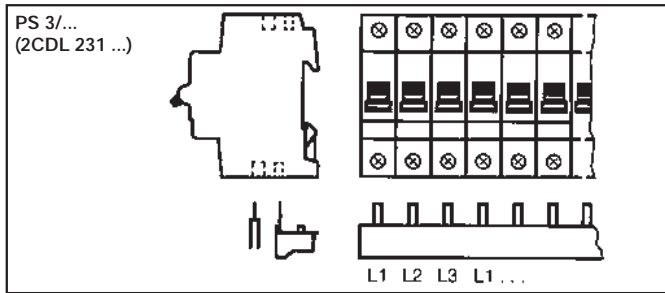
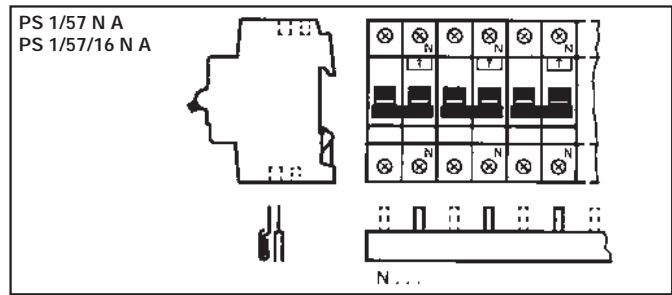
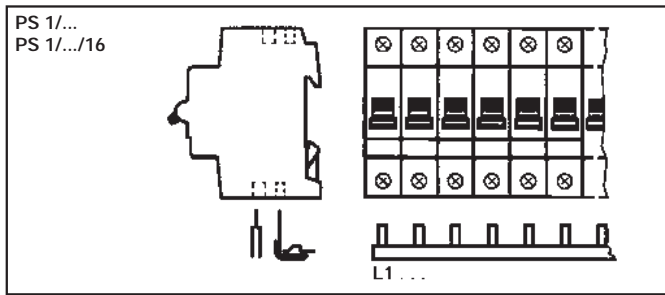

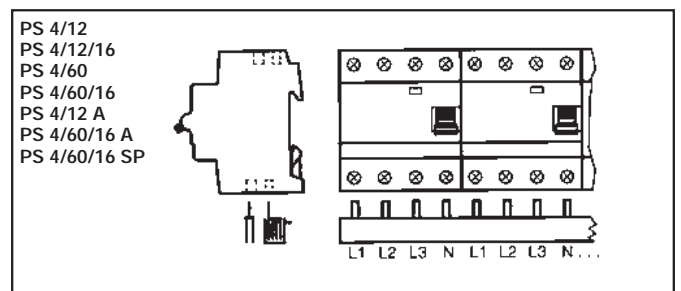
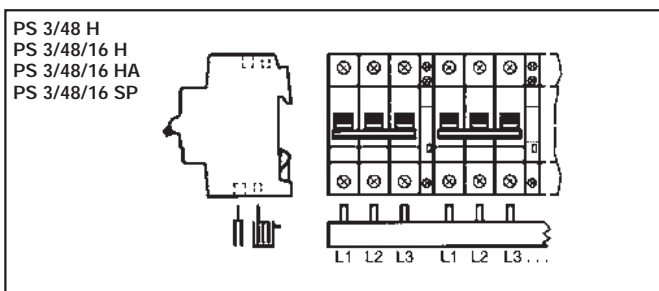
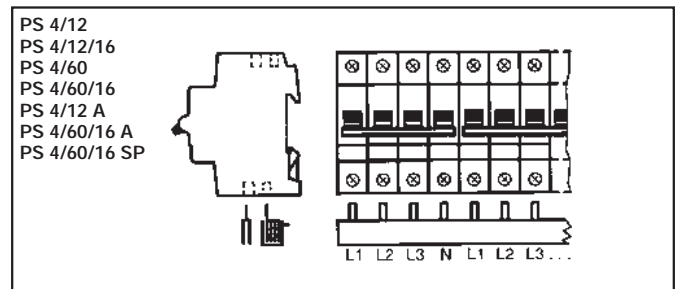
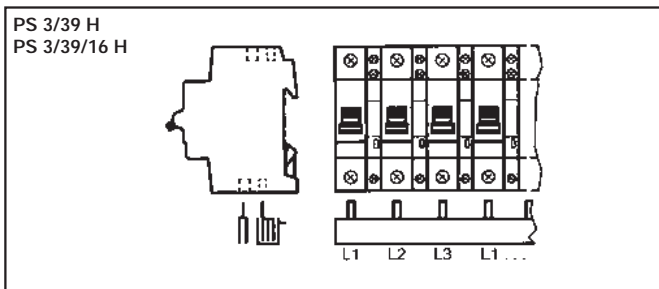
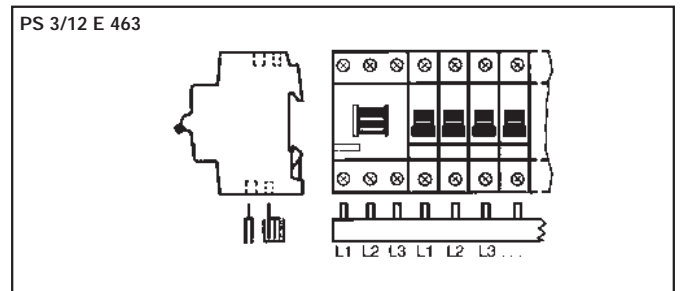
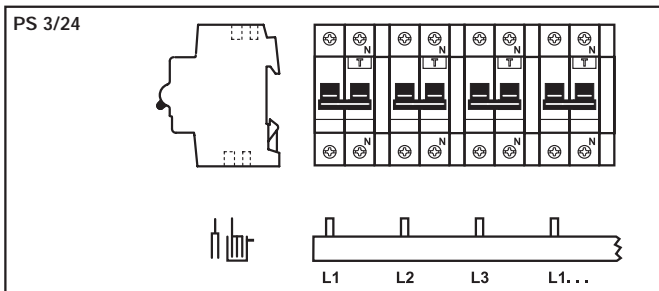
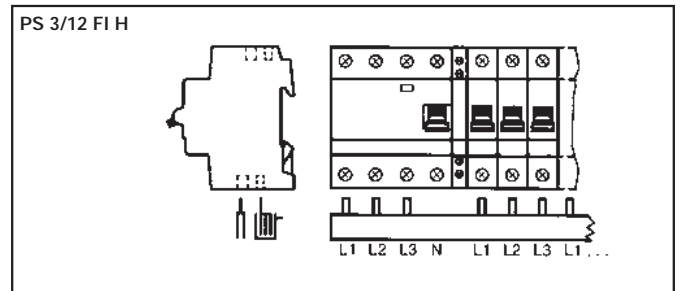
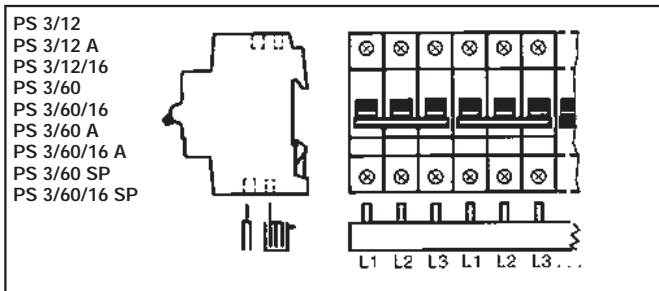
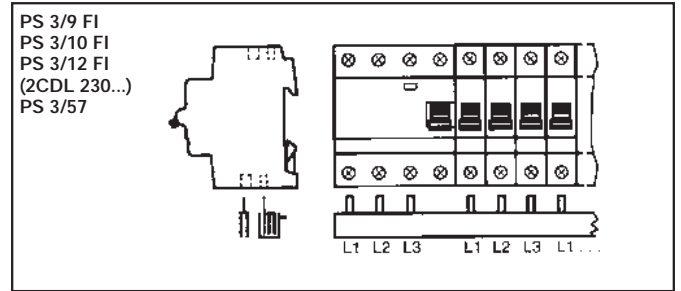
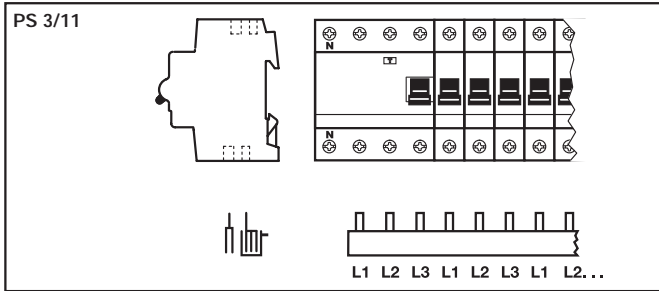
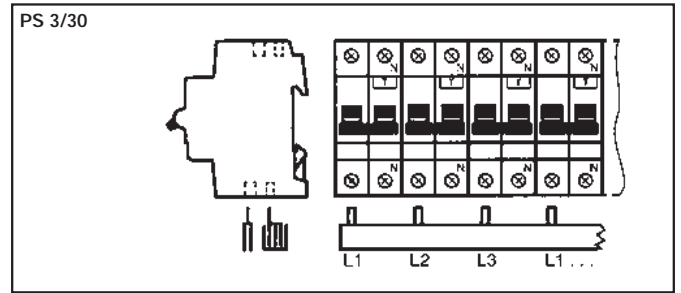
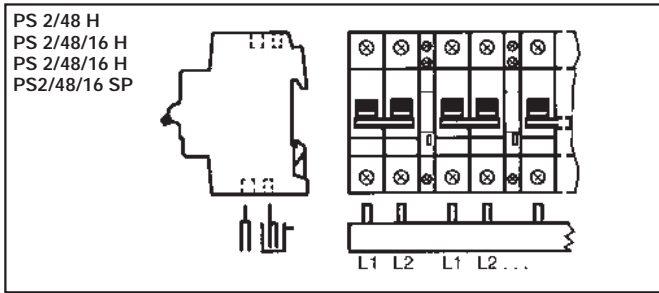

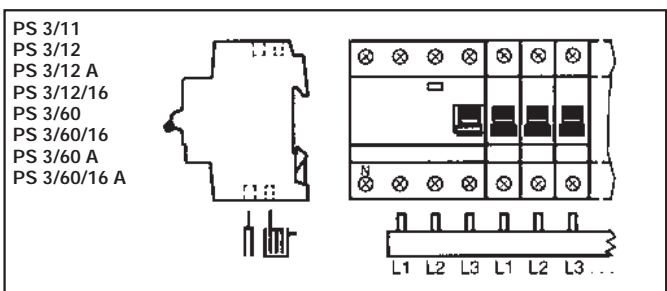
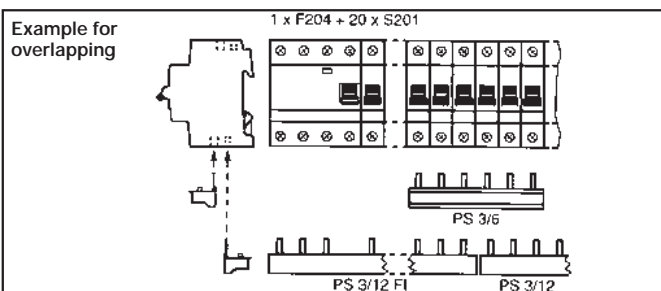
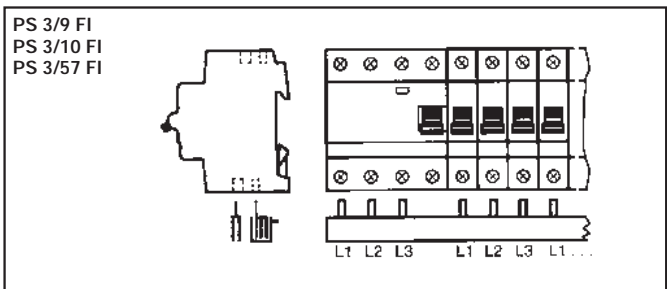
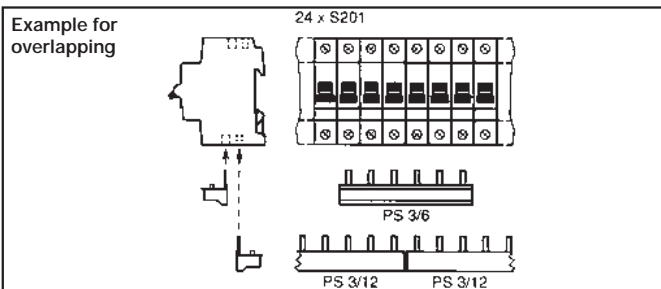
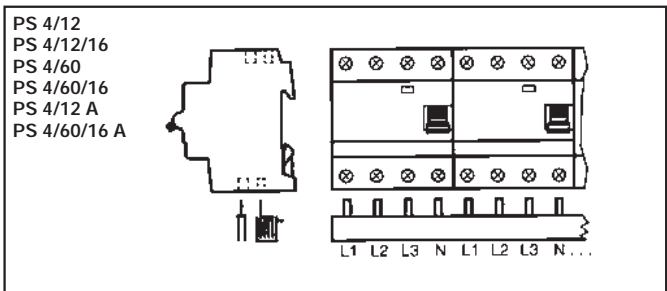
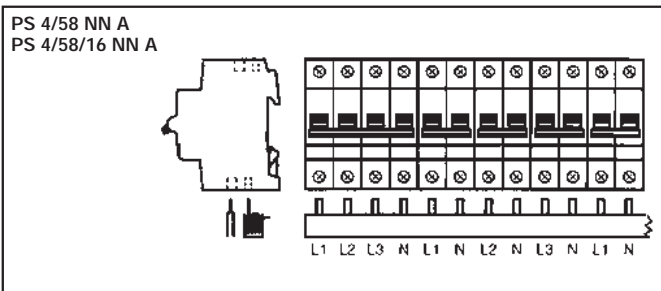
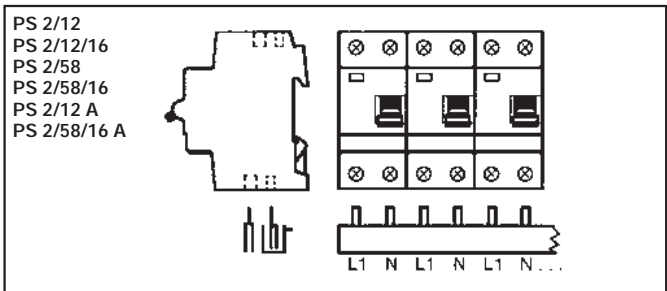
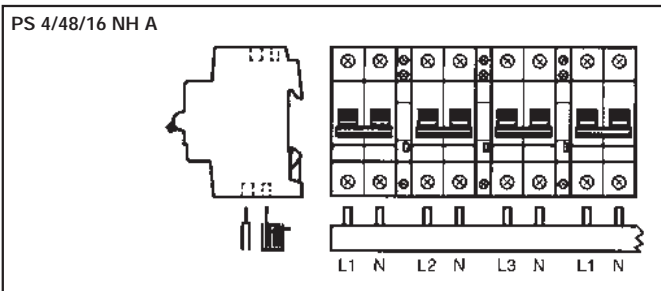
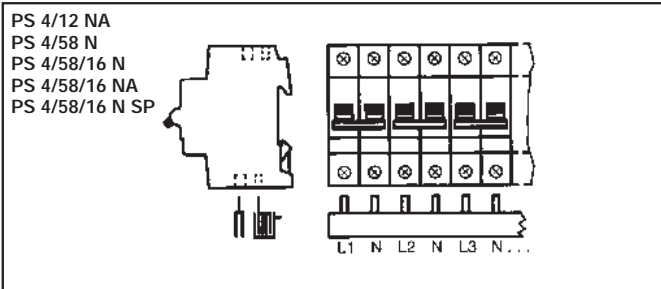
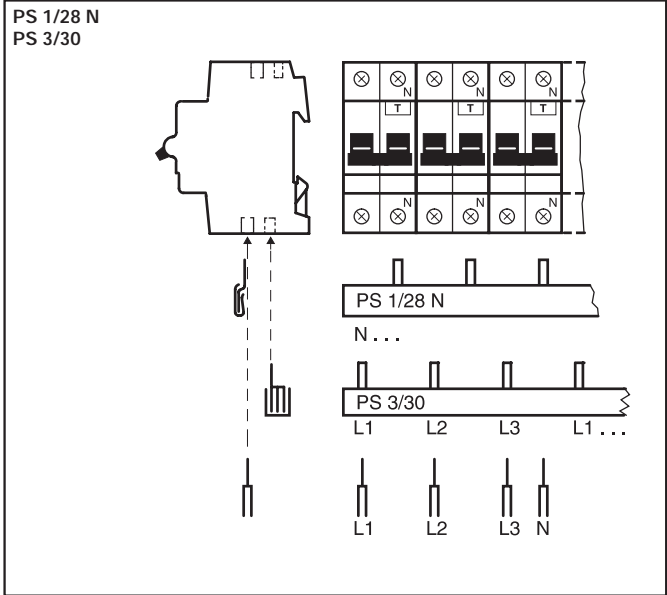
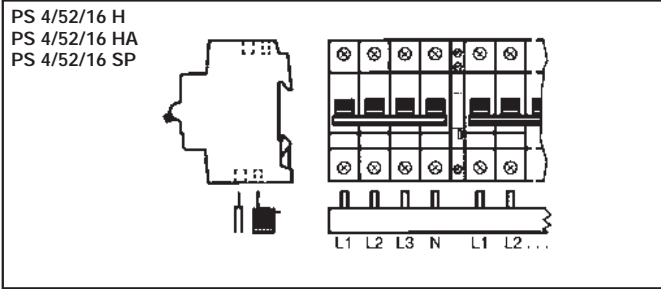



Rail connectors

For wiring of component rails in the consumer unit, rail-to-rail clearance 125 mm. In the case of the 4-pole connector, the color of the N conductor is blue.

10	3-pole	RV 3	GH V036 0504 R0023	51238 1	0.080	25
10	4-pole	RV 4	GH V036 0504 R0024	51224 4	0.114	25

Auxiliary contact bridge

Wire jumper for integrated auxiliary contact S 200 H for series connections.

1/2 mod.	HKB	GH V036 0504 R0100	52313 4	0.001	1000
----------	------------	--------------------	----------------	-------	------

Shock-protection caps for PS...

5 parts	SZ-BSK	2CDL 200 001 R0011	42000 6	0.003	10
5 parts	BSK*	2CDL 200 001 R0012	649834	0.003	10

* closed version

Labelling system

Package comes with 40 labels, marked or blank. Blank labels can be labeled by hand with an indelible, waterproof pen or with computerised labelling systems (plotter).

identification labels blank	BS	GH S200 1946 R0001	47810 6	0.004	30
identification labels with pictograms	BS Pikto	GH S200 1946 R0002	47820 5	0.004	30
identification labels marked 4 x 1 – 10	BS 1/10	GH S200 1946 R0003	47830 4	0.004	30
identification labels marked 2 x 1 – 20	BS 1/20	GH S200 1946 R0004	47840 3	0.004	30
identification labels marked 1 – 40	BS 1/40	GH S200 1946 R0005	47850 2	0.004	30
identification labels marked 41 – 80	BS 41 – 80	GH S200 1946 R0006	58591 0	0.004	30
identification labels marked 81 – 120	BS 81 – 120	GH S200 1946 R0007	58592 7	0.004	30
identification labels marked 121 – 160	BS 121/160	GH S200 1946 R0008	58593 4	0.004	30

Identification system ILS

The ILS individual identification system for labels is a DIN A5 polyester film for ink jet and laser printers with high temperature resistance. (If laser printers are used, please check whether self-adhesive film with thickness of 250 µm can be fed.) Adhesive coating 3MTM9471 LE has obtained UL approval (file No. MH 11410). Two types of sheets exist: uncut for making individual labels or precut with 23 stripes (6x191 mm each) for labelling 11 devices (1-module width) per stripe. Word template can be downloaded from www.abb.de/stotz-kontakt. Can also be used as write-on labels (ink, ballpoint pen, pencil, marker).

1 sheet DIN A5 uncut for laser printer	ILS-L	2CDL 200 002 R0003	66307 6	0.011	1
1 sheet DIN A5 precut in 23 stripes (6 X 191 mm) for laser printer	ILS-LS	2CDL 200 002 R0004	66308 3	0.011	1
1 sheet DIN A5 uncut for inkjet printer	ILS-I	2CDL 200 002 R0005	66309 0	0.011	1
1 sheet DIN A5 precut in 23 stripes (6 X 191 mm) for inkjet printer	IILS-IS	2CDL 200 002 R0006	66310 6	0.011	1

4

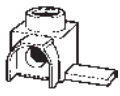

Ast 25/15 QS
Ast 25/15 Q
Ast 25/30 QS
Ast 25/30 Q
Ast 50/15 QS
Ast 50/15 Q
Ast 50/18 QU
Ast 50/32 Q

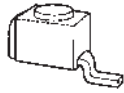

SZ-Ast 95 gk

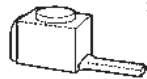

SZ-Ast 95

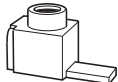

Ast 25/15 S
Ast 50/15 S
Ast 50/15
Ast 50/18 U

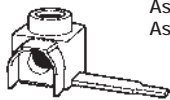

Ast 50/32 Q



SZ-ESK 2

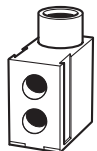

SZ-ESK 3

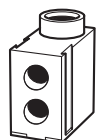

SZ-ESK 3 S



SZ-DB 121



SZ-DB 232 N



SZ-DB 125 N

2CSC400038F0201

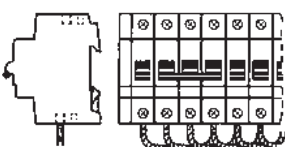

example 1
wiring of devices consisting of
modules with different lengths with
SZ-DB 125 N or 312

Conn. capacity	Terminal lug	Type of connection	Order details	Bbn	Cu No.	Price	Price group	Weight	Pack unit
mm ²	LxW mm		Type code	Order code	4016779	1 piece		1 piece	pc.
					EAN			kg	

Terminals, insulated with pin contact

6-25	15/4	90°	Ast 25/15 QS	2CDL200010R2515	656535	0.012		50
6-25	15/4	straight	Ast 25/15 S	2CDL200011R2515	656542	0.012		50
6-25	15/6	90°	Ast 25/15 Q	2CDL200000R2515	656474	0.012		50
6-25	30/4	90°	Ast 25/30 QS	2CDL200010R2530	656481	0.012		50
6-25	30/6	90°	Ast 25/30 Q	2CDL200000R2530	656498	0.014		50
6-50	15/4	90°	Ast 50/15 QS	2CDL200000R5015	656504	0.014		50
6-50	15/4	straight	Ast 50/15 S	2CDL200011R5015	656566	0.014		50
6-50	15/7	90°	Ast 50/15 Q	2CDL200010R5015	656559	0.014		50
6-50	15/7	straight	Ast 50/15	2CDL200001R5015	656511	0.014		50
5-50	17.5/7	90°	Ast 50/18 QU	2CDL200100R5018	656580	0.019		50
6-50	17.5/7	straight	Ast 50/18 U	2CDL200101R5018	656573	0.019		50
6-50	32/6	90°	Ast 50/32 Q	2CDL200000R5032	656528	0.017		50
25-95	21/6.5	straight	SZ-Ast 95 gk*	2CDL360501R0012	622618	0.06		0.067 50
25-95	21/6.5	straight	SZ-Ast 95*	2CDL360501R0013	622625	0.06		0.067 50

Abbreviations: Q terminal 90°
S narrow connection pin
U special for circuit breakers range S 200 U and S 200 UP
* not for pro M compact

Technical features

Connection capacity	6-25 mm ²	6-50 mm ²	25-95 mm ²
Max. electrical load	63 A	100 A	225 A
Max. operating voltage	600 V AC	600 V AC	690 V AC
Max. tightening torque	2 Nm	3 Nm	19 Nm

Feeder terminals

Single-pole terminals can be mounted side by side to multipole terminals.

6-35	SZ-ESK 2	2CDL200001R3501	646765	0.024	10
6-50	SZ-ESK 3	2CDL200003R5001	652575	0.025	10
6-50	SZ-ESK 3 S	2CDL200003R5003	652889	0.024	10

Flexible connecting wires

with fork-type cable lug (black)

Conn. capacity	Length	Order details	Bbn	Cu No.	Price	Price group	Weight	Pack unit
mm ²		Type code	Order code	4012233	1 piece		1 piece	pc.
				EAN			kg	
6	125	SZ-DB 121	GH V036 1425 R0001	55650 2	0.006		0.025	1000/50
10	135	SZ-DB 122 N	GH V036 1425 R0031	55670 0	0.010		0.02	500/25
6	260	SZ-DB 231 N	GH V036 1425 R0032	55680 9	0.014		0.02	500/25
10		SZ-DB 232 N	GH V036 1425 R0033	55690 8	0.022		0.04	250/25
10	330	SZ-DB 311	GH V036 1425 R0034	55700 4	0.029		0.05	100/25

with fork-type cable lug and ultrasonic compacted cable ends (black)

6	125	SZ-DB 123	GH V036 1425 R0006	55660 1	0.007		0.01	1000/50
10	135	SZ-DB 124 N	GH V036 1425 R0035	55710 3	0.012		0.02	500/25
6	260	SZ-DB 235	GH V036 1425 R0036	55720 2	0.014		0.02	500/25
10		SZ-DB 236	GH V036 1425 R0037	55730 1	0.024		0.04	250/25

with ultrasonic compacted cable ends (black)

6	125	SZ-DB 125 N	GH V036 1425 R0038	55740 0	0.007	0.01	1000/50
6	260	SZ-DB 233 N	GH V036 1425 R0039	55750 9	0.015	0.02	500/25
10	135	SZ-DB 126 N	GH V036 1425 R0040	55760 8	0.013	0.02	500/25
10	260	SZ-DB 234 N	GH V036 1425 R0041	55770 7	0.025	0.04	250/25
10	330	SZ-DB 312	GH V036 1425 R0042	55780 6	0.032	0.05	100/25

Advantages:

- at the same cross-section smaller dimensions (more space in terminal)
- nearly no transition resistances
- more reliability; conductor sleeves could be loosen under specific conditions

Input	Output	Order details	Bbn	Price	Price group	Weight	Pack unit
mm ²	mm ²	Type code	Order code	4012233	1 piece	1 piece	pc.
				EAN		kg	

Neutral or protective-conductor terminals without insulation holder

1 x 16	6 x to 16	SZ-6/3	GH V036 0876 R0003	50592 5 ①		0.022	10
1 x 16	2 x to 16 6 x to 10	SZ-KLB 8	GJ I232 0131 R0001	59660 7		0.025	30
1 x 16	2 x to 16 10 x to 10	SZ-KLB 12	GJ I232 0071 R0013	59530 3		0.035	30
1 x 35	4 x to 16 12 x to 10	SZ-KLB 16	GJ I232 0072 R0017	59540 2		0.077	30
1 x 35	4 x to 16 20 x to 10	SZ-KLB 24	GJ I232 0073 R0016	59550 1		0.100	30

Holders for SZ-KLB terminals

Screw-fixing
SZ-KLB 8 and 12 each 1 piece required
SZ-KLB 16 and 24 each 2 pieces required

	SZ-Ktr	GJ I202 4027 R0001	59450 4		0.003	100
--	---------------	--------------------	----------------	--	-------	-----

Neutral and protective-conductor terminals with insulation holder for quick fastening onto DIN rails EN 50022

Neutral with insulation holder blue; type C finger safe, conductor opening closed on one side

1 x 16	6 x 16	SZ-N 6/3	GH V036 0876 R0001	55570 3		0.027	20
1 x 16	11 x 16	SZ-N 11/3	GH V036 0876 R0002	55580 2		0.043	20
1 x 16	6 x 16	SZ-N 6/3 C	GH V036 0876 R0011	57095 4 ①		0.028	20
1 x 16	6 x 16	SZ-N 11/3 C	GH V036 0876 R0012	57096 1 ①		0.046	20

Protective conductor with insulation holder green/yellow; type C finger safe, conductor opening closed on one side

1 x 16	6 x 16	SZ-PE 6/3	GH V036 0876 R0004	55600 7		0.027	20
1 x 16	11 x 16	SZ-PE 11/3	GH V036 0876 R0005	55610 6		0.043	20
1 x 16	6 x 16	SZ-PE 6/3 C	GH V036 0876 R0014	57097 8 ①		0.028	20
1 x 16	11 x 16	SZ-PE 11/3 C	GH V036 0876 R0015	57098 5 ①		0.046	20

① bbn-No. 40 16779

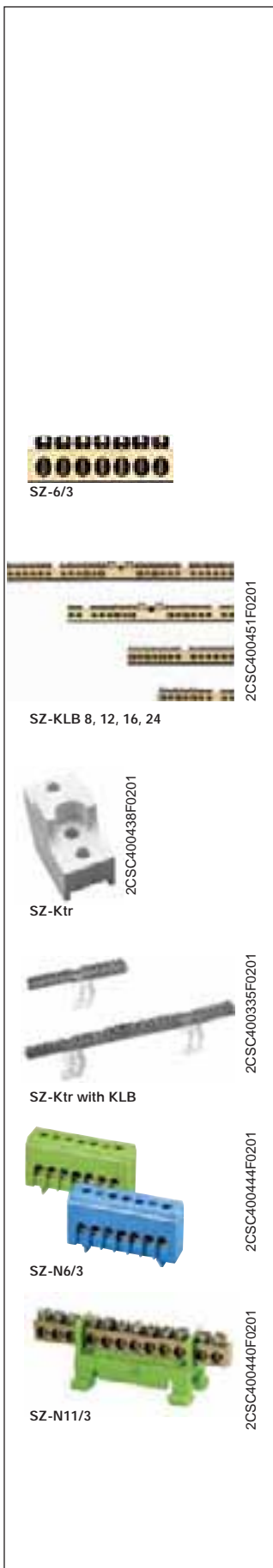

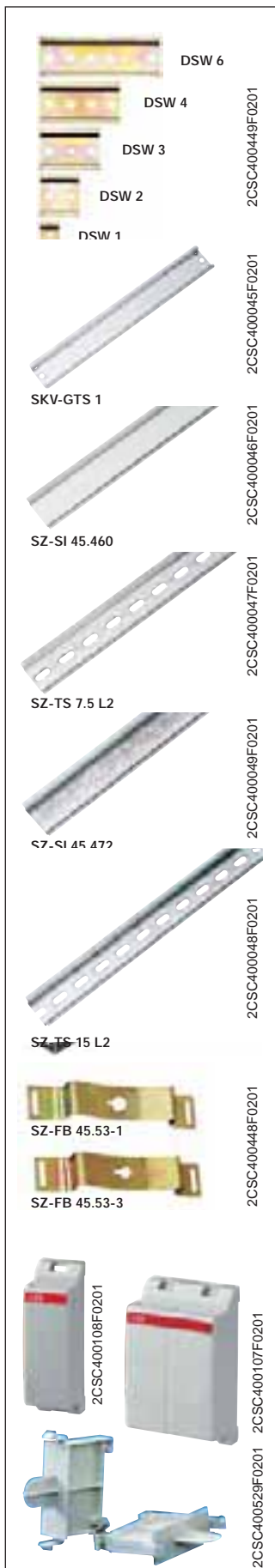

Length	Order details	Bbn	Price	Price group	Weight	Pack
mm	Type code	Order code	1 piece		1 piece	unit
		EAN			kg	pc.

DIN rails

DIN rails (DIN EN 60 715 – 35 x 7.5) for individual installation with 2 screws on an even surface (1 module = 17.5 mm)

	Order details	Bbn	Price	Weight	Pack
	Type code	Order code	1 piece	1 piece	unit
		EAN		kg	pc.
for 1 module	DSW 1	GH S210 1926 R0001	13580 6	0.060	10
for 2 modules	DSW 2	GH S210 1926 R0002	13590 5	0.012	10
for 3 modules	DSW 3	GH S210 1926 R0003	13600 1	0.018	10
for 4 modules	DSW 4	GH S210 1926 R0004	13610 0	0.024	10
for 6 modules	DSW 6	GH S210 1926 R0006	13620 9	0.036	10

DIN rail DIN EN 60 715, 35 x 7.5, material thickness 1 mm, surface protected, galvanised.

Length	Order details	Bbn	Price	Weight	Pack
mm	Type code	Order code	1 piece	1 piece	unit
		EAN		kg	pc.
241	SKV-GTS 1	GJ L110 1915 R0001	04090 2	0.09	40

DIN rails DIN EN 60 715, 35 x 7.5, material thickness 1 mm, surface galvanised.

Length	Order details	Bbn	Price	Weight	Pack
mm	Type code	Order code	1 piece	1 piece	unit
		EAN		kg	pc.
1000	SZ-SI 45.460	GJ I232 2218 R0001	59730 7	0.35	10
2000	SZ-TS 7.5 L2	GJ I232 2218 R0007	59760 4	0.70	20

DIN rails DIN EN 60 715, 35 x 15, material thickness 1.5 mm, surface galvanised

Length	Order details	Bbn	Price	Weight	Pack
mm	Type code	Order code	1 piece	1 piece	unit
		EAN		kg	pc.
2000	SZ-SI 45.472	GJ I232 2218 R0010	59780 2	1.30	10
2000	SZ-TS 15 L2	GJ I232 2218 R0009	59770 3	0.78	10

Catch spring for mounting devices onto DIN rails (DIN EN 60 715, 35 x 7.5)

	Order details	Bbn	Price	Weight	Pack
	Type code	Order code	1 piece	1 piece	unit
		EAN		kg	pc.
for screw type M4	SZ-FB 45.53-3	GJ I184 2013 P0003	64560 2	0.03	50
for screw type M5	SZ-FB 45.53-1	GJ I184 2013 P0004	64580 0	0.03	50

False poles

Description	Order details	Bbn	Price	Price group	Weight	Pack
	Type code	Order code	1 piece		1 piece	unit
		EAN			kg	pc.
False pole - 1 module	FP1	16021765	061304		0.01	100
False pole - 2 modules	FP2	16021773	061403		0.014	50
False pole - 4 modules	FP4	16021781	061502		0.022	30
False pole - 6 modules	FP6	16021799	061601		0.031	20
Support for false pole	SFP	16021831	061700		0.012	100



Height of cutout/color	Width	Order details	Bbn	Price	Price	Weight	Pack
mm	mm	Type code	4012233	1 piece	group	1 piece	unit
			EAN			kg	pc.

Blanking plates

For device covers with materials of a thickness of 1 to 3 mm, width: 1 module = 17.5 mm; color: grey RAL 7035, white RAL 9001

46/grey	213	SZ-BP 1	GH L530 1904 R0001	06050 4		0.028	100
46/white	17.5	SZ-BP	GH S270 1913 R0001	12857 4 ①		0.005	
46/grey	17.5	SZ-BP 2	GH S270 1913 R0002	12861 1 ①		0.005	
46/grey	220	SZ-BP 12 G	2CDL 000 001 R1220	65227 8 ①		0.022	50

Description	Order details	Bbn	Price	Price	Weight	Pack
	Type code	4012233	1 piece	group	1 piece	unit
		EAN			kg	pc.

Locking devices for SZ-BP 12 G	SZ-BP R	2CDL 000 001 R1001	652285 ①		0.001	30
--------------------------------	----------------	--------------------	-----------------	--	-------	----

① bbn-Nr. 80 00126

Sealing plate

Seal-proof locking of stamped-out device covers.
Detachable only from the inside of the device cover.
Can be used for device covers with 1.5 to 3 mm material thickness.

Height of cutout/color	Width	Order details	Bbn	Price	Price	Weight	Pack
mm	mm	Type code	4012233	1 piece	group	1 piece	unit
			EAN			kg	pc.

46/grey	1500	SZ-VP 1500	GJ I995 9038 R0001	60290 2		0.366	10
---------	------	-------------------	--------------------	----------------	--	-------	----

Rotary operating mechanism

(for operation of MCBs in closet distribution boards)
Suitable for S 2 classic and S 200 compact series to be combined with selection types handles OH_2_ and consistent extended shafts OXS 5X_.

	S2C-DH	GH S200 1901 R0003	57960 5 ①		0.01	25
--	---------------	--------------------	------------------	--	------	----

① bbn-Nr. 4016779

End bracket

Prevents lateral shifting of built-in devices mounted on DIN rails according to DIN EN 60 715, 35 x 7.5 mm.

	END	GJ I100 1814 R0001	59090 2		0.02	50
--	------------	--------------------	----------------	--	------	----

Filling piece

For e.g. heat dissipation of closely mounted devices that generate much heat.
Width 8.75 mm, as spacer, two different heights, breakable, for DIN rails according to DIN EN 60 715, 35 x 7.5 mm.

8.75	SZ-FST 2	GH L530 1908 R0002	06070 2		0.01	25
------	-----------------	--------------------	----------------	--	------	----

Spring piece

Holder for device covers, various heights available (in connection with filling piece FST 2)

	SZ-FDT 2	GH L530 1908 R0005	06080 1		0.002	25
--	-----------------	--------------------	----------------	--	-------	----

Filling piece

Two different heights, breakable, for DIN rails according to DIN EN 60 715, 35 x 7.5 mm for MCBs S 220 (3 different heights)

8.75	SZ-FST	GH I148 0003 R0001	59410 8		0.01	25
------	---------------	--------------------	----------------	--	------	----



SZ-ES 68/83

2CSC400447F0201



SA 1

2CSC400453F0201



SA 2

2CSC400454F0201

2CSC40053F0201

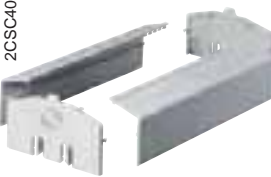

KA 27 H + KA 27 S



PCD 2 N



PCD 4 N

2CSC400435F0201



PCD 8 N

2CSC400437F0201

Description	Order details		Bbn 4012233	Price 1 piece	Price group	Weight 1 piece	Pack unit
	Type code	Order code					

Elevation piece

Compensates for different size of built-in devices with a mounting height of 68 mm and power MCBs of series S 500 (83 mm)

Description	Type code	Order code	Bbn	Price	Price group	Weight	Pack unit
SZ-ES 68/83		GH V021 1425 R0001	53390 9			0.003	100

Locking device for MCBs and switches

Prevents unauthorised or dangerous operation of the operating lever. An adaptor makes it possible to block the operating lever whether switched ON or OFF. The lever is blocked with a padlock having a cross bar section of 3 or, as the case may be, 6 mm max. For multipole devices, one lock may be fitted per pole.

The lock adaptor can be used for all MCBs of the S 220, S 280 series as well as for switches E 220 and 270.

Description	Type code	Order code	Bbn	Price	Price group	Weight	Pack unit
locking devices for padlock bar 3 mm	SA 1	GJ F110 1903 R0001	58760 5			0.004	10
locking devices for padlock bar 6 mm	SA 1E	GJ F110 1903 R0004	58790 2			0.004	10
padlock with 2 keys	SA 2	GJ F110 1903 R0002	58770 4			0.02	10
padlock, identical locking with 2 keys	SA 2 i	GJ F110 9999 R0001	96940 1			0.02	10
lock adaptor incl. padlock with 3 keys in transparent box	SA 3	GJ F110 1903 R0003	58780 3			0.05	10

Terminal cover KA 27

Provides overall touch protection of live parts. Suitable for installations acc. to DIN EN 50274 (DIN VDE 0660 Part 514) and BGV A2.

End parts can be snapped onto mounting rails EN 60 715, 35 mm. Covers are 486 mm = 27 modules (18 mm each) long. Knockouts for each half module for individualised use.

Description	Type code	Order code	Bbn	Price	Price group	Weight	Pack unit
cover, 1 piece	KA 27 H	GH S210 1933 R0001	13630 8			0.104	10
end part, 1 piece	KA 27 S	GH S210 1934 R0001	13640 7			0.027	10

Terminal covers with base plate, protection IP 40

Material: high-impact and flame-retardant (UL 94 V-0), color: white (RAL 9001), glow-wire test 960 °C according to IEC 695-2-1

The base plate has an integrated top-hat rail for snap-on fixing of MCBs, RCDs, modular built-in devices, etc.

Description	Type code	Order code	Bbn	Price	Price group	Weight	Pack unit
for 2 modules	PCD 2 N	GH S270 1921 R0002	12402 6①			0.09	1
for 4 modules	PCD 4 N	GH S270 1921 R0004	12404 0①			0.15	1
for 6 modules	PCD 6 N	GH S270 1921 R0006	12406 4①			0.2	1
for 8 modules	PCD 8 N	GH S270 1921 R0008	12408 8①			0.7	1

Common terminals for terminal covers PCD

Description	Type code	Order code	Bbn	Price	Price group	Weight	Pack unit
for PCD 4 N and 6 N	KL-PCD 4/6	GH S270 1912 R0004	12502 3①			0.017	
for PCD 8 N	KL-PCD 8	GH S270 1912 R0008	12592 7①			0.079	

① bbn-No. 80 00126



2CSC400410F0201

QES 4/3 N

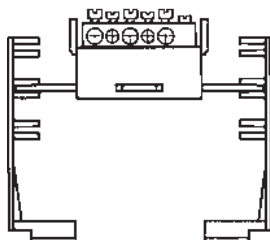

SMO...



2CSC400533F0201

Insulated housings IP 55

come with DIN rail according to DIN EN 60 715 and cable entry grommet without N + PE common terminals (see SMO)

Material: high-impact and flame-retardant (UL 94 V-0), color grey (RAL 7035), glow-wire test 960 °C according to IEC 695-2-1

Type with knock-outs ø in mm	Enclosed cable grommets	Order details Type code	Order code	Bbn 8000126 EAN	Price 1 piece	Price group	Weight 1 piece kg	Pack unit pc.
---------------------------------	-------------------------	----------------------------	------------	-----------------------	------------------	-------------	-------------------------	------------------

housings for 4 modules

2 x Ø 27	2	QES 4/3 N	GH L111 2304 R0013	12644 0			0.370	18
----------	---	-----------	--------------------	---------	--	--	-------	----

housings for 6 modules

2 x Ø 27	2	QES 6/3 N	GH L111 2306 R0013	12646 4			0.440	12
----------	---	-----------	--------------------	---------	--	--	-------	----

housings for 10 modules

6 x Ø 32	3	QES 10/3 N	GH L111 2310 R0013	12650 1			0.690	10
----------	---	------------	--------------------	---------	--	--	-------	----

N + PE common terminals for QES (IP 55)

Neutral and protective-conductor terminals with insulation holder for screw-fixing

Description	Order details Type code	Order code	Bbn 4012233 EAN	Price 1 piece	Price group	Weight 1 piece kg	Pack unit pc.
for QES 4/3 N	SMO 4	GH L430 1910 R0004	12880 2			0.093	10
for QES 6/3 N	SMO 6	GH L430 1910 R0006	12882 6			0.125	10
for QES 10/3 N	SMO 10	GH L430 1910 R0010	12884 0			0.105	10

Flanges

Description	Order details Type code	Order code	Bbn 8000126 EAN	Price 1 piece	Price group	Weight 1 piece kg	Pack unit pc.
Flange for rear board fixing 1 module - IP40	ME 1	16219300	304401			0.040	1
Flange for rear board fixing 2 modules - IP40	ME 2	16219318	304500			0.045	1
Flange for rear board fixing 3 modules - IP40	ME 3	16219326	304609			0.055	1
Flange for rear board fixing 4 modules - IP40	ME 4	16219334	304708			0.060	1
Flange for rear board fixing 6 modules - IP40	ME 6	16219342	304807			0.070	1
Flange for rear board fixing 8 modules - IP40	ME 8	16219359	304906			0.080	1

For the MCBs S 9.. and the RCBOs DS 9.. series, shunt trips, undervoltage releases and contacts (auxiliary and signal) are available.

These elements provide additional functions and they are all coupled directly to the circuit-breaker without the use of other components such as pins or clips.

The auxiliary contact is equipped with a green indicator which shows the position of the circuit-breaker (when the circuit-breaker is in the "open" position the indicator protrudes). The same indicator also enables a test of the auxiliary circuit.

The signal contact is equipped with a yellow indicator which protrudes out when the circuit-breaker trips. This indicator also resets manually the signal circuit (RESET).

The signal contact is also equipped with a test button (TEST) which tests the signal contact irrespective of the state of the MCB.

On each circuit-breaker in the S 9.. range, up to a maximum of 3 contacts can be used (the signal contact, if necessary, should be installed directly on the circuit-breaker and only one can be used).

Shunt trips and undervoltage releases are equipped with a protruding red indicator which shows opening of the circuit-breaker (if caused by the release).

There are also two versions of the undervoltage releases equipped with a tripping delay of 100 ms (S 9-V24CA and S 9-V24CC types), which prevents unwanted tripping caused by microinterruption or drop in the network voltage which lasts less than 100 ms.



ABB Auxiliary elements and accessories for S 9.. and DS 9.. series



Index

Schemes for combination of auxiliary elements and S 9.. and DS 9.. series	4/30
Technical features of auxiliary elements for S 9.. and DS 9.. series	4/31
Selection tables of auxiliary elements and accessories for S 9.. and DS 9.. series	
Shunt trips	4/32
Signal/auxiliary contact.....	4/32
Undervoltage releases.....	4/32
Busbars	4/33

Combination between auxiliary elements and S 9/DS 9

4

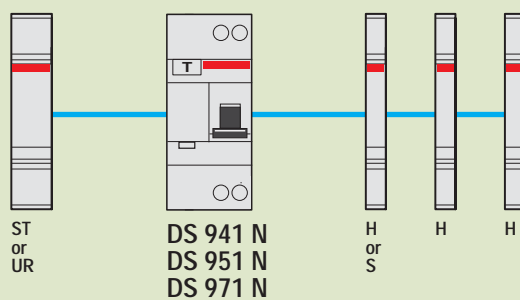
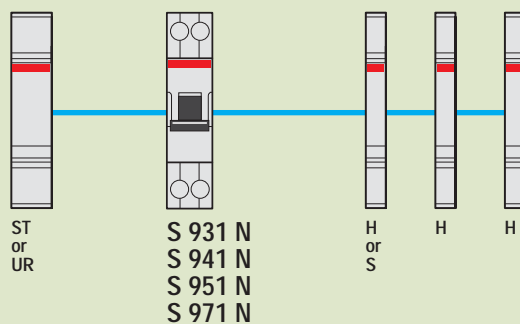

H	Auxiliary contact
S	Signal contact
ST	Shunt trip
UR	Undervoltage release

Technical characteristics of shunt trips

Type		S9-T24	S9-T130	S9-T415
Voltage	[V] a.c.	12...24	48...130	220...415
	[V] d.c.	12...24	48...60	110...250
Frequency	[V]		50...60	
Consumption on release	[VA]	20 VA (12 V a.c.)	22 VA (48 V a.c.)	40 VA (220 V a.c.)
		90 VA (24 V a.c.)	200 VA (130 V a.c.)	130 VA (415 V a.c.)
		20 VA (12 V d.c.)	22 VA (48 V d.c.)	10 VA (110 V d.c.)
		90 VA (24 V d.c.)		20 VA (250 V d.c.)
Terminals	[mm ²]		2x1.5	

Technical characteristics of undervoltage releases

Type		S9-V24CA	S9-V24CC	S9-V48CA	S9-V48CC	S9-V230CA
Voltage	[V] a.c.	24	-	48	-	230
	[V] d.c.	-	24	-	48	-
Frequency	[Hz]			50...60		
Consumption on release	[VA]	6	2	4.3	2	4.3
Terminals	[mm ²]			2x1.5		

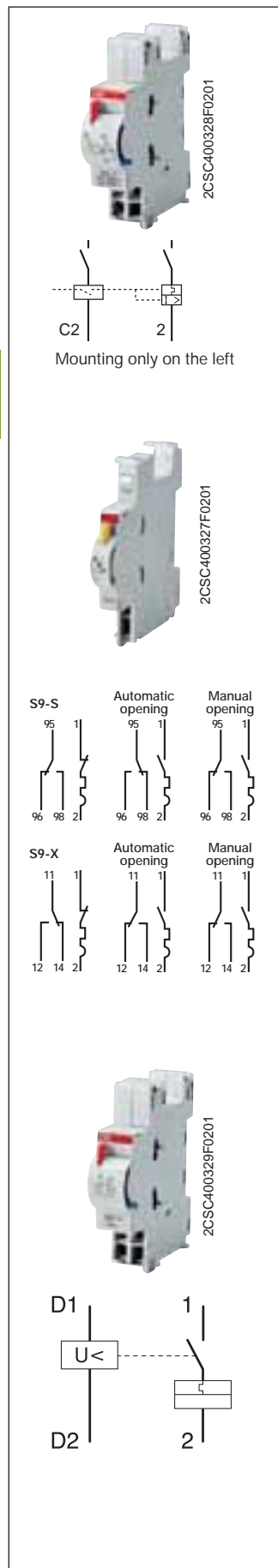

Shunt trips

Function: remote opening of the device when a voltage is applied.
With transformer TM 30, 10 undervoltage releases S9-T24 at 12 V AC (TM 30/12) and 9 undervoltage releases S9-T24 at 24 V AC (TM 30/24) can be fed.
With transformer TM 40, 9 undervoltage releases S9-T24 at 12 V AC (TM 30/12) and 9 undervoltage releases S9-T24 at 24 V AC (TM 30/24) can be fed.
Suitable for MCBs S 931, S 941, S 951 and S 971 series, RCBOs DS 941, DS 951 and DS 971 series.

Description	Order details		Bbn 8012542 EAN	Price 1 piece	Price group	Weight 1 piece kg	Pack unit pc.
	Type code	Order code					
12-24 V a.c./d.c.	S9-T24	16056191	402701			0.100	1
48-130 V a.c./48-60 d.c.	S9-T130	16056209	402800			0.100	1
220-415 V a.c./ 110-250 V d.c.	S9-T415	16056217	402909			0.100	1

Auxiliary contact

Function: indication of the position of the device's contacts.
Suitable for MCBs S931, S941, S951 and S971 series, RCBOs DS941, DS951 and DS971 series.

Signal contact

Function: indication of the position of the device's contacts only after the automatic release of the MCBs and RCBOs due to an overload or a short-circuit.
Suitable for MCBs S 931, S 941, S 951 and S 971 series, RCBOs DS 941, DS 951 and DS 971 series.

Description	Order details		Bbn 8012542 EAN	Price 1 piece	Price group	Weight 1 piece kg	Pack unit pc.
	Type code	Order code					
aux. contact 1 NO + 1 NC	S9-X	16056100	372202			0.040	1
signal contact 1 NO + 1 NC	S9-S	16056118	372301			0.040	1

Undervoltage releases

Function: protection of the load in the event of a voltage drop (between 70% and 35% of its rated value); positive safety (device's tripping when the voltage is disconnected) emergency stop by means of a button.
Suitable for MCBs S 931, S 941, S 951 and S 971 series, RCBOs DS 941, DS 951 and DS 971 series.

Description	Order details		Bbn 8012542 EAN	Price 1 piece	Price group	Weight 1 piece kg	Pack unit pc.
	Type code	Order code					
24 V a.c. with delay	S9-V24CA	16056126	372400			0.100	1
24 V d.c. with delay	S9-V24CC	16056134	372509			0.100	1
24 V a.c.	S9-V48CA	16056142	372608			0.100	1
24 V d.c.	S9-V48CC	16056159	372707			0.100	1
230 V a.c.	S9-V230CA	16056167	372806			0.100	1

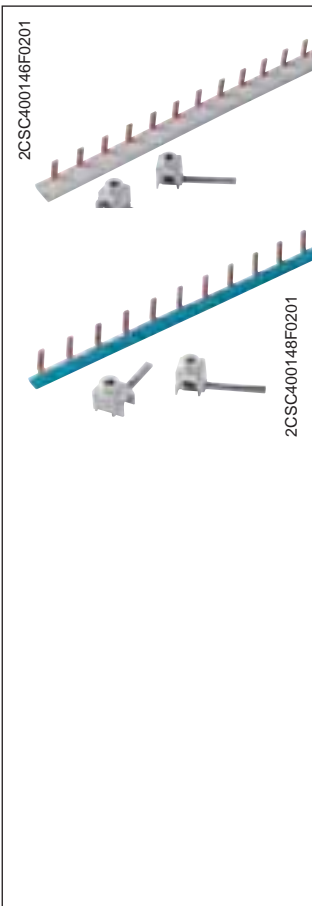

Busbars for S9 and DS9 ranges

No. pins	Phases	Cross section mm ²	Order details Type code	Order code	Bbn 8012542 EAN	Price 1 piece	Price group	Weight 1 piece kg	Pack unit pc.
12	1	10	BS9 1/12	2CSL910001R1012	047650			0.050	10
12	1	10	BS9 1/12 NA	2CSL910011R1012	047759			0.050	10
56	1	10	BS9 1/56	2CSL910001R1056	047353			0.140	10
56	1	10	BS9 1/56 NA	2CSL910011R1056	047452			0.140	10
12	3	10	BS9 3/12	2CSL930001R1012	047551			0.090	5
57	3	10	BS9 3/57	2CSL930001R1057	047858			0.470	5

Busbars for F200/S200 and S9/DS9 range

2 + 10 x 1+N	2	10	BF2-S9 UP 1N/12	2CSL920009R1012	046950			0,110	5
4 + 8 x 1+N	4	10	BF2-S9 UP 3N/12	2CSL940009R1012	047056			0,110	5
2 + 10 x 1+N	2	10	BF2-S9 DOWN 1N/12	2CSL920002R1012	047155			0,110	5
4 + 8 x 1+N	4	10	BF2-S9 DOWN 3N/12	2CSL940002R1012	047254			0,110	5

Terminals, insulated

Conn. capacity mm ²	Type of connect.	Terminal lug L mm	Order details Type code	Order code	Bbn 8012542 EAN	Price 1 piece	Price group	Weight 1 piece kg	Pack unit pc.
25	pin	15	FEED-IN 25/15 1P	2CSL980001R2515	047957			0.010	5
25	pin	30	FEED-IN 25/30 3P	2CSL980001R2530	048053			0.010	5

End caps

Order details Type code	Order code	Bbn 8012542 EAN	Price 1 piece	Price group	Weight 1 piece kg	Pack unit pc.
BS9-END 3P ①	2CSL980001R0001	064251			0.001	20

① In combination with BS9 3/57

Example of application with S 9.. breakers

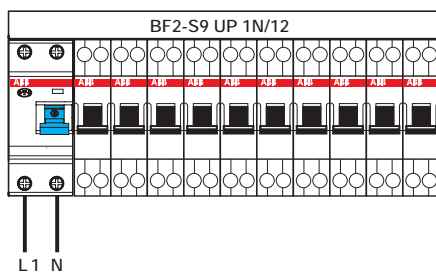
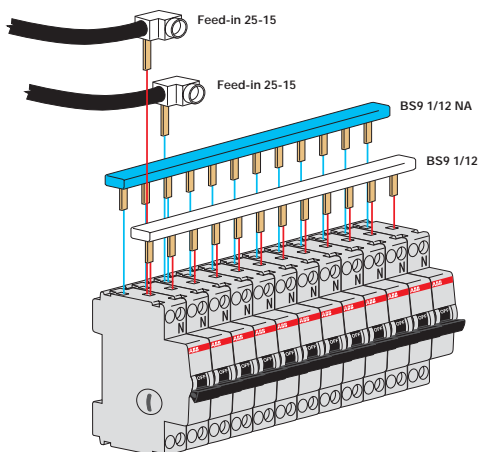

Example of application with DS 9.. breakers

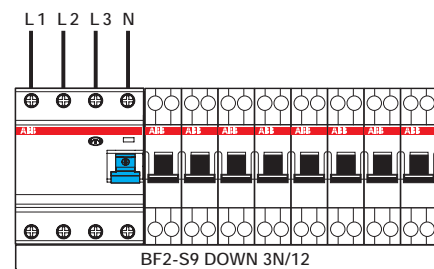
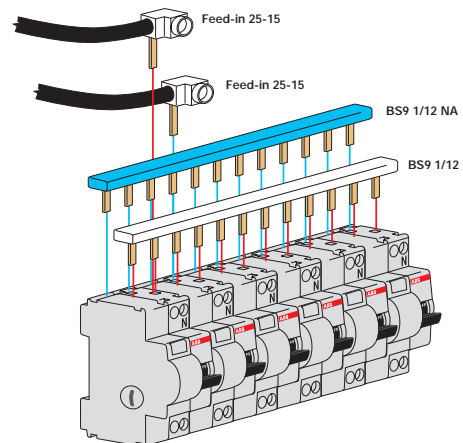

The S 280 and S 280 UC series of MCBs are supported by a whole group of auxiliary elements with many functions and configurations.

Undervoltage releases, shunt trips, auxiliary contacts, signal contacts, mechanical interlocks are available. A wide range of auxiliary elements considerably improves the performance of the MCBs and enables innovative and integrated solutions to be used in every installation.

The S 290 circuit-breakers are supplied with special shunt trips, undervoltage releases and contacts (auxiliary and signal). All the accessories are installed to the right of the circuit-breaker. The left part is used for installing RCD blocks.

Also S800 MCBs series is completed with a wide range of accessories which includes auxiliary and signal contacts, separating neutral, rotary handles and interchangeable adapter kits.

All the auxiliary elements are installed to the left side of the circuit breakers.

The right part is used for installing DDA 800 RCD blocks.



ABB Auxiliary elements and accessories for MCBs S 280, S 290 and S800 series and for RCD-blocks DDA 800



Index

Schemes for combination of auxiliary elements and MCBs S 280 series	4/36
Technical features of auxiliary elements for MCBs S 280 series	4/36
Selection tables of auxiliary elements for MCBs S 280 series	
Shunt trips	4/38
Signal/auxiliary contacts.....	4/38
Undervoltage releases.....	4/39
Schemes for combination of auxiliary elements and MCBs S 290 series	4/40
Technical features of auxiliary elements for MCBs S 290 series	4/41
Selection tables of auxiliary elements for MCBs S 290 series	
Shunt trips	4/42
Signal/auxiliary contact.....	4/42
Undervoltage releases.....	4/42
Schemes for combination of auxiliary elements and MCBs S800 series	4/43
Technical features of auxiliary elements for MCBs S800 series	4/44
Selection tables of auxiliary elements and accessories for MCBs S800 series	
Short-circuit current limiters with cage terminal.....	4/46
Short-circuit current limiters with ring terminal cable connection	4/46
Auxiliary contact	4/46
Signal/auxiliary contact.....	4/46
Separating neutral	4/46
Accessories	4/47

Combination between auxiliary elements and S 280

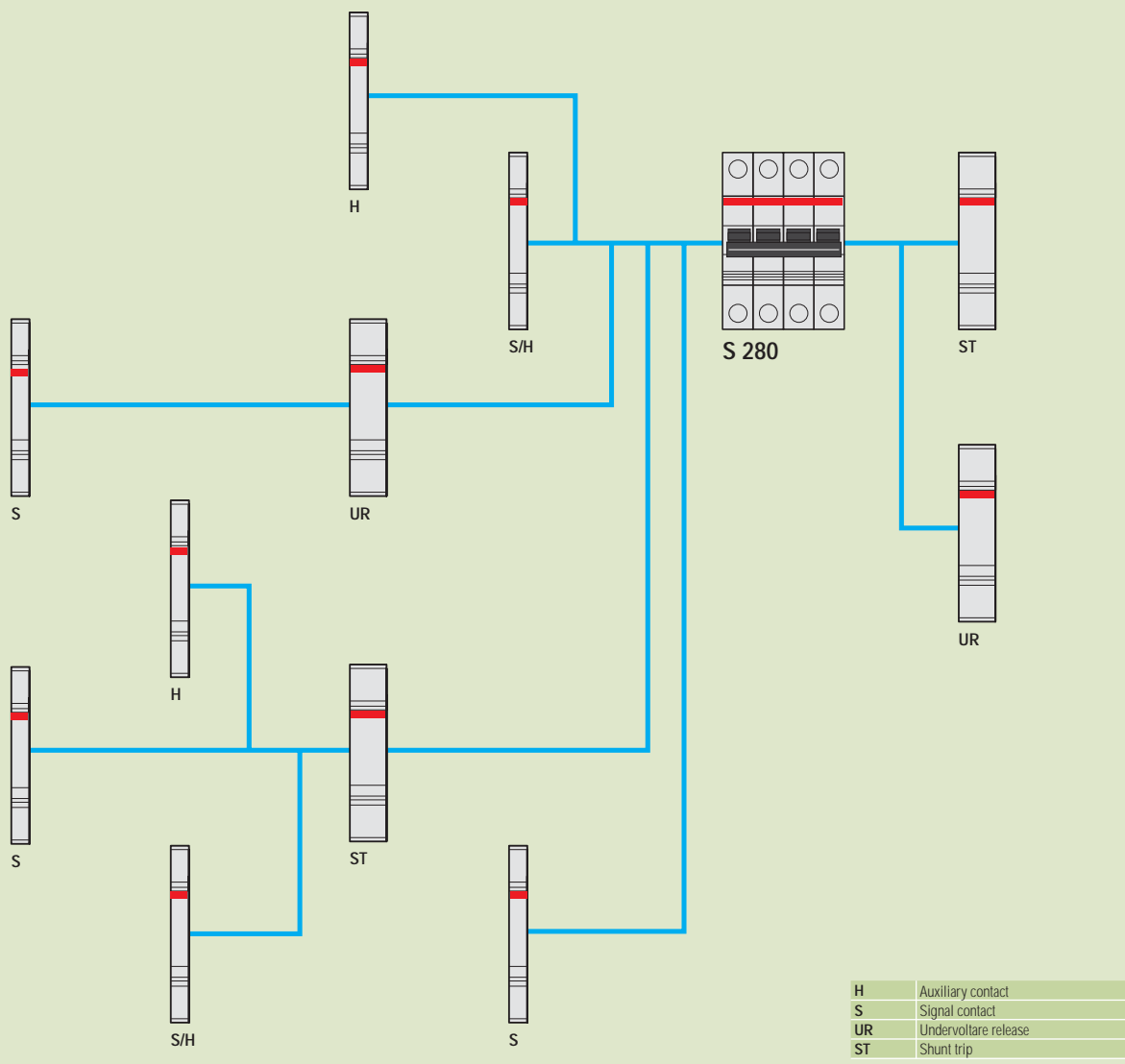

H	Auxiliary contact
S	Signal contact
UR	Undervoltage release
ST	Shunt trip

Technical characteristics of auxiliary and signal contacts

Type	S2-H11 I S2-H11 X	S2-H20 I S2-H20 X	S2-H02 I S2-H02 X	S2-H21	S2-H12	S2-H30	S2-H03
Description	1NO+1NC	2NO	2NC	2NO+1NC	1NO+2NC	3NO	3NC
Alternating current	Ue [V]			240 415			
	Ie [A]			6 2			
Direct current	Ue [V]		24	60 110 250			
	Ie [A]		4	2 1.5 1			
Min. operating voltage	[V]			12 a.c.-12 d.c.			
Min. operating current	[mA]			12			
Terminals	[mm ²]			up to 2x1.5			
Dielectric strength	[kV]			3			
Resistance to short-circuit at 240 V a.c.	[A]		1000 (protected with S 2 breaker characteristic K - 6 A)				
Impulse voltage withstand capacity	[kV]			4			
Tightening torque	[Nm]			0.7			
Dimensions (WxDxH)	[mm]			8.75x68x90			

NB: the auxiliary contacts S2-H11 X, S2-H20 X, S2-H02 X differ from the contacts S2-H11, S2-H20, S2-H02 in that they do not have a terminal to tighten the cable which is replaced by a bayonet for the Faston connection.

Technical characteristics of shunt trips

Type		S2-A1	S2-A2
Rated voltage	[V]		
	a.c.	12 - 60	110 - 415
	d.c.	12 - 60	110 - 250
Max. release duration	[ms]	<10	<10
Min. release voltage	[V]		
	a.c.	7	55
	d.c.	10	80
Consumption on release	[VA]		
	12 V a.c.	35	
	12 V d.c.	30	
	24 V a.c.	140	
	24 V d.c.	100	
	48 V a.c.	600	
	48 V d.c.	330	
	110 V a.c.		40
	110 V d.c.		40
220 V a.c.		180	
220 V d.c.		170	
Coil resistance	[Ω]	3.7	225
Terminals	[mm ²]	25	25
Tightening torque	[Nm]	2	2
Dimens. (WxDxH)	[mm]	17.5x68x90	17.5x68x90

Technical characteristics of undervoltage releases

Type		S2-BM1	S2-BM2	S2-BM3	S2-BM4	S2-BM5	S2-BM6
Standards		VDE0660 part I - IEC EN 60947.1					
Rated voltage	[V] a.c.	-	24	48	110	220-240	380
	[V] d.c.	12	24	48	110	220	-
Frequency	[Hz]	50...60					
Release trip	[V]	0.35 Un ≤ V ≤ 0.7 Un					
Terminals	[mm ²]	2 x 1.5					
Consumption	[mA]	10					
Resistance to corrosion	[°C/RH]	const. climatic cond.: 23/83-40/93-55/20; var. climatic cond.: 25/95-40/93					
Protection degree		IPXXB/IP2X					
Tightening torque	[Nm]	0.4					
Dimensions (WxDxH)	[mm]	17.5x68x90					

S2-S	S2-SH
1 change over	2 change over
	240
	415
	6
	2
250	110
60	60
0.5	1
	1
	4
	12 a.c.-12 d.c.
	12
	up to 2x1.5
	3
	1000 (protected with S 2 breaker characteristic K - 6 A)
	4
	0.7
	8.75x68x90

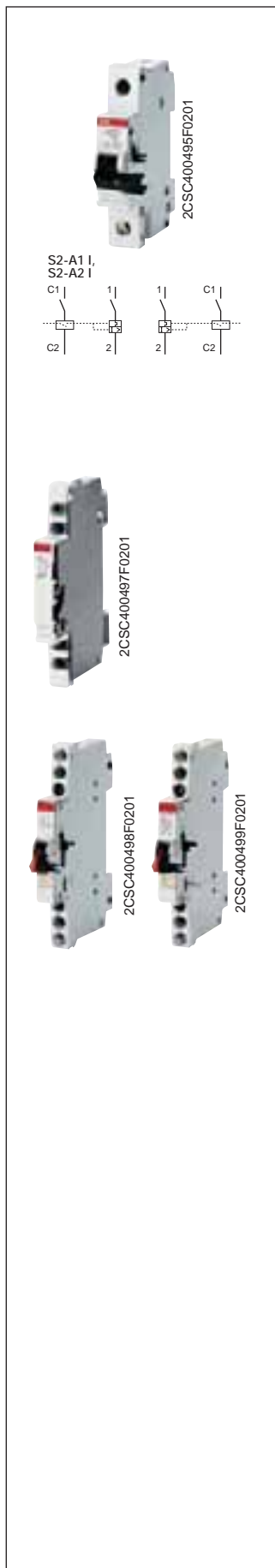

Description	Order details		Bbn 4012233	Price 1 piece	Price group	Weight 1 piece kg	Pack unit pc.
	Type code	Order code					

Shunt trips

Function: remote opening of the device when a voltage is applied
Suitable for MCBs S 280 and S 280 UC series

12-60 VAC/VDC shunt trip	S2-A1	GH S280 1909 R0001	42930 1			0.145	1
110-415 VAC and 110-250 VDC shunt trip	S2-A2	GH S280 1909 R0002	42940 0			0.145	1

Auxiliary contacts

Function: indication of the position of the device's contacts
Suitable for MCBs S 280 and S 280 UC series

Signal contacts

Function: indication of the position of the device's contacts only after the automatic release of the MCBs and RCBOs due to an overload or a short-circuit
Suitable for MCBs S 280 and S 280 UC series

Auxiliary contact 1 NO + 1 NC (1/2 module)	S2-H11	GH S270 1916 R0001	61500 1			0.04	1
Auxiliary contact 2 NO (1/2 module)	S2-H20	GH S270 1916 R0002	61510 0			0.04	1
Auxiliary contact 2 NC (1/2 module)	S2-H02	GH S270 1916 R0003	61520 9			0.04	1
Auxiliary contact 1 NO + 1 NC (1/2 module) with Faston connections	S2-H11X	GH S270 1917 R0001	61530 8			0.04	1
Auxiliary contact 2 NO (1/2 module) with Faston connections	S2-H20X	GH S270 1917 R0002	61540 7			0.04	1
Auxiliary contact 2 NC (1/2 module) with Faston connections	S2-H02X	GH S270 1917 R0003	61550 6			0.04	1
Auxiliary contact 2 NO + 1 NC (1/2 module)	S2-H21	GH S270 1936 R0001	01370 3*			0.05	1
Auxiliary contact 1 NO + 2 NC (1/2 module)	S2-H12	GH S270 1936 R0002	01380 2*			0.05	1
Auxiliary contact 3 NO (1/2 module)	S2-H30	GH S270 1936 R0003	01390 1*			0.05	1
Auxiliary contact 3 NC (1/2 module)	S2-H03	GH S270 1936 R0004	01400 7*			0.05	1
Signal contact (1/2 module)	S2-S	GH S280 1925 R0001	12770 7*			0.07	1
Signal contact + Auxiliary contact (1/2 module)	S2-S/H	GH S280 1901 R0008	42900 4			0.05	1

* Bbn 4016779

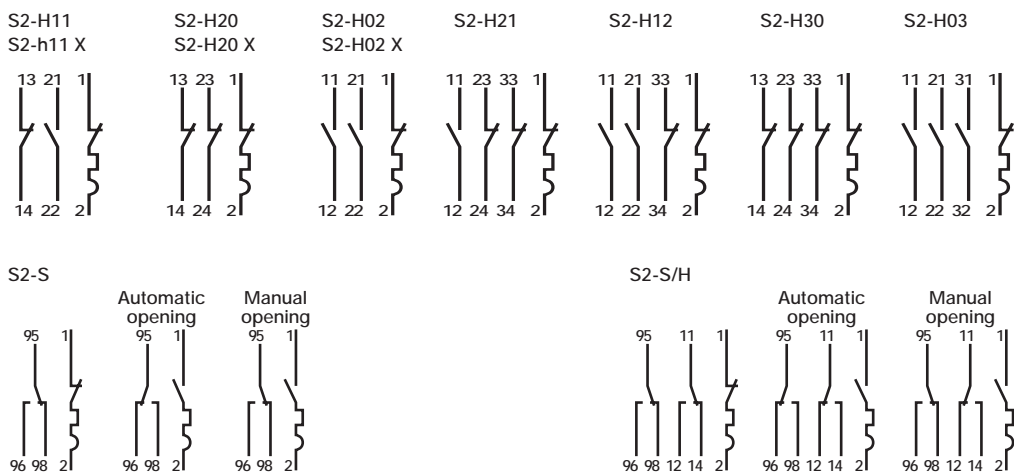

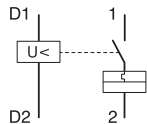

Undervoltage releases

Function: protection of the load in the event of a voltage drop (between 70% and 35% of its rated value); positive safety (device's tripping when the voltage is disconnected) emergency stop by means of a button.

Suitable for MCBs S 280 and S 280 UC series

Undervoltage release 12V DC (1 module)	S2-UA 12	GH S280 1911 R0001 42970 7	0.09	1
Undervoltage release 24V AC/DC (1 module)	S2-UA 24	GH S280 1911 R0002 42980 6	0.09	1
Undervoltage release 48V AC/DC (1 module)	S2-UA 48	GH S280 1911 R0003 79360 0	0.09	1
Undervoltage release 110V AC/DC (1 module)	S2-UA 110	GH S280 1911 R0004 43000 0	0.09	1
Undervoltage release 220V AC/DC (1 module)	S2-UA 220	GH S280 1911 R0005 43010 9	0.09	1
Undervoltage release 380V AC (1 module)	S2-UA 380	GH S280 1911 R0006 79370 9	0.09	1

Hand operated neutral

The hand operated neutral has to be mounted to the left side of the MCB and be snapped on the DIN rail. It is used for measuring duties where the neutral conductor must be in the open position. Due to the special design of the handle - when switching ON the MCB - the neutral will make before the MCB is closed.

The S2C - Nt is not to switch with a tool (screw driver).

Hand operated neutral	S2-NT	GH S270 1908 R0001 36610 1	0.06	1
-----------------------	--------------	-----------------------------------	------	---

Combination between auxiliary elements and S 290

4

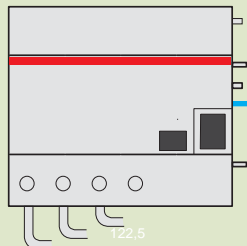

DDA
for
S 290

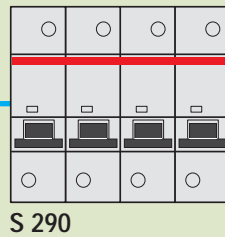

S 290

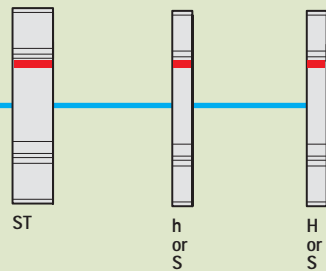
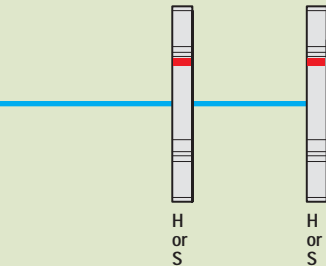
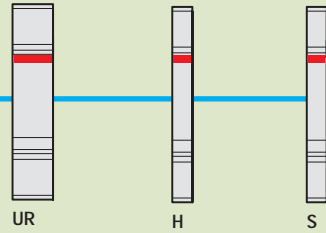

H	Auxiliary contact
S	Signal contact
ST	Shunt trip
UR	Undervoltage release

Technical characteristics of shunt trips

Type		S 290 A1	S 290 A2
Rated voltage	[V] a.c.	110...415	24...48
	d.c.	110...250	24...48
Max. release duration	[ms]	<10	<10
Consumption on release	[VA] a.c.	20...180	40...200
	d.c.	20...180	40...200
Terminals	[mm ²]	25	25
Tightening torque	[Nm]	2	2
Dimensions (WxDxH)	[mm]	17.5x68x90	17.5x68x90

Technical characteristics of auxiliary and signal contacts

Type		S 290 H11 S 290 S
Description		1NO+1NC
Alternating current (AC 13)	Ue [V]	230/400
	Ie [A]	6/2
Direct current (DC 13)	Ue [V]	24/60/110/220
	Ie [A]	6/3/1/1
Min. operating voltage	[V]	12 a.c.-12 d.c.
Min. operating current	[mA]	5
Terminals	[mm ²]	0.5...2.5
Dielectric strength	[kV]	3
Resistance to short-circuit at 240 V a.c.	[A]	1000 (protected with breaker char. K 6 A)
Impulse voltage withstand capacity	[kV]	4
Tightening torque	[Nm]	1
Dimensions (WxDxH)	[mm]	8.75x68x90

Technical characteristics of undervoltage releases

Type		S 290-UA 230
Standards		VDE0660 part I - IEC EN 60947.1
Rated voltage	[V] a.c.	230
	[V] d.c.	-
Frequency	[Hz]	50...60
Release trip threshold	[V]	0.35 Un≤V≤0.7 Un
Terminals	[mm ²]	2x1.5
Consumption	[mA]	10
Resistance to corrosion	[°C/RH]	constant atmosphere: 23/83-40/93-55/20; variable atmosphere: 25/95-40/93
Protection degree		IPXXB/IP2X
Tightening torque	[Nm]	0.4
Dimensions (WxDxH)	[mm]	17.5x68x90



2CSC400496F0201

S 290 A1
S 290 A2

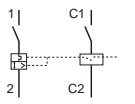

2CSC400500F0201

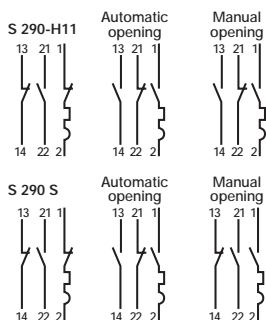

2CSC400397F0201

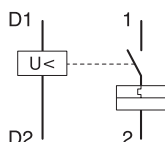

Description	Order details	Bbn	Price	Price group	Weight	Pack unit
	Type code	Order code	1 piece		1 piece	pc.
		EAN			kg	

Shunt trips

Function: remote opening of the device when a voltage is applied
Suitable for MCBs S 290 series

110-415V AC/110 DC shunt trip	S 290 A1	GH S290 1909 R0011	57033 6	0,09	1
24-48V AC/DC	S 290 A2	GH S290 1909 R0012	57034 3	0,09	1

Auxiliary contact

Function: indication of the position of the device's contacts
Suitable for MCBs S 290 series

Signal contact

Function: indication of the position of the device's contacts only after the automatic release of the MCBs and RCBOs due to an overload or a short-circuit
Suitable for MCBs S 290 series

Auxiliary contact 1 NO + 1 NC (1/2 module)	S 290 H11	GH S290 1916 R0011	57031 2	0,05	1
Signal contact (1/2 module)	S 290-S11	GH S290 1902 R0018	57032 9	0,05	1

Undervoltage releases

Function: protection of the load in the event of a voltage drop (between 70% and 35% of its rated value); positive safety (device's tripping when the voltage is disconnected) emergency stop by means of a button.

Suitable for MCBs S 290 series

Undervoltage release DC 24 V	S 290-UA 24	GH S290 1911 R0012	57035 0	0,09	1
Undervoltage release DC 110 V	S 290-UA 110	GH S290 1911 R0014	57036 7	0,09	1
Undervoltage release AC 230 V	S 290-UA 230	GH S290 1911 R0015	57037 4	0,09	1

System pro M compact® Schemes for combination Auxiliary elements and accessories for MCBs S800 series

Combination between auxiliary elements and S800

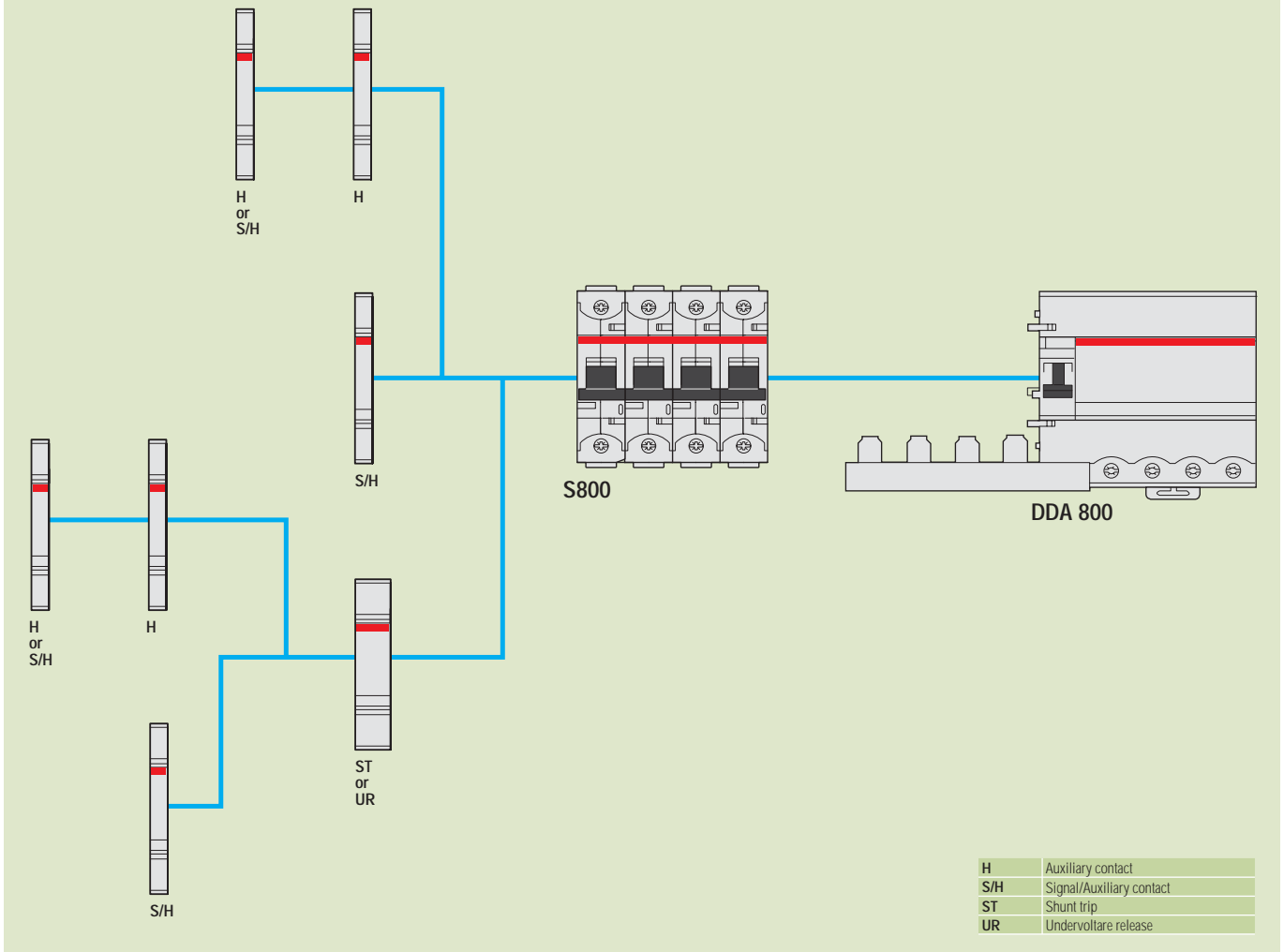

Short circuit limiter S803S-SCL

Max. rated continuous current I_n	[A]	32, 63, 125
Poles		3
Rated operating voltage U_e (AC) 50/60Hz	[V]	400/690
Rated insulation voltage U_i	[V]	690
Rated impulse withstand voltage U_{imp}	[kV]	8
Ultimate short-circuit breaking capacity I_{cu} in accordance with IEC 60947-2		
400VAC	[kA]	100
440VAC	[kA]	100
690VAC	[kA]	50
Valid combination see: http://www.abb.com/product Low Voltage Products and Systems/Modular DIN Rail Products/High Performance Circuit Breakers HPCBs/Software		
Service short-circuit breaking capacity I_{cs} in accordance with IEC 60947-2		100% I_{cu}
Rated frequency	[Hz]	50/60
Mounting position		any
Disconnecter properties according to IEC 60947-2		yes
Standard		IEC 60947-2
Connection Cu (10...32A)	[mm ²]	1...25 strand 1...35 cable
Connection Cu (40...125A)	[mm ²]	6...50 strand 6...70 cable
Tightening torque	[Nm]	min. 3/max. 4
Supply		any
Mounting on DIN top hat rail		EN 60715
Permissible ambient temperature for operations	[°C]	-25...+60
Storage temperature	[°C]	-40...+70
Type of protection		IP20 IP40 (only actuation side)
Classification in accordance with NF-16-101, NF16-102		I3F2
Resistance to vibration		IEC 60068-2-27; IEC 60068-2; EN 61373 Cat.1/ class B

Rated current I_n	Internal resistance R_i	Power loss P_v
[A]	[mΩ]	[W]
32	1.7	1.7
63	1.0	4.0
125	0.6	9.4

Auxiliary contact S800-AUX

Utilisation category		AC15 400/2A AC15 240/6A DC13 250/0.55A DC13 125V/1.1A DC13 60V/2A DC13 24V/4A
Continuous thermal current I_n	[A]	6
Rated insulation voltage U_i	[V]	690
Number of contacts		2
Rated impulse withstand voltage U_{imp}	[kV]	6
Pollution degree		3
Function of contact		Changeover contacts
Connection Cu	[mm ²]	1 x 2.5 2 x 1.5
Tightening torque	[Nm]	1
AC/DC supply		any
Mounting on DIN top hat rail		EN 60715
Type of protection		IP20
Permissible ambient temperature for operations	[°C]	-25...+60
Storage temperature	[°C]	-40...+70
Mech. device service life		6000 switching cycles
I_{cu} with S450E	[A]	1000
Resistance to vibration		IEC 60068-2-6; EN 61373 Cat.1/class B 5g, 20 frequency cycle 5...150...5Hz at 24V AC/DC, 5mA brief interrupt <10ms

Combined auxiliary and signal contact S800 AUX/ALT

Utilisation category		AC15 400/2A AC15 240/6A DC13 250/0.55A DC13 125V/1.1A DC13 60V/2A DC13 24V/4A
Continuous thermal current I_n	[A]	6
Rated insulation voltage U_i	[V]	690
Number of contacts		2 (1x AUX, 1 x AUX/ALT)
Rated impulse withstand voltage U_{imp}	[kV]	6
Pollution degree		3
Function of contact		Changeover contacts
Connection Cu	[mm ²]	1 x 2.5 2 x 1.5
Tightening torque	[Nm]	1
AC/DC supply		any
Mounting on DIN top hat rail		EN 60715
Type of protection		IP20
Permissible ambient temperature for operations	[°C]	-25...+60
Storage temperature	[°C]	-40...+70
Mech. device service life		6000 switching cycles
I_{cu} with S450E	[A]	1000
Resistance to vibration		IEC 60068-2-6; EN 61373 Cat.1/class B 5g, 20 frequency cycle 5...150...5Hz at 24V AC/DC, 5mA brief interrupt <10ms

Shunt Operation Release S800-SOR

		S800-SOR24	S800-SOR130	S800-SOR250	S800-SOR400
Rated voltage Ue	[V AC/DC]	24	48...130	110...250	220...400
Operating range	[%] Ue			70...110	
Rated insulation voltage Ui	[V]			690	
Coil pull in consumption	[W/VA]	16.6	41.9...307.3	23...119	45...148.1
Rated frequency	[Hz]			DC; 50/60	
Pollution degree				3	
Connection Cu	[mm ²]			1...25 strand 1...35 cable	
Tightening torque	[Nm]			min.3/ max.4	
AC/DC supply				any	
DIN top hat rail				EN 60715	
Type of protection				IP20 IP40 (only actuation side)	
Permissible ambient temperature of operations	[°C]			-25...+60	
Storage temperature	[°C]			-40...+70	
Resistance to vibration				IEC 60068-2-6; EN61373 Cat.1/class B	

Undervoltage Release S800-UVR

		S800-UVR36	S800-UVR60	S800-UVR130	S800-UVR250
Rated voltage Ue	[V AC/DC]	24...36	48...60	110...130	220...250
Operating range					
Operating opening	[%] Ue			35...70	
Operating closing	[%] Ue			85	
Rated insulation voltage Ui	[V]			690	
Coil pull in consumption	[W/VA]	1.11...1.14	1.14...1.25	1.3...1.41	1.71...1.91
Rated frequency	[Hz]			DC; 50/60	
Pollution degree				3	
Standard				IEC 60947-5-1	
Connection Cu	[mm ²]			1...25 strand 1...35 cable	
Tightening torque	[Nm]			min.3/ max.4	
AC/DC supply				any	
DIN top hat rail				EN 60715	
Type of protection				IP20 IP40 (only actuation side)	
Permissible ambient temperature of operations	[°C]			-25...+60	
Storage temperature	[°C]			-40...+70	
Resistance to vibration				IEC 60068-2-6; EN61373 Cat.1/class B	

Bus-bar S803-BB250

Max. rated continuous current In		
Side supply	[A]	125
Central supply	[A]	250
Conditional short circuit current Ip [kA eff]	100 protected by Tmax	
Poles	3	
Rated operating voltage Ue		
(AC) 50/60Hz	[V]	400/690
Rated insulation voltage Ui	[V]	690
Rated impulse withstand voltage Uimp	[kV]	8
Rated frequency	[Hz]	50
Standards	EN 60439-2:2000	
Material of the bars	E-Cu 58 half-hard rolled F25	
Material of the insulation profile	Cycoloy C 3600; UL94 V-0 at 1.5mm	
Material of the end caps	Polyamide PA66+PA6; UL94 V-0 at 0.4mm Free of halogen and phosphorus	
Busbar cross-sections	[mm ²]	60
Overvoltage category	III	
Pollution degree	2	

Bus-bar Power Connector S803-BBPC120

Max. rated continuous current In [A]	250	
Poles	3	
Rated operating voltage Ue [V]	400/690	
Rated frequency [Hz]	50	
Standards	EN 60439-2:2000	
Material of the terminals	CuZn39Pb2; material no.:2.0380	
Casing material	Polyamide PA66+PA6; UL94 V-0 at 0.4mm Free of halogen and phosphorus	
Tightening torque		
At supply end	[Nm]	19
At busbar end	[Nm]	3
Connection cross-section	[mm ²]	120
Pollution degree	2	



Description	Order details	Bbn	Price	Price group	Weight	Pack unit
[A]	Type code	Order code	1 piece		1 piece	pc.
			EAN		kg	

Short-circuit current limiters with cage terminal

32	S 803S-SCL32	2CCS800900R0291	208912		0.735	1
63	S 803S-SCL63	2CCS800900R0301	208929		0.735	1
125	S 803S-SCL125	2CCS800900R0281	208905		0.735	1

Short-circuit current limiters with ring terminal cable connection

63	S 803S-SCL63-R	2CCS800900R0331	208950		0.735	1
125	S 803S-SCL125-R	2CCS800900R0311	208936		0.735	1

Description	Order details	Bbn	Price	Price group	Weight	Pack unit
	Type code	Order code	1 piece		1 piece	pc.
			EAN		kg	

Auxiliary contact

Auxiliary contact	S 800-AUX	2CCS800900R0011	206802		0.049	1
-------------------	-----------	-----------------	--------	--	-------	---

Combined auxiliary and signal contact

Auxiliary/signal contact	S 800-AUX/ALT	2CCS800900R0021	206819		0.050	1
--------------------------	---------------	-----------------	--------	--	-------	---

Separating neutral

Separating neutral 63A	S 800-NT	2CCS800900R0061	208196		0.115	1
------------------------	----------	-----------------	--------	--	-------	---



Description	Order details		Bbn	Price	Price	Weight	Pack
	Type code	Order code	7612271	1 piece	group	1 piece	unit
			EAN			kg	pc.

Shunt operation releases

24VAC/DC	S800-SOR24	2CCS800900R0191	208318			0.15	1
48...130VAC/DC	S800-SOR130	2CCS800900R0221	208349			0.15	1
110...250VAC/DC	S800-SOR250	2CCS800900R0211	208332			0.15	1
220...400VAC/DC	S800-SOR400	2CCS800900R0231	208356			0.15	1

Under voltage releases

24...36VAC/DC	S800-UVR36	2CCS800900R0241	208363			0.15	1
48...60VAC/DC	S800-UVR60	2CCS800900R0251	208370			0.15	1
110...130VAC/DC	S800-UVR130	2CCS800900R0261	208387			0.15	1
220...250VAC/DC	S800-UVR250	2CCS800900R0271	208394			0.15	1

Rotary drive adapter for 3-4-pole High Performance MCB

Rotary Drive	S 800-RD	2CCS800900R0041	208172			0.080	1
--------------	-----------------	-----------------	---------------	--	--	-------	---

Description	Order details		Bbn	Price	Price	Weight	Pack
	Type code	Order code	8015644	1 piece	group	1 piece	unit
			EAN			kg	pc.

Anthracite/Standard rotary handle for door assembly

Anthracite rotary handle	S 800-RHE-H	1SDA060150R1	625771			0.21	1
--------------------------	--------------------	--------------	---------------	--	--	------	---

Red/Emergency rotary handle for door assembly

Red rotary handle	S 800-RHE-H-EM	1SDA060151R1	625764			0.21	1
-------------------	-----------------------	--------------	---------------	--	--	------	---

Axial extension of rotary drive – rotary handle 500mm

Rod 500mm for RHE	S 800-RHE-S	1SDA060179R1	626242			0.19	1
-------------------	--------------------	--------------	---------------	--	--	------	---

IP54 protection for rotary handle

IP54 kit	S 800-RHE-IP54	1SDA060180R1	626259			0.075	1
----------	-----------------------	--------------	---------------	--	--	-------	---

Description	Order details		Bbn	Price	Price	Weight	Pack
	Type code	Order code	7612271	1 piece	group	1 piece	unit
			EAN			kg	pc.

Intermediate piece

Intermediate Piece 9mm	S 800-IP9	2CCS800900R0031	208202			0.011	1
------------------------	------------------	-----------------	---------------	--	--	-------	---

Padlock device

Padlock Lever Lock with 4mm hasp	S 800-PLL	2CCS800900R0051	208189			0.0015	1
----------------------------------	------------------	-----------------	---------------	--	--	--------	---



Interchangeable adapter kit

Cage Terminal	S 800-CT2125	2CCS800900R0181	208264	0.034	2
Cage Terminal	S 800-CT4125	2CCS800900R0151	208233	0.068	4
Cage Terminal	S800-CT232	2CCS800900R0451	208257	0.03	2
Cage Terminal	S800-CT432	2CCS800900R0441	208226	0.06	4
Cage Terminal	S800-CT2125	2CCS800900R0181	208264	0.03	2
Cage Terminal	S800-CT4125	2CCS800900R0151	208233	0.06	4
Cage Terminal	S800N-CT232	2CCS800900R0451	212025	0.03	2
Cage Terminal	S800N-CT432	2CCS800900R0441	212018	0.06	4
Cage Terminal	S800N-CT2125	2CCS800900R0471	212049	0.03	2
Cage Terminal	S800N-CT4125	2CCS800900R0461	212032	0.06	4

Interchangeable adapter kit

Ring Terminal cable connection	S 800-RT2125	2CCS800900R0161	208240	0.03	2
Ring Terminal cable connection	S 800-RT4125	2CCS800900R0131	208219	0.06	4
Ring Terminal cable connection	S800-RT232	2CCS800900R0431	211981	0.03	2
Ring Terminal cable connection	S800-RT432	2CCS800900R0421	211974	0.06	4
Ring Terminal cable connection	S800-RT2125	2CCS800900R0161	208240	0.03	2
Ring Terminal cable connection	S800-RT4125	2CCS800900R0131	208219	0.06	4
Ring Terminal cable connection	S800N-RT232	2CCS800900R0491	212001	0.03	2
Ring Terminal cable connection	S800N-RT432	2CCS800900R0481	211998	0.06	4
Ring Terminal cable connection	S800N-RT2125	2CCS800900R0391	210878	0.03	2
Ring Terminal cable connection	S800N-RT4125	2CCS800900R0401	210861	0.06	4

Busbar

Busbar 250A	S 803-BB250	2CCS800900R0071	208288	1.5	1
-------------	-------------	-----------------	--------	-----	---

Supply block

Busbar Power Connector 120mm ²	S 803-BBPC120	2CCS800900R0101	208301	0.46	1
---	---------------	-----------------	--------	------	---

Contact protection cap

Busbar Isolation Cap	S 800-BBIC	2CCS800900R0081	208967	0.02	12
----------------------	------------	-----------------	--------	------	----

End cap

End cap	S 800-END	2CCS800900R0091	208295	0.04	1
---------	-----------	-----------------	--------	------	---

Pole connector

Pole connector 125A	S802-LINK125	2CCS800900R0411	211295	0.03	3
---------------------	--------------	-----------------	--------	------	---

S 800-ILS

Identification Labeling System 168x6x11.5mm	S 800-ILS	2CCS800900R0121	208271	0.011	1
---	-----------	-----------------	--------	-------	---

Auxiliary elements and accessories for DDA 800 RCD-blocks

Description	Order details	Bbn	Price	Price group	Weight	Pack unit
	Type code	Order code	1 piece		1 piece	
		EAN			kg	pc.
Ring tongue terminal kit	DDA 800-RT	2CSB100913R0001	987406		0.01	1/12

Surge Protective Devices (SPDs) are aimed at protecting electrical and electronic equipment against overvoltages and impulse currents (such as switching and lightning surges). To do so, the SPDs feature the following two functions:

- they limit overvoltage to a level acceptable by the equipment to be protected.
- they divert surge currents.

SPDs are divided in the following families:

- **Type 1 SPDs** are lightning current arresters: they are designed to discharge high energy from lightning impulse while ensuring equipotential bonding in case of direct lightning stroke on the installation. They are recommended for installations exposed to direct lightning (such as installations protected by external lightning protection systems or powered by aerial lines). They are installed at the entrance of the installation (such as main distribution board).

- **Type 2 SPDs** are surge arresters: they are designed to discharge lower energies from distant lightning strokes or from switching operations. They can not handle high energies from lightning impulses as SPDs Type 1 do, but on the other hand they offer a better voltage protection level. Type 2 SPDs are recommended at the entrance of installations with no exposure to direct lightning. Whether Type 1 or Type 2 is installed at the entrance of the installation, additional Type 2 SPDs are installed as close as possible to the equipment to protect, in sub-distribution boards for instance.

- **Type 1+2 SPDs** combine together Type 1 and Type 2 SPDs already coordinated. They can handle high energies from direct lightning strokes and ensure a low voltage protection level suitable for protection of most of electrical and electronic equipment.

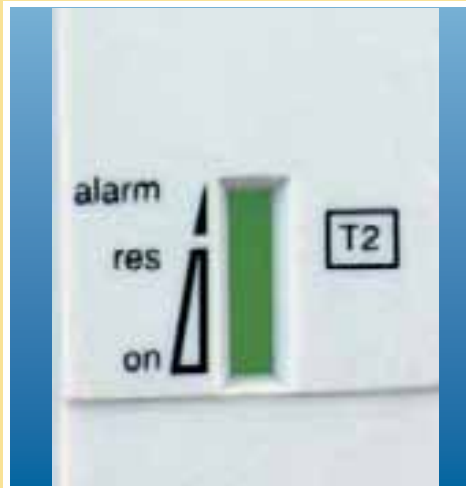

2CSC400557F0201



2CSC400558F0201



2CSC400560F0201



2CSC400559F0201

- In addition to the standard SPDs, all the range can be delivered with remote indication (TS) and Type 2 SPDs can be proposed

with optional safety reserve to ensure a preventive maintenance of the installation. All these SPDs comply with

the international standard IEC 61643-1 and the European standard EN 61643-11.



Other modular devices Surge Protective Devices OVR range

Index

Technical features of SPDs	5/2
Selection tables of SPDs	5/6



System Technical features

pro M compact® OVR Surge Protective Devices

Type 1 & Type 1+2

SPDs



TECHNICAL FEATURES		Type 1 OVR T1 ■ 25 ■ TS				
Technology		Triggered spark-gap				
Electrical features		IEC 61643-1 / EN 61643-11				
Standard		1 / I				
Type / test class		1P ■ 2P ■ 2L ■ 3P ■ 3L ■ 4P ■ 4L ■				
Poles		1P+N ■ 1N ■ 3P+N ■ 3N ■				
Types of networks		IT - TNS - TNC TNS - TNC TT TT				
Type of current		A.C.				
Nominal voltage Un	V	400	230	230	230	230
Max. cont. operating voltage Uc	V	440	255	-	-	-
Max. cont. operating voltage Uc (L-N / N-⊥)	V	-	-	255 / 255	255 / 255	255 / 255
Impulse current Iimp (10/350) per pole	kA	25	25	-	-	-
Impulse current Iimp (10/350) (L-N / N-⊥)	kA	-	-	25 / 50	25 / 100	25 / 100
Nominal discharge current In (8/20) per pole	kA	25	25	-	-	-
Nominal discharge current In (8/20) (L-N / N-⊥)	kA	-	-	25 / 50	25 / 100	25 / 100
Voltage protection level Up	kV	2	2.5	-	-	-
Voltage protection level Up (L-N / N-⊥)	kV	-	-	2.5 / 1.5	2.5 / 1.5	2.5 / 1.5
Follow current interrupting rating If _i	kArms	50	50	-	-	-
Follow current interrupting rating If _i (L-N / N-⊥)	kArms	-	-	50 / 0.1	50 / 0.1	50 / 0.1
TOV (Temporary overvoltage) withstand U _T (5s.)	V	690	400	-	-	-
TOV (Temporary overvoltage) withstand U _T (L-N: 5s. / N-⊥ : 200ms.)	V	-	-	400 / 1200	400 / 1200	400 / 1200
Continuous operating current I _c	mA	None				
Short-circuit withstand capability	kArms	50				
Load current I _{load} (for V-wiring)	A	125				
Maximum back-up fuse gG/gL						
Parrallel Connection	A	125				
Serial Connection (V-wiring)	A	125				
Mechanical features						
Stocking and operating temperature	°C	-40 to +80				
Degree of protection		IP 20				
Fire resistance according to UL 94		V0				
Colour of Housing		Polyarylamide grey RAL 7035				
State indicator		Option (with TS)				
TS remote indicator		Option (TS)				
Installation						
Wire range (L, N, ⊥)						
solid wire	mm ²	2.5 ... 50				
stranded wire	mm ²	2.5 ... 35				
Stripping length (L, N, ⊥)	mm	15				
Tightening torque (L, N, ⊥)	Nm	3.5				

TECHNICAL FEATURES OF THE INTEGRATED AUXILIARY CONTACT (TS)

Electrical features			
Contact complement		1NO (1 normally open contact), +1NC (1 normally closed contact)	
Min. load		6V D.C. - 10 mA	
Max. load		250V A.C. - 5 A	
Continuous operating current	mA	10	
Installation			
Connection cross-section	mm ²	1.5	

System pro M compact® OVR Surge Protective Devices Type 1 & Type 1+2

SPDs



Type 1 OVR T1 25 255-7 Triggered spark-gap	Type1+2 OVR T1+2 25 255 TS Triggered spark-gap/varistor	Type 1+2 OVR T1+2 15 255-7 Triggered spark-gap	Type 1+2 OVR T1+2 7 275 s P Varistor
IEC 61643-1 / EN 61643-11 1 / I	IEC 61643-1 / EN 61643-11 1 / I	IEC 61643-1 / EN 61643-11 1 / I	IEC 61643-1 / EN 61643-11 1 / I
1P 1 3P+N 3N		1P 1 3P+N 3N	1P 1, 3P 3L, 4P 4L 1P+N 1N 3P+N 3N
TNS - TNC TT	TNS - TNC - TT	TNS - TNC TT	TNS - TNC TT TT
A.C. 230	A.C. 230	A.C. 230	A.C. 230
255 - - 255 / 255	255 - -	255 - - 255 / 255	275 - - 275
25 - - 25 / 100	25 - -	15 - - 15 / 50	7 - - 7 / 12
25 - - 25 / 100	25 - -	15 - - 15 / 50	6 - - 6
2.5 - - 2.5 / 1.5	1.5 - -	1.5 - - 1.5 / 1.5	0.9 - - 0.9 / 1.4
7 - - 7 / 0.1	15 - -	7 - - 7 / 0.1	NA - - NA / 0.1
650 - - 650 / 1200	334 - -	650 - - 650 / 1200	334 - - 334 / 1200
< 2 (LED)	< 1 (Varistor leakage)	< 2 (LED)	< 1
50 - -	50 - 125	50 - -	50 - -
125 - NA	125 - 125	125 - NA	32 - NA
-40 to +80	-40 to +80	-40 to +80	-40 to +80
IP 20	IP 20	IP 20	IP 20
V0	V0	V0	V0
Polyarylamide grey RAL 7035	Polyarylamide grey RAL 7035	Polyarylamide grey RAL 7035	PC grey RAL 7035
Yes	Yes	Yes	Yes
No	Yes	No	No
2.5 ... 50	2.5 ... 50	2.5 ... 50	2.5 ... 25
2.5 ... 35	2.5 ... 35	2.5 ... 35	2.5 ... 16
15	15	15	12.5
3.5	3.5	3.5	2.8
-	1NO (1 normally open contact), +1NC (1 normally closed contact)	-	-
-	12V D.C. - 10 mA	-	-
-	250V A.C. - 1 A	-	-
-	None	-	-
-	1.5	-	-

5

System **pro M compact**® Technical features

OVR Surge Protective Devices Type 2

SPDs



TECHNICAL FEATURES

OVR T2 ■ ■ ■ (s) P (TS)

		Varistor								
Technology										
Electrical features		IEC 61643-1 / EN 61643-11								
Standard		2 / II								
Type / test class										
Poles		1P ■			1P ■ , 3P ■ , 4P ■			1P+N ■ , 3P+N ■		
Types of networks		IT			TNS - TNC			TT		
Type of current		A.C.								
Nominal voltage Un		V 400			V 230			V 230		
Max. cont. operating voltage Uc		V 440			V 275			-		
Max. cont. operating voltage Uc (L-N / N-⊥)		V -			V -			V 275 / 255		
Maximum discharge current I _{max} (8/20) per pole		kA 15 40 70			kA 15 40 70			-		
Maximum discharge current I _{max} (8/20) (L-N / N-⊥)		kA -			kA -			kA 15/70 40/70 70/70		
Nominal discharge current I _n (8/20) per pole		kA 5 20 30			kA 5 20 30			-		
Nominal discharge current I _n (8/20) (L-N / N-⊥)		kA -			kA -			kA 5/30 20/30 30/30		
Voltage protection level U _p		kV 1.5 1.9 2			kV 1 1.4 1.5			-		
Voltage protection level U _p (L-N / N-⊥)		kV -			kV -			kV 1/1.4 1.4/1.4 1.5/1.4		
Follow current interrupting rating I _f		kArms NA			kArms NA			-		
Follow current interrupting rating I _f (L-N / N-⊥)		kArms -			kArms -			kArms NA / 0.1		
TOV (Temporary overvoltage) withstand U _T (5s.)		V 440 440 440			V 334			-		
TOV (Temporary overvoltage) withstand U _T (L-N: 5s. / N-⊥ : 200ms.)		V -			V -			V 334 / 1200		
Continuous operating current I _c		mA < 1			mA < 1			mA < 1		
Short-circuit withstand capability		kArms 50			kArms 50			kArms 50		
Disconnecter										
gG -gL fuse		A 32			A 32			A 32		
curve C circuit breaker		A 40			A 40			A 40		
Mechanical features										
Stocking and operating temperature		°C -40 to +80								
Degree of protection		IP 20								
Fire resistance according to UL 94		V0								
Material of Housing		PC grey RAL 7035								
Pluggable cartridge		Yes								
Integrated thermal disconnecter		Yes								
State indicator		Yes								
Safety reserve		Option (s)								
TS remote indicator		Option (TS)								
Installation										
Wire range (L, N, ⊥)										
solid wire		mm ²			mm ² 2.5 ... 25					
stranded wire		mm ²			mm ² 2.5 ... 16					
Stripping length (L, N, ⊥)		mm			mm 12.5					
Tightening torque (L, N, ⊥)		Nm			Nm 2.8					

TECHNICAL FEATURES OF THE INTEGRATED AUXILIARY CONTACT (TS)

Electrical features			
Contact complement		1NO (1 make contact), +1NC (1 normally closed contact)	
Min. load		12V D.C. - 10 mA	
Max. load		250V A.C. - 1 A	
Continuous operating current		mA None	
Installation			
Connection cross-section		mm ² 1.5	

System *pro M compact*® Technical features

OVR Surge Protective Devices Type 2



OVR T2 ■ ■ 275 Varistor	OVR PV ■ ■ P (TS) Varistor	OVR TC ... P
IEC 61643-1 / EN 61643-11	IEC 61643-1 / EN 61643-11	IEC 61643-21
2 / II	2 / II	TC
1P ■ , 3P ■ ■ , 4P ■ ■ ■ 3P+N ■ ■	■ ■	1 pair
TNS - TNC - TT	PV Systems	Dateline / Telecom
A.C.	D.C.	Low current
230	80	6 12 24 48 200 200
275	106	7 14 27 53 220 220
- - 275 / 440	30 65	-
15 40 -	40 40	10
- - 40 / 70	- -	-
5 20 -	10 20 20 20	5
- - 20 / 30	- -	-
1 1.4 -	- -	15 20 35 70 700 300
- - 1.4 / 1.4	0.3 / 0.6 2.8 / 1.4 3.8	-
NA	- -	-
-	- -	-
334	- -	-
-	- -	-
< 1	< 1 < 1 < 1	140
50	- -	-
-	- -	-
32	- -	-
40	- -	-
-40 to +80	-40 to +80	-40 to +80
IP 20	IP 20	IP 20
V0	V0	V0
PC grey RAL 7035	PC grey RAL 7035	PC grey RAL 7035
No	Yes	Yes
Yes	Yes	Yes Yes Yes Yes No Yes
Yes	Yes	No
No	Option (s)	No
No		No
2.5 ... 25	2.5 ... 25	0.5 ... 2.5
2.5 ... 16	2.5 ... 16	0.5 ... 2.5
12.5	12.5	-
2.8	2.8	-
-	1NO (1 make contact), +1NC (1 normally closed contact)	-
-	12V D.C. - 10 mA	-
-	250V A.C. - 1 A	-
-	None	-
-	1.5	-

T1

Surge Protective Devices, Type 1 / Type 1+2

Function: Type 1 and Type 1+2 SPDs are Lightning Current Arresters. They can handle and divert high energy from lightning.

They are necessary when the installation is exposed to direct lightning (for example when the building is equipped with external lightning protection system or powered by aerial lines). They shall be installed at the line entrance of the installation (meter board or main distribution board).

ABB Type 1 and Type 1+2 SPDs are tested with wave-shape 10/350. Additionally, Type 1+2 SPDs are also tested with wave-shape 8/20 to guarantee protection against overvoltage of low energy from remote lightning stroke or from switching operations.

ABB Type 1+2 SPDs feature a better voltage protection level (Up) than Type 1 SPDs which make them suitable for protection of most of electrical and electronic equipment situated within the protective distance (up to 30 meters).

Type 1 Neutral SPDs are for TT networks when used in combination with phase SPDs Type 1 or Type 1+2.

Application: residential, commercial, industrial

Standard: IEC 61643-1 / EN 61643-11

10/350 current wave for SPDs Type 1, 10/350 & 8/20 for SPDs Type 1+2, spark-gap technology (no blow-out).

Nb. of poles	Impulse current (10/350) kA	Follow current interrupting If _i kArms	Voltage protection level Up kV	Nominal voltage Un V	Max. cont. operating voltage Uc V	Order details voltage	Bbn	Price	Price group	Weight	Pack
						Type code	Order code	EAN		kg	pc.

Type 1 (If_i = 50 kA)

TNS, TNC

1	25	50	2.5	230	255	OVR T1 25 255	2CTB815101R0100	510877		0.25	1
---	----	----	-----	-----	-----	---------------	-----------------	--------	--	------	---

IT (230 / 400 V) & TNS, TNC (400 / 690 V)

1	25	50	2	400	440	OVR T1 25 440-50	2CTB815101R9300	514929		0.27	1
---	----	----	---	-----	-----	------------------	-----------------	--------	--	------	---

TNS (1 Ph+N)

2	25 ⁽²⁾	50	2.5	230	255	OVR T1 2L 25 255	2CTB815101R1200	510891		0.50	1
2	25 ⁽²⁾	50	2.5	230	255	OVR T1 2L 25 255 TS ⁽³⁾	2CTB815101R1100	510945		0.60	1

TT (1 Ph+N)

1+N	25/50 ⁽¹⁾	50/0.1 ⁽¹⁾	2.5/1.5 ⁽¹⁾	230	255/255 ⁽¹⁾	OVR T1 1N 25 255	2CTB815101R1500	510921		0.50	1
1+N	25/50 ⁽¹⁾	50/0.1 ⁽¹⁾	2.5/1.5 ⁽¹⁾	230	255/255 ⁽¹⁾	OVR T1 1N 25 255 TS ⁽³⁾	2CTB815101R1000	510976		0.60	1

TNC

3	25 ⁽²⁾	50	2.5	230	255	OVR T1 3L 25 255	2CTB815101R1300	510907		0.75	1
3	25 ⁽²⁾	50	2.5	230	255	OVR T1 3L 25 255 TS ⁽³⁾	2CTB815101R0600	510952		0.85	1

TNS (3 Ph+N)

4	25 ⁽²⁾	50	2.5	230	255	OVR T1 4L 25 255	2CTB815101R1400	510914		1.00	1
4	25 ⁽²⁾	50	2.5	230	255	OVR T1 4L 25 255 TS ⁽³⁾	2CTB815101R0800	510969		1.10	1

TT (3 Ph+N)

3+N	25/100 ⁽¹⁾	50/0.1 ⁽¹⁾	2.5/1.5 ⁽¹⁾	230	255/255 ⁽¹⁾	OVR T1 3N 25 255	2CTB815101R1600	510938		1.00	1
3+N	25/100 ⁽¹⁾	50/0.1 ⁽¹⁾	2.5/1.5 ⁽¹⁾	230	255/255 ⁽¹⁾	OVR T1 3N 25 255 TS ⁽³⁾	2CTB815101R0700	510983		1.10	1

(1) L-N / N-⊥.

(2) per pole.

(3) TS: tele-signal contact for remote control of the status of the Surge Protective Device.

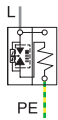

2CSC400306F0201

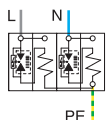

2CSC400315F0201

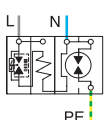

2CSC400315F0201

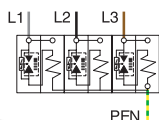

2CSC400316F0201



2CSC400313F0201

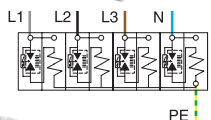

2CSC400313F0201



2CSC400313F0201

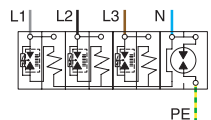

2CSC400313F0201

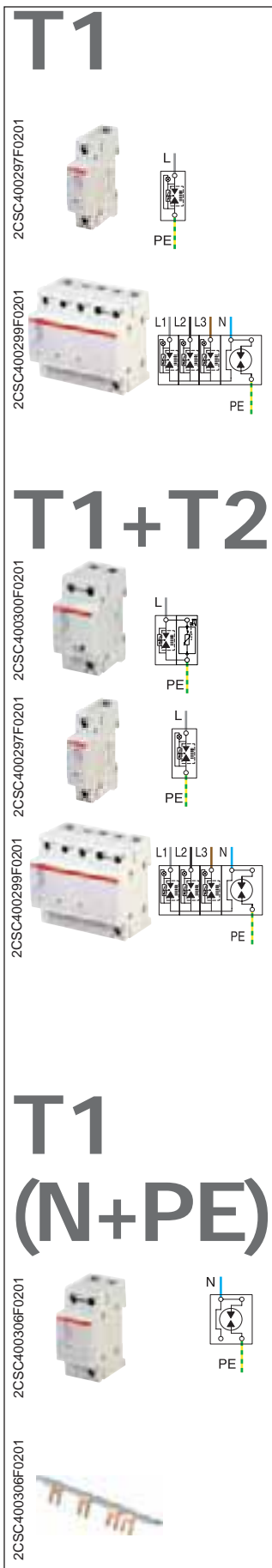

Nb. of poles	Impulse current limp (10/350) kA	Follow current interrupting I_f kArms	Voltage protection Up kV	Nominal level Un V	Max. cont. operating voltage Uc V	Order details voltage	Bbn	Price	Price group	Weight	Pack
						Type code	Order code	EAN		kg	pc.

Type 1 (I_{fi} = 7 kA)

TNS, TNC

1	25	7	2.5	230	255	OVR T1 25 255-7	2CTB815101R8700	514110		0.12	1
---	----	---	-----	-----	-----	-----------------	-----------------	--------	--	------	---

TT (3 Ph+N)

3+N	25/100 ⁽¹⁾	7/0.1 ⁽¹⁾	2.5/1.5 ⁽¹⁾	230	255/255 ⁽¹⁾	OVR T1 3N 25 255-7	2CTB815101R8800	514127		0.60	1
-----	-----------------------	----------------------	------------------------	-----	------------------------	--------------------	-----------------	--------	--	------	---

5

Type 1+2 (I_{imp} = 25 kA)

TNS, TNC, TT

1	25	15	1.5	230	255	OVR T1+2 25 255 TS ⁽³⁾	2CTB815101R0300	510884		0.30	1
---	----	----	-----	-----	-----	-----------------------------------	-----------------	--------	--	------	---

Type 1+2 (I_{imp} = 15 kA)

TNS, TNC

1	15	7	1.5	230	255	OVR T1+2 15 255-7	2CTB815101R8900	514134		0.12	1
---	----	---	-----	-----	-----	-------------------	-----------------	--------	--	------	---

TT (3 Ph+N)

3+N	15/50 ⁽¹⁾	7/0.1 ⁽¹⁾	1.5/1.5 ⁽¹⁾	230	255/255 ⁽¹⁾	OVR T1+2 3N 15 255-7	2CTB815101R9000	514141		0.60	1
-----	----------------------	----------------------	------------------------	-----	------------------------	----------------------	-----------------	--------	--	------	---

Type 1+2 (I_{imp} = 7 kA)

1	7	0	0.9	230	275	OVR T1+2 7 275s P	2CTB815101R3900	513403		0.12	1
2	7	0	0.9/1.4	230	275	OVR T1+2 1N 7 275s P	2CTB815302R1000	515728		0.27	1
4	7	0	0.9/1.5	230	275	OVR T1+2 3N 7 275s P	2CTB815502R1000	515735		0.5	1
3	7	0	0.9	230	275	OVR T1+2 3L 7 275s P	2CTB815101R4000	513410		0.4	1
4	7	0	0.9	230	275	OVR T1+2 4L 7 275s P	2CTB815101R4100	513427		0.5	1
-	7	0	0.9	230	275	OVR T1+2 7 275s C	2CTB815101R3800	513458		0.1	1
-	7	0	1.4	230	275	OVR T1+2 70 NC	2CTB815101R5100	515742		0.05	1

Type 1 Neutral

For TT networks when used in combination with phase SPDs Type 1 or Type 1+2

1	50	0.1	1.5	-	255	OVR T1 50 N	2CTB815101R0400	510853		0.25	1
1	100	0.1	1.5	-	255	OVR T1 100 N	2CTB815101R0500	510860		0.25	1

(1) L-N / N-PE.

(3) TS: telesignal contact for remote control of the status of the Surge Protective Device.

Bus bar

For TT (3Ph+N) networks, this bus bar can be used to connect four single pole Type 1 & Type 1+2 SPDs (except for Type 1 with I_{fi} = 7 kA)

-	-	-	-	-	-	Bus bar 3N	2CTB815102R0400	516091		0.005	50
---	---	---	---	---	---	------------	-----------------	--------	--	-------	----

T2

Surge Protective Devices, Type 2

Function: Type 2 SPDs are surge arresters. They can handle energy from distant/ indirect lightning strikes or from switching operations. Type 2 SPDs can not discharge high energies from direct lightning like Type 1 SPDs but they feature lower protection level (Up). They are recommended at the incoming of installation for locations with no exposure to direct lightning impulses.

Application: residential, commercial, industrial

Standard: IEC 61643-1 / EN 61643-11

8/20 current wave, varistor technology.

Nb. of poles	Maxi. discharge current I _{max} (8/20) kA	Nominal discharge current I _n (8/20) kA	Voltage protection level Up kV	Nom. voltage Un V	Max. cont. operating voltage Uc V	Order details	Bbn 3660308	Price 1 piece	Price group	Weight 1 piece	Pack unit
						Type code	Order code	EAN		kg	ppc.

Type 2 (pluggable)

TNS, TNC

1	15	5	1.0	230	275	OVR T2 15 275 P	2CTB803851R2400	512840		0.12	1
1	40	20	1.4	230	275	OVR T2 40 275 P	2CTB803851R2300	512833		0.12	1
1	40	20	1.4	230	275	OVR T2 40 275s P	2CTB803851R2000	512826		0.12	1
1	40	20	1.4	230	275	OVR T2 40 275 P TS	2CTB803851R1700	514363		0.14	1
1	40	20	1.4	230	275	OVR T2 40 275s P TS ⁽³⁾	2CTB803851R1400	512802		0.15	1
1	70	30	1.5	230	275	OVR T2 70 275 s P	2CTB803851R1900	512819		0.12	1
1	70	30	1.5	230	275	OVR T2 70 275s P TS ⁽³⁾	2CTB803851R1300	512796		0.15	1

IT (230 / 400 V)

1	15	5	1.5	400	440	OVR T2 15 440 P	2CTB803851R1100	512772		0.12	1
1	40	20	1.9	400	440	OVR T2 40 440 P	2CTB803851R1200	512789		0.12	1
1	40	20	1.9	400	440	OVR T2 40 440 s P	2CTB803851R0800	512765		0.12	1
1	40	20	1.9	400	440	OVR T2 40 440 P TS	2CTB803851R0500	514370		0.14	1
1	40	20	1.9	400	440	OVR T2 40 440s P TS ⁽³⁾	2CTB803851R0200	512741		0.15	1
1	70	30	2	400	440	OVR T2 70 440 s P	2CTB803851R0700	512758		0.12	1
1	70	30	2	400	440	OVR T2 70 440s P TS ⁽³⁾	2CTB803851R0100	512734		0.15	1

TT (1 Ph+N)

1+N	15/70 ⁽¹⁾	5/30 ⁽¹⁾	1.0/1.4 ⁽¹⁾	230	275/255 ⁽¹⁾	OVR T2 1N 15 275 P	2CTB803952R1200	513106		0.22	1
1+N	40/70 ⁽¹⁾	20/30 ⁽¹⁾	1.4/1.4 ⁽¹⁾	230	275/255 ⁽¹⁾	OVR T2 1N 40 275 P	2CTB803952R1100	513250		0.27	1
1+N	40/70 ⁽¹⁾	20/30 ⁽¹⁾	1.4/1.4 ⁽¹⁾	230	275/255 ⁽¹⁾	OVR T2 1N 40 275s P	2CTB803952R0800	513090		0.27	1
1+N	40/70 ⁽¹⁾	20/30 ⁽¹⁾	1.4/1.4 ⁽¹⁾	230	275/255 ⁽¹⁾	OVR T2 1N 40 275 P TS	2CTB803952R0500	514387		0.27	1
1+N	40/70 ⁽¹⁾	20/30 ⁽¹⁾	1.4/1.4 ⁽¹⁾	230	275/255 ⁽¹⁾	OVR T2 1N 40 275s P TS ⁽³⁾	2CTB803952R0200	513076		0.27	1
1+N	70/70 ⁽¹⁾	30/30 ⁽¹⁾	1.5/1.4 ⁽¹⁾	230	275/255 ⁽¹⁾	OVR T2 1N 70 275 s P	2CTB803952R0700	513083		0.27	1
1+N	70/70 ⁽¹⁾	30/30 ⁽¹⁾	1.5/1.4 ⁽¹⁾	230	275/255 ⁽¹⁾	OVR T2 1N 70 275s P TS ⁽³⁾	2CTB803952R0100	513069		0.27	1

TNC

3	15 ⁽²⁾	5 ⁽²⁾	1.0	230	275	OVR T2 3L 15 275 P	2CTB803853R3400	512987		0.35	1
3	40 ⁽²⁾	20 ⁽²⁾	1.4	230	275	OVR T2 3L 40 275 P	2CTB803853R2400	513366		0.35	1
3	40 ⁽²⁾	20 ⁽²⁾	1.4	230	275	OVR T2 3L 40 275sP	2CTB803853R2200	512963		0.35	1
3	40 ⁽²⁾	20 ⁽²⁾	1.4	230	275	OVR T2 3L 40 275 P TS	2CTB803853R2500	514400		0.40	1
3	40 ⁽²⁾	20 ⁽²⁾	1.4	230	275	OVR T2 3L 40 275s P TS ⁽³⁾	2CTB803853R2300	512970		0.40	1
3	70 ⁽²⁾	30 ⁽²⁾	1.5	230	275	OVR T2 3L 70 275 s P	2CTB803853R4100	512994		0.35	1
3	70 ⁽²⁾	30 ⁽²⁾	1.5	230	275	OVR T2 3L 70 275s P TS ⁽³⁾	2CTB803853R4400	513007		0.40	1

TNS (3 Ph+N)

4	15 ⁽²⁾	5 ⁽²⁾	1.0	230	275	OVR T2 4L 15 275 P	2CTB803853R6000	513038		0.45	1
4	40 ⁽²⁾	20 ⁽²⁾	1.4	230	275	OVR T2 4L 40 275 P	2CTB 803853R5600	513274		0.45	1
4	40 ⁽²⁾	20 ⁽²⁾	1.4	230	275	OVR T2 4L 40 275sP	2CTB803853R5400	513021		0.45	1
4	40 ⁽²⁾	20 ⁽²⁾	1.4	230	275	OVR T2 4L 40 275 P TS	2CTB803853R5200	514417		0.50	1
4	40 ⁽²⁾	20 ⁽²⁾	1.4	230	275	OVR T2 4L 40 275s P TS ⁽³⁾	2CTB803853R5000	513014		0.50	1
4	70 ⁽²⁾	30 ⁽²⁾	1.5	230	275	OVR T2 4L 70 275 s P	2CTB803919R0200	513045		0.45	1
4	70 ⁽²⁾	30 ⁽²⁾	1.5	230	275	OVR T2 4L 70 275s P TS ⁽³⁾	2CTB803919R0400	513052		0.50	1

TT (3 Ph+N)

3+N	15/70 ⁽¹⁾	5/30 ⁽¹⁾	1.0/1.4 ⁽¹⁾	230	275/255 ⁽¹⁾	OVR T2 3N 15 275 P	2CTB803953R1200	513151		0.45	1
3+N	40/70 ⁽¹⁾	20/30 ⁽¹⁾	1.4/1.4 ⁽¹⁾	230	275/255 ⁽¹⁾	OVR T2 3N 40 275 P	2CTB803953R1100	513267		0.45	1
3+N	40/70 ⁽¹⁾	20/30 ⁽¹⁾	1.4/1.4 ⁽¹⁾	230	275/255 ⁽¹⁾	OVR T2 3N 40 275sP	2CTB803953R0800	513144		0.45	1
3+N	40/70 ⁽¹⁾	20/30 ⁽¹⁾	1.4/1.4 ⁽¹⁾	230	275/255 ⁽¹⁾	OVR T2 3N 40 275 P TS	2CTB803953R0500	514394		0.50	1
3+N	40/70 ⁽¹⁾	20/30 ⁽¹⁾	1.4/1.4 ⁽¹⁾	230	275/255 ⁽¹⁾	OVR T2 3N 40 275s P TS ⁽³⁾	2CTB803953R0200	513120		0.50	1
3+N	70/70 ⁽¹⁾	30/30 ⁽¹⁾	1.5/1.4 ⁽¹⁾	230	275/255 ⁽¹⁾	OVR T2 3N 70 275 s P	2CTB803953R0700	513137		0.45	1
3+N	70/70 ⁽¹⁾	30/30 ⁽¹⁾	1.5/1.4 ⁽¹⁾	230	275/255 ⁽¹⁾	OVR T2 3N 70 275s P TS ⁽³⁾	2CTB803953R0100	513113		0.50	1

(1) L-N / N-PE. (2) per pole. (3) TS: telesignal contact for remote control of the status of the Surge Protective Device. The safety reserve (s) ensures a preventive maintenance of the installation.

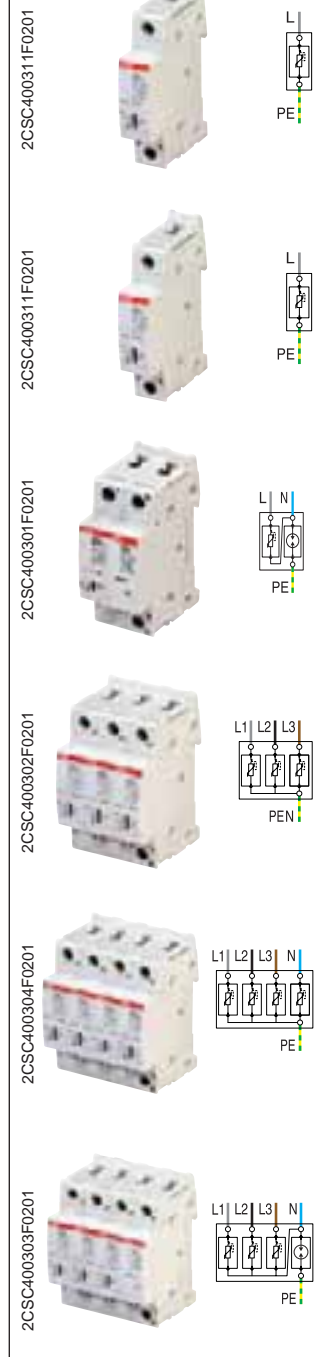

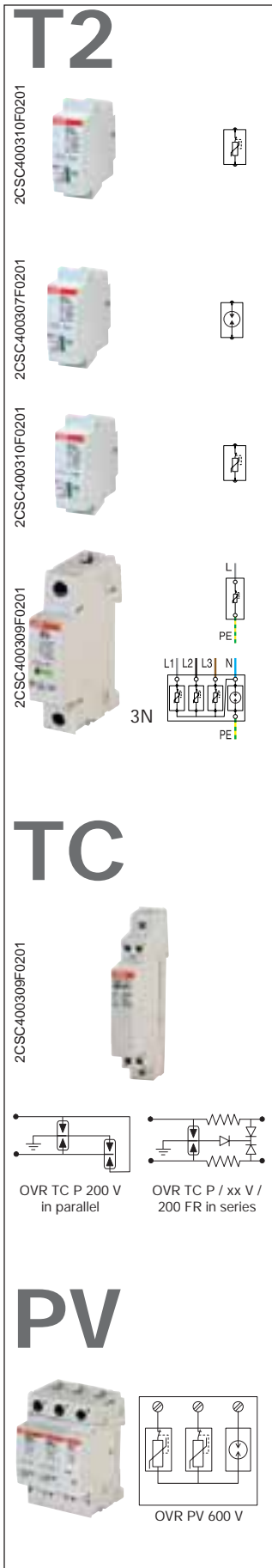

Nb. of poles	Maxi. discharge current I _{max} (8/20) kA	Nominal discharge current I _n (8/20) kA	Voltage protection level U _p kV	Nom. voltage U _n V	Max. cont. operating voltage U _c V	Order details	Bbn 3660308	Price 1 piece	Price group	Weight 1 piece	Pack unit
						Type code	Order code	EAN		kg	ppc.

Replacement cartridges for Surge Protective Devices Type 2

Phase cartridge, 275 V

-	15	5	1.0	230	275	OVR T2 15 275 C	2CTB803854R1200	513168		0.10	1
-	40	20	1.4	230	275	OVR T2 40 275 C	2CTB803854R1000	513182		0.10	1
-	40	20	1.4	230	275	OVR T2 40 275s C ⁽¹⁾	2CTB803854R0900	513199		0.10	1
-	70	30	1.5	230	275	OVR T2 70 275s C ⁽¹⁾	2CTB803854R0700	513229		0.10	1

Neutral cartridge for products OVR T2 1N (..) & OVR T2 3N (..), 275 V

-	70	30	1.4	-	440	OVR T2 70 N C	2CTB803854R0000	513243		0.05	1
---	----	----	-----	---	-----	---------------	-----------------	--------	--	------	---

Phase cartridge, 440 V

-	15	5	1.5	400	440	OVR T2 15 440 C	2CTB803854R0600	513175		0.10	1
-	40	20	1.9	400	440	OVR T2 40 440 C	2CTB803854R0400	513205		0.10	1
-	40	20	1.9	400	440	OVR T2 40 440s C ⁽¹⁾	2CTB803854R0300	513212		0.10	1
-	70	30	2.0	400	440	OVR T2 70 440s C ⁽¹⁾	2CTB803854R0100	513236		0.10	1

Type 2 (non pluggable)

1	15	5	1	230	275	OVR T2 15 275	2CTB804200R0100	514882		0.12	1
1	40	20	1.4	230	275	OVR T2 40 275	2CTB804201R0100	514103		0.12	1
1	40	20	1.4	230	275	OVR T2 3L 40 275	2CTB804601R0400	515964		0.35	1
1	40	20	1.4	230	275	OVR T2 4L 40 275	2CTB804211R0100	515612		0.45	1
1	40/40	20/20	1.4/1.4	230	275/255	OVR T2 3N 40 275	2CTB804301R0300	515940		0.45	1

(1) The safety reserve (s) ensures a preventive maintenance of the installation.

Surge Protective Devices, Low current

The transmission line pluggable surge arresters (OVR TC P) provide protection against transient overvoltages for equipment connected to telephone lines (digital or analog), computer links or current loops, for applications such as RS-485, or 4-20 mA.

1	10	5	0.015	6		OVR TC 6V P	2CTB804820R0000	515230		0.05	1
1	10	5	0.02	12		OVR TC 12V P	2CTB804820R0100	515247		0.05	1
1	10	5	0.035	24		OVR TC 24V P	2CTB804820R0200	515254		0.05	1
1	10	5	0.07	48		OVR TC 48V P	2CTB804820R0300	515261		0.05	1
1	10	5	0.7	200		OVR TC 200V P	2CTB804820R0400	515278		0.05	1
1	10	5	0.3	200		OVR TC 200FR P	2CTB804820R0500	515285		0.05	1
-	10	5	0.015	7		OVR TC 6V C	2CTB804821R0000	515292		0.02	1
-	10	5	0.02	14		OVR TC 12V C	2CTB804821R0100	515308		0.02	1
-	10	5	0.035	27		OVR TC 24V C	2CTB804821R0200	515315		0.02	1
-	10	5	0.07	53		OVR TC 48V C	2CTB804821R0300	515322		0.02	1
-	10	5	0.7	220		OVR TC 200V C	2CTB804821R0400	515339		0.02	1
-	10	5	0.3	220		OVR TC 200FR C	2CTB804821R0500	515346		0.02	1
1	-	-	-	-	-	Base OVR TC RJ11	2CTB804840R1000	515599		0.02	1
2	-	-	-	-	-	Base OVR TC RJ45	2CTB804840R1100	515605		0.04	1

Surge Protective Devices, Photovoltaic

The photovoltaic pluggable surge arresters OVR PV provide protection for equipment on photovoltaic system (connected & standalone), against transient overvoltages that occur on the electrical network.

2	30	10	0.3/0.6	75	100	OVR PV 30 75 P TS	2CTB803953R3100	514202		0.12	1
3	40	20	2.8/1.4	600	700	OVR PV 40 600 P	2CTC803953R5300	516511		0.27	1
3	40	20	2.8/1.4	600	700	OVR PV 40 600 P TS	2CTC803953R5400	516528		0.27	1
3	40	20	3.8	1000	1120	OVR PV 40 1000 P	2CTC803953R6400	516534		0.27	1
3	40	20	3.8	1000	1120	OVR PV 40 1000 P TS	2CTC803953R6500	516541		0.27	1



Other modular devices Protection devices

Index

Selection tables

RD2 residual current monitors.....	6/2
Toroidal transformers.....	6/3
E 930 fuse holders.....	6/4
M2160-M2060 fuse switches.....	6/6

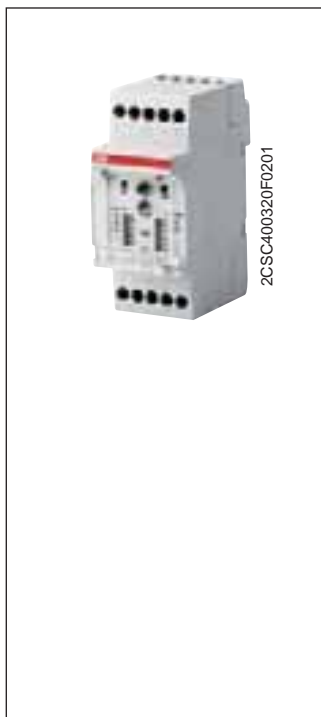

Residual current monitors (RCMs) with external transformer can detect leakage currents. Through minidip you can set sensitivity and intervention time. According to the same diameter, transformers are made in a single version for all relay sensitivity values.

RD2 residual current monitors

Operating voltage V	Order details Type code	Order code	Bbn 8012542 EAN	Price 1 piece	Price group	Weight 1 piece kg	Pack unit pc.
230...400 AC	RD2	2CSM142120R1201	058007			0.125	1
48...150 AC/DC	RD2-48	2CSM242120R1201	537809			0.125	1

6

Technical features

Operating voltage	[V]	230÷400 a.c. (RD2) and 48÷150 a.c./d.c. (RD2-48)
Frequency	[Hz]	50÷60
Sensitivity settings $I_{\Delta n}$	[A]	0.03; 0.1; 0.3; 0.5; 1; 2
Intervention time settings	[s]	Fast (instantaneous); 0.3; 0.5; 1; 2; 5
Contact capacity	[A]	10 at 250 V a.c. (ohmic)
Contact type		NC-C-NO
Operating temperature	[°C]	-5...+40
Modules	[n°]	2
Standards		IEC/EN 62020

Selection of calibration

$I_{\Delta n}$ (A)	0.03	0.1	0.3	0.5	1	2
0.03	<input type="checkbox"/>	<input type="checkbox"/>	<input type="checkbox"/>	<input type="checkbox"/>	<input type="checkbox"/>	<input type="checkbox"/>
0.1	<input type="checkbox"/>	<input type="checkbox"/>	<input type="checkbox"/>	<input type="checkbox"/>	<input type="checkbox"/>	<input type="checkbox"/>
0.3	<input type="checkbox"/>	<input type="checkbox"/>	<input type="checkbox"/>	<input type="checkbox"/>	<input type="checkbox"/>	<input type="checkbox"/>
0.5	<input type="checkbox"/>	<input type="checkbox"/>	<input type="checkbox"/>	<input type="checkbox"/>	<input type="checkbox"/>	<input type="checkbox"/>
1	<input type="checkbox"/>	<input type="checkbox"/>	<input type="checkbox"/>	<input type="checkbox"/>	<input type="checkbox"/>	<input type="checkbox"/>
2	<input type="checkbox"/>	<input type="checkbox"/>	<input type="checkbox"/>	<input type="checkbox"/>	<input type="checkbox"/>	<input type="checkbox"/>

Fast	0.3	0.5	1	2	5	Fast
<input type="checkbox"/>	<input type="checkbox"/>	<input type="checkbox"/>	<input type="checkbox"/>	<input type="checkbox"/>	<input type="checkbox"/>	<input type="checkbox"/>
<input type="checkbox"/>	<input type="checkbox"/>	<input type="checkbox"/>	<input type="checkbox"/>	<input type="checkbox"/>	<input type="checkbox"/>	<input type="checkbox"/>
<input type="checkbox"/>	<input type="checkbox"/>	<input type="checkbox"/>	<input type="checkbox"/>	<input type="checkbox"/>	<input type="checkbox"/>	<input type="checkbox"/>
<input type="checkbox"/>	<input type="checkbox"/>	<input type="checkbox"/>	<input type="checkbox"/>	<input type="checkbox"/>	<input type="checkbox"/>	<input type="checkbox"/>
<input type="checkbox"/>	<input type="checkbox"/>	<input type="checkbox"/>	<input type="checkbox"/>	<input type="checkbox"/>	<input type="checkbox"/>	<input type="checkbox"/>
<input type="checkbox"/>	<input type="checkbox"/>	<input type="checkbox"/>	<input type="checkbox"/>	<input type="checkbox"/>	<input type="checkbox"/>	<input type="checkbox"/>

Time (sec.)

Indications
Green LED: supply voltage present
Red LED: alarm status

More functions
The connection between the toroidal transformer and the residual current relay is continually checked by the relay; if the connection interrupts, the residual current relay enters the "alarm" status. The "test" pushbutton simulates - internally to the RD2 - the residual current conditions for the RD2 to operate. If pushed, the RD2 must enter the alarm status.
The "reset" pushbutton allows the residual current relay to return to the starting condition.

If the configuration is not appropriate, the device will automatically consider as valid the first configuration (according to the diagram) and enter the maximum safety.



Toroidal transformers

Dimension Ø	Order details		Bbn	Price	Price	Weight	Pack
mm	Type code	Order code	EAN	1 piece	group	1 piece	unit
						kg	pc.
29 (modular version)	TRM	2CSM029000R1211	020707			0.170	1
35*	TR1	2CSG035100R1211	020301			0.212	1
60*	TR2	2CSG060100R1211	020400			0.274	1
80*	TR3	2CSG080100R1211	020509			0.454	1
110*	TR4	2CSG110100R1211	020608			0.530	1
110 (open version)*	TR4/A	2CSG110200R1211	743408			0.600	1
160*	TR160	2CSG160100R1211	743507			1.350	1
160 (open version)*	TR160A	2CSG160200R1211	743606			1.600	1
210*	TR5	2CSG210100R1211	024804			1.534	1
210 (open version)*	TR5/A	2CSG210200R1211	065708			1.856	1

* Wiring terminals 1 and 2

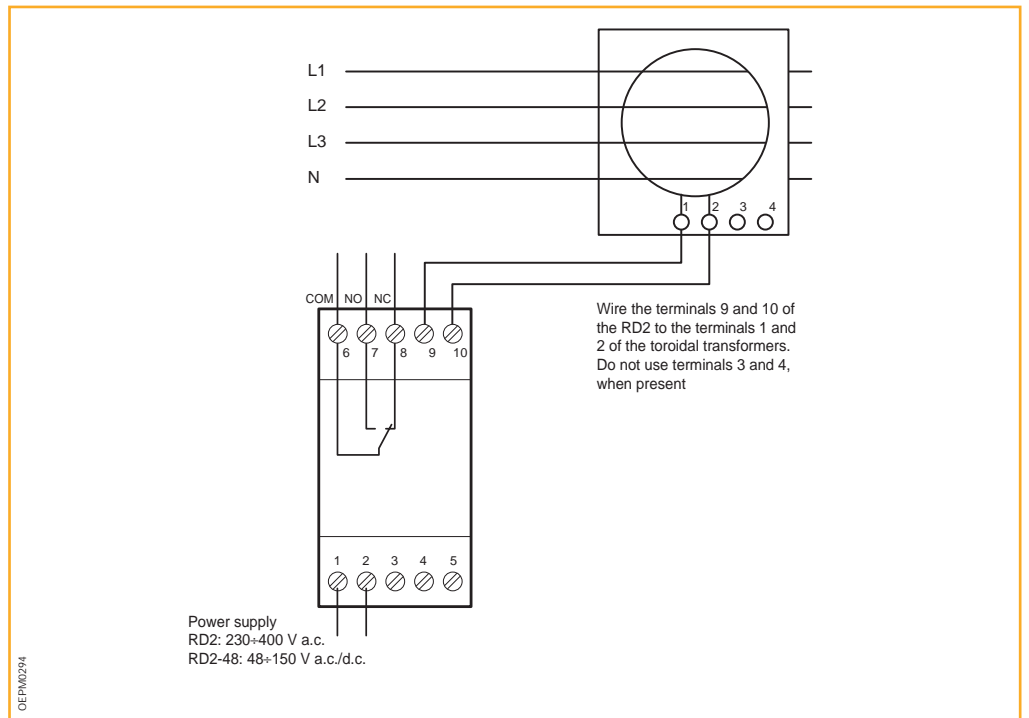

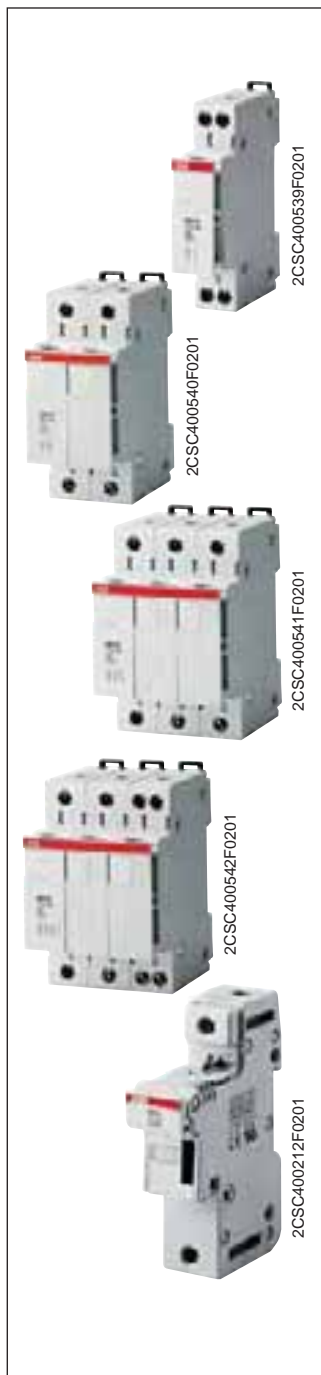

E 930 fuse holders are appropriate to protect against overloads and short circuits. They are designed for use with cylindrical fuses of 20, 32, 50 and 125 A.

They are provided with IP20 protection degree, and for each version (1P, 1P+N, ...) is also available on request sizes of 8.5x23 mm (up to 10 A), 10.3x25 mm (up to 16 A) and 10.3x31.5 mm (up to 25 A).

Fuse holders for 20 A fuses

Poles	Rated current I _n A	Modules	Order details Type code	Order code	Bbn 8012542 EAN	Price 1 piece	Price group	Weight 1 piece kg	Pack unit pc.
1	20	1	E 931/20	2CSM131210R1801	365006			0.100	6
1+N	20	1	E 931N/20	2CSM135210R1801	374404			0.150	6
2	20	2	E 932/20	2CSM132210R1801	365204			0.200	3
3	20	3	E 933/20	2CSM133210R1801	365303			0.300	2
3+N	20	3	E 933N/20	2CSM137210R1801	374503			0.350	2

Fuse holders for 32 A fuses

1	32	1	E 931/32	2CSM151510R1801	366003			0.100	6
1+N	32	1	E 931N/32	2CSM155510R1801	374602			0.150	6
2	32	2	E 932/32	2CSM152510R1801	366201			0.200	3
3	32	3	E 933/32	2CSM153510R1801	366300			0.300	2
3+N	32	3	E 933N/32	2CSM157510R1801	374701			0.350	2

Fuse holders for 50 A fuses

1	50	1.5	E 931/50	2CSM361610R1801	446804			0.200	6
1+N	50	3	E 931N/50	2CSM365610R1801	446903			0.400	3
2	50	3	E 932/50	2CSM362610R1801	447009			0.400	3
3	50	4.5	E 933/50	2CSM363610R1801	447108			0.600	1
3+N	50	6	E 933N/50	2CSM367610R1801	447207			0.800	1

Fuse holders for 125 A fuses

1	125	2	E 931/125	2CSM371710R1801	447504			0.200	6
1+N	125	4	E 931N/125	2CSM375710R1801	447603			0.400	3
2	125	4	E 932/125	2CSM372710R1801	447702			0.400	3
3	125	6	E 933/125	2CSM373710R1801	447801			0.600	1
3+N	125	8	E 933N/125	2CSM377710R1801	447900			0.800	1

Technical features

		20 A fuses	32 A fuses	50 A fuses	125 A fuses
Rated voltage U _n	[V]	a.c./d.c. 400	a.c./d.c. 400	a.c./d.c. 690	a.c./d.c. 690
Rated current I _n	[A]	20	32	50	125
Rated frequency	[Hz]	50/60	50/60	50/60	50/60
Fuse dimension	[mm]	8.5x31.5	10.3x38	14x51	22x58
Utilization category		-	-	AC20	AC20
Power consumption per pole		see technical details			
Standards		EN 60269-3; IEC 269-3		EN 60269-2; EN 60947-3 IEC 269-2; IEC 947-3	
Approvals		IMQ, LCIE	IMQ, LCIE	UL, CSA	UL, CSA

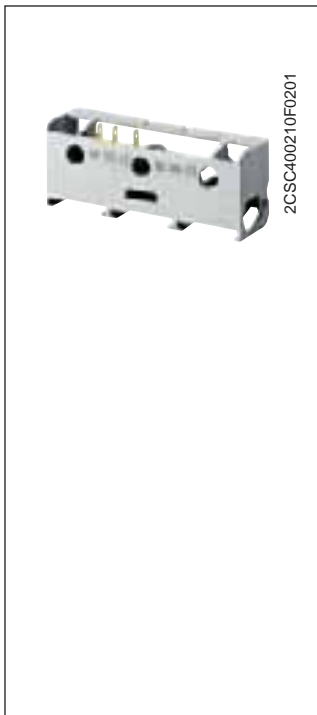

Accessories

Microswitch for remote signalling on fuse holders for fuses with built-in striker

Poles	Rated current In	Order details	Bbn 8012542	Price 1 piece	Price group	Weight 1 piece	Pack unit
A	Type code	Order code	EAN			kg	pc.
1	50	E 930/MCR1P50	2CSM060019R1801	451006		0.030	1
3	50	E 930/MCR3P50	2CSM060029R1801	451105		0.030	1
1	125	E 930/MCR1P125	2CSM070019R1801	451204		0.030	1
3	125	E 930/MCR3P125	2CSM070029R1801	451303		0.030	1

Kit for coupling max. 10 one pole fuses

Rated current In	Order details	Bbn 8012542	Price 1 piece	Price group	Weight 1 piece	Pack unit
A	Type code	Order code	EAN		kg	pc.
50	E 930/ACP50	2CSM060039R1801	451402		0.050	1
125	E 930/ACP125	2CSM070039R1801	451501		0.050	1

Transparent cover for signalling 20 A and 32 A fuse trip

Description	Order details	Bbn 8012542	Price 1 piece	Price group	Weight 1 piece	Pack unit
	Type code	Order code	EAN		kg	pc.
only cover	E 930/KIT	2CSM050018R1801	367000		0.020	5
cover+torpedo lamp (Un=230V)	E 930/KIT+Lamp	2CSM050028R1801	539902		0.050	5

6

Technical features

Minimum operating voltage and current	10 V a.c./d.c. - 100 mA
Nominal current and interrupting rating(1) at 250V	6 A AC12
	3 A AC13
	0,3 A AC14
	0,1 A DC12/13/14
Nominal current and interrupting rating(1) at 2 and 24 V	6 A DC12/DC13
	5 A AC13
	2 A AC14/DC13
	0,6 A DC14

(1) According to IEC947-5 Standard

Functions of the microswitch

- Signalisation of blown fuse (only with fuses with striker)
- Signalisation of fuse presence when the fuse holder is closed without any cartridge
- Signalisation of the position of the receptable
- Prebreaking (it's possible to interrupt the load supply by means of a prebreaking of the microswitch on the contactor)

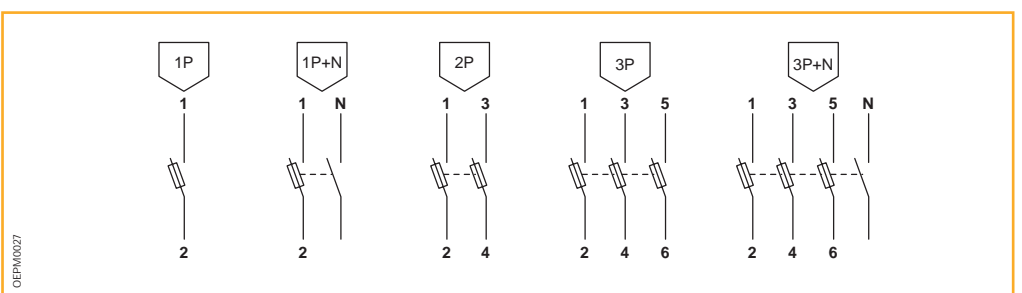
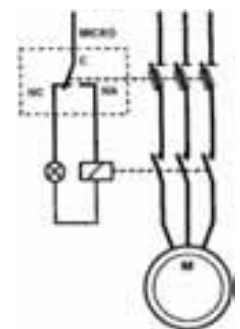



Fuse switches are used in tertiary and small industrial plants to open/close under load circuits, allowing protection against short circuits and overloads. The contact tongues are of silver-plated copper (fuse is not provided).

M2160: switches + fuses (8.5 x 31.5)

Poles	Modules	Order details		Bbn 8012542 EAN	Price 1 piece	Price group	Weight 1 piece kg	Pack unit pc.
		Type code	Order code					
1	1	M 2161	2CSM131210R1811	026808			0.100	12
1+N	2	M 2161 Na	2CSM135210R1811	026907			0.200	6
2	2	M 2162	2CSM132210R1811	027003			0.200	6
3	3	M 2163	2CSM133210R1811	027201			0.300	4
3+N	4	M 2163 Na	2CSM137210R1811	027102			0.400	3

M2060: switches + fuses (10.3 x 38)

Poles	Modules	Order details		Bbn 8012542 EAN	Price 1 piece	Price group	Weight 1 piece kg	Pack unit pc.
		Type code	Order code					
1	1	M 2061	2CSM131510R1811	027300			0.100	12
1+N	2	M 2061 Na	2CSM135510R1811	027409			0.200	6
2	2	M 2062	2CSM132510R1811	027508			0.200	6
3	3	M 2063	2CSM133510R1811	027607			0.300	4
3+N	4	M 2063 Na	2CSM137510R1811	027706			0.400	3

Technical features

Rated voltage U_n	[V]	a.c. 400
Rated current I_n	[A]	20
Rated frequency	[Hz]	50/60
Fuse dimension	[mm]	8.5x31.5; 10.3x38
Utilization category		AC-22
Power consumption		see technical details
Modules	[n°]	1, 2, 3, 4
Standards		EN 60947-3; IEC/EN 60669-1 IEC 947-3

The fuse can be inserted only with open switch.

Index

Selection tables

E 259 installation relays.....	7/2
E 200 switches	7/4
E 463/3, E 480/3 switches	7/7
E 250 latching relays	7/8
E 260 latching relays	7/14
E 220 switches	7/17
E 220 pushbuttons and indicator lamps	7/20
ESB series contactors	7/23
EN series contactors	7/25
E 234 CT-D electronic timers.....	7/26
E 232 staircase lighting time delay switches	7/34
STD dimmers.....	7/37
AT electro-mechanical time switches.....	7/41
DT digital time switches.....	7/45
CL logic relays.....	7/49



E 259 installation relays

For applications in public/tertiary sectors (i.e. control of lamps), they are equipped with manual command (temporary). They can also be coupled with additional and signal contacts. For using several E 259 installation relays side by side or at ambient temperature over 30 °C, it is necessary to use some spacer elements for heat dissipation which must be installed on the side of the relays (E 259-DIS, code 2CSM000800R0401, half module width).

Contacts/voltage	Order details	Bbn	Price	Price	Weight	Pack
	Type code	Order code	1 piece	group	1 piece	unit
					kg	pc.

Coil voltage Uc=8 V AC

1 NO	E 259 R10-8	2CSM211000R0401	533009		0.100	12
1 NO+1NC	E 259 R11-8	2CSM214000R0401	533405		0.100	12
2 NO	E 259 R20-8	2CSM212000R0401	533801		0.100	12

Coil voltage Uc=12 V AC or 6 V DC

1 NO	E 259 R10-12	2CSM311000R0401	532705		0.100	12
1 NO+1 NC	E 259 R11-12	2CSM314000R0401	533108		0.100	12
2 NO	E 259 R20-12	2CSM312000R0401	533504		0.100	12
1 CO	E 259 R001-12	2CSM315000R0401	536109		0.100	12
2 CO	E 259 R002-12	2CSM316000R0401	536406		0.100	12

Coil voltage Uc=24 V AC or 12 V DC

1 NO	E 259 R10-24	2CSM411000R0401	532903		0.100	12
1 NO+1 NC	E 259 R11-24	2CSM414000R0401	533207		0.100	12
2 NO	E 259 R20-24	2CSM412000R0401	533603		0.100	12
1 CO	E 259 R001-24	2CSM415000R0401	536307		0.100	12
2 CO	E 259 R002-24	2CSM416000R0401	536604		0.100	12

Modules with control coil

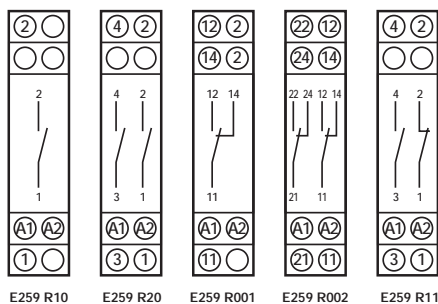

Auxiliary contacts

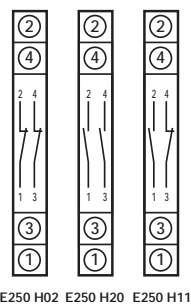

Additional contact modules

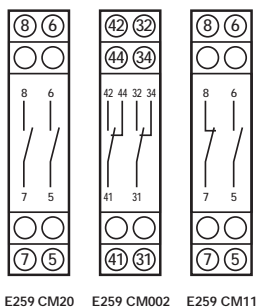



Coil voltage $U_c=230$ V AC or 115 V DC

1 NO	E 259 R10-230	2CSM111000R0401	532804	0.100	12
1 NO+1 NC	E 259 R11-230	2CSM114000R0401	533207	0.100	12
2 NO	E 259 R20-230	2CSM112000R0401	533603	0.100	12
1 CO	E 259 R001-230	2CSM115000R0401	536208	0.100	12
2 CO	E 259 R002-230	2CSM116000R0401	536505	0.100	12

Further coil voltages

1 NO+1NC/48 V AC or 24 V DC	E 259 R11-48	2CSM514000R0401	534204	0.100	12
2 NO/48 V AC or 24 V DC	E 259 R20-48	2CSM512000R0401	656708	0.100	12
1 NO+1NC/115 V AC or 48 V DC	E 259 R11-115	2CSM614000R0401	534006	0.100	12

Additional components

Description	Order details	Order code	Bbn	Price	Price	Weight	Pack
	Type code		8012542	1 piece	group	1 piece	unit
			EAN			kg	pc.
contact module 2 NO multi voltage	E 259 CM20	2CSM012100R0401	536000			0.100	12
contact module 1 NO+1NC multi voltage	E 259 CM11	2CSM014100R0401	535904			0.100	12
contact module 2 CO multi voltage	E 259 CM002	2CSM016100R0401	535805			0.100	12
auxiliary switches 1 NC+1 NO	E 250 H11	2CSM004400R0201	534709			0.100	12
auxiliary switches 2 NO	E 250 H20	2CSM002400R0201	536901			0.100	12
auxiliary switches 2 NC	E 250 H02	2CSM008400R0201	536802			0.100	12

Technical features

		E259 R10, E259 R20, E259 CM20, E 259 CMM, E259 R11	E259 R001, E 259 CM002, E259 R002
Rated voltage U_N	[V]	400/250	400/250
Rated current (according to EN 60947-4-1)	[A]	16	16
Rated frequency	[Hz]	50	50-60
Number of poles		1...4	1...4
Control circuit voltage		8, 12, 24, 48, 115, 230 V a.c.	12, 24, 230 V a.c.
Power supply voltage		6, 12, 24, 48, 60, 115, 220 V d.c.	12, 24 V d.c.
D.c./a.c. ratio		0.5:1	0.5:1
Operation limits (in % of U_N)	[%]	85-110	85-110
Power consumption*			
Alternated current			
holding	[VA]	3.8	4.0
pick-up	[VA]	6.0	4.0
Direct current	[W]	3.3	4.2
Service life (number of operations)			
Electrical (in AC-1 at full load)		3×10^5	4×10^5
Mechanical		2×10^7	2×10^7
Max. lamp power (10^3 operations/h)			
Incandescent and halogen (lamps from 40 to 200W)	[W]	1800	1800
Fluorescent, with capacitors ($\cos \phi = 0.9$)			
In series	[VA]	1800	1800
In parallel	[VA]	500	500
Fluorescent, without capacitors ($\cos \phi = 0.5$)	[VA]	900	900
Width (number of DIN modules)			
Motor unit	[n°]	1	1
With contact module	[n°]	2	2

* Low consumption relays on request E 259 LC

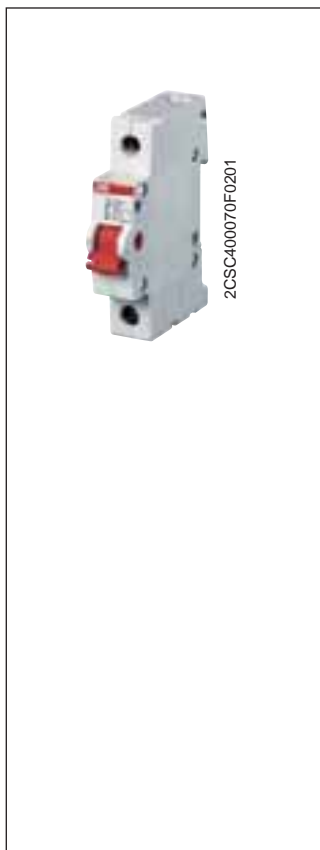

E 200 switches

Isolator for panel installation onto DIN rail acc. to DIN EN 60715

Mounting depth: 70mm
 Mounting width: per pole = 17.5mm = 1 module
 Colour: grey, RAL 7035
 Colour of switch lever: red RAL 3000 (r); grey RAL 7000 (g)

Special features

- Fast removal without dismantling of the busbar
- Captive screws with recessed/slotted head, Pozidriv size 2
- Add-on of up to 3 auxiliary contact S2C-H6R possible
- Integrated lay-on edge for labeling system ILS
- Locking device as accessories for unauthorized ON/OFF
- Approval: VDE, CCC

Poles	Rated voltage	Power loss	Order details	Bbn	Price	Price group	Weight	Pack unit
	V AC	W	Type code	Order code	EAN		kg	pc.

Rated current 16 A

1NO	230V	0.15	E201/16g	2CDE281001R1016	645614		0.095	10
1NO	230V	0.15	E201/16r	2CDE281001R0016	645621		0.095	10
2NO	400V	0.30	E202/16g	2CDE282001R1016	645799		0.190	5
2NO	400V	0.30	E202/16r	2CDE282001R0016	645805		0.190	5
3NO	400V	0.45	E203/16g	2CDE283001R1016	645973		0.290	3
3NO	400V	0.45	E203/16r	2CDE283001R0016	645980		0.290	3
4NO	400V	0.60	E204/16g	2CDE284001R1016	646154		0.390	2
4NO	400V	0.60	E204/16r	2CDE284001R0016	646161		0.390	2

Technical data

Switching capacity	1.25 x I _n ; 1.1 x U _n ; cos φ = 0.3 acc. to DIN VDE 0632 AC22-A/AC23-A acc. to VDE 0660 part 107, DIN EN 60947-3 resp. IEC 947-3 DC21-B for applications up to 60 V DC
Positive opening	acc. to DIN VDE 0113
Short-circuit withstand capacity	25 kA _{eff} in series with NH 00 100 A gL-gG; 6 kA _{eff} in series with NH 00 125 A gL-gG and S 2.. ≤63 A
Rated voltage	230/400 V AC; 50/60 Hz
Surge withstand capability U_{imp}	4 kV acc. to EN 60947-1
Ambient temperature	-25 °C to +55 °C
Storage temperature	-40 °C to +70 °C
Climatic resistance	constant climate 23/83, 40/93, 55/20 [°C/RH] alternating climate 25/95 - 40/93 [°C/RH]
Mounting position	optional
Degree of protection	IP10, IP40 in panelboard
Mechanical endurance	20000 switching cycles
Electrical endurance	1000 switching cycles
Min. voltage	12 V AC/DC at 0.1 VA
Min. contact loading	24 V/4 mA
Wire range	2.5 to 50 mm ²
Torque	5 Nm

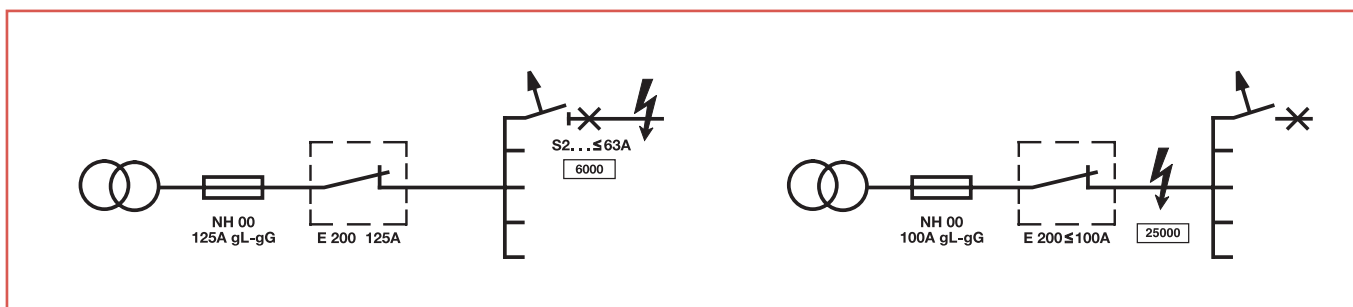



2CSC400065F0201

Rated current 25 A

1NO	230V	0.30	E201/25g	2CDE281001R1025	645638	0.095	10
1NO	230V	0.30	E201/25r	2CDE281001R0025	645645	0.095	10
2NO	400V	0.60	E202/25g	2CDE282001R1025	645812	0.190	5
2NO	400V	0.60	E202/25r	2CDE282001R0025	645829	0.190	5
3NO	400V	0.90	E203/25g	2CDE283001R1025	645997	0.290	3
3NO	400V	0.90	E203/25r	2CDE283001R0025	646000	0.290	3
4NO	400V	1.20	E204/25g	2CDE284001R1025	646178	0.390	2
4NO	400V	1.20	E204/25r	2CDE284001R0025	646185	0.390	2

Rated current 32 A

1NO	230V	0.50	E201/32g	2CDE281001R1032	645652	0.095	10
1NO	230V	0.50	E201/32r	2CDE281001R0032	645669	0.095	10
2NO	400V	0.95	E202/32g	2CDE282001R1032	645836	0.190	5
2NO	400V	0.95	E202/32r	2CDE282001R0032	645843	0.190	5
3NO	400V	1.40	E203/32g	2CDE283001R1032	646017	0.290	3
3NO	400V	1.40	E203/32r	2CDE283001R0032	646024	0.290	3
4NO	400V	1.90	E204/32g	2CDE284001R1032	646192	0.390	2
4NO	400V	1.90	E204/32r	2CDE284001R0032	646208	0.390	2

Rated current 40 A

1NO	230V	0.70	E201/40g	2CDE281001R1040	645676	0.095	10
1NO	230V	0.70	E201/40r	2CDE281001R0040	645683	0.095	10
2NO	400V	1.40	E202/40g	2CDE282001R1040	645850	0.190	5
2NO	400V	1.40	E202/40r	2CDE282001R0040	645867	0.190	5
3NO	400V	2.10	E203/40g	2CDE283001R1040	646031	0.290	3
3NO	400V	2.10	E203/40r	2CDE283001R0040	646048	0.290	3
4NO	400V	2.80	E204/40g	2CDE284001R1040	646215	0.390	2
4NO	400V	2.80	E204/40r	2CDE284001R0040	646222	0.390	2

Rated current 45 A

1NO	230V	0.90	E201/45g	2CDE281001R1045	645690	0.095	10
1NO	230V	0.90	E201/45r	2CDE281001R0045	645706	0.095	10
2NO	400V	1.80	E202/45g	2CDE282001R1045	645874	0.190	5
2NO	400V	1.80	E202/45r	2CDE282001R0045	645881	0.190	5
3NO	400V	2.65	E203/45g	2CDE283001R1045	646055	0.290	3
3NO	400V	2.65	E203/45r	2CDE283001R0045	646062	0.290	3
4NO	400V	3.50	E204/45g	2CDE284001R1045	646239	0.390	2
4NO	400V	3.50	E204/45r	2CDE284001R0045	646246	0.390	2

Rated current 63 A

1NO	230V	1.65	E201/63g	2CDE281001R1063	645713	0.095	10
1NO	230V	1.65	E201/63r	2CDE281001R0063	645720	0.095	10
2NO	400V	3.30	E202/63g	2CDE282001R1063	645898	0.190	5
2NO	400V	3.30	E202/63r	2CDE282001R0063	645904	0.190	5
3NO	400V	4.90	E203/63g	2CDE283001R1063	646079	0.290	3
3NO	400V	4.90	E203/63r	2CDE283001R0063	646086	0.290	3
4NO	400V	6.55	E204/63g	2CDE284001R1063	646253	0.390	2
4NO	400V	6.55	E204/63r	2CDE284001R0063	646260	0.390	2

Rated current 80 A

1NO	230V	2.60	E201/80g	2CDE281001R1080	645737	0.095	10
1NO	230V	2.60	E201/80r	2CDE281001R0080	645744	0.095	10
2NO	400V	5.15	E202/80g	2CDE282001R1080	645911	0.190	5
2NO	400V	5.15	E202/80r	2CDE282001R0080	645928	0.190	5
3NO	400V	7.75	E203/80g	2CDE283001R1080	646093	0.290	3
3NO	400V	7.75	E203/80r	2CDE283001R0080	646109	0.290	3
4NO	400V	10.30	E204/80g	2CDE284001R1080	646277	0.390	2
4NO	400V	10.30	E204/80r	2CDE284001R0080	646284	0.390	2

Rated current 100 A

1NO	230V	3.95	E201/100g	2CDE281001R1100	645751	0.095	10
1NO	230V	3.95	E201/100r	2CDE281001R0100	645738	0.095	10
2NO	400V	7.90	E202/100g	2CDE282001R1100	645935	0.190	5
2NO	400V	7.90	E202/100r	2CDE282001R0100	645942	0.190	5
3NO	400V	11.85	E203/100g	2CDE283001R1100	646116	0.290	3
3NO	400V	11.85	E203/100r	2CDE283001R0100	646123	0.290	3
4NO	400V	15.80	E204/100g	2CDE284001R1100	646291	0.390	2
4NO	400V	15.80	E204/100r	2CDE284001R0100	646307	0.390	2

Rated current 125 A

1NO	230V	6.10	E201/125g	2CDE281001R1125	645775	0.095	10
1NO	230V	6.10	E201/125r	2CDE281001R0125	645782	0.095	10
2NO	400V	12.20	E202/125g	2CDE282001R1125	645959	0.190	5
2NO	400V	12.20	E202/125r	2CDE282001R0125	645966	0.190	5
3NO	400V	18.30	E203/125g	2CDE283001R1125	646130	0.33	3
3NO	400V	18.30	E203/125r	2CDE283001R0125	646147	0.33	3
4NO	400V	24.35	E204/125g	2CDE284001R1125	646314	0.44	2
4NO	400V	24.35	E204/125r	2CDE284001R0125	646321	0.44	2



E 463/3-KB, E 480/3-KB, E 463/3-SL switches

Rated current A	Power loss W	Order details Type code	Order code	Bbn 7612270 EAN	Price 1 piece	Price group	Weight 1 piece kg	Pack unit pc.
63	5.4	E 463/3-KB	2CCE160300R0131	932528			0.190	1
63	5.5	E 463/3-SL	2CCE160301R0131	932535			0.195	1
80	9.9	E 480/3-KB	2CCE180300R0141	932542			0.210	1

Padlock for E 463/3-SL with 2 keys

Order details Type code	Order code	Bbn 7612270 EAN	Price 1 piece	Price group	Weight 1 piece kg	Pack unit pc.
SA 2	GJF1101903R0002	587704			0.020	1

Technical features

Switching capacity	1.25 In; 1.1 Un; $\cos\phi = 0.6$ according to DIN VDE 0632
Rated voltage	250/400 V a.c.
Connection cross section	1 mm ² stranded wire/0.5 mm ² wire up to 25 mm ²
Pick-up torque	3 Nm max.
Positive opening	according to DIN VDE 0113
Ambient temperature	-25°C to +55°C
Storage temperature	-40°C to +70°C
Poles	3 NO
Short-circuit withstanding capacity	10 kA, 400 V a.c.

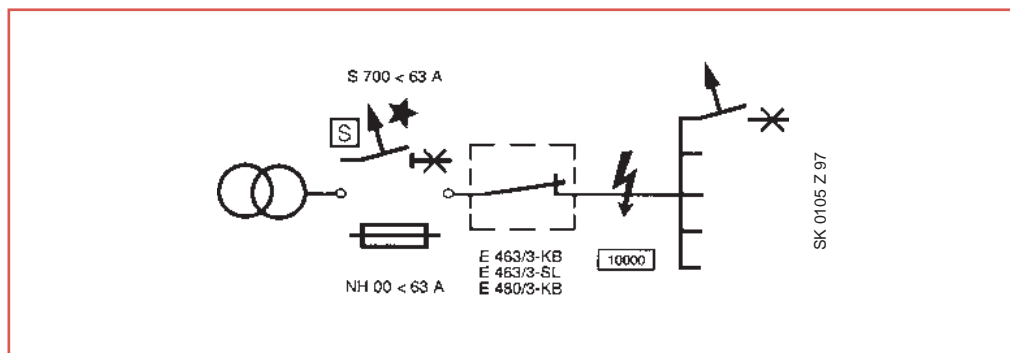



E 250 electro-mechanical latching relays

Electro-mechanical latching relays allow contact switching for each impulse sent to coil using normally open pushbuttons. Ideal for lamp remote controlling from different positions, they are available in various versions according to pick-up voltage and to contact positions. Basic modules are available in one-pole and bipolar versions and can be combined with bipolar contact modules in order to have three-pole and four-pole devices. E257C versions also allow centralized reset function (ON and OFF), that can be extended at a multi-level through the appropriate grouping module. They also allow manual operation on the product. They can also be equipped with signalling auxiliary contacts.

Contacts/voltage	Order details	Bbn	Price	Price	Weight	Pack
	Type code	Order code	1 piece	group	1 piece	unit
					kg	pc.

Coil voltage $U_c = 8 \text{ V AC } 16 \text{ A}$

1 NO	E 251-8	2CSM 211 000 R0201	53050 3		0.114	12
2 NO	E 252-8	2CSM 212 000 R0201	53100 5		0.116	12
1 NO + 1 NC	E 256-8	2CSM 214 000 R0201	53190 6		0.116	12
2 sequential	E 255-8	2CSM 219 000 R0201	53150 0		0.121	12

7

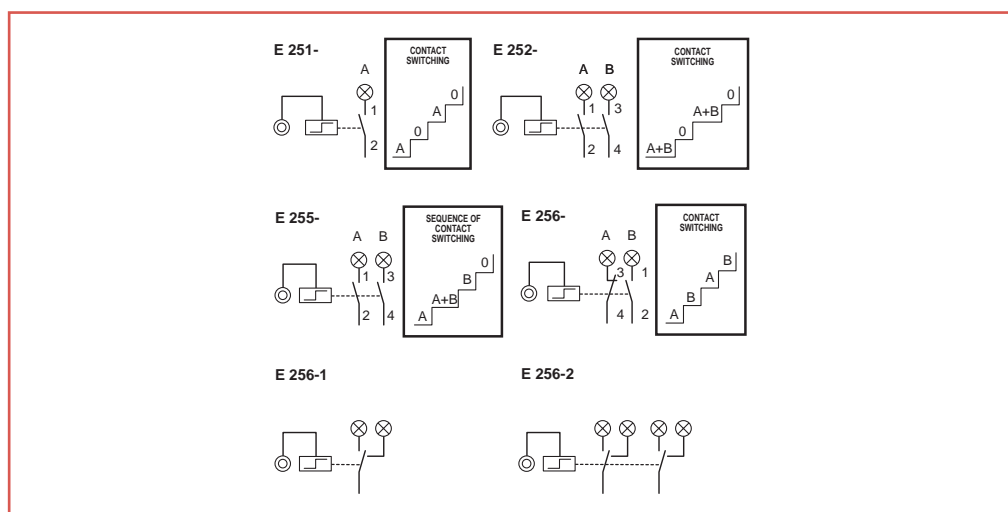

Examples of connection

Group centralized control: wiring diagram

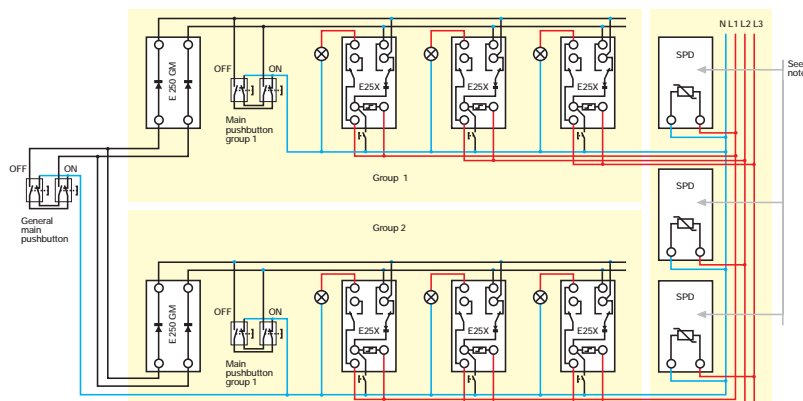

In the case of very long lines a surge protective device (SPD) is suggested. If the plant has been correctly implemented in terms of overvoltage protection we suggest a Class III SPD as a terminal protection.

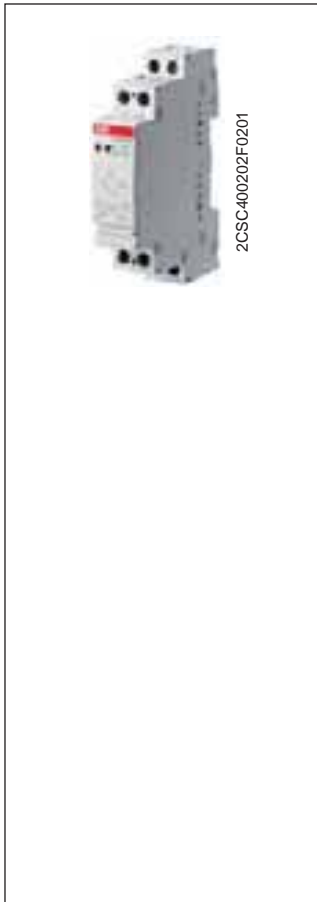

Contacts/voltage	Order details	Bbn	Price	Price group	Weight	Pack unit
	Type code	Order code	1 piece		1 piece	kg pc.
			8012542			
			EAN			

Coil voltage $U_c = 8\text{ V AC } 32\text{ A}$

1NA	E 251-32/8	2CSM231000R0201	91200 2		0.114	12
2NA	E 252-32/8	2CSM232000R0201	91260 6		0.116	12

Coil voltage $U_c = 12\text{ V AC or } 6\text{ V DC } 16\text{ A}$

1 NO	E 251-12	2CSM311000R0201	53020 6		0.114	12
2 NO	E 252-12	2CSM312000R0201	53070 1		0.116	12
1 NO + 1NC	E 256-12	2CSM314000R0201	53160 9		0.116	12
1 CO	E 256.1-12	2CSM315000R0201	53720 5		0.115	12
2 CO	E 256.2-12	2CSM316000R0201	53750 2		0.118	12
2 sequential	E 255-12	2CSM319000R0201	53120 3		0.121	12

Coil voltage $U_c = 12\text{ V AC or } 6\text{ V DC } 32\text{ A}$

1NA	E 251-32/12	2CSM331000R0201	91210 1		0.114	12
2NA	E 252-32/12	2CSM332000R0201	91270 5		0.116	12

Coil voltage $U_c = 24\text{ V AC or } 12\text{ V DC } 16\text{ A}$

1 NO	E 251-24	2CSM411000R0201	53040 4		0.114	12
2 NO	E 252-24	2CSM412000R0201	53090 9		0.116	12
1 NO + 1 NC	E 256-24	2CSM414000R0201	53180 7		0.116	12
1 CO	E 256.1-24	2CSM415000R0201	53740 3		0.115	12
2 CO	E 256.2-24	2CSM416000R0201	53770 0		0.118	12
2 sequential	E 255-24	2CSM419000R0201	53140 1		0.121	12

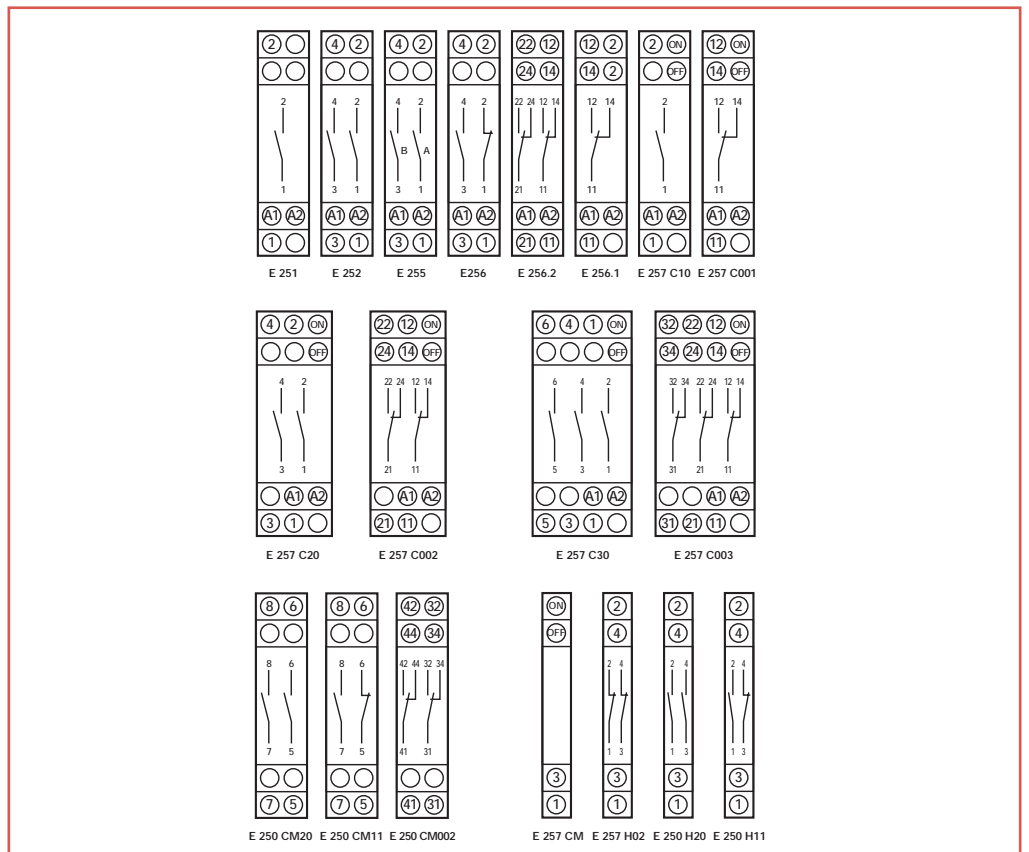



Coil voltage $U_c = 24 \text{ V AC or } 12 \text{ V DC } 32 \text{ A}$

1NA	E 251-32/24	2CSM431000R0201	91220 0	0.114	12
2NA	E 252-32/24	2CSM432000R0201	91280 4	0.116	12

Coil voltage $U_c = 48 \text{ V AC or } 24 \text{ V DC } 16 \text{ A}$

1 NO	E 251-48	2CSM511000R0201	53060 2	0.114	12
2 NO	E 252-48	2CSM512000R0201	53110 4	0.116	12
1 NO + 1NC	E 256-48	2CSM514000R0201	53200 2	0.116	12

Coil voltage $U_c = 48 \text{ V AC or } 24 \text{ V DC } 32 \text{ A}$

1NA	E 251-32/48	2CSM531000R0201	91230 9	0.114	12
2NA	E 252-32/48	2CSM532000R0201	91290 3	0.116	12

Coil voltage $U_c = 115 \text{ V AC or } 48 \text{ V DC } 16 \text{ A}$

1 NO	E 251-115	2CSM611000R0201	63090 6	0.114	12
2 NO	E 252-115	2CSM612000R0201	63100 2	0.114	12
1 NO + 1 NC	E 256-115	2CSM614000R0201	63020 3	0.114	12

Coil voltage $U_c = 115 \text{ V AC or } 48 \text{ V DC } 32 \text{ A}$

1NA	E 251-32/115	2CSM631000R0201	91240 8	0.114	12
2NA	E 252-32/115	2CSM632000R0201	91300 9	0.116	12

Technical features

	E 255	E 251/E 252/E 256	E 257 C
Rated load (according to EN 60669-2-2)			
250 V a.c. (1 and 2 poles)/400 V a.c. (3 and 4 poles) [A]	16	16/32	16/32
Direct current (30 V d.c.) [A]	16	16/32	16/32
Number of poles	2	1...4	1...3
Rated frequency [Hz]	50	50	50
Contacts			
Motor unit			
NO	1+1	1-2	1...3
CO	-	1-2	1...3
NO+NC	-	1+1	-
Contact modules			
NO	-	2	-
CO	-	2	-
NO+NC	-	1+1	-
Width (number of DIN modules)			
Motor unit [mod.]	1	1	1.5-2
With main contact unit [mod.]	-	2	-
Coil characteristics			
Supply voltage: d.c./a.c. ratio ①	0.5:1	0.5:1	0.5:1
Operation limits (in % of U_n) [%]	90-110	90-110	90-110
Alternated current Holding [VA]	11.0	11.0/11.5	11.0/14.5
Power consumption Pick-up [VA]	14.5	14.5/16.5	11.0/14.5
Direct current power consumption [W]	7.5	7.5/8	7.5/8
Max. time under supply ②			
Impulse endurance			
Minimum impulse endurance (at U_n) [s]	0.050	0.050	0.050
Minimum impulse endurance (90% U_n) [s]	0.100	0.100	0.100
Minimum interval between two impulses [s]	0.150	0.150	0.150
Max. impulse number per minute	250	250	250
Service life (number of operations) ③			
Electrical (in AC-1 at full load)	3×10^6	$4 \times 10^5 / 3 \times 10^5$	$4 \times 10^5 / 3 \times 10^5$
Mechanical	2×10^6	2×10^6	2×10^6

① Power supply voltage: all devices can operate at a.c. as well as d.c., according to the d.c./a.c. ratio: d.c. rated voltage = (a.c. rated voltage) x (d.c./a.c. ratio).

② The relays withstand the "blocked pushbutton" condition. When the permanent voltage operation is needed, it is necessary to use, on both sides, a spacer device (E 259-DIS code 2CSM000800R0401) and to ensure that the utilization factor allows the device to reach the ambient temperature.



Coil voltage $U_c = 230$ V AC or 115 V DC 16 A

1 NO	E 251-230	2CSM111000R0201	53030 5	0.114	12
2 NO	E 252-230	2CSM112000R0201	53080 0	0.116	12
1 NO + 1 NC	E 256-230	2CSM114000R0201	53170 8	0.116	12
1 CO	E 256.1-230	2CSM115000R0201	53730 4	0.115	12
2 CO	E 256.2-230	2CSM116000R0201	53760 1	0.118	12
2 sequential	E 255-230	2CSM119000R0201	53130 2	0.121	12

Coil voltage $U_c = 230$ V AC or 115 V DC 32 A

1NA	E 251-32/230	2CSM131000R0201	91250 7	0.114	12
2NA	E 252-32/230	2CSM132000R0201	91310 8	0.116	12

Coil voltage $U_c = 220$ V DC 16 A

2 NO	E 252-220DC	2CSM912000R0201	63000 5	0.116	12
------	-------------	-----------------	---------	-------	----

Coil voltage $U_c = 12$ V AC or 6 V DC, central ON/OFF, same electr. potential

1 NO	E 257 C10-12	2CSM311000R0211	53210 1	0.126	12
2 NO	E 257 C20-12	2CSM312000R0211	53240 8	0.174	8
3 NO	E 257 C30-12	2CSM313000R0211	53480 8	0.240	6
1 NO + central ON/OFF	E 257-32C10-12	2CSM331000R0211	91320 7	0.126	12
2 NO + central ON/OFF	E 257-32C20-12	2CSM332000R0211	91350 4	0.174	8
3 NO + central ON/OFF	E 257-32C30-12	2CSM333000R0211	91380 1	0.240	6
1 CO	E 257 C001-12	2CSM315000R0211	54020 5	0.126	12
2 CO	E 257 C002-12	2CSM316000R0211	54050 2	0.174	8
3 CO	E 257 C003-12	2CSM317000R0211	54080 9	0.240	6

7

	E 255	E 251/E 252/E 256	E 257 C
Load characteristics			
AC-1 maximum load in per phase [A]	20	20/32	20/32
DC maximum load (30 V d.c.) [A]	16	16	16
Minimum load per phase (under 5 V) [W]	2	2	2
Fuse against short circuit (gL) [A]	20	20/32	20/32
Rated frequency [Hz]	50	50	50
Maximum lamp power (10³ operations/h)			
Incandescent and halogen (lamps from 40 to 200 W) [W]	3000	3000	3000
Fluorescent, with capacitors (cosφ=0.9)			
In series [VA]	3000	3000/4000	3000/4000
In parallel [VA]	2500	2500/3200	2500/3200
Fluorescent, without capacitors (cosφ=0.5) [VA]	1800	1800/2200	1800/2200
Max. pushbutton number			
Not lighted pushbuttons	unlimited	unlimited	unlimited
Lighted pushbuttons			
3 wires	unlimited	unlimited	unlimited
2 wires	④	④	④
General characteristics			
Two-position handle	-	yes	yes
Contact position indicator	yes	yes	yes
Sealable terminals	yes	yes	yes
Cable section (ø min./max.) [mm ²]	1.5/10	1.5/10	1.5/10 (2P: 6)
Min./max. operating temperature [°C]	-20...+45	-20...+45	-20...+45

③ 1 cycle=2 operations per pole (close + open).

④ See E 250 CP compensation module table.

Contacts/voltage	Order details	Bbn	Price	Price	Weight	Pack
	Type code	Order code	8012542	1 piece	group	1 piece
			EAN		kg	pc.

Coil voltage $U_c = 24$ V AC or 12 V DC, central ON/OFF, same electr. potential

1 NO	E 257 C10-24	2CSM411000R0211	53230 9		0.126	12
2 NO	E 257 C20-24	2CSM412000R0211	53260 6		0.174	8
3 NO	E 257 C30-24	2CSM413000R0211	53500 3		0.240	6
1 NO + central ON/OFF	E 257-32C10-24	2CSM431000R0211	91330 6		0.126	12
2 NO + central ON/OFF	E 257-32C20-24	2CSM432000R0211	91360 3		0.174	8
3 NO + central ON/OFF	E 257-32C30-24	2CSM433000R0211	91390 0		0.240	6
1 CO	E 257 C001-24	2CSM415000R0211	54010 6		0.126	12
2 CO	E 257 C002-24	2CSM416000R0211	54040 3		0.174	8
3 CO	E 257 C003-24	2CSM417000R0211	54070 0		0.240	6

Coil voltage $U_c = 230$ V AC or 115 V DC, central ON/OFF, same electr. potential

1 NO	E 257 C10-230	2CSM111000R0211	53220 0		0.126	12
2 NO	E 257 C20-230	2CSM112000R0211	53250 7		0.174	8
3 NO	E 257 C30-230	2CSM113000R0211	53490 7		0.240	6
1 NO + central ON/OFF	E 257-32C10-230	2CSM131000R0211	91340 5		0.126	12
2 NO + central ON/OFF	E 257-32C20-230	2CSM132000R0211	91370 2		0.174	8
3 NO + central ON/OFF	E 257-32C30-230	2CSM133000R0211	91400 6		0.240	6
1 CO	E 257 C001-230	2CSM115000R0211	54000 7		0.126	12
2 CO	E 257 C002-230	2CSM116000R0211	54030 4		0.174	8
3 CO	E 257 C003-230	2CSM117000R0211	54060 1		0.240	6

Coil voltage $U_c = 230$ V AC or 115 V DC (local), 24 V AC or 24 V DC (central)

1 NO	E 258 C10-230/24	2CSM211000R0231	78910 9		0.226	6
2 NO	E 258 C20-230/24	2CSM212000R0231	78830 0		0.235	6
1 NO + 1 NC	E 258 C11-230/24	2CSM213000R0231	78870 6		0.232	6
1 NO + 1 NC + 1 CO	E 258 C111-230/24	2CSM215000R0231	78890 4		0.239	6
2 NO + 1 CO	E 258 C201-230/24	2CSM214000R0231	78850 8		0.241	6
2 CO	E 258 C002-230/24	2CSM216000R0231	78960 4		0.250	6
3 CO	E 258 C003-230/24	2CSM217000R0231	78990 1		0.256	6

Coil voltage $U_c = 230$ V AC or 115 V DC (local), 230 V AC or 230 V DC (central)

1 NO	E 258 C10-230/230	2CSM111000R0231	78920 8		0.233	6
2 NO	E 258 C20-230/230	2CSM112000R0231	78840 9		0.243	6
1 NO + 1 NC	E 258 C11-230/230	2CSM113000R0231	78880 5		0.240	6
1 NO + 1 NC + 1 CO	E 258 C111-230/230	2CSM115000R0231	78900 0		0.244	6
2 NO + 1 CO	E 258 C201-230/230	2CSM114000R0231	78860 7		0.247	6
2 CO	E 258 C002-230/230	2CSM116000R0231	78970 3		0.257	6
3 CO	E 258 C003-230/230	2CSM117000R0231	79000 6		0.262	6

Coil voltage $U_c = 24 \text{ V AC}$ or 12 V DC (local), 24 V AC or 24 V DC (central)

1 NO	E 258 C10-24/24	2CSM411000R0231	79010 5	0.225	6
2 NO	E 258 C20-24/24	2CSM412000R0231	78930 7	0.234	6
2 NO + 1 CO	E 258 C201-24/24	2CSM414000R0231	78940 6	0.241	6
2 CO	E 258 C002-24/24	2CSM416000R0231	78950 5	0.249	6
3 CO	E 258 C003-24/24	2CSM417000R0231	78980 2	0.256	6

Supplementary components

Description	Order details		Bbn	Price 1 piece	Price group	Weight 1 piece	Pack unit
	Type code	Order code	EAN				
contact module 2 NO multi voltage 16 A	E 250 CM20	2CSM012100 R0201	53460 0			0.058	10
contact module 1 NO + 1 NC multi voltage	E 250 CM11	2CSM014100R0201	53450 1			0.058	10
contact module 2CO multi voltage	E 250 CM002	2CSM016100R0201	53440 2			0.059	10
central contact module	E 257 CM	2CSM000200R0211	53510 2			0.062	16
auxiliary switches 1 NO + 1 NC	E 250 H11	2CSM004400R0201	53470 9			0.033	16
auxiliary switches 2 NO	E 250 H20	2CSM002400R0201	53690 1			0.033	16
auxiliary switches 2 NC	E 250 H02	2CSM008400R0201	53680 2			0.033	16
compensator	E 250 CP	2CSM000500R0201	53710 6			0.058	12
group module	E 250-GM	2CSM000600R0201	53700 7			0.058	12
contact module 2 NO multi voltage 32 A 250 V AC	E 250-32-CM 20	2CSM032100R0201	914105			0.058	10

E 260 electronic latching relays

The electronic version of latching relays guarantees maximum reliability, life, and noiseless operation. The E 260 C version also allows centralized reset function (ON/OFF).

Contacts	Power loss W ①	Order details Type code	Order code	Bbn 4016779 EAN	Price 1 piece	Price group	Weight 1 piece kg	Pack unit pc.
----------	-------------------	----------------------------	------------	-----------------------	------------------	----------------	-------------------------	---------------------

① Values in brackets indicate power loss when permanently excited, rated voltage and rated contact loading.

Latching relays with control electronics

Coil voltage $U_c = 24 \text{ V AC/DC}$

1 NO	2.4 (3.0)	E 261-24	2CDE441000R0301	57592 8			0.085	1
1 NO+1 NC	2.4 (3.5)	E 266-24	2CDE444000R0301	57595 9			0.096	1
2 NO	2.4 (3.5)	E 262-24	2CDE442000R0301	57593 5			0.096	1

Coil voltage $U_c = 230 \text{ V AC}$

1 NO	1.5 (2.0)	E 261-230	2CDE141000R0301	57596 6			0.085	1
1 NO+1 NC	1.7 (3.6)	E 266-230	2CDE144000R0301	57598 0			0.096	1
2 NO	1.7 (3.6)	E 262-230	2CDE142000R0301	57597 3			0.096	1



7

Connection examples

E 261-230

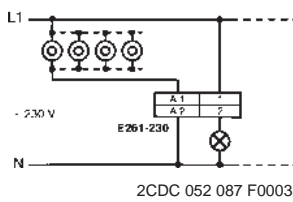

E 261 C-230

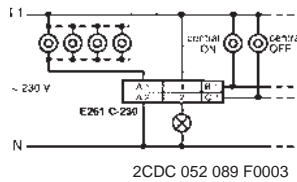

E 266 C-230

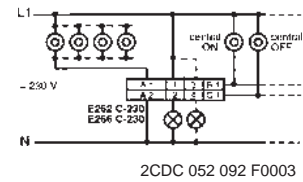

E 261-24

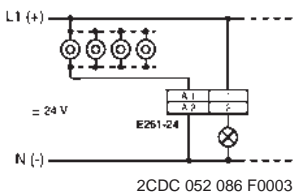

E 261 C-24

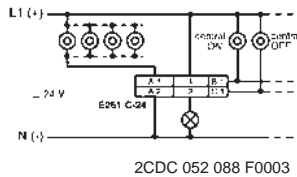

* E 260 C
Caution!
The same electr. potential must be applied to terminals A1, B1 and C1.



Latching relays with returning time

They switch off automatically after expiry of preset delay time (1 to 60 min.) if the manual OFF command has not been received. Glow lamp current 50 mA.

Coil voltage $U_c = 230 \text{ V AC}$

1 NO	1.5 (2.0)	E 261 SRV-230	2CDE111010R0301	48570 8	0.07	1
------	-----------	---------------	-----------------	---------	------	---

Technical features

	E 260/E 260 C	E 261 SRV-230
Rated load at 250 V AC	8 A/250 V AC	16 A/250 V AC
Incandescent lamp load	1000 W	1600 W
Fluorescent lamp load in twin-lamp circuit	1000 W	1000 W
Fluorescent lamp load shunt compensated	350 W ①	500 W
Fluorescent lamp load inductive or capacitive	500 W	1000 W
Electronic ballast	$I_{on} \text{ m } 70 \text{ A}/10 \text{ ms } ②$	$I_{on} \text{ m } 70 \text{ A}/10 \text{ ms a}$
Inductive load, $\cos \varphi = 0.6/230 \text{ V -}$	5 A	5 A
Contact rating at DC	100 W	100 W
Minimum contact rating	4 V AC/10 mA	4 V AC/10 mA
Contact gap/contact material	0.5 mm/Ag SnO ₂	0.5 mm/Ag SnO ₂
Service life mechanical switchover at 10 ³ /h	> 10 ⁷	> 10 ⁷
Service life at rated load $\cos \varphi = 1$ and 10 ³ /h	> 10 ⁵	> 10 ⁵
Service life with filament lamps 1000 W and 10 ³ /h	> 10 ⁵	> 10 ⁵
Service life at rated load $\cos \varphi = 0.6$ and 10 ³ /h	> 10 ⁴	> 10 ⁴
Max. switching rate	10 ³ /h	10 ³ /h
Bounce time	3 ms	
Connection capacity	2 x 1.5 mm ² with connector sleeve 2 x 2.5 mm ² without connector sleeve	
Tightening torque	0.5 ... 0.8 Nm	0.5 ... 0.8 Nm
ON duration at rated voltage	100 %	100 %
Coil voltage range	0.9 to 1.1 U_n	0.9. to 1.1 U_n
Minimum command time/interval between commands	50/1000 ms	50 ms
Ambient temperature	- 20 °C/- 4°F to 50 °C/122°F	- 20 °C/- 4°F to 50 °C/122°F
Control current when controlled locally	230 V AC 115 mA, after 10s 8 mA ± 20 % 24 V UC 140 mA, after 10s 80 mA ± 20 %	
Control current when controlled centrally	230 V AC 8 mA, after 10s 3 mA ± 20 % 24 V UC 17 mA ± 20 %	
Max. parallel capacity of individual control wire at 230 V -	0.7 µF (ca. 2000 m)	
Max. parallel capacity of central control wire at 230 V -	0.2 µF (ca. 700 m)	
Max. glow lamp current - parallel to 230 V control buttons	10 mA	10 mA
Max. induced voltage at 230 V control inputs	0.2 U_n	120 V

Latching relays for lamp installations on request.

① E 260 C can not be used with fluorescent lamp load shunt compensated.

② In the case of electronic control gear, take into account a 40-fold inrush current.

Latching relays with control electronics for central ON/OFF switch

The central commands have always priority and reliably switch on/off any given number of devices connected in parallel, irrespective of their previous switching position. Local control inputs are blocked when a central command is received. Same potential at central / local control input.

Contacts	Power loss	Order details	Bbn	Price	Price group	Weight	Pack unit
	W ①	Type code	Order code	4016779	1 piece	1 piece	kg
				EAN			pc.

① Values in brackets indicate power loss when permanently excited, rated voltage and rated contact loading.

Coil voltage $U_c = 24$ V AC/DC

1 NO	2.4 (3.0)	E 261 C-24	2CDE441000R0311	57599 7		0.085	1
1 NO+1 NC	2.4 (3.5)	E 266 C-24	2CDE444000R0311	57601 7		0.096	1
2 NO	2.4 (3.5)	E 262 C-24	2CDE442000R0311	57600 0		0.096	1

Coil voltage $U_c = 230$ V AC

1 NO	1.5 (2.0)	E 261 C-230	2CDE141000R0311	57602 4		0.085	1
1 NO+1 NC	1.7 (3.0)	E 266 C-230	2CDE144000R0311	57604 8		0.096	1
2 NO	1.7 (3.0)	E 262 C-230	2CDE142000R0311	57603 1		0.096	1

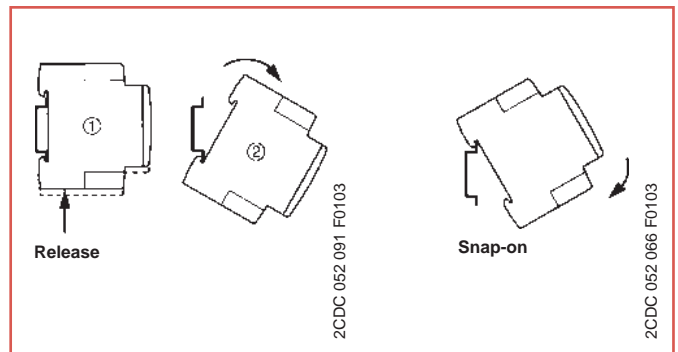
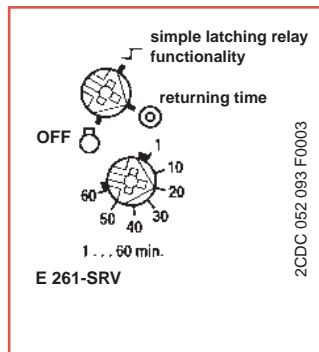

Terminal assignment

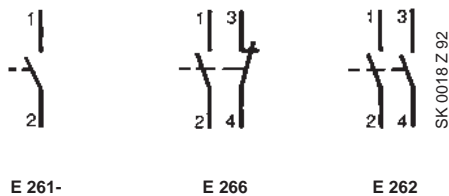
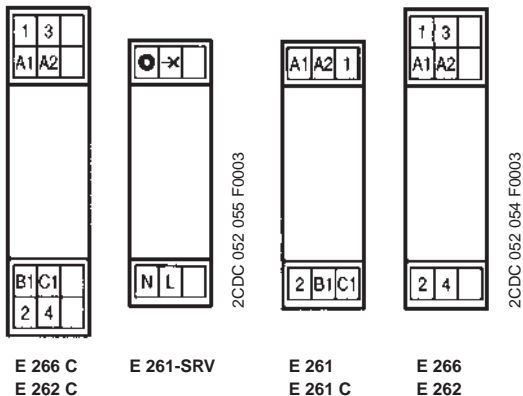



E 220 switches

Suitable for underload operation and equipped with sealable control lever in both positions. All devices are manufactured in a single module, through simple, quick and safe procedures. For correct operation, they need an upstream protection by devices against short-circuit and overload (fuses, MCBs).

Type	Rated voltage	Power loss	Order details	Bbn	Price	Price group	Weight	Pack unit
	V AC	W	Type code	7612270	1 piece		1 piece	
				Order code	EAN		kg	pc.

Control switches

Rated current = 16 A

2 NO+2 NC	250	1.92	E 221-22	2CCE 110 900 R0101	93256 6		0.070	10
3 NO+1 NC	400	1.92	E 221-31	2CCE 111 000 R0101	93257 3		0.070	10
1 NO+1 NC	250	0.96	E 221-11	2CCE 110 800 R0101	93255 9		0.070	10

Rated current = 25 A

1 NO+1 NC	250	2.26	E 222-11	2CCE 120 800 R0111	93262 7		0.070	10
-----------	-----	------	----------	--------------------	---------	--	-------	----

One-way switches

Rated current = 16 A

1 NO	250	0.48	E 221-10	2CCE 110 100 R0101	93234 4		0.055	10
2 NO	250	0.96	E 221-20	2CCE 110 200 R0101	93236 8		0.060	10
3 NO	400	1.44	E 221-30	2CCE 110 300 R0101	93238 2		0.065	10
4 NO	400	1.92	E 221-40	2CCE 110 400 R0101	93240 5		0.070	10

Rated current = 25 A

1 NO	250	1.13	E 222-10	2CCE 120 100 R0111	93241 2		0.055	10
2 NO	250	2.26	E 222-20	2CCE 120 200 R0111	93243 6		0.060	10
3 NO	400	3.39	E 222-30	2CCE 120 300 R0111	93245 0		0.065	10
4 NO	400	4.52	E 222-40	2CCE 120 400 R0111	93247 4		0.070	10

Technical features

Switching capacity	1.25 I _n ; 1.1 U _n ; cosφ = 0.6 according to DIN VDE 0632, AC 22 according to VDE 0660 Part 107, IEC 947-3
Short-circuit-withstand capacity	3 kA, 400 V, cosφ = 0.8
Sealable	in ON and OFF positions
Climatic resistance	constant climate 40/92 DIN 50 015 alternating climate SFW DIN 50 017
Ambient temperature	- 25 °C/- 13° F to + 55 °C/131° F
Storage temperature	- 40 °C to + 70 °C
Connection capacity	from 1 x 1 mm ² to 1 x 6 mm ² or 2 x 2.5 mm ² massive; from 1 x 0.75 mm ² to 2 x 1.5 mm ² flexible with connector sleeve or pin-end connector
Positive opening	according to DIN VDE 0113
Rated voltage	250/400 V AC
Minimum rated voltage	24 V DC/AC



Type	Rated voltage V AC	Power loss W	Order details Type code	Order code	Bbn 7612270 EAN	Price 1 piece	Price group	Weight 1 piece kg	Pack unit pc.
------	-----------------------	-----------------	----------------------------	------------	-----------------------	------------------	----------------	-------------------------	---------------------

Rated current = 32 A

1 NO	250	2.2	E 223-10	2CCE 130 100 R0121	93248 1			0.055	10
2 NO	250	4.4	E 223-20	2CCE 130 200 R0121	93249 8			0.060	10
3 NO	400	6.6	E 223-30	2CCE 130 300 R0121	93250 4			0.065	10
4 NO	400	8.8	E 223-40	2CCE 130 400 R0121	93251 1			0.070	10

One-way switches with built-in pilot lamp for 230 V~

Rated current = 16 A

1 NO	250	0.5	E 221-10 x	2CCE 110 103 R0101	93235 1			0.060	10
2 NO	250	1.0	E 221-20 x	2CCE 110 203 R0101	93237 5			0.065	10
3 NO	400	1.5	E 221-30 x	2CCE 110 303 R0101	93239 9			0.087	10

Rated current = 25 A

1 NO	250	1.15	E 222-10 x	2CCE 120 103 R0111	93242 9			0.060	10
2 NO	250	2.30	E 222-20 x	2CCE 120 203 R0111	93244 3			0.065	10
3 NO	400	3.45	E 222-30 x	2CCE 120 303 R0111	93246 7			0.087	10

Two-way switches

Rated current = 16 A

1 CO	250	0.48	E 221-6	2CCE 110 500 R0101	93260 3			0.060	10
2 CO	250	0.96	E 221-6/2	2CCE 110 600 R0101	93261 0			0.070	10

E 220 DC switching capacity

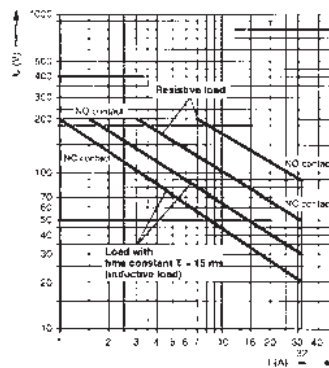

SK 0079 Z00

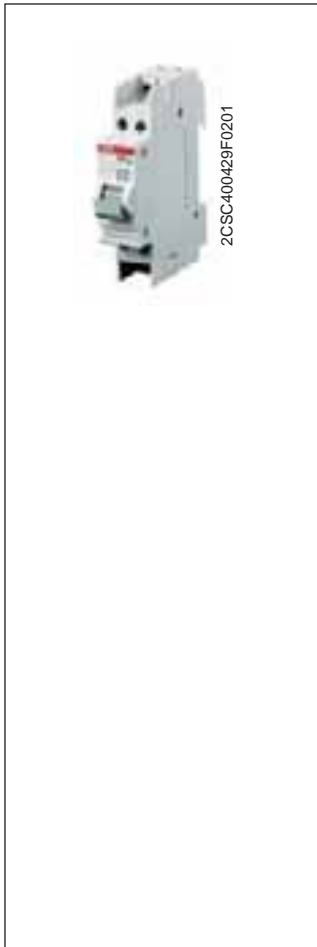

Rated current = 25 A

1 CO	250	1.13	E 222-6	2CCE 120 500 R0121	932658	0.060	10
------	-----	------	---------	--------------------	--------	-------	----

Two-way switch with two off positions (I-O-II, manual-OFF-automatic)

Rated current = 16 A

1-pole	250	0.48	E 221-4	2CCE 110 502 R0101	93258 0	0.060	10
2-pole	250	0.96	E 221-4/2	2CCE 110 602 R0101	93259 7	0.070	10

Rated current = 25 A

1-pole	250	1.13	E 222-4	2CCE 120 520 R0111	93263 4	0.060	10
--------	-----	------	---------	--------------------	---------	-------	----

Terminal assignment



SK 0170 Z 91

control switch



one-way switch

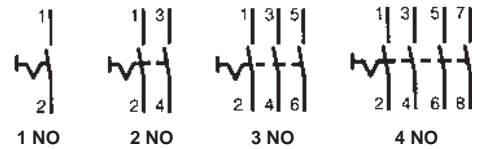

one-way switch with pilot lamp

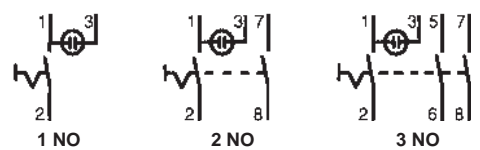

two-way switch

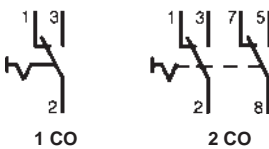

2CDC 052 165 F0004

group switch

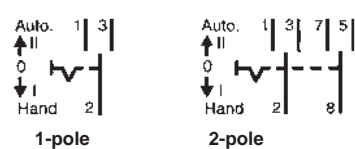

2CDC 052 166 F0004

2CDC 052 163 F0004
2CDC 052 164 F0004

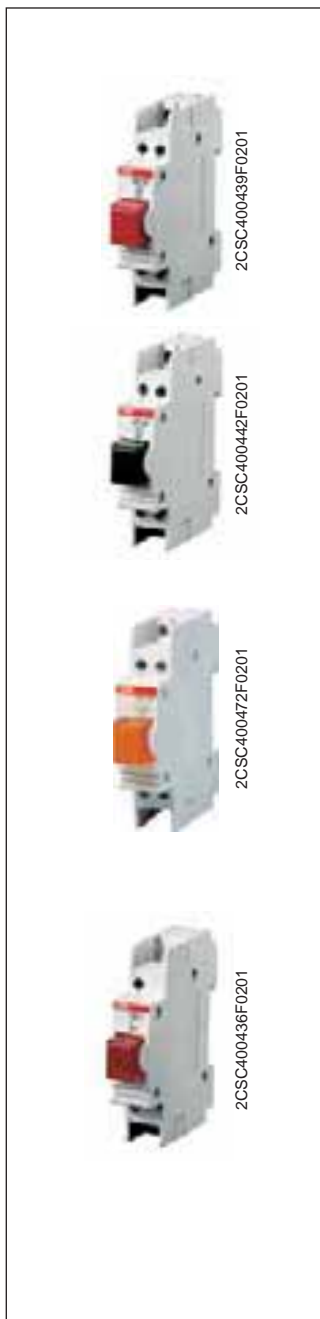

E 220 pushbuttons and indicator lamps

The pushbuttons are used for remote control in every kind of electric installation (public, tertiary, industrial).

The indicator lamps signal any event in every kind of electric installation (public, tertiary, industrial).

Not lighted pushbuttons with contacts 1NO+1NC

Hood's colour	Order details		Bbn 7612270	Price 1 piece	Price group	Weight 1 piece	Pack unit
	Type code	Order code	EAN			kg	pc.
grey	E225-11 B	2CCE110810R0001	932665			0.055	10
red	E225-11 C	2CCE110820R0001	932672			0.055	10
green	E225-11 D	2CCE110830R0001	932689			0.055	10
yellow	E225-11 E	2CCE110840R0001	932696			0.055	10
black	E225-11 F	2CCE110850R0001	932702			0.055	10
blue	E225-11 G	2CCE110860R0001	932719			0.055	10
no hood	E225-11 Z	2CCE110804R0001	932726			0.053	10

Lighted pushbuttons with contacts 1NO+1NC

Button's colour	Order details		Bbn 7612270	Price 1 piece	Price group	Weight 1 piece	Pack unit
	Type code	Order code	EAN			kg	pc.
transparent	E227-11 B	2CCE110870R0011	932740			0.055	10
red	E227-11 C	2CCE110820R0011	932757			0.055	10
green	E227-11 D	2CCE110830R0011	932764			0.055	10
yellow	E227-11 E	2CCE110840R0011	932771			0.055	10
blue	E227-11 G	2CCE110860R0011	932788			0.055	10
no button - no lamp	E227-11 Z	2CCE110804R0011	932795			0.045	10

Indicator lamps with 230 V a.c. bulb

Hood's colour	Order details		Bbn 7612270	Price 1 piece	Price group	Weight 1 piece	Pack unit
	Type code	Order code	EAN			kg	pc.
transparent	E229-B	2CCE100070R0021	932801			0.045	10
red	E229-C	2CCE100020R0021	932818			0.045	10
green	E229-D	2CCE100030R0021	932825			0.045	10
yellow	E229-E	2CCE100040R0021	932832			0.045	10
blue	E229-G	2CCE100060R0021	932849			0.045	10
no hood	E229-Z	2CCE100004R0021	932856			0.040	10

Technical features

Rated voltage Un	[V]	a.c. 250
Rated current In	[A]	16
Rated frequency	[Hz]	50/60
Power consumption	[W]	see technical details
Modules	[No]	1
Standards		IEC EN 60669-1
Approvals		CCC, UR, CSA, VDE, GOST, BBJ, KEMA

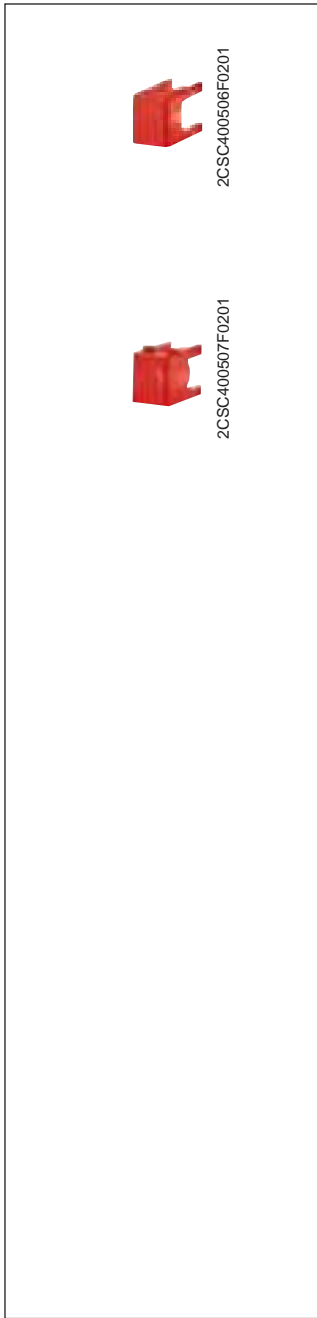

Hoods for not lighted pushbuttons E225

Hood's colour	Order details	Bbn	Price	Price	Weight	Pack
	Type code	Order code	1 piece	group	1 piece	unit
					kg	pc.
grey	E220-B 1	2CCE000015R0001	7612270	932948	0.002	100
red	E220-C 1	2CCE000025R0001	7612270	932979	0.002	100
green	E220-D 1	2CCE000035R0001	7612270	933006	0.002	100
yellow	E220-E 1	2CCE000045R0001	7612270	933037	0.002	100
black	E220-F 1	2CCE000055R0001	7612270	933051	0.002	100
blue	E220-G 1	2CCE000065R0001	7612270	933075	0.002	100

Spare buttons for E227 indicator lamps

Button's colour	Order details	Bbn	Price	Price	Weight	Pack
	Type code	Order code	7612270	1 piece	group	1 piece
					kg	pc.
transparent	E220-B	2CCE000075R0011	7612270	932931	0.002	100
red	E220-C	2CCE000025R0011	7612270	932962	0.002	100
green	E220-D	2CCE000035R0011	7612270	932993	0.002	100
yellow	E220-E	2CCE000045R0011	7612270	933020	0.002	100
blue	E220-G	2CCE000065R0011	7612270	933068	0.002	100

Spare hoods for E229 indicator lamps

Hood's colour	Order details	Bbn	Price	Price	Weight	Pack
	Type code	Order code	7612270	1 piece	group	1 piece
					kg	pc.
transparent	E220-B 3	2CCE000075R0021	7612270	932955	0.002	100
red	E220-C 3	2CCE000025R0021	7612270	932986	0.002	100
green	E220-D 3	2CCE000035R0021	7612270	933013	0.002	100
yellow	E220-E 3	2CCE000045R0021	7612270	933044	0.002	100
blue	E220-G 3	2CCE000065R0021	7612270	933082	0.002	100

7

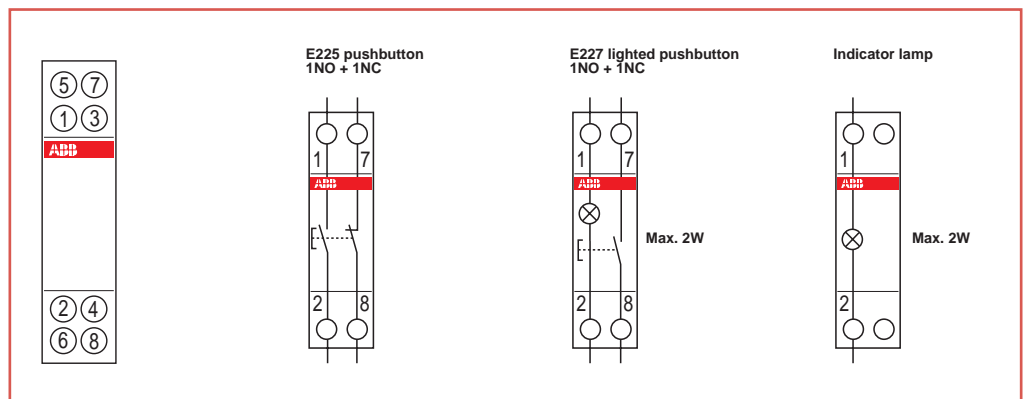

Spare bulbs

Rated voltage	Order details		Bbn 4012233	Price 1 piece	Price group	Weight 1 piece	Pack unit
V	Type code	Order code	EAN			kg	pc.
12 AC	E 10/12	2CCE300005R0001	631605			0.004	100
24 AC	E 10/24	2CCE400005R0001	631803			0.004	100
48 AC	E 10/48	2CCE500005R0001	632008			0.004	100
60 AC	E 10/60	2CCE700005R0001	632107			0.004	100
110 AC	E 10/110	2CCE800005R0001	632206			0.003	100
230 AC	E 10/230	2CCE100005R0001	983704			0.003	100
220 DC	E 10/220	2CCE900005R0001	667307			0.003	100

Lamp driver

	Order details		Bbn 4011395	Price 1 piece	Price group	Weight 1 piece	Pack unit
	Type code	Order code	EAN			kg	pc.
	E 220-LZ	2CCE000005R0001	002902			0.002	10



For loads to be automatically controlled through high number of operations; i.e, building automation, controlling of small pumps, ventilations, heating systems, lighting systems, and so on.

ESB series contactors

The series consists of various models differing in the number of contacts, rated current and control circuit voltage.

ESB contactors (20 A)

Number of contacts	Command circuit's rated voltage U _c	Order details		Bbn	Price 1 piece	Price group	Weight 1 piece	Pack unit
		Type code	Order code	401361				
VAC		Type code	Order code	EAN			kg	pc.
1NO+1NC	12	ESB20-11/12	GHE3211302R1004	1231148			0.200	10
1NO+1NC	24	ESB20-11/24	GHE3211302R0001	0263515			0.200	10
1NO+1NC	48	ESB20-11/48	GHE3211302R0003	0263539			0.200	10
1NO+1NC	110	ESB20-11/110	GHE3211302R0004	1231049			0.200	10
1NO+1NC	230	ESB20-11/230	GHE3211302R0006	0263560			0.200	10
<hr/>								
2NC	12	ESB20-02/12	GHE3211202R1004	1232145			0.200	10
2NC	24	ESB20-02/24	GHE3211202R0001	0236812			0.200	10
2NC	48	ESB20-02/48	GHE3211202R0003	0263836			0.200	10
2NC	110	ESB20-02/110	GHE3211202R0004	1232046			0.200	10
2NC	230	ESB20-02/230	GHE3211202R0006	0263867			0.200	10
<hr/>								
2NO	12	ESB20-20/12	GHE3211102R1004	1230141			0.200	10
2NO	24	ESB20-20/24	GHE3211102R0001	0263218			0.200	10
2NO	48	ESB20-20/48	GHE3211102R0003	0263232			0.200	10
2NO	110	ESB20-20/110	GHE3211102R0004	1230042			0.200	10
2NO	230	ESB20-20/230	GHE3211102R0006	0263263			0.200	10

ESB24 contactors (24 A)

Number of contacts	Command circuit's rated voltage U _c	Order details		Bbn	Price 1 piece	Price group	Weight 1 piece	Pack unit
		Type code	Order code	401361				
VAC		Type code	Order code	EAN			kg	pc.
4NO	12	ESB24-40/12	GHE3291102R1004	4084478			0.280	5
4NO	24	ESB24-40/24	GHE3291102R0001	4084416			0.280	5
4NO	230	ESB24-40/230	GHE3291102R0006	4084454			0.280	5

Technical characteristics

		ESB 20	ESB 24
Rated voltage U _n	[V]	a.c. 230	a.c. 400
Rated current I _n in AC1	[A]	20	24
Rated power in AC3	[kW]		
	230V	1.3	2.2
	400V	-	4
Rated frequency	[Hz]	50/60	40/450
Control circuit voltage	[V]	a.c. 12, 24, 48, 110, 230	a.c./d.c. 12, 24, 230
Mechanic operations	[No]	1 million	1 million
Electric operations			
in AC1	[No]	150,000	130,000
in AC3	[No]	150,000	500,000
Power consumption	[W]	1 per pole	1, 2 per pole
Modules	[No]	1	2
Standards		IEC 60947-4-1	IEC 60947-4-1
		IEC 61095	IEC 61095



ESB40 contactors (40 A)

Number of contacts	Command circuit's rated voltage U _c	Order details		Bbn 401361	Price 1 piece	Price group	Weight 1 piece	Pack unit
		Type code	Order code					
4NO	24	ESB40-40/24	GHE3491102R0001	4084829			0.450	1
4NO	230	ESB40-40/230	GHE3491102R0006	4084867			0.450	1

ESB63 contactors (63 A)

4NO	24	ESB63-40/24	GHE3691102R0001	4084935			0.450	1
4NO	230	ESB63-40/230	GHE3691102R0006	4084973			0.450	1

Auxiliary elements and accessories available for ESB24/40/63, EN24/40

Order details		Bbn 401361	Price 1 piece	Price group	Weight 1 piece	Pack unit
Type code	Order code					

Auxiliary elements

2NO	EH 04-20	GHE3401321R0001	4084768	0.230	1
1NO+1NC	EH 04-11	GHE3401321R0002	4084775	0.230	1

Other accessories

Spacer	ESB-DIS	GHE3201902R0001	4085215	0.002	10
Terminal covers for ESB24	ESB-PLK 24	GHE3201903R0001		0.003	10
Terminal covers for ESB40/63	ESB-PLK 40/63	GHE3401903R0001	4085277	0.003	10

Technical characteristics

		ESB 40	ESB 63
Rated voltage U _n	[V]	a.c. 400	a.c.400
Rated current I _n in AC1	[A]	40	63
Rated power in AC3	[kW]		
230V		5.5	8.5
400V		11	15
Rated frequency	[Hz]	40/450	40/450
Control circuit voltage	[V]	a.c./d.c. 24, 230	a.c./d.c. 24, 230
Mechanic operations	[No]	1 million	1 million
Electric operations			
in AC1	[No]	150,000	150,000
in AC3	[No]	170,000	240,000
Power consumption	[W]	3 per pole	6 per pole
Modules	[No]	3	3
Standards		IEC 60947-4-1	IEC 60947-4-1
		IEC 61095	IEC 61095

Technical characteristics of the auxiliary contact

Thermal current I _{th}	[A]	6
Operating rated current I _e AC15 a		
< 240V a.c.	[A]	4
< 380/415V a.c.	[A]	3
< 500V a.c.	[A]	2
Minimum load		12V 300mA



EN series contactors

Equipped with front switch to select operation mode (override): permanent OFF, automatic operation, manual ON.

EN20 contactors (20 A)

Number of contacts	Command circuit's rated voltage U_c	Order details		Bbn	Price	Price group	Weight	Pack unit
		Type code	Order code	EAN	1 piece		1 piece	kg
2NO	230	EN20-20/230	GHE3221101R0006	347152			0.280	1

EN24 contactors (24 A)

Number of contacts	Command circuit's rated voltage U_c	Order details		Bbn	Price	Price group	Weight	Pack unit
		Type code	Order code	EAN	1 piece		1 piece	kg
3NO	230	EN24-30/230	GHE3261501R0006	401361			0.280	1
4NO	230	EN24-40/230	GHE3261101R0006	413368			0.280	1

EN40 contactors (40 A)

2NO	230	EN40-20/230	GHE3421401R0006	412958			0.450	1
3NO	230	EN40-30/230	GHE3421501R0006				0.450	1
4NO	230	EN40-40/230	GHE3421101R0006	413370			0.450	1

Technical characteristics

		EN 20	EN 24	EN 40
Rated voltage U_n	[V]	a.c. 230/400	a.c. 230/400	a.c. 230/400
Rated current I_n in AC1	[A]	20	24	40
Rated output in AC3				
230	[kW]	1.3	2.2	5.5
400	[kW]	-	4	11
Rated frequency	[Hz]	50/60	40/450	40/450
Control circuit voltage	[V]	a.c. 230		
Power consumption	[W]	1 per pole	1.2 per pole	3 per pole
Modules	[No]	1	2	3
Standards		IEC/EN 61095	IEC/EN 61095	IEC/EN 61095
Approvals		UTE		

E 234 electronic timers

Rated control voltage	Control input	Order details	Bbn	Price 1 piece	Price group	Weight 1 piece	Pack unit
V		Type code	Order code	EAN		kg	pc.

Multifunction timers

E 234 CT-MFD: 7 functions ¹⁾, 7 time ranges (0.05 s- 100 h), 2 c/o contacts, 2 LEDs

12-240 AC/DC	yes	E 234 CT-MFD.21	1SVR 500 020 R1100			0.065	1
--------------	-----	-----------------	--------------------	--	--	-------	---

E 234 CT-MFD: 7 functions ¹⁾, 7 time ranges (0.05 s- 100 h), 1 c/o contact, 2 LEDs

24-48 DC, 24-240 AC	yes	E 234 CT-MFD.12	1SVR 500 020 R0000			0.060	1
------------------------	-----	-----------------	--------------------	--	--	-------	---

ON-delay timers 

E 234 CT-ERD: 7 time ranges (0.05 s- 100 h), 2 c/o contacts, 2 LEDs

24-48 DC, 24-240 AC		E 234 CT-ERD.22	1SVR 500 100 R0100			0.065	1
------------------------	--	-----------------	--------------------	--	--	-------	---

E 234 CT-ERD: 7 time ranges (0.05 s- 100 h), 1 c/o contact, 2 LEDs

24-48 DC, 24-240 AC		E 234 CT-ERD.12	1SVR 500 100 R0000			0.060	1
------------------------	--	-----------------	--------------------	--	--	-------	---

OFF-delay timers 

E 234 CT-AHD: 7 time ranges (0.05 s- 100 h), 2 c/o contacts, 2 LEDs

24-48 DC, 24-240 AC	yes	E 234 CT-AHD.22	1SVR 500 110 R0100			0.065	1
------------------------	-----	-----------------	--------------------	--	--	-------	---

E 234 CT-AHD: 7 time ranges (0.05 s- 100 h), 1 c/o contact, 2 LEDs

24-48 DC, 24-240 AC	yes	E 234 CT-AHD.12	1SVR 500 110 R0000			0.060	1
------------------------	-----	-----------------	--------------------	--	--	-------	---

¹⁾ Functions: ON-delay, OFF-delay with auxiliary voltage, Impulse-ON, Impulse-OFF with auxiliary voltage, Flasher starting with ON, Flasher starting with OFF, Pulseformer

2CDDC 251 089 F0b06



2CDDC 251 088 F0b06



2CDDC 251 092 F0b06



2CDDC 251 093 F0b06



2CDC 251 095 F0006



2CDC 251 096 F0006



2CDC 251 098 F0006



2CDC 251 099 F0006



Rated control voltage	Control input	Order details	Bbn	Price 1 piece	Price group	Weight 1 piece	Pack unit
V		Type code	Order code	EAN		kg	pc.

Impulse-ON

E 234 CT-VWD: 7 time ranges (0.05 s- 100 h), 1 c/o contact, 2 LEDs

24-48 V DC, 24-240 V AC		E 234 CT-VWD.12	1SVR 500 130 R0000			0.060	1
----------------------------	--	-----------------	--------------------	--	--	-------	---

Flasher, starting with the ON time

E 234 CT-EBD: 7 time ranges (0.05 s- 100 h), 1 c/o contact, 2 LEDs

24-48 V DC, 24-240 V AC		E 234 CT-EBD.12	1SVR 500 150 R0000			0.060	1
----------------------------	--	-----------------	--------------------	--	--	-------	---

Pulse generators

E 234 CT-TGD: 2x7 time ranges (0.05 s- 100 h)²⁾, 2 c/o contacts, 2 LEDs

24-48 V DC, 24-240 V AC	yes	E 234 CT-TGD.22	1SVR 500 160 R0100			0.065	1
----------------------------	-----	-----------------	--------------------	--	--	-------	---

E 234 CT-TGD: 2x7 time ranges (0.05 s- 100 h)²⁾, 1 c/o contact, 2 LEDs

24-48 V DC, 24-240 V AC	yes	E 234 CT-TGD.12	1SVR 500 160 R0000			0.060	1
----------------------------	-----	-----------------	--------------------	--	--	-------	---

Star-delta change-over

E 234 CT-SDD: 4 time ranges (0.05 s- 10 min), transition time 50 ms fixed, 2 n/o contacts, 3 LEDs

24-48 V DC, 24-240 V AC		E 234 CT-SDD.22	1SVR 500 211 R0100			0.065	1
----------------------------	--	-----------------	--------------------	--	--	-------	---

E 234 CT-SAD: 4 time ranges (0.05 s- 10 min), transition time adjustable, 2 n/o contacts, 3 LEDs

24-48 V DC, 24-240 V AC		E 234 CT-SAD.22	1SVR 500 210 R0000			0.065	1
----------------------------	--	-----------------	--------------------	--	--	-------	---

²⁾ ON and OFF times adjustable independently,
2x7 time ranges 0.05 s - 100 h

Technical data

Data at Ta = 25 °C and rated values, if nothing else indicated

Type	CT-D with 1 c/o contact		CT-D with 2 c/o contacts
Input circuit - Supply circuit			
Rated control supply voltage U _s	A1-A2	24-240 V AC / 24-48 V DC	
	A1-A2	-	12-240 V AC/DC (CT-MFD.21)
Rated control supply voltage U _s tolerance	-15...+10 %		
Rated frequency	AC/DC versions	DC or 50/60 Hz	
	AC versions	50/60 Hz	
Frequency range	AC/DC versions	DC or 47/63 Hz	
	AC versions	47/63 Hz	
Typical power consumption	24 V DC	0.6 W	on request
	230 V AC	1.3 VA	on request
	115 V AC	1.3 VA	on request
Power failure buffering time	min. 20 ms		min. 30 ms



Input circuit - Control circuit

Voltage-related triggering			
Control input, Control function	A1-Y1/B1	start timing external	
Maximum cable length to the control input	50 m - 100 pF/m		
Minimum control pulse length	30 ms		
Control voltage potential	see rated control supply voltage		
Current consumption of the control input	max. 4 mA		on request
Parallel load / polarized	yes / yes		

Timing circuit

Time ranges	7 time ranges 0.05 s - 100 h	1.) 0.05-1 s	2.) 0.5-10 s	3.) 5-100 s	4.) 0.5-10 min	5.) 5-100 min	6.) 0.5-10 h	7.) 5-100 h
	4 time ranges 0.05 s - 10 min (CT-SDD, CT-SAD)	1.) 0.05-1 s	2.) 0.5-10 s	3.) 5-100 s	4.) 0.5-10 min			
Recovery time	< 50 ms							
Repeat accuracy (constant parameters)	$\Delta t < \pm 0.5 \%$							
Accuracy within the rated control supply voltage tolerance	$\Delta t < 0.005 \%$ / V							
Accuracy within the temperature range	$\Delta t < 0.06 \%$ / °C							
Star-delta transition time	CT-SDD	fixed 50 ms						
	CT-SAD	adjustable: 20-100 ms in steps of 10 ms						
Star-delta transition time tolerance	CT-SDD, CT-SAD	$\pm 3 \text{ ms}$						

Indication of operational states

Control supply voltage / timing	U: green LED	 : control supply voltage applied
		 : timing
Relay status	R: yellow LED	 : output relay 1 or 2 energized

Output circuit

Kind of output	15-16/18	relay, 1 c/o contact	-
	15-16/18; 25-26/28	-	relay, 2 c/o contacts
	17-18; 17-28	relay, 2 n/o contacts (CT-SDD, CT-SAD)	
Contact material	Cd-free, see data sheet		
Rated operational voltage U _e	250 V		
Minimum switching voltage / minimum switching current	12 V / 100 mA		
Maximum switching voltage / maximum switching current	see load limit curves		
Rated operational current I _e (IEC 60947-5-1) for category	AC12 (resistive) at 230 V	6 A	5 A
	AC15 (inductive) at 230 V	3 A	3 A ¹⁾
	DC12 (resistive) at 24 V	6 A	5 A
	DC13 (inductive) at 24 V	2 A	3 A ¹⁾
Mechanical lifetime	30 x 10 ⁶ switching cycles		
Electrical lifetime	at AC12, 230 V, 4 A	0.1 x 10 ⁶ switching cycles	
Short-circuit proof / maximum fuse rating (IEC/EN 60947-5-1)	n/c contact	6 A fast-acting	
	n/o contact	10 A fast-acting	

¹⁾ CT-MFD.2x on request

Technical data

Data at Ta = 25 °C and rated values, if nothing else indicated

Type	CT-D with 1 c/o contact		CT-D with 2 c/o contacts
General data			
Duty time	100%		
Dimensions (W x H x D)	17.5 mm x 70 mm x 58 mm (0.69 x 2.76 x 2.28 inches)		17.5 mm x 80 mm x 58 mm (0.69 x 3.15 x 2.28 inches)
Weight	see ordering details		
Mounting	DIN rail (EN 60715), snap-mounting without any tool		
Mounting position	any		
Minimum distance to other units horizontal / vertical	no / no		
Degree of protection enclosure / terminals	IP50 / IP20		
Electrical connection			
Wire size	fine-strand	with wire end ferrule	2 x 0.5-1.5 mm ² (2 x 20-16 AWG) 1 x 0.5-2.5 mm ² (1 x 20-14 AWG)
		without wire end ferrule	2 x 0.5-1.5 mm ² (2 x 20-16 AWG) 1 x 0.5-2.5 mm ² (1 x 20-14 AWG)
	rigid		2 x 0.5-1.5 mm ² (2 x 20-16 AWG) 1 x 0.5-4 mm ² (1 x 20-12 AWG)
Stripping length	7 mm (0.28 inches)		
Tightening torque	0.5-0.8 Nm		
Environmental data			
Ambient temperature range	operation	-20 ... +60 °C	
	storage	-40 ... +85 °C	
Damp heat (cyclic) (IEC/EN 60068-2-30)	6 x 24 h cycles, 55 °C, 95 % RH		
Vibration (sinusoidal) (IEC/EN 60068-2-6)	40 m/s ² , 20 cycles, 10...150...10 Hz		
Shock (half-sine) (IEC/EN 60068-2-27)	100 m/s ² , 11 ms		
Isolation data			
Rated impulse withstand voltage U _{imp} between all isolated circuits (VDE 0110, IEC/EN 60664-1)	4 kV; 1.2/50 μs		
Pollution category (IEC/EN 60664-1, VDE 0110, UL 508)	3		
Overvoltage category (IEC/EN 60664-1, VDE 0110, UL 508)	III		
Rated insulation voltage U _i	input circuit / output circuit	300 V	
	output circuit 1 / output circuit 2	300 V	
Basic insulation (IEC/EN 61140) input circuit / output circuit	300 V		
Protective separation input circuit / output circuit (VDE 0106 part 101 and part 101/A1; IEC/EN 61140)	250 V		
Test voltage between all isolated circuits (type test)	2.5 kV, 50 Hz, 1 s		
Standards			
Product standard	IEC 61812-1, EN 61812-1 + A11, DIN VDE 0435 part 2021		
Low Voltage Directive	2006/95/EC		
EMC Directive	2004/108/EC		
RoHS Directive	2002/95/EC		
Electromagnetic compatibility			
Interference immunity	IEC/EN 61000-6-1, IEC/EN 61000-6-2		
electrostatic discharge (ESD)	IEC/EN 61000-4-2	Level 3 (6 kV / 8 kV)	
electromagnetic field (HF radiation resistance)	IEC/EN 61000-4-3	Level 3 (10 V/m)	
fast transients (Burst)	IEC/EN 61000-4-4	Level 3 (2 kV / 5 kHz)	
powerful impulses (Surge)	IEC/EN 61000-4-5	Level 4 (2 kV L-L)	
HF line emission	IEC/EN 61000-4-6	Level 3 (10 V)	
Interference emission	IEC/EN 61000-6-3, IEC/EN 61000-6-4		
electromagnetic field (HF radiation resistance)	IEC/CISPR 22, EN 55022	B	
HF line emission	IEC/CISPR 22, EN 55022	B	

Technical diagrams

Load limit curves

AC load (resistive)

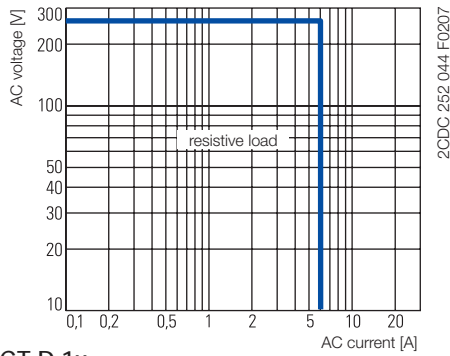

CT-D.1x

DC load (resistive)

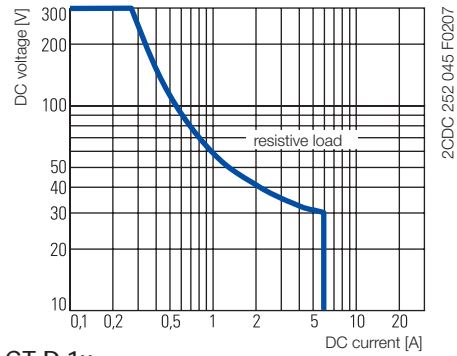

CT-D.1x

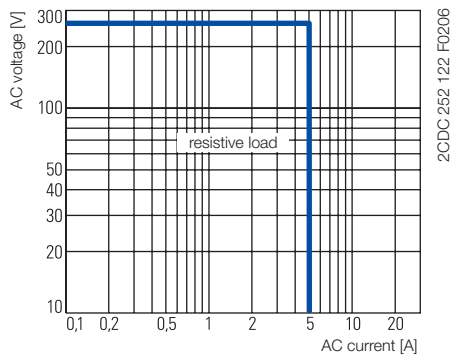

CT-D.2x

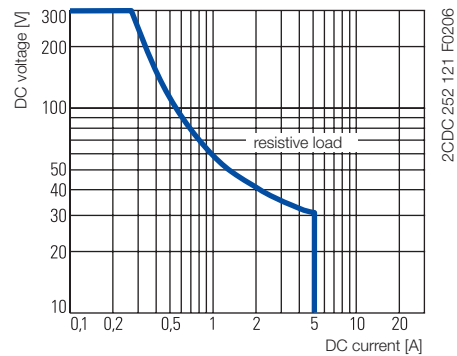

CT-D.2x

Derating factor F

for inductive AC load

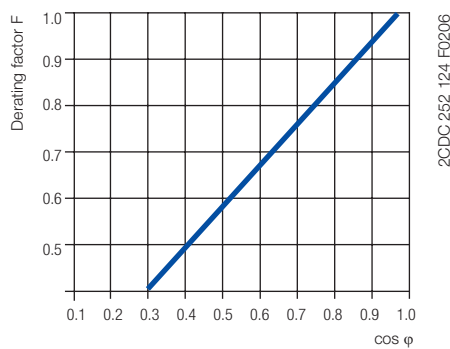

Contact lifetime

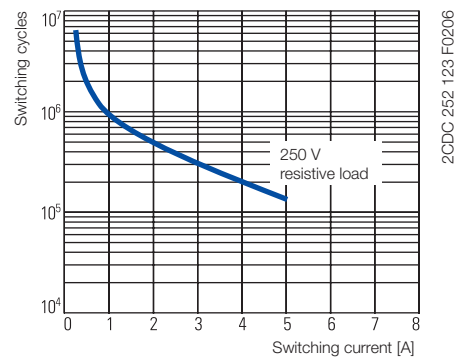

7

Connection diagrams

CT-MFD.21

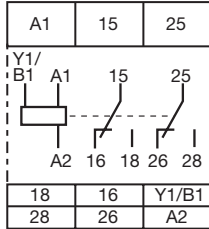

2CDC 252 113 F0b06

CT-MFD.12

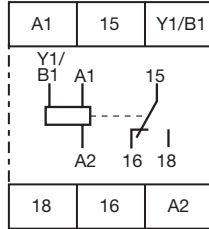

2CDC 252 114 F0b06

☒ CT-ERD.22

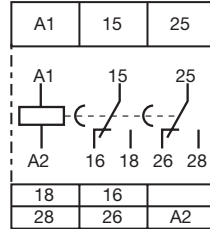

2CDC 252 115 F0b06

☒ CT-ERD.12

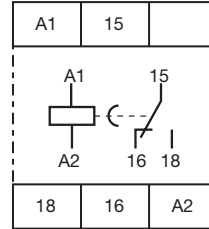

2CDC 252 177 F0b05

■ CT-AHD.22

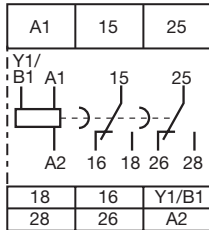

2CDC 252 116 F0b06

■ CT-AHD.12

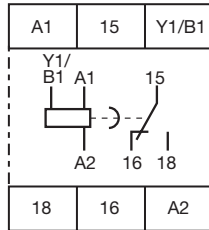

2CDC 252 117 F0b06

1 □ ☒ CT-VWD.12

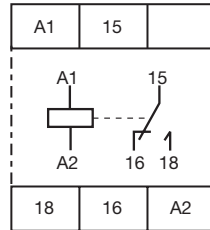

2CDC 252 179 F0b05

1 □ ☒ CT-EBD.12

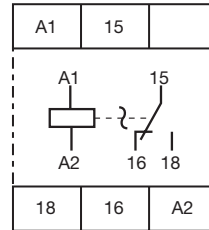

2CDC 252 180 F0b05

☒ □ CT-TGD.22

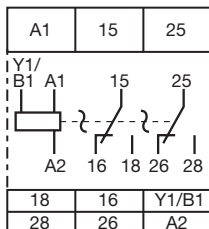

2CDC 252 118 F0b06

☒ □ CT-TGD.12

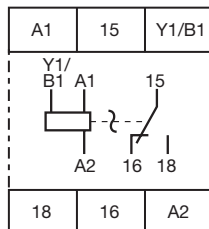

2CDC 252 119 F0b06

△ CT-SDD.22

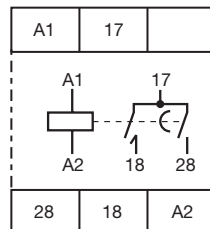

2CDC 252 160 F0b06

△ CT-SAD.22

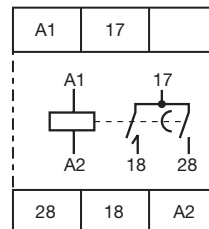

2CDC 252 160 F0b06

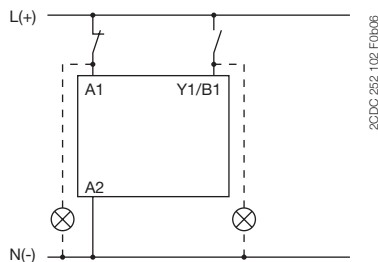

Wiring notes for devices with control input

A parallel load to the control input is possible



Remarks

Legend

-  Control supply voltage not applied / Output contact open
-  Control supply voltage applied / Output contact closed
- A1-Y1/B1 Control input with voltage-related triggering

Terminal designations on the device and in the diagrams

The 1st c/o contact is always designated 15-16/18.
 The 2nd c/o contact is designated 25-26/28.
 The n/o contacts of the star-delta timers are designated with 17-18 and 17-28.
 Control supply voltage is always applied to terminals A1-A2.

Function of the yellow LED

The yellow LED R glows as soon as the output relay energizes and turns off when the output relay de-energizes.

-  **ON-delay**
 (Delay on make)
 CT-ERD, CT-MFD

This function requires continuous control supply voltage for timing. Timing begins when control supply voltage is applied. The green LED flashes during timing. When the selected time delay is complete, the output relay energizes and the flashing green LED turns steady. If control supply voltage is interrupted, the output relay de-energizes and the time delay is reset. Control input A1-Y1/B1 of the CT-MFD is disabled when this function is selected.

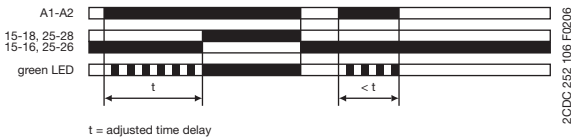

-  **OFF-delay with auxiliary voltage**
 (Delay on break)
 CT-AHD, CT-MFD

This function requires continuous control supply voltage for timing. If control input A1-Y1/B1 is closed, the output relay energizes immediately. If control input A1-Y1/B1 is opened, the time delay starts. The green LED flashes during timing. When the selected time delay is complete, the output relay de-energizes and the flashing green LED turns steady. If control input A1-Y1/B1 recloses before the time delay is complete, the time delay is reset and the output relay does not change state. Timing starts again when control input A1-Y1/B1 re-opens. If control supply voltage is interrupted, the output relay de-energizes and the time delay is reset.

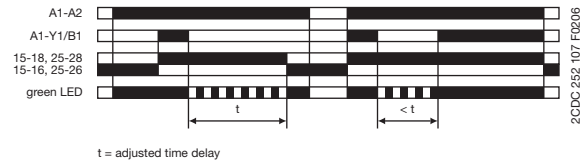

7

-  **Impulse-ON**
 (Interval)
 CT-VWD, CT-MFD

This function requires continuous control supply voltage for timing. The output relay energizes immediately when control supply voltage is applied and de-energizes after the set pulse time is complete. The green LED flashes during timing. When the selected pulse time is complete, the flashing green LED turns steady. If control supply voltage is interrupted, the output relay de-energizes and the time delay is reset. Control input A1-Y1/B1 of the CT-MFD is disabled when this function is selected.

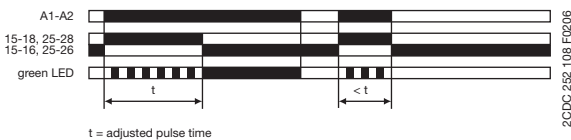

-  **Impulse-OFF with auxiliary voltage**
 (Trailing edge interval)
 CT-MFD

This function requires continuous control supply voltage for timing. If control supply voltage is applied, opening control input A1-Y1/B1 energizes the output relay immediately and starts timing. The green LED flashes during timing. When the selected pulse time is complete, the output relay de-energizes and the flashing green LED turns steady. Closing control input A1-Y1/B1, before the time delay is complete, de-energizes the output relay and resets the time delay. If control supply voltage is interrupted, the output relay de-energizes and the time delay is reset.

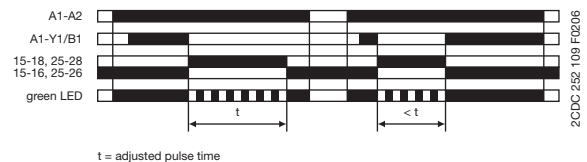

-  **Flasher, starting with the ON time**
 (Recycling equal times, ON first)
 CT-EBD, CT-MFD

Applying control supply voltage starts timing with symmetrical ON & OFF times. The cycle starts with an ON time first. The ON & OFF times are displayed by the flashing green LED, which flashes twice as fast during the OFF time. If control supply voltage is interrupted, the output relay de-energizes and the time delay is reset. Control input A1-Y1/B1 of the CT-MFD is disabled when this function is selected.

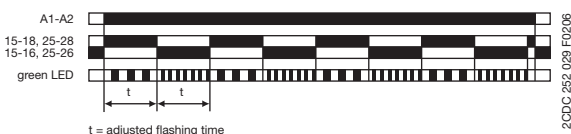

-  **Flasher, starting with the OFF time**
 (Recycling equal times, OFF first)
 CT-MFD

Applying control supply voltage starts timing with symmetrical ON & OFF times. The cycle starts with an OFF time first. The ON & OFF times are displayed by the flashing green LED, which flashes twice as fast during the OFF time. If control supply voltage is interrupted, the output relay de-energizes and the time delay is reset. Control input A1-Y1/B1 of the CT-MFD is disabled when this function is selected.

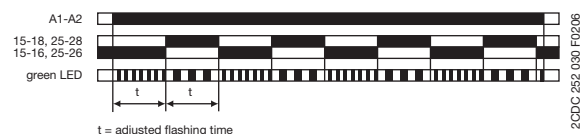

 **Pulse former (Single shot)**
CT-MFD

This function requires continuous control supply voltage for timing. Closing control input A1-Y1/B1 energizes the output relay immediately and starts timing. Operating the control contact switch A1-Y1/B1 during the time delay has no effect. The green LED flashes during timing. When the selected ON time is complete, the output relay de-energizes and the flashing green LED turns steady. After the ON time is complete, it can be restarted by closing control input A1-Y1/B1. If control supply voltage is interrupted, the output relay de-energizes and the time delay is reset.

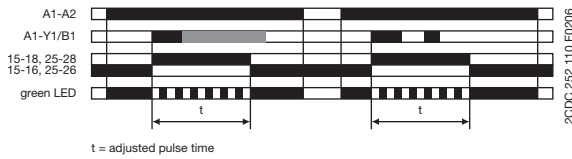

 **Pulse generator, starting with the ON or OFF time (Recycling unequal times, ON or OFF first)**
CT-TGD

This function requires continuous control supply voltage for timing. Applying control supply voltage, with open control input A1-Y1/B1, starts timing with an ON time first. Applying control supply voltage, with closed control input A1-Y1/B1, starts timing with an OFF time first. The ON & OFF times are displayed by the flashing green LED, which flashes twice as fast during the OFF time. The ON & OFF times are independently adjustable. If control supply voltage is interrupted, the output relay de-energizes and the time delay is reset.

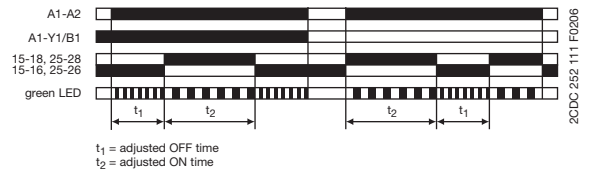

 **Star-delta change-over (Star-delta starting)**
CT-SDD, CT-SAD

This function requires continuous control supply voltage for timing. Applying control supply voltage to terminals A1-A2, energizes the star contactor connected to terminals 17-18 and begins the set starting time t_1 . The green LED flashes during timing. When the starting time is complete, the first output contact de-energizes the star contactor. Now, the transition time t_2 starts. When the transition time is complete, the second output contact energizes the delta contactor connected to terminals 17-28. The delta contactor remains energized as long as control supply voltage is applied to the unit.

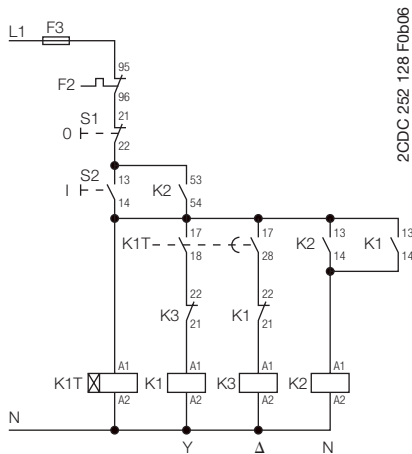
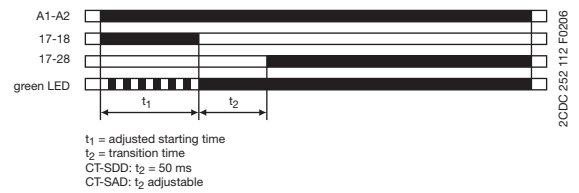

Control circuit diagram

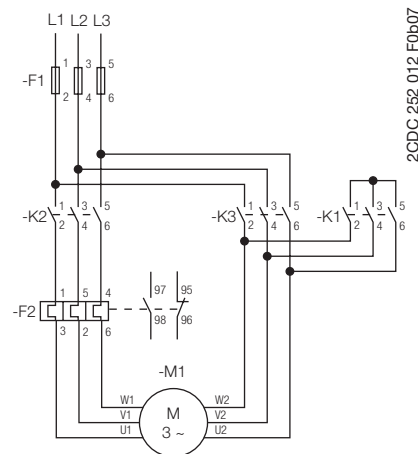

Power circuit diagram

E 232 staircase lighting time-delay switches



E 232 staircase lighting time-delay switches

Staircase lighting time-delay switches are usually operated by pushbuttons, often fitted with a filament lamp. Switches are designed for a filament lamp current of up to 150 mA and thus perfectly suitable for installations in multi-storey buildings.

The E 232-230 staircase lighting time-delay switch includes an electro-mechanical timer with a synchronous motor drive to ensure high operational safety in whatever mounting position. The time range is adjustable in increments of 15 seconds from 1 to seven minutes. Can be connected in series after 30 seconds.

E 232E-230N and E 232E-8/230N devices feature electronic time delays. A high switching capacity, 150 mA filament lamp current parallel to the pushbuttons, steplessly adjustable time range from 0.5 to 20 min, as well as low switching noise make these devices so special.

Devices of the E 232E-230 Multi 10 and E 232E-8/230 Multi 10 series are multi-functional products with 10 functions to choose from that can be adjusted from the front. Through an electronically controlled connection of the load at voltage zero, a very high switching capacity of 3,600 W (load of glow lamp) is reached.

The devices include an integrated warning feature (warning by blinking) according to DIN 18015-2 as well as a 60 minute long-time function.

The E 232E-8/230N and E 232E-8/230 Multi 10 staircase lighting time-delay switches offer an additional metallically separated control input for 8 ... 240 V AC/DC.

The electronic E 232-HLM half-light module is a supplementary device for staircase lighting time-delay switches for semi-light control according to DIN 18015-2. The module switches glow lamps and 230 V halogen lamps up to 2,300 W in the warning phase to an output voltage that is reduced by 50%. Adjustable time range from 20 – 60 seconds.

Technical features

	E 232-230	E 232E-230N	E 232E-8/230N	E 232E-230 Multi 10	E 232E-8/230 Multi 10	E 232E-HLM
Time range (stepless)	1 – 7 min. in 15 sec. increments	0.5 – 20 min. stepless	0.5 – 20 min. stepless	0.5 – 20 min. stepless	0.5 – 20 min. stepless	20 – 60 sec. stepless
Control voltage 230 V AC	■	■	■	■	■	■
Universal voltage in addition			8 ... 240 V AC/DC		8 ... 240 V AC/DC	
Filament lamp current	50 mA	150 mA	150 mA	150 mA	150 mA	
3/4 conductor operated	switches	automatically	automatically	automatically	automatically	
Can be connected in series	■	■	■	■	■	
Steady-light switch	■	■	■	■	■	
Advance warning acc. DIN 18015-2				■	■	■
Long-time range of 60 min.				■	■	
Multi-functional device (10 functions)				■	■	
Glow lamp load	2,30	2,30	2,30	3,60	3,60	2,30
Rated voltage	230 V AC	240 V AC	240 V AC	240 V AC	240 V AC	240 V AC
	50 Hz	50 / 60 Hz	50 / 60 Hz	50 / 60 Hz	50 / 60 Hz	50 / 60 Hz
Control voltage range	0.9 ... 1.1 Un	0.85 ... 1.1 Un	0.85 ... 1.1 Un	0.85 ... 1.1 Un	0.85 ... 1.1 Un	0.9 ... 1.1 Un
Power loss	1 VA	6 VA	6 VA	6 VA	6 VA	6 VA
Rated switching capacity	16 A, 230 V AC	16 A, 230 V AC	16 A, 230 V AC	16 A, 230 V AC	16 A, 230 V AC	10 A, 230 V AC
Glow lamp load	2,30	2,30	2,30	3,60	3,60	2,30
Halogen lamp load	2,30	2,30	2,30	3,600 W	3,60	2,30
Fluorescent lamps series compensated / uncorrected	2,300	2,300	2,300	3,600 VA *	3,600 VA *	not permitted
Fluorescent lamps inductive or capacitive	2,300	2,300	2,300	3,600 VA *	3,600 VA *	not permitted
Fluorescent lamps shunt compensated	1300 VA (70 µF)	400 VA (42 µF)	400 VA (42 µF)	1200 VA (120 µF) *	1200 VA (120 µF) *	not permitted
Electronic controlgear	9x7 W, 6x11 W 5x15 W, 5x20 W	9x7 W, 7x11 W, 7x15 W, 7x20 W	9x7 W, 7x11 W, 7x15 W, 7x20 W	34x7 W, 27x11W, 24x15 W, 22x23 W	34x7 W, 27x11W, 24x15 W, 22x23 W	not permitted
Inductive load (cos φ = 0.6/230 V AC)	2,300	2,300	2,300	2,300	2,300	not permitted
Contact material	AgSnO2	AgSnO2	AgSnO2	AgSnO2	AgSnO2	AgSnO2
Contact gap	≥ 3 mm	≥ 0.4 mm	≥ 0.4 mm	≥ 0.4 mm	≥ 0.4 mm	≥ 0.4 mm
Mech. serviceable life	106	107	107	107	107	107
Serviceable life at rated load, cos φ = 1	105	2x105	2x105	2x105	2x105	105
Serviceable life at rated load, cos φ = 0.6	104	4x104	4x104	4x104	4x104	104
Terminal capacity	10.7 mm ²	13 mm ²	13 mm ²	13 mm ²	13 mm ²	13.6 mm ²
Max. conductor capacity	6 mm ²	4 mm ²	4 mm ²	4 mm ²	4 mm ²	6 mm ²
ON duration	can be connected in series after 30 sec.	100 %	100 %	100 %	100 %	100 %
Ambient temperature	- 10 °C to + 50 °C	- 25 °C to + 50 °C	- 25 °C to + 50 °C	- 25 °C to + 50 °C	- 25 °C to + 50 °C	- 10 °C to + 50 °C
Housing and insulation material	heat resistant, self-extinguishing thermoplast	heat resistant, self-extinguishing thermoplast	heat resistant, self-extinguishing thermoplast	heat resistant, self-extinguishing thermoplast	heat resistant, self-extinguishing thermoplast	heat resistant, self-extinguishing thermoplast
Control current at 230 V AC	4.5 mA	26 mA	26 mA	26 mA (min. 8 mA at 8 V AC)	26 mA (min. 8 mA at 8 V AC)	
Minimum command duration	10 ms	20 ms	20 ms	20 ms / 50 ms for multi voltage input	20 ms / 50 ms for multi voltage input	
Filament lamp current	50 mA	150 mA	150 mA	150 mA	150 mA	

* no disconnection advance warning possible for this application.



Time range	Power loss W	Order details Type code	Order code	Bbn 4013614 EAN	Price 1 piece	Price group	Weight 1 piece kg	Pack unit pc.
1 ... 7 min.	1 V A	E 232-230	2CDE 110 000 R0501	54824 3			0.081	10
20 min	6 V A	E 232 E-230N	2CDE 110 003 R0511	65416 6			0.095	10
20 min	6 V A	E 232 E-8/230N	2CDE 010 003 R0511	65417 3			0.1	10
20 min	6 V A	E 232 E-230 Multi 10	2CDE 110 013 R0511	65418 0			0.095	10
20 min	6 V A	E 232 E-8/230 Multi 10	2CDE 010 013 R0511	65419 7			0.1	10
20 ... 60 sec.	6 V A	E 232-HLM	2CDE 150 000 R0521	54828 1			0.075	10

E 232E-230 Multi 10, 8/230 Multi 10

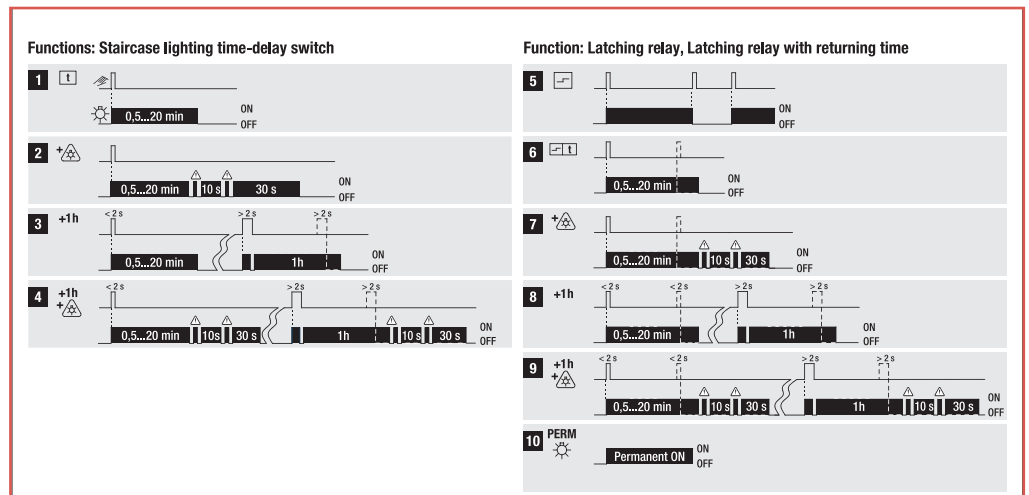

Wiring diagrams

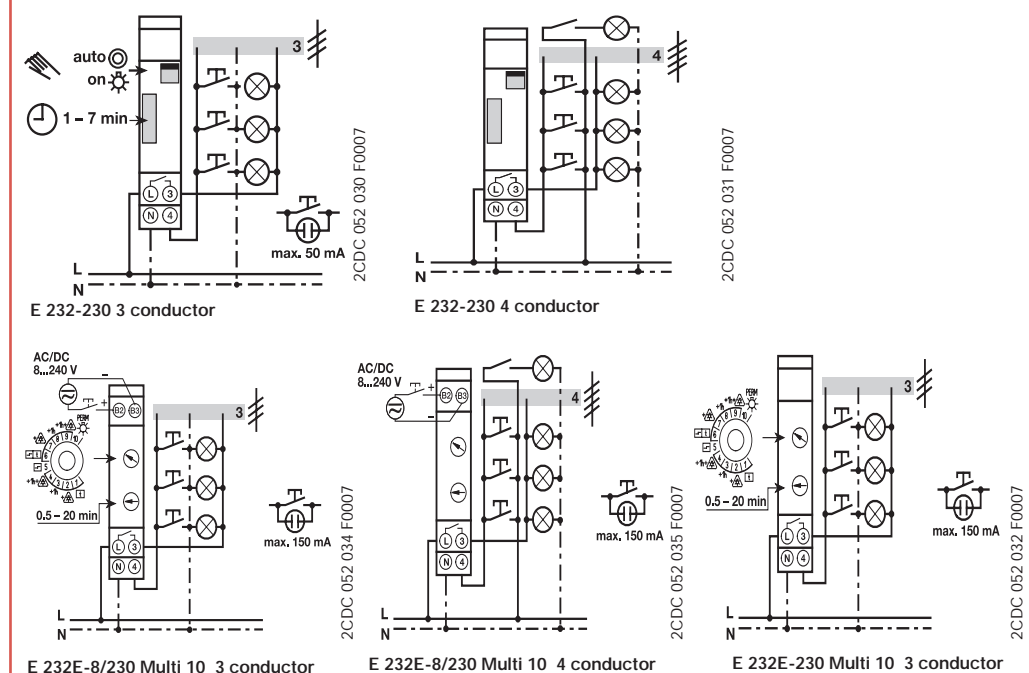

E 232 staircase lighting time-delay switches

Wiring diagrams

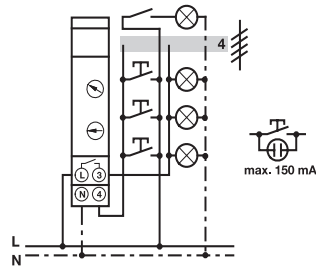

E 232E-230 Multi 10 4 conductor

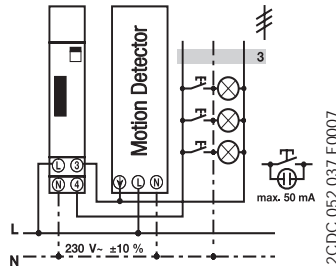

E 232E-8/230 Multi 10 3 conductor
E 232E 8/230 3 conductor
E 232E 230 Multi 10 3 conductor
E 232E 230 N 3 conductor
E 232-230 3 conductor

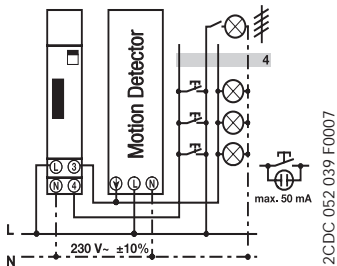

E 232E-8/230 Multi 10 4 conductor
E 232E 8/230 4 conductor
E 232E 230 Multi 10 4 conductor
E 232E 230 N 4 conductor
E 232-230 4 conductor

Staircase lighting time-delay switches E 232 HLM

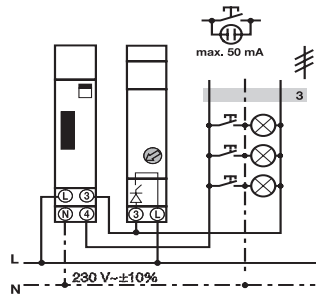

E 232 HLM 3 conductor

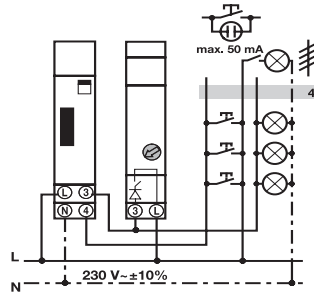

E 232 HLM 4 conductor

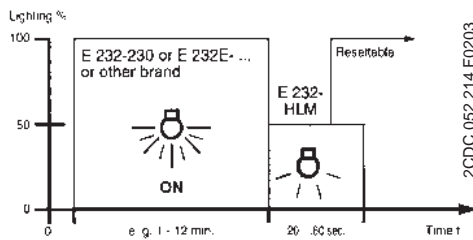

timing of a staircase lighting time-delay switch with semi-light module E 232-HLM

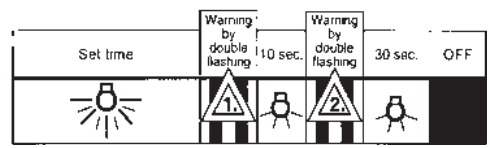

warning function of E 232E-8/230 Plus

DIN 18015-2

provides that "that the automatic disconnection of lighting equipment fitted in staircases of apartment buildings must provide for warning signals, e.g. dimming, in order to avoid sudden unexpected darkness".



STD50 dimmers for the control of lamps and ballast

Description/ application	Power loss	Order details	Bbn 4016779	Price 1 piece	Price group	Weight 1 piece	Pack unit
	W	Type code	Order code	EAN		kg	pc.

Dimmer for brightness control of filament lamps , 230 V tungsten halogen lamps, Iv halogen lamps with conventional transformers (phase control)

5 ①	STD 50-3	GH V021 1370 R0074	02790 8			0.155	1
-----	----------	--------------------	---------	--	--	-------	---

Dimmer for brightness control of filament lamps , 230 V tungsten halogen lamps, Iv halogen lamps with ABB electronic transformers (reverse phase)

4 ①	STD 50-4	GH V021 1370 R0075	03300 8			0.105	1
-----	----------	--------------------	---------	--	--	-------	---

① power loss = 1% of connected load (4 or 5 W max)

Technical features

Rated voltage	230 V ~ 50 Hz
Ambient temperature	0 °C to + 35 °C
Interference suppression	CE

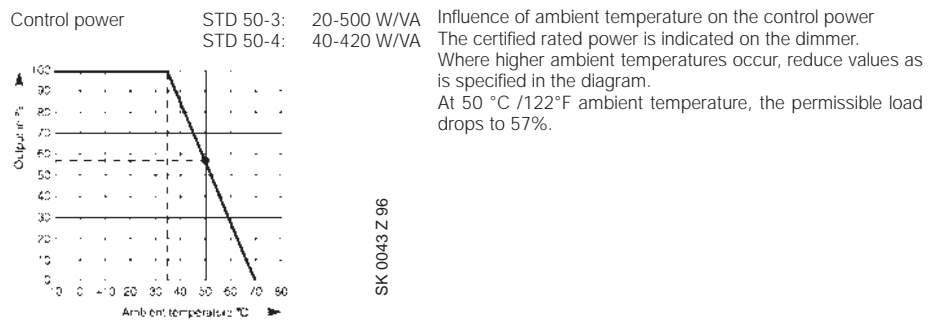



Electronic potentiometer for electronic control gear with control input 0/1 - 10 V DC, control current 50 mA DC

Rated current (terminal 3 and 4) 4 A $\cos\phi = 0.9$; switching capacity 700 VA

Description/ application	Power loss	Order details	Bbn 4016779	Price 1 piece	Price group	Weight 1 piece	Pack unit
	W	Type code	Order code	EAN		kg	pc.
	5 ①	STD-EP	GH V021 1370 R0076	27050 2		0.073	1

Memory touch controller for electronic control gear

Rated voltage/switching output 4 A (~ 10 electronic control gear units) $\cos\phi = 0.9$; 3 A $\cos\phi = 0.5$, switching capacity 700 VA

for electronic control gear with control input 1 - 10 V DC control current 50 mA max.	1	STD-MTS	GH V021 0881 R0004	27070 0		0.110	1
---	---	---------	--------------------	---------	--	-------	---

① power loss = 1% of connected load (7 W max)

7

Electronic potentiometer

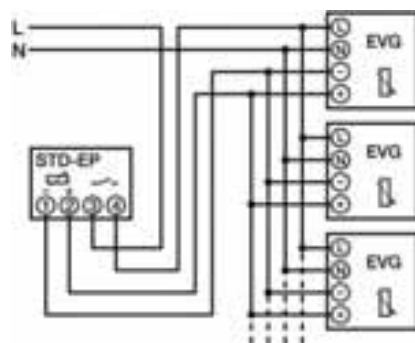

Dimmer STD 50-4 in two-way circuit, 1v halogen lamps via electronic transformer

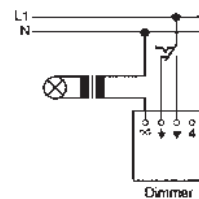

SK 0190 Z 99

Brightness control of fluorescent lamps with 1-10 V control input. Control of more than one memory touch controller STD-MTS via one pushbutton.

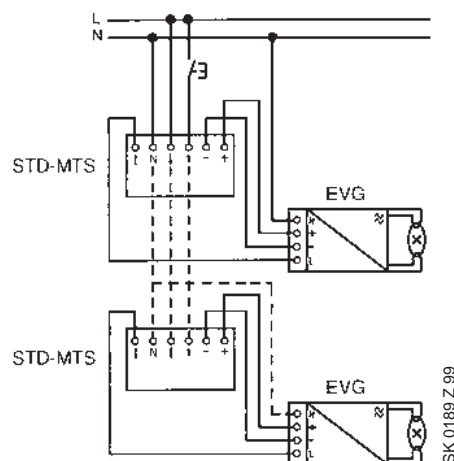

SK 0189 Z 99

Brightness control of a fluorescent lamp with 1-10 V DC control input with memory touch controller STD-MTS with external pushbutton, e.g. E 225

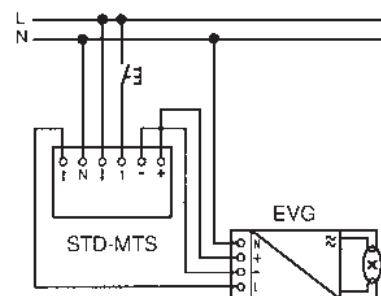

SK 0190 Z 99



Universal dimmer for phase control and reverse phase control

Universal dimmer STD-500 U and the connected power extension unit STD-420 E are suitable for the brightness control of:

- glow lamps
- 230 V halogen glow lamps
- lv halogen glow lamps with conventional transformer (phase control)
- electronic transformers for lv halogen glow lamps (reverse phase control) e.g.: ABB ETR-70-230, 105-230, 150-230

The STD-500 U dimmer can be operated by one or more unlit pushbuttons (N- or L-controlled) or via a data line:

- EIB control element SB/S
- Powernet control element PSB

Power unit STD-420 E is used to boost the connected load and is controlled exclusively by the preset command of the STD-500 U dimmer. The parallel connection of the outputs of the universal high-performance dimmer and the pertaining power extensions (up to 6 units; connection with enclosed RJ 12 line cut to length) allow for a dimming power of 3,000 W/VA max at one load line.

Not suitable for dimming fluorescent lamps, transformers with current monitor and high-reactance transformers.

Description/ application	Power loss	Order details	Bbn 4011395	Price 1 piece	Price group	Weight 1 piece	Pack. unit
	W	Type code	Order code	EAN		kg	pc.
high-performance dimmer	6	STD-500 U	GJB0 006 590 A0178	06692 8			1
extension	6	STD-420 E	GJB0 006 590 A0179	06693 5			1
rotary operation element	-	STD-OCD	GJB0 006 590 A0183	06698 0			1
button operation element	-	STD-OCP	GJB0 006 590 A0181	06695 9			1
timer operation element	-	STD-OCT	GJB0 006 590 A0185	07056 7			1

Note: Load and control cables must not be laid in one cable.

Technical features

Rated voltage	230 V ~ ± 10%, 50/60 Hz	
Rated current	STD U	2.17 A
	STD E	1.83 A
Max. connected load	U	500 W/VA
	E	420 W/VA
Power extension	1 U + max. 6 E/phase = > max. 3 kVA	
Min. connected load	STD U	60 W/VA
	STD E	200 W/VA
Max. line length	100 m pushbutton cable, 2 m data line	
Interference suppression	CE	
Ambient temperature	0 to + 45°C, higher temperatures reduce the power	

Electronic protection against short circuit, overload, excessive temperature, automatic load recognition, soft-OFF function optional, memory function, minimum brightness control, visual overload indication

Connected load / ambient temperature diagram

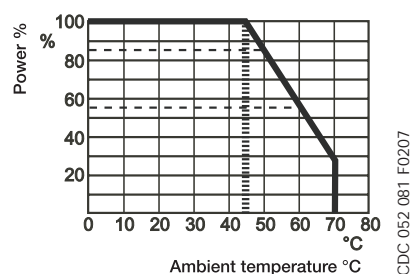

Universal dimmer for phase control and reverse phase control

Plug-in operation elements:
pushbutton operation element (STD-OCP)
rotary operation element (STD-OCD)
timer (STD-OCT)

Application

Remove dimmer cap and snap on operation element to provide for control of dimmer with central pushbutton or rotary operation. Local operation elements are still active.
Apart from the manual local control feature, the timer also allows for time-programmed operations.

Basic timer functions:

- year time switch with 48 time programs
- optional with/without decentralized pushbutton control
- special programs: adjustable background brightness, cycle, display and emergency light, holiday program
- running reserve: 5 hours

7

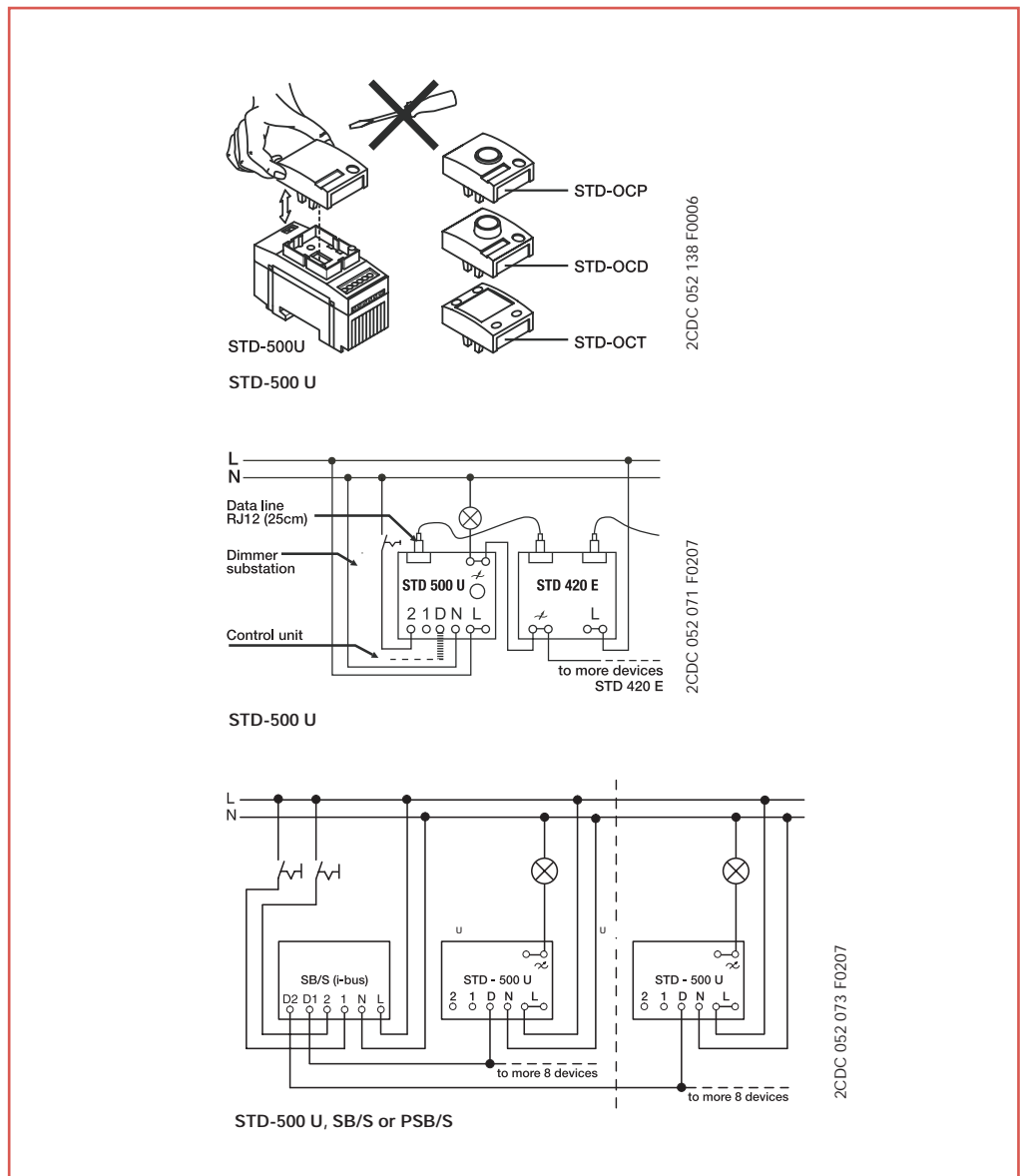



AT electro-mechanical time switches

They control circuit opening and closing according to the scheduled program. Available both on daily and weekly version and equipped with a 16A contact, they can be set on the scheduled program or on the permanent ON function (ON-OFF only for three modules versions). The AT1-R, AT3-R and AT3-7R versions are equipped with a built-in battery, generally charged by the network voltage, which allows the devices to maintain the set time also in case of long (up to 200h) power supply failures. The products fit applications such as shop lighting systems, public buildings, schools, heating and irrigation systems and so forth.

Contacts	Running reserve	Version	Order details	Bbn 8012542	Price 1 piece	Price group	Weight 1 piece	Pack unit
			Type code	Order code	EAN			
						kg	pc.	
1NO	-	daily	AT1	2CSM204205R0601	042051		0,095	1
1NO	200h	daily	AT1-R	2CSM204215R0601	042150		0,095	1
1CO	-	daily	AT3	2CSM204225R0601	042259		0,180	1
1CO	200h	daily	AT3-R	2CSM204235R0601	042358		0,180	1
1CO	200h	weekly	AT3-7R	2CSM204245R0601	042457		0,180	1

Technical features

		AT1	AT1-R	AT3	AT3-R	AT3-7R
Rated supply voltage	[V]	230 a.c. + 10%				
Contact type		1NO	1NO	1CO	1 CO	1CO
Switching capacity						
resistive load	[A]	16				
inductive load	[A]	4	4	3	3	3
Rated frequency	[Hz]	50-60				
Time base		quartz				
Minimum switching time	[min]	15	15	15	15	120
Max number of commands per cycle		96	96	96	96	84
Running reserve	[h]	-	200	-	200	200
Accuracy		+ 1sec / 24h				
Power consumption	[VA]	0,5				
Terminal size for cable	[mm ²]	4				
Terminals		loss-proof screw				
Mounting		on DIN rail				
Operating temperature	[°C]	-10...+55				
Storage temperature	[°C]	-20...+65	-20...+65	-20...+70	-10...+55	-10...+55
Modules		1	1	3	3	3
Reference standards		EN 60730-1 ; EN 60730-2-7				

7

Programming

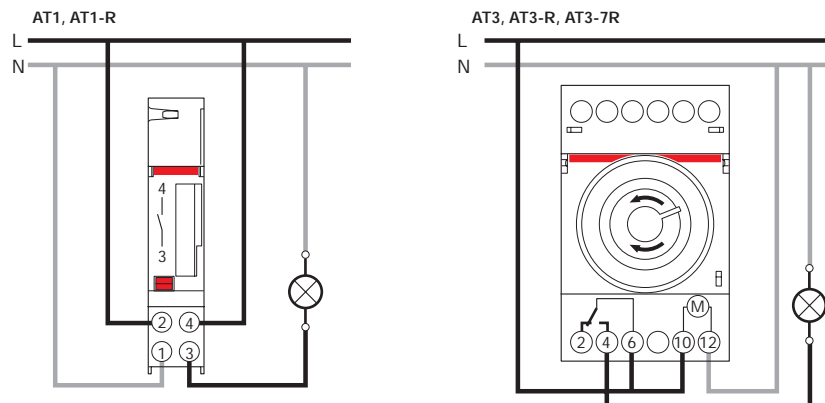

Programming AT1 - AT1-R

Switching dial

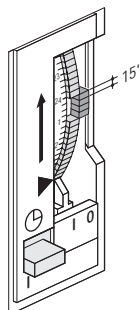

Time setting

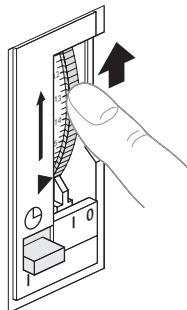

Manual override

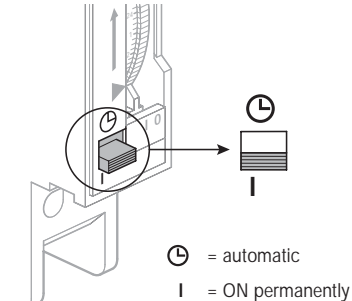

Programming

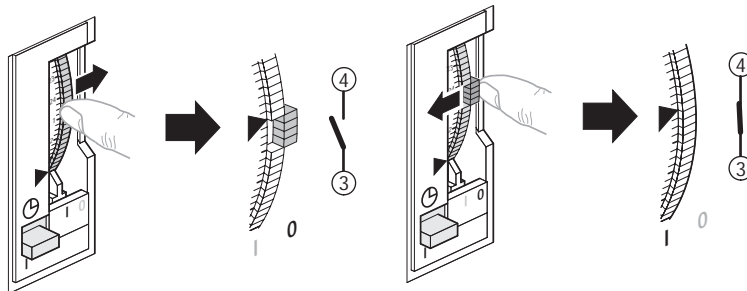

7

Programming AT3 - AT3-R - AT3-7R

Setting the time

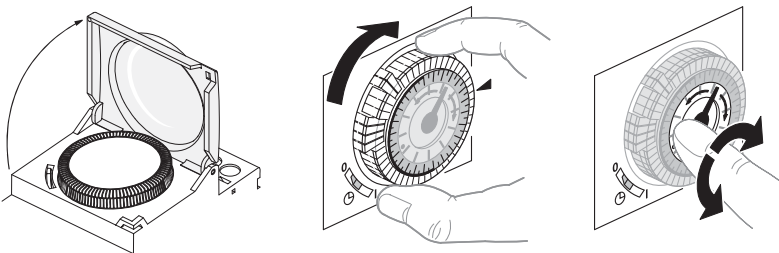

Program setting

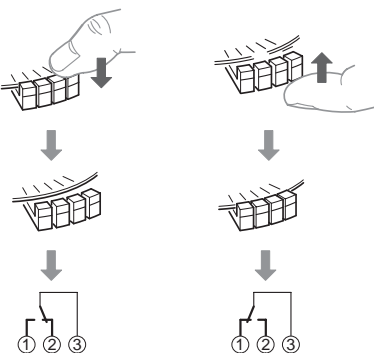

Manual override

3-position selector:

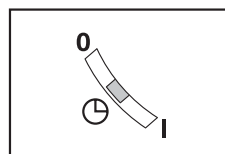

- 0 = permanently OFF
- ⌚ = automatic programmed operation
- I = permanently ON.



AT2 electro-mechanical time switches

The AT2 versions are particularly useful where there is the need to have a complete visibility of the programmable dial in only two modules. They control, as well as the AT1 and AT3 ones, circuit opening and closing according to a scheduled program and are available both on daily and weekly version with a 16A change-over contact. They can be set on the scheduled program or on permanent ON and the versions AT2-R and AT2-7R are equipped with a built-in battery, generally charged by the network voltage, which allows the devices to maintain the set time also in case of long (up to 150h) power supply failures. The products fit applications such as store lighting system, public buildings, schools, heating and irrigation systems and so forth.

Contacts	Running reserve	Version	Order details		Bbn 8012542	Price 1 piece	Price group	Weight 1 piece	Pack unit
			Type code	Order code					
1 CO	-	daily	AT2	2CSM204105R0601	041054			0,118	1
1 CO	150h	daily	AT2-R	2CSM204115R0601	041153			0,118	1
1 CO	150h	weekly	AT2-7R	2CSM204125R0601	041252			0,118	1

Technical features

	AT2	AT2-R	AT2-7R
Rated supply voltage	[V]	230 a.c.	
Contact type		1 CO	
Switching capacity			
resistive load	[A]	16	
inductive load	[A]	4	
Rated frequency	[Hz]	50-60	
Time base		quartz	
Minimum switching time	[min]	30	210
Max number of commands per cycle		48	
Running reserve	[h]	-	150
Accuracy			+ 1sec / 24h
Power consumption	[VA]		0,5
Terminal size for cable	[mm ²]		2,5
Terminals			loss-proof screw
Mounting			on DIN rail
Operating temperature	[°C]		-10 ...+50
Storage temperature	[°C]		-10 ...+50
Modules			2
Reference standards			EN 60730-1 ; EN 60730-2-7

Connection diagram

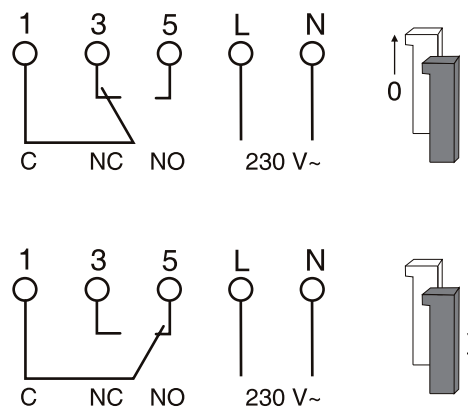

Time setting

AT2 - AT2-R

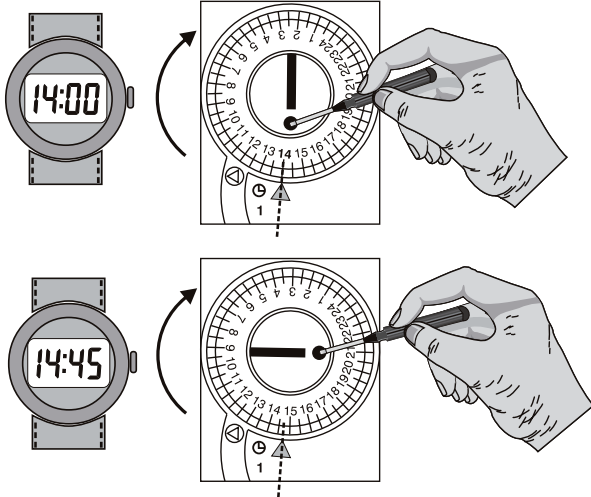

AT2-7R

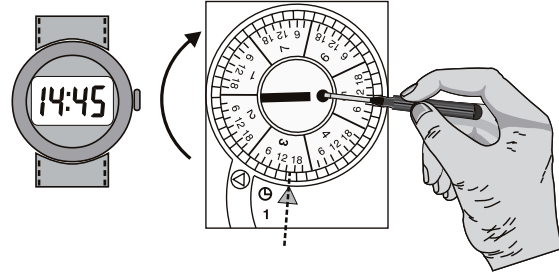

GB Example: 3 = Wednesday 14:45

Programming

Type mode

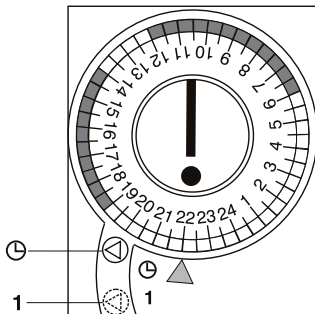

- ⌚ = Working according to the scheduled program
- 1 = Permanent ON

Switching dial

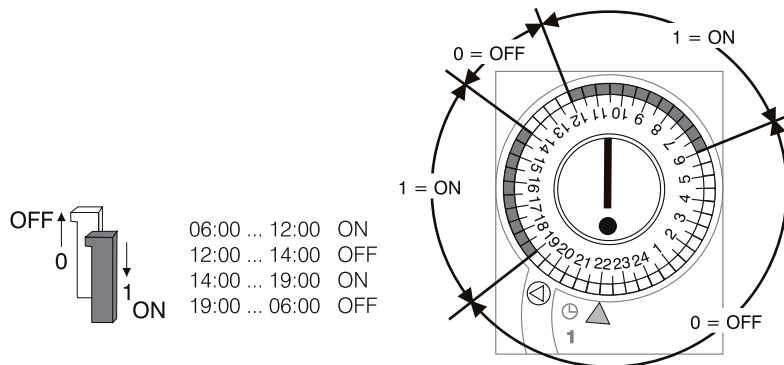

7



DT digital time switches

The digital versions, included in the range, are equipped with a permanent EEPROM memory which allows them to respect the scheduled program and the preservation of the data and hour settings also in the case of long power supply failures. The range, used for both daily and weekly programming, includes single/double channels versions with a change-over contact with a switching capacity of 16(10)A. The programming key, available on versions DT...-K, guarantees an easy and quick programming of n switches avoiding the numbers of mistakes due to future modifications. The DT1-IK/DCF time switch can be combined with the antenna DT-DCF for the automatic synchronization of one or more switches, even if mounted in unsupervised places, with Frankfurt DCF77 official time. The novelties regard the holiday mode that allows to force the ON-OFF output for a certain period, the random mode used to simulate the presence and the waiver one to carry out waivers remotely or locally.

Contacts	Version	Order details	Bbn 8012542	Price 1 piece	Price group	Weight 1 piece	Pack unit
		Type code	Order code	EAN			kg pc.
1CO		DT1	2CSM204255R0611	042556		0,160	1
1CO	key	DT1-K	2CSM204265R0611	042655		0,160	1
1CO	key + pulse	DT1-IK	2CSM204275R0611	042754		0,160	1
1CO	24VAC/DC + key + pulse	DT1-IK/24	2CSM204285R0611	042853		0,160	1
1CO	key + antenna DCF + pulse	DT1-IK/DCF	2CSM204295R0611	042952		0,160	1
2 CO		DT2	2CSM204305R0611	043058		0,160	1
2 CO	key	DT2-K	2CSM204315R0611	043157		0,160	1
2 CO	key + pulse	DT2-IK	2CSM204325R0611	043256		0,160	1

Technical features

		DT1; DT1-K; DT1-IK	DT1-IK/24	DT1-IK/DCF	DT2; DT2-K; DT2-IK
Rated supply voltage	[V]	230 a.c. + 15%	12 a.c./d.c. +20%-10%; 24 a.c./d.c. +10%-15%	230 a.c. + 15%	230 a.c. + 15%
Contact type		1 CO	1 CO	1 CO	2 CO
Switching capacity					
resistive load	[A]		16		
inductive load	[A]		10		
Rated frequency	[Hz]		50-60		
Time base			quartz		
Minimum time between two steps	[min]		1		
Program steps			56		
Power reserve	[years]		5		
Accuracy			+ 1.5 sec / 24h		
Power consumption	[VA]	6	0,8	0,5	6
Terminal size for cable	[mm ²]		4		
Terminals			loss-proof screw		
Mounting			on DIN rail		
Operating temperature	[°C]		-5...+45		
Storage temperature	[°C]		-20...+60		
Modules			2		
Reference standards			EN 60730-1 ; EN 60730-2-7		

Features

	DT1	DT1-K	DT1-IK	DT1-IK/24	DT1-IK/DCF	DT2	DT2-K	DT2-IK
Programming key		■	■	■	■		■	■
Pulse			■	■	■			■
Random mode			■	■	■			■
Holiday mode			■	■	■			■
Walver mode			■					
Radiosynchronized					■			
Backlit display			■					■

Keys

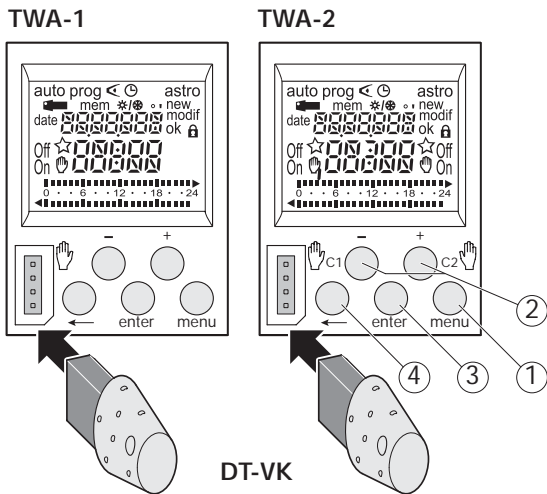

Keys

- ① menu : selection of operating mode.
- auto : mode of running according to the program selected.
- prog : **new** for programming mode.
- prog : **modif** to modify an existing program.
- ◀ : checking of the program.
- ⌚ : modification of time, date and selection of the winter/summer timechange mode ☀/☁
- astro : astronomical mode.
- ☆ : indicates that the channel is in astronomical mode.
- ② + and - : navigation or setting of values.
- (TWA-1)
C1 (TWA-2) : in auto mode, selection of overrides, or waivers.
C2
- ③ enter : to validate flashing information on display.
- ④ ← : to return to the previous step.

7

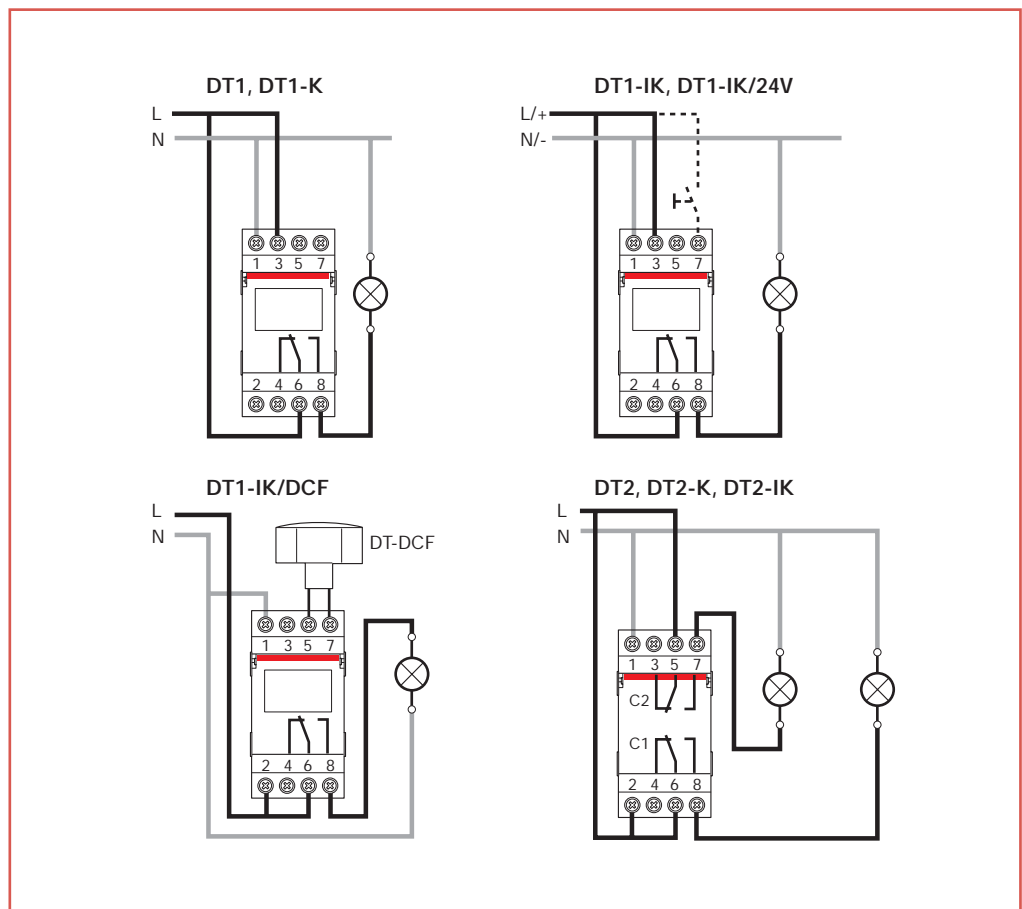



Accessories for DT digital time switches

The whole switching program can be operated directly on your PC using the HANDYTIMER software. The program, once created, can be transferred in the DT-VK key in order to be quickly copied in n digital time switches of the DT...-K range avoiding the errors due to future modifications. The version DT-LK, on the other hand, allows to lock the keyboard to prevent possible manipulations. The DT1-IK/DCF time switch can use the antenna DT-DCF for the automatic synchronization of one or more switches, even if mounted in unsupervised places, with Frankfurt official time signal transmitted via radio on long waves. The capacity of the DCF77 signal is around 2,000 km from Frankfurt.

Version	Order details	Bbn 8012542	Price 1 piece	Price group	Weight 1 piece	Pack unit
	Type code	Order code	EAN		kg	pc.
programming key	DT-VK	2CSM204335R0611	043355		0,005	1
locking key	DT-LK	2CSM204615R0611	046158		0,005	1
software HANDYTIMER and software plug-in adaptor with USB cable	DT-SW	2CSM204345R0611	043454		0,200	1
antenna for DT1-IK/DCF	DT-DCF	2CSM204355R0611	043553		0,150	1

Programming with HANDYTIMER software

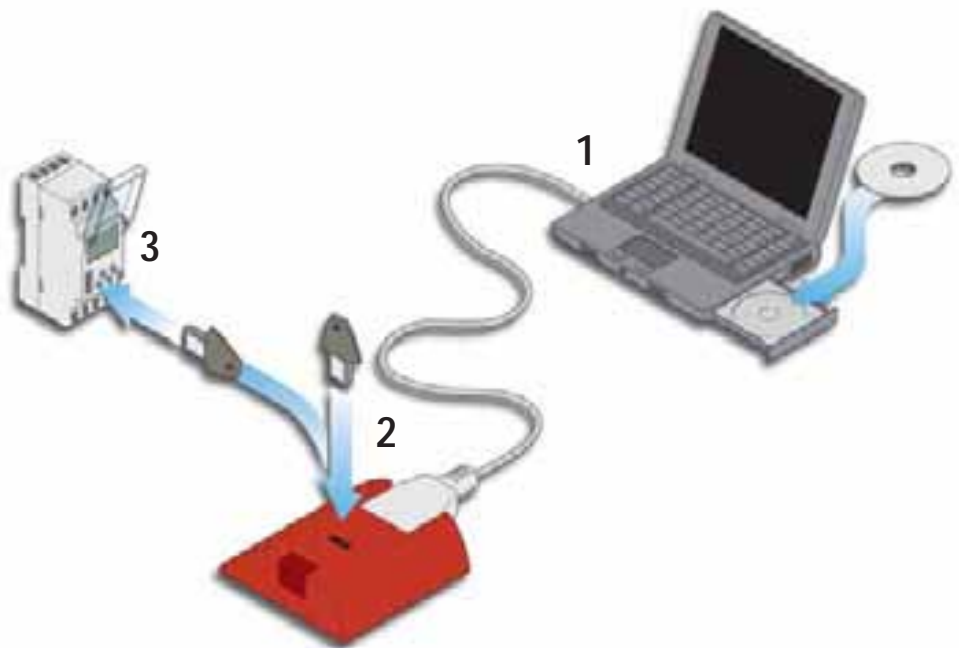

Minimum requirements:

- Microsoft Windows 95 or higher
- 15Mb RAM

- 1a - Plug the interface of the HANDYTIMER-plug adaptor into the USB port of your PC
- 1b - Install the HANDYTIMER software on your PC
- 1c - Define the program
- 2a - Insert the programming key in the HANDYTIMER plug-in adaptor
- 2b - Copy the program in the programming key
- 3 - Insert the programming key in the time switch to transfer the program
- 4 - The programming key can now serve as back-up or for program transfer from time switch to time switch

Connection diagram

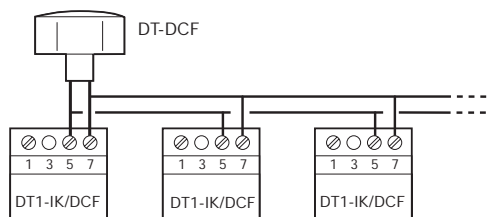

The DT-DCF antenna allows you to control up to 10 instruments. The polarity of the first instrument is regardless, while the others have to respect the polarity of the first one.

Antenna DT-DCF operation field



Mounting

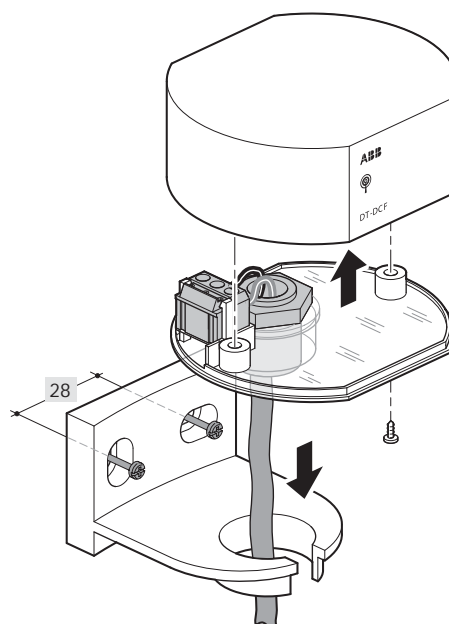



Technical Data overview

Logic relays

- 8 or 12 digital inputs
- 4 or 6 digital relay outputs
- optionally with 4 or 8 transistor outputs
- 128 rungs
- 3 contacts as n/o or n/c contacts in series plus 1 coil per rung
- optionally with 2 or 4 analog inputs (not 100-240 V AC version)
- power flow display for checking the circuit diagram (devices with display)
- expansions for local or remote level
- enclosure color RAL 7035
- DIN rail mounting

Display system

- useable as compact HMI logic relay
- fully graphic, backlit display module
- 12 digital inputs
- 4 digital relay outputs
- optionally with 4 transistor outputs
- 265 rungs
- 4 contacts as n/o or n/c contacts in series plus 1 coil per rung
- optionally with 4 analog inputs (not 100-240 V AC version)
- networking-compatible via CL-NET
- front panel mounting
- expansion for local

Remote display

- Remote display up to a distance of 5 m
- Illustration of text and status displays
- Remote adjustment via keypad
- Front panel mounting

Software

- 16 timing relays 0.01-99:59 h
- 16 counting relays for up-, down counting
- 8 weekly timer, 8 annual timers
- 16 analog value comparators
- 16 freely editable text display
- 32 markers or auxilliary relays

Concept

CL range logic relays are suitable for small and medium-sized control tasks and are able to substitute logic wiring in a quick and simple manner.

They can be used for applications in control as well as for timing functions, e. g.

- in buildings, lighting systems, air-conditioning systems, general control functions,
- in small machines and systems or
- as stand-alone control module for small applications.

Steps to the application of CL range

- CL range can be used easily, rapidly and comfortably without any time-consuming planning and programming.
- The user can discover the advantages and the benefit of these logic relays in no time at all.
- CL range provides for the control statements according to a simple circuit diagram.
- Setup, storage, simulation and documentation are performed using the compact and user-friendly CL-SOFT software (CL-LAS.PS002).

Software characteristics (CL-SOFT)

- display on a PC monitor according to IEC, ANSI
- up to 10 languages to choose from
- easy installation on all Microsoft Windows™ operating systems

Logic links instead of wiring

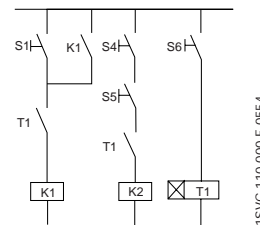

Further Documentation

(download from the internet:
www.abb.com/lowvoltage

- Control Products
- Electronic Relays and Controls)

Technical catalogue

Electronic Products
and Relays 2CDC 110 004 C0205

Manuals

Logic relay manual 1SVC 440 795 M0100
Remote display manual 1SVC 440 795 M2100
Display system manual 1SVC 440 795 M1100

System overview

Logic relays

2CDC 312 036 F0b07

- 1a Logic relay CL-LS..
- 1b Logic relay CL-LM..
- 2 Power supply CL-LAS.SD00...
- 3 I/O expansion CL-LER., CL-LET.. for logic relays CL-LM..
- 4 Coupler unit CL-LEC.. for remote expansion of logic relays CL-LM..
- 5 Memory module CL-LAS.MD003 for logic relays CL-LS., CL-LM..
- 6 Connecting cable CL-LAS.TK001, CL-LAS.TK002 to connect PC
- 7 CL-LINK plug CL-LAS.TK011 to connect expansion to logic relays CL-LM..
- 8a Remote display connection module CL-LDC.S..
- 8b Connecting cable CL-LAD.TK007 to connect a remote displays to a logic relay
- 9 Display module CL-LDD..

Display system □ Compact HMI logic relay

2CDC 312 025 F0b06

- 1 Display module CL-LDD..
- 2 Display base module CL-LDC.LN..
- 3 Display I/O module CL-LDR., CL-LDT..
- 4 Termination resistor CL-LAD.TK009
- 5 I/O expansion CL-LER., CL-LET..
- 6 Coupler unit CL-LEC.. for remote expansion
- 7 Memory module CL-LAD.MD004 for display base module
- 8 Connecting cable CL-LAD.TK002, CL-LAD.TK003, CL-LAD.TK004
- 9 Connecting cable CL-LAD.TK001, CL-LAD.TK011 to connect PC
- 10 CL-LINK plug CL-LAS.TK011 for expansion of logic relays CL-LM..

■ e.g. door of switchgear cabinet

Stand alone with I/O module

2CDC 312 027 F0b06

- 1 Display CL-LDD..
- 2 Remote display connection module CL-LDC.S.. incl. connecting cable
- 3 Display base module CL-LDC.LN..

Expansion of logic relays

2CDC 312 037 F0b07

- 1 Logic relay CL-LM..
- 2 I/O expansion CL-LER., CL-LET..
- 2a local expansion
- 2b remote expansion
- 3 Coupler unit CL-LEC.. for remote expansion of logic relays CL-LM..
- 4 CL-LINK plug CL-LAS.TK011 for expansion of logic relays CL-LM.. up to 30 m

Communication via CL-NET

2CDC 312 026 F0b06

- 1 Display CL-LDD..
- 2 Display base module CL-LDC.LN.. for CL-NET
- 3 Display I/O module CL-LDR., CL-LDT..
- 4 Connecting cable CL-LAD.TK002, CL-LAD.TK003, CL-LAD.TK004
- 5 Termination resistor CL-LAD.TK009

2CDC 311 034 F0606



CL-LSR

2CDC 311 033 F0606



CL-LST

2CDC 311 036 F0606



CL-LMR

2CDC 311 035 F0606



CL-LMT

2CDC 311 037 F0606



CL-LER

2CDC 311 038 F0606



CL-LEC

Type	Rated operational voltage	Display + Keypad	Timer	Expandable	Order code	Pack. unit pieces	Price 1 piece	Weight 1 piece kg/lb
------	---------------------------	------------------	-------	------------	------------	-------------------	---------------	----------------------

Logic relays – 8 inputs, 4 relay outputs

CL-LSR.C12AC1	24 V AC	•	•		1SVR 440 712 R0300	1		0.20/0.44
CL-LSR.CX12AC1	24 V AC			•	1SVR 440 712 R0200	1		0.20/0.44
CL-LSR.12AC2	100-240 V AC	•			1SVR 440 713 R0100	1		0.20/0.44
CL-LSR.C12AC2	100-240 V AC	•	•		1SVR 440 713 R0300	1		0.20/0.44
CL-LSR.CX12AC2	100-240 V AC			•	1SVR 440 713 R0200	1		0.20/0.44
CL-LSR.C12DC1	12 V DC	•	•		1SVR 440 710 R0300	1		0.20/0.44
CL-LSR.CX12DC1	12 V DC			•	1SVR 440 710 R0200	1		0.20/0.44
CL-LSR.12DC2	24 V DC	•			1SVR 440 711 R0100	1		0.20/0.44
CL-LSR.C12DC2	24 V DC	•	•		1SVR 440 711 R0300	1		0.20/0.44
CL-LSR.CX12DC2	24 V DC			•	1SVR 440 711 R0200	1		0.20/0.44

Logic relays – 8 inputs, 4 transistor outputs

CL-LST.C12DC2	24 V DC	•	•		1SVR 440 711 R1300	1		0.20/0.44
CL-LST.CX12DC2	24 V DC			•	1SVR 440 711 R1200	1		0.20/0.44

Logic relays – 12 inputs, 6 relay outputs

CL-LMR.C18AC1	24 V AC	•	•	•	1SVR 440 722 R0300	1		0.36/0.79
CL-LMR.CX18AC1	24 V AC			•	1SVR 440 722 R0200	1		0.36/0.79
CL-LMR.C18AC2	100-240 V AC	•	•	•	1SVR 440 723 R0300	1		0.36/0.79
CL-LMR.CX18AC2	100-240 V AC			•	1SVR 440 723 R0200	1		0.36/0.79
CL-LMR.C18DC1	12 V DC	•	•	•	1SVR 440 720 R0300	1		0.36/0.79
CL-LMR.CX18DC1	12 V DC			•	1SVR 440 720 R0200	1		0.36/0.79
CL-LMR.C18DC2	24 V DC	•	•	•	1SVR 440 721 R0300	1		0.36/0.79
CL-LMR.CX18DC2	24 V DC			•	1SVR 440 721 R0200	1		0.36/0.79

Logic relays – 12 inputs, 8 transistor outputs

CL-LMT.C20DC2	24 V DC	•	•	•	1SVR 440 721 R1300	1		0.36/0.79
CL-LMT.CX20DC2	24 V DC			•	1SVR 440 721 R1200	1		0.36/0.79

Type	Rated operational voltage	Order code	Pack. unit pieces	Price 1 piece	Weight 1 piece kg/lb
------	---------------------------	------------	-------------------	---------------	----------------------

Expansion – 2 relays outputs

CL-LER.20	-	1SVR 440 709 R5000	1		0.07/0.15
-----------	---	--------------------	---	--	-----------

Expansions – 12 inputs, 6 relay outputs

CL-LER.18AC2	100-240 V AC	1SVR 440 723 R0000	1		0.26/0.57
CL-LER.18DC2	24 V DC	1SVR 440 721 R0000	1		0.22/0.49

Expansion - 12 inputs, 8 transistor outputs

CL-LET.20DC2	24 V DC	1SVR 440 721 R1000	1		0.21/0.46
--------------	---------	--------------------	---	--	-----------

Coupler unit for remote expansion with a distance of up to 30 m

CL-LEC.CI000	-	1SVR 440 709 R0000	1		0.07/0.15
--------------	---	--------------------	---	--	-----------

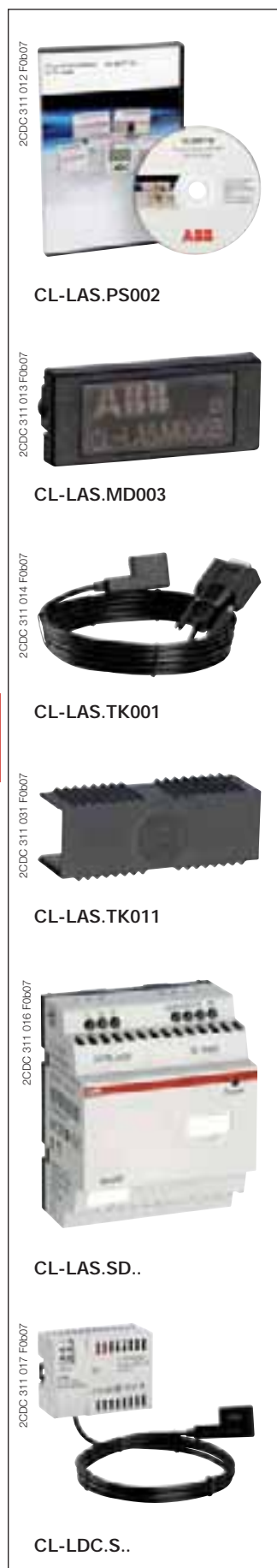

CL-LAS.PS002

CL-LAS.MD003

CL-LAS.TK001

CL-LAS.TK011

CL-LAS.SD..

CL-LDC.S..

Type	Description	Order code	Pack. unit pieces	Price 1 piece	Weight 1 piece kg/lb
Software CL-SOFT for programming and control of CL range devices					
CL-LAS.PS002	Installation CD-ROM for Microsoft Windows™	1SVR 440 799 R8000	1		0.10/0.21
Memory module for logic relays					
CL-LAS.MD003	Memory size: 32 kB	1SVR 440 799 R7000	1		0.02/0.04
Connecting cable with serial interface to connect PC and logic relay					
CL-LAS.TK001	Length: 2 m	1SVR 440 799 R6000	1		0.10/0.22
Connecting cable with USB interface to connect PC and logic relay					
CL-LAS.TK002	Length:	1SVR 440 799 R6100	1		
Connecting cable for point-to-point connection of remote-display connection module and logic relay					
CL-LAD.TK007	Length: 5 m, adaptable	1SVR 440 899 R6600	1		0.20/0.44
Fixing brackets for screw mounting of logic relay, expansion, display base module					
CL-LAS.FD001	content: 9 fixing brackets	1SVR 440 799 R5000	1		0.01/0.01
Connecting plug CL-LINK for connection of logic relay to expansion					
CL-LAS.TK011	CL-LINK	1SVR 440 799 R5100	1		0.10/0.22
Input-/ output simulator with wall power supply, fits to CL-LSR and CL-LST					
CL-LAS.TD001	100-240 V AC 24 V DC	1SVR 440 793 R0000	1		0.19/0.43
Primary switch mode power supplies					
CL-LAS.SD001	100-240 V AC 24 V DC / 0.35 A 12 V DC / 20 mA	1SVR 440 703 R0000	1		0.10/0.22
CL-LAS.SD002	100-240 V AC 24 V DC / 1.25 A	1SVR 440 713 R0000	1		0.20/0.44
Graphic display modules 132 x 64 pixel					
CL-LDD.XK	without keyboard	1SVR 440 839 R4500	1		0.14/0.30
CL-LDD.K	with keyboard	1SVR 440 839 R4400	1		0.13/0.29
Remote display connection modules to displace the display from the logic relay, incl. connecting cable CL-LAD.TK007, 5 m, length adaptable					
CL-LDC.SDC2	24 V DC	1SVR 440 841 R0000	1		0.16/0.36
CL-LDC.SAC2	100-240 V AC	1SVR 440 843 R0000	1		0.16/0.36



Type	Rated operational voltage	Order code	Pack. unit pieces	Price 1 piece	Weight 1 piece kg/lb
Graphic Display modules 132 x 64 pixel					
CL-LDD.XK	without keyboard	1SVR 440 839 R4500	1		0.14/0.30
CL-LDD.K	with keyboard	1SVR 440 839 R4400	1		0.13/0.29
Display base modules - CPU / power supply					
CL-LDC.LDC2	24 V DC	1SVR 440 821 R0000	1		0.16/0.36
CL-LDC.LAC2	100-240 V AC	1SVR 440 823 R0000	1		0.16/0.36
Display base modules - CPU / power supply, networking-compatible (CL-NET)					
CL-LDC.LNDC2	24 V DC	1SVR 440 821 R1000	1		0.17/0.38
CL-LDC.LNAC2	100-240 V AC	1SVR 440 823 R1000	1		0.17/0.38
Display I/O modules - 8 inputs, 4 relay outputs					
CL-LDR.16AC2	100-240 V AC	1SVR 440 853 R0000	1		0.17/0.38
CL-LDR.16DC2	24 V DC	1SVR 440 851 R0000	1		0.17/0.38
Display I/O modules - 8 inputs, 4 relay outputs, 1 analog output					
CL-LDR.17DC2	24 V DC	1SVR 440 851 R2000	1		0.17/0.38
Display I/O module - 8 inputs, 4 transistor outputs					
CL-LDT.16DC2	24 V DC	1SVR 440 851 R1000	1		0.14/0.30
Display I/O module - 8 inputs, 4 transistor outputs, 1 analog output					
CL-LDT.17DC2	24 V DC	1SVR 440 851 R3000	1		0.14/0.30

2CDC 311 01B F0607



CL-LAD.MD004

2CDC 311 021 F0607



CL-LAD.TK009

Type	Description	Order code	Pack. unit pieces	Price 1 piece	Weight 1 piece kg/lb
Memory module for display base modules					
CL-LAD.MD004	Memory size: 256 kB	1SVR 440 899 R7000	1		0.02/0.03
Connecting cable with serial interface to connect PC and display base module					
CL-LAD.TK001	Length: 2 m	1SVR 440 899 R6000	1		0.11/0.23
Connecting cable with USB interface to connect PC and display base module					
CL-LAD.TK011	Length:	1SVR 440 899 R6700	1		
Network cable (CL-NET) to connect 2 display base modules					
CL-LAD.TK002	Length: 0.3 m	1SVR 440 899 R6100	1		0.05/0.12
CL-LAD.TK003	Length: 0.8 m	1SVR 440 899 R6200	1		0.07/0.14
CL-LAD.TK004	Length: 1.5 m	1SVR 440 899 R6300	1		0.08/0.18
Connecting cable for point-to-point connection of remote display connection modules and display base module					
CL-LAD.TK005	Length: 5 m, adaptable	1SVR 440 899 R6400	1		0.20/0.44
Connecting cable for point-to-point connection of 2 display base modules, length adaptable					
CL-LAD.TK006	Length: 5 m	1SVR 440 899 R6500	1		0.12/0.26
Termination resistor					
CL-LAD.TK009	content: 2 pieces	1SVR 440 899 R6900	1		0.01/0.02
Protective covers, transparent					
CL-LAD.FD001	for harsh environmental conditions and application in the food industry	1SVR 440 899 R1000	1		0.03/0.07
CL-LAD.FD011	sealable	1SVR 440 899 R2000	1		0.03/0.07
Assembly tool for mounting of display modules					
CL-LAD.FD002	-	1SVR 440 899 R3000	1		

Index

Selection tables

E 450 priority switches.....	8/2
TW twilight switches	8/3
RAL overload alarms.....	8/8
LSS1/2 load shedding switch	8/10
SQZ3 phase and sequence relay	8/11
LEE 230 power failure signalling extractable lamp	8/12
Max./min. current/voltage ammetric and voltmetric relays.....	8/13
E 235 mains disconnection relays	8/14
E 236 undervoltage monitoring relays	8/15



E 450 priority switches

The priority switch is used in wiring systems where existing lead cross sections or the size of the power supply service box do not allow for simultaneous operation of two powerful loads (e.g. storage heating and flow-type heater).

The priority switch disconnects the long-term load (storage heating) for as long as the short-term consumer (flow-type heater) is switched on.

The coil of the priority switch is connected in series to the short-term load. When this load is switched on, the NC contact of the priority switch disconnects e.g. the heating system contactor.

Rated current range	Power loss	Order details	Bbn	Price	Price group	Weight	Pack unit
	W	Type code	Order code	EAN		kg	pc.

For pneumatically controlled flow-type heaters

6.7 ... 39 A	2.4	E 451- 5.7 A	2CDE160000R0901	41590 3		0.1	10
--------------	-----	--------------	-----------------	---------	--	-----	----

For electronically controlled flow-type heaters

6.7 ... 39 A	2.4	E 452-5.7 A	2CDE160010R0901	20950 2		0.1	10
--------------	-----	-------------	-----------------	---------	--	-----	----

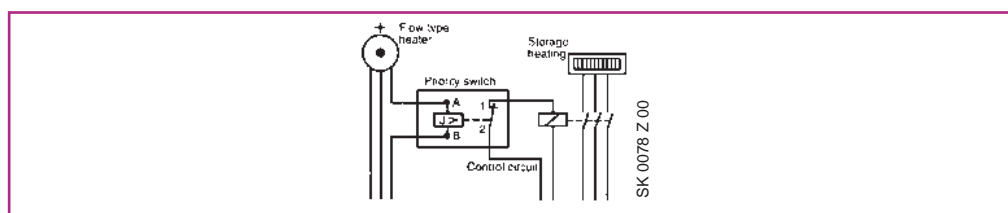

Technical features

E 451-5.7

E 452-5.7

Operating coil

Range of rated current equivalent to	6.7 ... 39 A
Threshold current	1.5 ... 9 kW at 230 V, 4.6 ... 27 kW at 230/400 V
OFF delay (max.)	3.1 ... 5.3 A
Max. continuous current	0 main half waves
Therm. continuous capacity at 40 °C/104 °F	2 main half waves
	43 A
	5 W

Contact assembly

Control contact	1 NC contact
Rated contact current at 250 V	1 A
Contact material	solid silver
Max. switching voltage	400 V
Max. switching capacity	230 VA
Max. switched current	1 A
Max. inrush current peak	5 A
Electr. service life	> 10 ⁵ operations
Mechanical service life	ca. 2 x 10 ⁶ operations
Max. electrical switching rate	ca. 1800 operations/hour
ON duration	100 %
Ambient temperature	- 20 °C/- 4 °F to + 40 °C/104 °F
Response time	10 ... 20 ms
Release time	5 ... 20 ms
Test voltage contact/coil	≥ 20 ms
Clearance and creepage distance	2.5 kV
Degree of protection	C/250 V AC cording to IEC 669-1-23
Protection against electric shock	IP 40
Terminal contact	according to DIN VDE 0106 Part 100 (BGV A2)
	series coil up to 16 mm ² , control contact up to 2.5 mm ²



TW modular twilight switches

They allow to switch on and switch off lighting devices according to a scheduled level of the ambient light. They are used in combination with a sensor to detect if the ambient light is higher or lower than the set level. TW2/10K, equipped with three different types of adjustment range (2:100, 2:1,000, 2:10,000), fits well the daylight applications where the Lux value is very high. The version TW1-D, with built-in time switch, allows the control of the lighting system in relation to the set level of the ambient light combined with a specific time planning. This range, thanks to its features, fits all the applications (for example shop windows and lights) where the rationalization of the energy consumption is required.

Brightness range	Order details	Bbn 8012542	Price 1 piece	Price group	Weight 1 piece	Pack unit
lx	Type code	Order code	EAN		kg	pc.
2 : 100	TW1	2CSM204135R1341	041351		0.107	1
2 : 10.000	TW2/10K	2CSM204145R1341	041450		0.215	1
2 : 200	TW1/D*	2CSM204155R1341	041559		0.112	1

* Digital timer integrated

Accessories for TW modular twilight switches

The photosensor is supplied in the same package of the switch, but it's also available separately as spare part. The upper part of the external case (with screw locking), made up of thermoplastic material, bears up against ultraviolet rays to guarantee an homogeneous diffusion of the daylight internally. The photosensor, wall mounted, is supplied with a cable gland.

Order details	Bbn 8012542	Price 1 piece	Price group	Weight 1 piece	Pack unit
Type code	Order code	EAN		kg	pc.
LS-SP	2CSM204195R1341	041955		0.035	1

Connection diagram

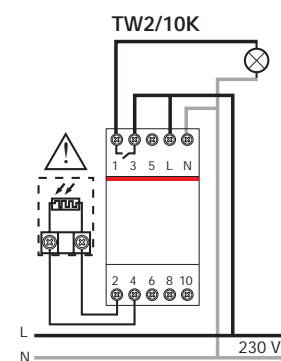
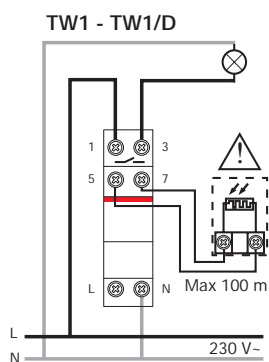

Technical features

	TW1	TW/10K	TW1-D
Rated supply voltage	[V]	230 a.c.	
Contact type	1NO	1CO	1NO
Switching capacity			
resistive load	[A]	16	
inductive load cosφ 0,6	[A]	3	
incandescent lamps	cosφ 1	max 960W	max 1080W
fluorescent lamps	cosφ 0,8	max 720W	max 720W
fluorescent - duo./electronic lamps	cosφ 0,9	max 2000W	max 2000W
Rated frequency	[Hz]	50-60	
Programs ON-OFF	-	-	1 for OFF
Switching delay			
ON	[s]	8 + 10%	8 + 10%
OFF	[s]	38 + 10%	38 + 10%
Brightness range	[lx]		
		2:100	2:200
		2:1,000	
		2:10,000	
Accuracy	-	-	+ 2 sec/day
Protection degree			
twilight switch		IP20	
sensor		IP65	
Operating temperature			
twilight switch	[°C]	0...+55	0...+55
sensor	[°C]	-30...+65	0...+50
Power consumption	[VA]	4,5	3
Terminal size for cable	[mm²]		2,5
Terminals		loss-proof screw	
Mounting		on DIN rail	
Switching status indication/ brightness range		red Led / green Led	LCD display
Max wiring length	[m]	100	
Modules		1	2
Reference standards		EN 60669-1 ; EN 60669-2-1	



TWP pole mounting twilight switch

The TWP pole twilight switch, equipped internally with a preset sensor of 10 Lux, is the ideal solution for the management of external light systems such as the public ones. The sensor is extractable from the base and allows an easy and efficient maintenance without needing further wiring.

Brightness range	Order details	Bbn 4016779	Price 1 piece	Price group	Weight 1 piece	Pack unit
lx	Type code	Order code	EAN		kg	pc.
2 : 200	TWP	2CSM204165R1341	041658		0,155	1

Accessory for TWP pole mounting twilight switch

The LS-65 sensor, supplied also individually as spare part, is equipped with internal connections Fast-On which are fast to extract. The sensor, with the upper part of the external case made up of thermoplastic material, bears up against ultraviolet rays to guarantee an homogeneous diffusion of the daylight internally.

	LS-65	2CSM204185R1341	041856		0,085	1
--	-------	-----------------	--------	--	-------	---

Technical features

		TWP
Rated supply voltage	[V]	230 c.a.
Contact type		1NO polarized
Switching capacity		
resistive load	[A]	16
inductive load cosφ 0,6	[A]	3
incandescent lamps	cosφ 1	max 960W
fluorescent lamps	cosφ 0,8	max 720W
fluorescent - duo./electronic lamps	cosφ 0,9	max 200W
Rated frequency	[Hz]	50-60
Switching delay		
ON	[s]	25 + 10%
OFF	[s]	25 + 10%
Brightness range	[lx]	2:200
Protection degree		IP65
Operating temperature	[°C]	-30...+50
Storage temperature	[°C]	-30...+60
Power consumption	[VA]	7,5
Terminal size for cable	[mm²]	2,5
Terminals		screw
Mounting		pole
Switching status indication/ brightness range		- / red Led
Reference standards		EN 60669-1 ; EN 60669-2-1
Power consumption	[VA]	4,5
Terminal size for cable	[mm²]	2,5
Terminals		loss-proof screw
Mounting		on DIN rail
Switching status indication/ brightness range		red Led / green Led
Max wiring length	[m]	100
Modules		1
Reference standards		EN 60669-1 ; EN 60669-2-1

Connection diagram

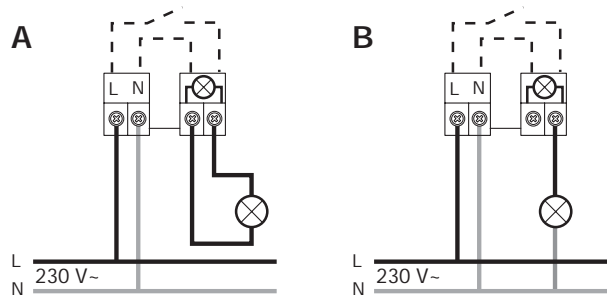

Setting position

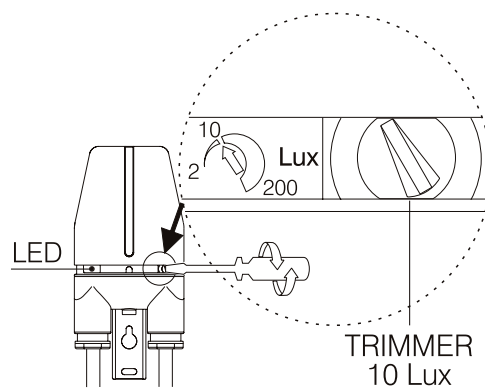

Mounting

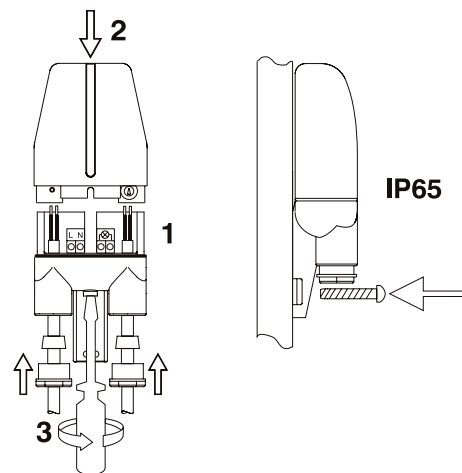



TWA twilight astronomical switches

They allow to control automatically the light systems according to the hour when the sun rises and sets. The programming is made defining the longitude and latitude parameters of the geographical area where the switch is mounted. Thanks to its features the TWA fits applications such as public lighting system, shop windows, monuments, signs and so forth and particularly when the external sensor is subjected to strong external inconveniences like in area with high level of pollution or in area exposed to vandalic acts.

Contacts	Order details	Bbn	Price	Price	Weight	Pack
	Type code	Order code	8012542	1 piece	1 piece	unit
			EAN	group	kg	pc.
1 CO	TWA-1	2CSM204365R1341	043652		0,160	1
2 CO	TWA-2	2CSM204375R1341	043751		0,160	1

Technical features

		TWA-1	TWA-2
Rated supply voltage	[V]	230 a.c.+ 15%	
Contact type		1CO	2 CO
Switching capacity			
resistive load	[A]	16	
inductive load cosφ 0,6	[A]	10	
Rated frequency	[Hz]	50-60	
Time base		quartz	
Minimum time between two steps	[min]	1	
Program steps		56	
Power reserve	[years]	5	
Accuracy		+ 1,5sec / 24h	
Astronomical time accuracy	[min]	+ 10	
Power consumption	[VA]	6	
Terminal size for cable	[mm ²]	4	
Terminals		loss-proof screw	
Mounting		on DIN rail	
Operating temperature	[°C]	-10...+55	
Storage temperature	[°C]	-20...+60	
Protection degree		IP20	
Modules		2	
Reference standards		NFC 15 100 ; IEC 60 634-1	

Connection diagram

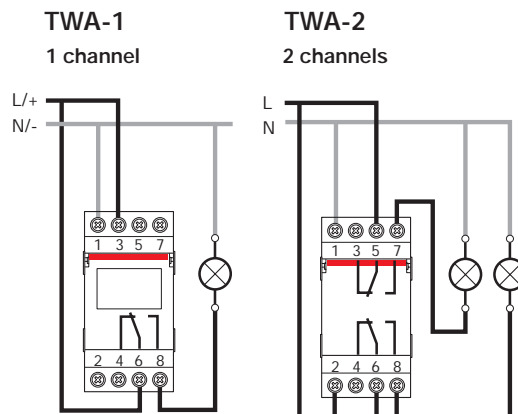

System Selection tables

pro M compact® Load management devices

TWA twilight switches

TWA

Keys

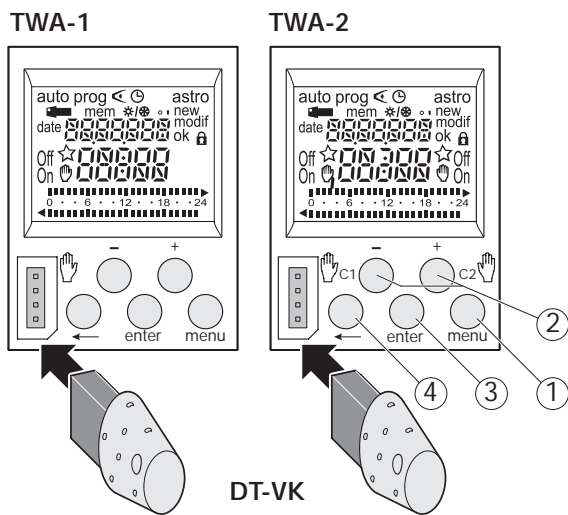

Keys

- ① menu : selection of operating mode.
- auto : mode of running according to the program selected.
- prog : new for programming mode.
- ◀ : modify to modify an existing program.
- ⏪ : checking of the program.
- ⌚ : modification of time, date and selection of the winter/summer timechange mode ⚙️/🌞
- astro : astronomical mode.
- ☆ : indicates that the channel is in astronomical mode.
- ② + and - : navigation or setting of values.
(TWA-1)
- C1 ⤴, C2 ⤴ (TWA-2) : in auto mode, selection of overrides, or waivers.
- ③ enter : to validate flashing information on display.
- ④ ← : to return to the previous step.

Programming example

Ex: Rome

- Ⓛ Longitude 12° EAST
- Ⓛ Latitude 41° NORTH
- Ⓛ +1 Universal Date Time = +1 hour

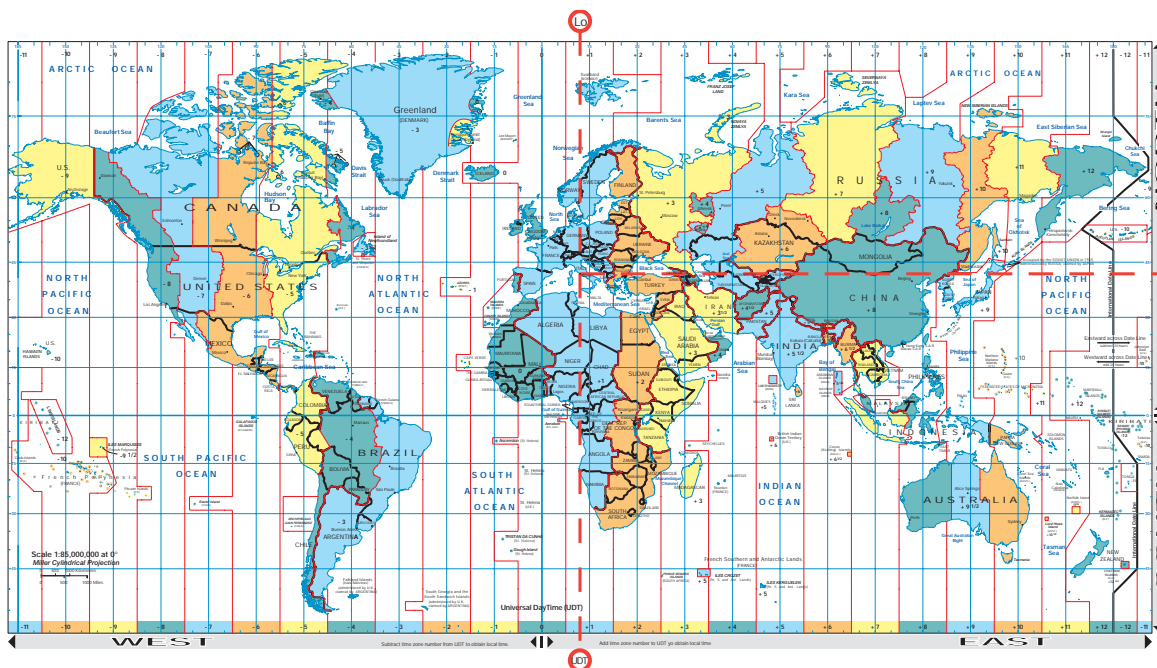
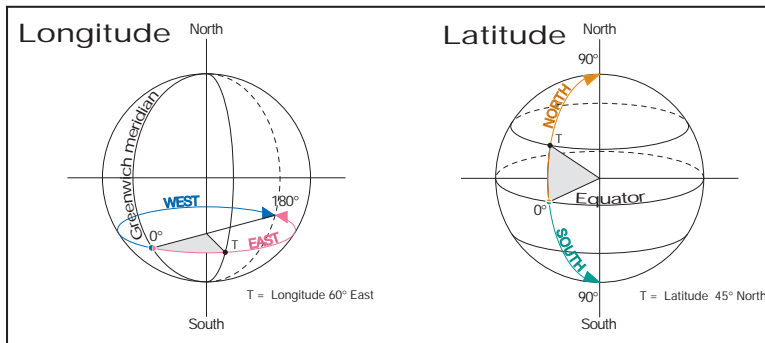

8



RAL overload alarms

Main circuit-breaker downstream installed, they constantly compare preset power consumption value to effective system power consumption, which is related to the number of devices operating simultaneously. An acoustic alarm alerts that it is necessary to switch-off some appliances in order to avoid the tripping of the main circuit-breaker. The device calibration is 3 kW.

Adjustable range	Order details		Bbn	Price	Price	Weight	Pack
kW	Type code	Order code	8012542	1 piece	group	1 piece	unit
			EAN			kg	pc.
0/3	RAL 3	2CSM111200R1301	400509			0.200	1
0/6	RAL 6	2CSM121200R1301	400608			0.200	1

Technical features

Rated voltage U_n	[V]	a.c. 230
Rated current I_n	[A]	18.3 (for 3 kW); 27.5 (for 6 kW)
Rated contact capacity I_n	[A]	12 $\cos\phi=1$; 4 $\cos\phi=0.8$
Rated frequency	[Hz]	50
Adjustment ranges	[A]	0 ...18.3/0...27.5
Power consumption	[W]	10
Modules	[n°]	2
Intervention delay		instantaneous

Additional technical features

RAL overload alarms are equipped with an acoustic alarm which signals an exceeding power consumption, allowing the user to disconnect loads before the energy counter trips.

An appropriate relay output contact allows the choice between the following functions:

- a) remote signalling (acoustic or lighting)
- b) opening a specific divisional circuit-breaker and then disabling a particular not primary electric appliance.

If appropriately used, the function b) causes the automatic switchoff of one or more appliances in order to keep the power consumption within the preset limits, avoiding the unexpected tripping of current-limiting device installed outside the housing (i.e. in the basement). Reset manually.

Acoustic alarm

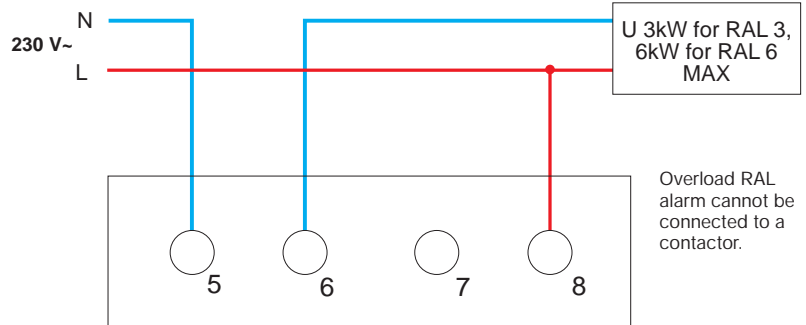

0EPM0051

Load release

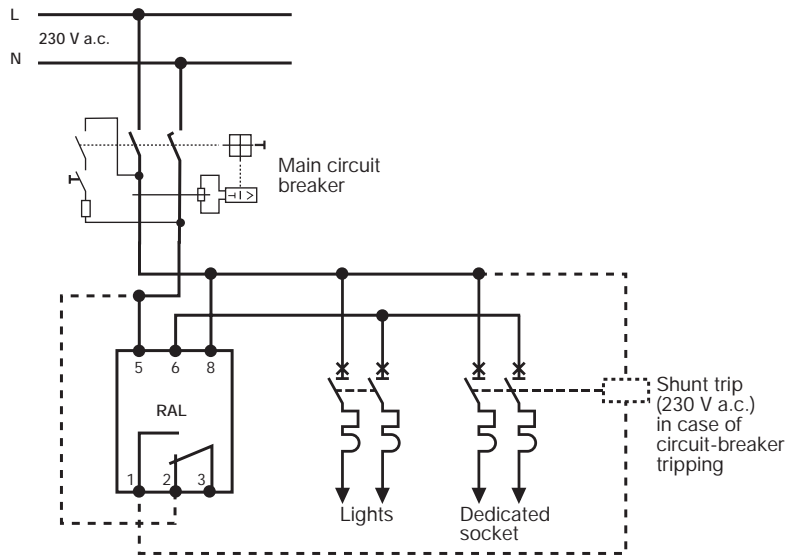

0EPM0052



LSS1/2 load shedding switch

Main circuit-breaker downstream installed, it compares the higher allowed and preset value of power consumption to the effective system power consumption avoiding the tripping of the main circuit-breaker through switching-off in sequence of maximum two not primary loads (NPL1 and NPL2) when the preset threshold is exceeded. A green LED signals the voltage and two red leds indicate load OFF. At preset time intervals the device automatically tries to insert again not primary disabled loads.

Order details	Bbn	Price	Price group	Weight	Pack unit
Type code	Order code	8012542	1 piece	1 piece	
LSS1/2	2CSM112500R1311	EAN		kg	pc.
		274407		0.400	1

Single-phase wiring diagram

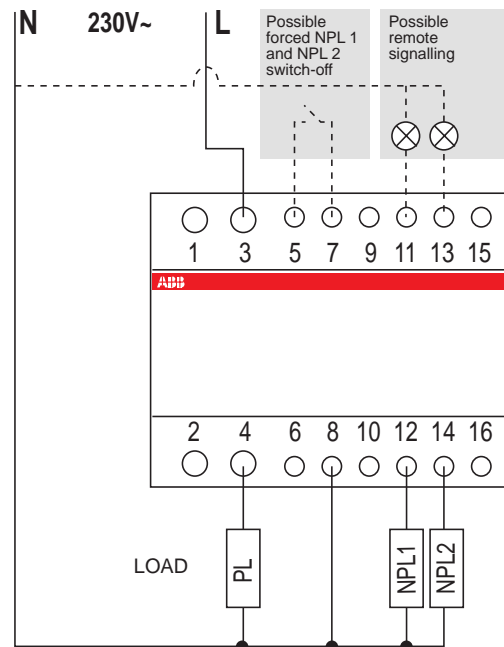

- The device must be main circuit breaker downstream inserted into the network
- PL = Primary Load
- NPL = Not Primary Load

OEPW0150

Technical features

Rated voltage U_n	[V]	a.c. 230
Rated capacity I_n	[A]	90
Rated contact capacity I_n NPL1 and NPL2	[A]	16 each (terminals 12 and 14)
Rated frequency	[Hz]	50/60
Regulating thresholds	[A]	5...30 10...60 15...90
Load reinsertion delay		5-7 min. (NPL1); 4-5, 50 min. (NPL2)
Load disinsertion delay		about 2 sec.
Indicators		1 green LED= supply voltage available 2 red LED= switched off loads
Load OFF remote signalling	[A]	1 (terminals 11 and 13)
Terminals	Primary load	35 mm ²
	Not primary loads	10 mm ²
Power consumption	[W]	5
Modules	[n°]	5

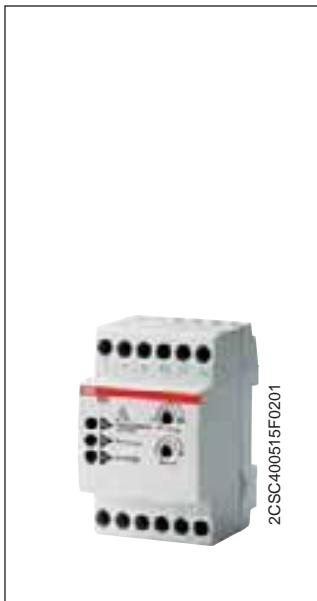

SQZ3 phase and sequence relay

SQZ3 relay performs the following continue monitoring functions on three-phase networks at 400 V a.c.:

- phase sequence
- phase failure
- minimum voltage (adjustable up to 70% of Vn).

If one of the three failures is detected, the output relay (safety switching contact) intervenes with a delay adjustable from 2 to 20 seconds for minimum voltage only and controls the following:

- acoustic alarms
- motor controlling contactors
- circuit-breakers with coils.

Order details	Bbn	Price	Price group	Weight	Pack unit
Type code	Order code	1 piece		1 piece	kg
	EAN				pc.
SQZ3	2CSM111310R1331	372004		0.300	1

Wiring diagram

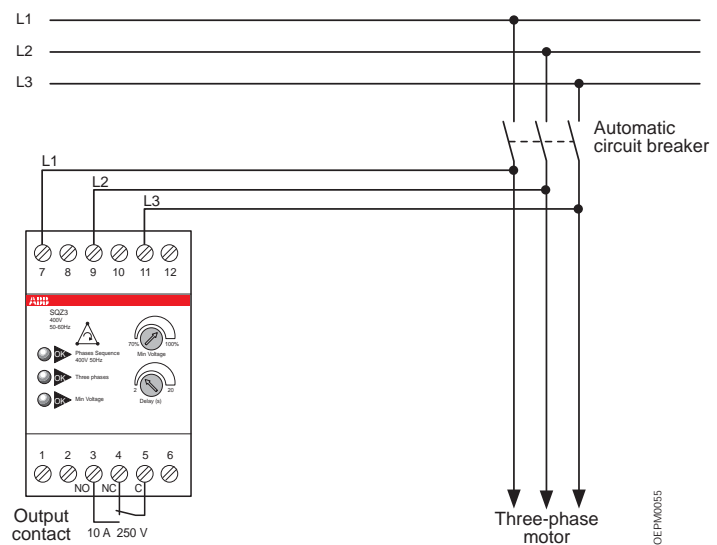

Technical features

Supply voltage	[Vn]	400 V a.c.
Frequency	[Hz]	50/60
Contact capacity	[A]	10 (cosφ=1)
Contact type		safety switching, changeover
Minimum voltage regulating trimmer	[%]	from 100 to 70 of Vn
Intervention delay regulating trimmer	[s]	from 2 to 20 (only for min. voltage)
Insulation rating		II
Protection degree	[IP]	20
Operating temperature	[°C]	-10...+55
Power consumption	[W]	10
Modules	[n°]	3



LEE 230 power failure signalling extractable lamp

The LEE 230 lamp is an automatic electronic lamp to be installed in any modular socket or wiring accessories socket with German standard VDE Schuko (M1173 or E1175) and Italian standard P11, 10 A or dual standard 10/16 A.

The device can operate as a power failure signalling lamp as well as a lighting device, to be used for example during maintenance activities or for looking for possible faults in the panel.

Pack	Order details		Bbn	Price	Price	Weight	Pack
	Type code	Order code	8012542	1 piece	group	1 piece	unit
			EAN			kg	pc.
Box	LEE-230	2CSM110000R1361	844105			0.100	1/6
Blister	LEE-230	2CSM111000R1361	507406			0.100	1

Technical features

2P 10 A plug		distance between pins 19 mm, pin ø 4 mm
Supply	[V]	230 a.c., 50-60 Hz
Recharge time	[h]	24
Endurance	[h]	3
Lighting level	[mcd]	3000
Operating temperature	[°C]	0...+45
Min. life cycle		5 years (battery)

Additional technical features

The LEE-230 lamp automatically switches on when the voltage fails; the built-in rechargeable battery guarantees the supply.

It is particularly useful thanks to its construction and functional characteristics:

- it can be extracted from the socket and used as a torch with ON-OFF button on its frontal side
- when necessary it can work with standard sockets
- it can be moved when it is needed
- it has a long operation endurance, up to three hours
- it is ready to use, it does not require installation
- with a screw (ø 3.5 mm, L 16 mm) it is possible to fix it preventing the extraction from the M1173 ABB sockets with central hole
- the projecting part of the Schuko profile is very small (8 mm).

The two LEDs placed on the frontal side of the lamp indicate its operation condition:

- the red LED indicates the recharge activity and that, in the case of a network voltage back-out, the lamp will remain off
- the green LED indicates the recharge activity and that, in the case of a network voltage black-out, the lamp will switch on (it will automatically switch off when the voltage returns).

By pushing the frontal pushbutton it is possible to change the status; if you do not use the lamp for a prolonged time it is suggested to set the first condition in order to preserve the battery life.



Max./min. current/voltage ammetric and voltmetric relays

These devices are used to measure current (ammetric) and voltage (voltmetric) on single-phase electric networks for a perfect protection of devices used.

The range includes:

- **maximum current (RHI) and maximum voltage (RHV) relay.** The control relay remains on as long as the quantity to be measured is lower than the set threshold value;
- **minimum current (RLI) and minimum voltage (RLV) relay.** The control relay remains on as long as the quantity to be measured is higher than the set threshold value.

In both cases the relay switches off with a delay adjustable by the potentiometer, which also allows to adjust hysteresis (from 1 to 45%).

Type	Order details	Bbn 8012542	Price 1 piece	Price group	Weight 1 piece	Pack unit
	Type code	Order code	EAN		kg	pc.
maximum current ammetric relay	RHI	2CSM121310R1321	334309		0.300	1
maximum voltage voltmetric relay	RHV	2CSM111310R1321	334101		0.300	1
minimum current ammetric relay	RLI	2CSM122310R1321	334200		0.300	1
minimum voltage voltmetric relay	RLV	2CSM112310R1321	334002		0.300	1

Technical features

Rated voltage U_n	[V]	a.c. 230
Switching contact capacity	[A]	16
Rated frequency	[Hz]	50/60
Ammetric relay alarm thresholds	[A]	2, 5, 10
Voltmetric relay alarm thresholds	[V]	100, 300, 500
Adj. calibration of I_n and $V_n\%$	[%]	30...100
Adjustable hysteresis value	[%]	1...45
Time delay	[s]	1...30
Power consumption	[W]	2
Modules	[n°]	3

Additional technical features

Control relay intervention lighting indication	red LED on=intervening
Power supply lighting indication	green LED on=ON
Intervention lighting indication	blinking green LED=intervening

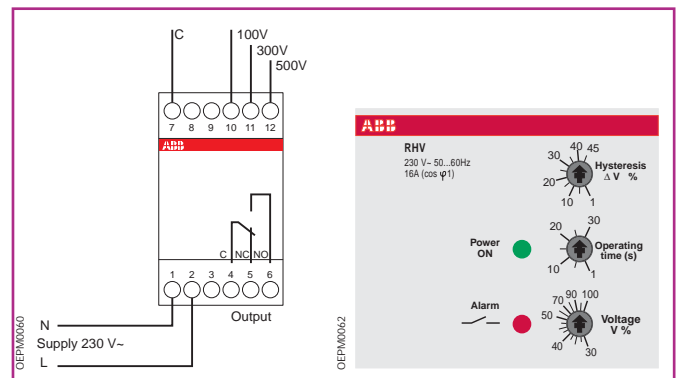
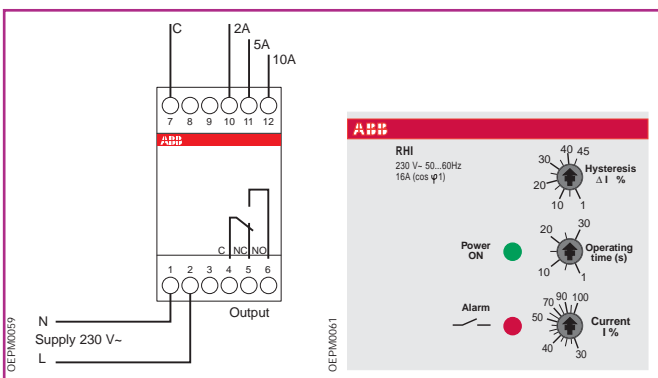



E 235 mains disconnection relays - Bioswitch

Constant exposure of electrical interference fields originating from live conductors - as is the case e.g. in bedrooms - may impair the well-being of people, experts say.

With the extra base load adapter E235-GLA, the mains disconnection relays can be switched on manually.

For the permanent installation of loads that switch on independently of the supply voltage, such as fluorescent lamps, a E235-GLE PTC base load element is available.

Description	Order details		Bbn	Price	Price	Weight	Pack
	Type code	Order code	4016779	1 piece	group	1 piece	unit
			EAN			kg	pc.
mains disconnection relay	E 235-NFS	2CDE110000R1701	571821			0.065	1
base load element	E 235-GLE	2CDE100500R1711	571814			0.001	1
base load adapter	E 235-GLA	2CDE100510R1711	571869			0.070	1

Wiring diagram

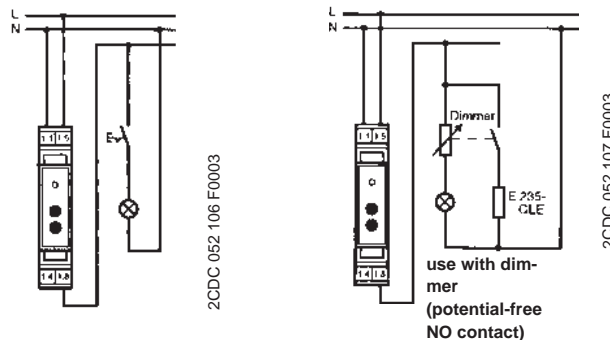

Technical features

Short circuit rupturing capacity	16 A/230 V a.c.
Rated frequency	50/60 Hz
Range of control voltage	0.9 to 1.1 Un
Load of filament lamps	2300 W
Fluorescent lamp load:	
twin lamp circuit	100 W
shunt compensated	56 W
electronic ballast	max. 36 W, dependent on manufacturer
Induce load	6 A cosφ = 0.6
Max. switching capacity (cosφ 0.5)	3500 VA
Intrinsic consumption ca. 1 W	
Control voltage	5 V a.c.
Adjustable making capacity	2 - 15 VA
Breaking capacity	0.66 x making capacity
ON delay	50 ms
OFF delay	ca. 3 sec.
Contact assembly	1 NO contact
Service life at rated load	> 100000 switching cycles
Ambient temperature	- 10 °C/14 °F to +45 °C/113 °F
Connection capacity (clamping terminal)	max 2.5 mm ²



E 236 undervoltage monitoring relays

Function

The green LED is lit when the supply voltage is applied. If each phase voltage exceeds 195 V (US1) or exceeds the preset threshold value (US2) with respect to the neutral including the hysteresis when switching the device on, the relay switches immediately into the working position. The yellow LED is lit. If at least one phase voltage falls below the threshold value, the relay goes back into its normal position and the yellow LED goes out.

If also phase 2 fails, the green LED goes out, too.

It is indispensable to connect the neutral conductor!

Application

For the control of three-phase undervoltage (each phase to neutral) of switchgear, also for installations according to DIN VDE 0107 (power installations in hospitals and rooms used for medical purposes outside of hospitals) and DIN VDE 0108 (power installations and safety supply in buildings where many people gather).

US 1: 3 phases to neutral with fixed threshold at 195V; hysteresis fixed 5 %

US 2: 3 phases to neutral with fixed threshold at 160 – 240V; hysteresis fixed 5 %

Technical features

Rated voltage	250 V a.c.
Frequency	48-63 Hz
Measuring range:	supply voltage 3N 400/230 V a.c. (terminals N-L1-L2-L3)
	overload capacity 3N 459/265 V a.c.
Switching capacity	device in series (distance < 5 mm): 750 VA (3 A/250 V a.c.); device not in series (distance > 5 mm): 1250 VA (5 A/250 V a.c.)
Rated insulation voltage	250 V a.c. (corresponds with IEC 664-1)
Rated surge voltage	4 kV
Tripping delay	ca. 100 ms
Creepage and creepage distance	> 6 mm (between contact and electronics)
Mechanical service life	20 x 10 ⁶ operations
Electrical service life at 10000VA	2 x 10 ⁵ operations
Max. switching rate	max. 6/min (1000 VA Ohmic load); max. 60/min (100 VA Ohmic load)
Ambient temperature	-25 °C/-13 °F to +55 °C/131 °F
Overvoltage category	III
Accuracy in non-changing environment:	
	setting tolerance (US 2) ≤5 %
	repeat accuracy ±1 %
	temperature effect ≤0.1 %/°C
Terminals	up to 4 mm ²
Specifications	VDE 0110 and VDE 0435
EMC tests	EM 50081-1 and EN 50082-2
Displays	LED green= supply voltage applied; LED yellow= relay status
Power loss	1.7 W



Contact	Order details		Bbn 4016779	Price 1 piece	Price group	Weight 1 piece	Pack unit
	Type code	Order code	EAN			kg	pc.
2CO	E 236-US 1	2CDE165000R2001	511087			0.095	5
2CO	E 236-US 2	2CDE165010R2001	511094			0.095	5

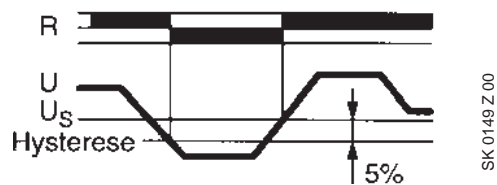
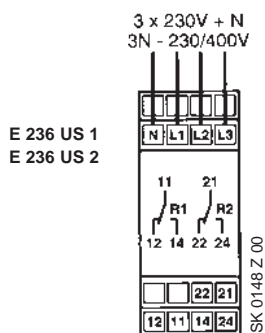

Index

Selection tables	
Analogue instruments.....	9/2
Digital instruments.....	9/4
DMTME multimeters.....	9/6
Accessories for analogue and digital instruments	
MCV-MCA voltmetric and ammetric switches.....	9/8
Interchangeable scales.....	9/9
CT current transformers.....	9/10
CTSM summing current transformers.....	9/21
TV voltage transformers.....	9/22
CONV current and voltage converters.....	9/25
CNV transducers.....	9/26
Shunts.....	9/27
E 233 hour counters.....	9/29
HMT hour counters.....	9/30
Isoltester-DIG insulation monitors.....	9/31
Selvtester insulation monitor.....	9/33
QSD panels for Isoltester-DIG and Selvtester.....	9/33
EMT electronic energy meter.....	9/34
ODINsingle electronic single phase energy meters.....	9/35
ODIN Meter electronic three-phase energy meters.....	9/37
DELTAsingle electronic single phase energy meters.....	9/39
DELTAplus electronic three-phase energy meters.....	9/41
Accessories for electronic energy meters.....	9/43

The range provided includes analogue and digital instruments. In addition to standard measurement devices for electric quantities (voltmeters, ammeters, wattmeters, varmeters, frequency meters, power factor meters), other special instruments (RPM meters, hour meters) and a set of accessories are available, including ammetric transformers, which increase the functions of these instruments.

Analogue instruments for alternated current

Suitable for direct or indirect measurement through the appropriate accessories.

Scale	Order details	Bbn	Price	Price	Weight	Pack
	Type code	Order code	1 piece	group	1 piece	unit
		EAN			kg	pc.

Direct voltmeters

300 V	VLM1/300	2CSM110190R1001	007906		0.200	1
500 V	VLM1/500	2CSM110220R1001	000006		0.200	1

Direct ammeters

5 A	AMT1/5	2CSM310030R1001	000709		0.200	1
10 A	AMT1/10	2CSM310040R1001	000105		0.200	1
15 A	AMT1/15	2CSM310050R1001	000204		0.200	1
20 A	AMT1/20	2CSM310060R1001	000303		0.200	1
25 A	AMT1/25	2CSM310070R1001	000402		0.200	1
30 A	AMT1/30	2CSM310080R1001	000501		0.200	1

Ammeters without scale for C.T. (sec. 5 A)

For scale (SCL1)	Order details	Bbn	Price	Price	Weight	Pack
	Type code	Order code	1 piece	group	1 piece	unit
		EAN			kg	pc.
A1	AMT1/A1	2CSM320250R1001	000600		0.200	1
A5	AMT1/A5	2CSM320260R1001	000808		0.200	1

100/280V 45-65 Hz frequency meter with scale

Order details	Bbn	Price	Price	Weight	Pack
Type code	Order code	EAN	1 piece	group	1 piece
					kg
FRZ1	2CSM810310R1001	008606			0.200

Power factor meter with scale for transducer (1 mA input)

Order details	Bbn	Price	Price	Weight	Pack
Type code	Order code	EAN	1 piece	group	1 piece
					kg
CSF1	2CSM720310R1001	028000			0.300

Technical features

Rated voltage Un	[V]	a.c. 300, 500; d.c. 100, 300
Rated currents in a.c.	Direct reading [A]	full scale values 5...30
	Indirect reading	full scale values 5...2500
Rated currents in d.c.	Direct reading [A]	full scale values 0.1...30
	Indirect reading	full scale values 5...500
Frequency	[Hz]	50/60
Overload capacity	[%]	20 compared to the voltage or to the rated current
Accuracy class	[%]	1.5 (0.5 for frequency meters)
Power consumption	[W]	see technical details
Modules	[n°]	3
Standards		EN 60051



2CSC400497F0201



2CSC400517F0201

Analogue instruments for direct current

Scale	Order details	Bbn	Price	Price group	Weight	Pack unit
	Type code	Order code	1 piece		1 piece	pc.
					kg	

Direct voltmeters

100 V	VLM2/100	2CSM210130R1001	008002		0.200	1
200 V	VLM2/300	2CSM210190R1001	008101		0.200	1

Direct ammeters

10 mA	AMT2/0.01	2CSM410330R1001	028307		0.200	1
100 mA	AMT2/0.1	2CSM410340R1001	028406		0.200	1
1000 mA	AMT2/1	2CSM410020R1001	028505		0.200	1
5 A	AMT2/5	2CSM410030R1001	028604		0.200	1
10 A	AMT2/10	2CSM410040R1001	028703		0.200	1
15 A	AMT2/15	2CSM410050R1001	028802		0.200	1
20 A	AMT2/20	2CSM410060R1001	028901		0.200	1
25 A	AMT2/25	2CSM410070R1001	029007		0.200	1
30 A	AMT2/30	2CSM410080R1001	029106		0.200	1

Ammeters without (SCL2) scale for shunt.../60 mV

Order details	Bbn	Price	Price group	Weight	Pack unit
Type code	Order code	1 piece		1 piece	pc.
				kg	
AMT2	2CSM420270R1001	029205		0.200	1

Wiring diagrams

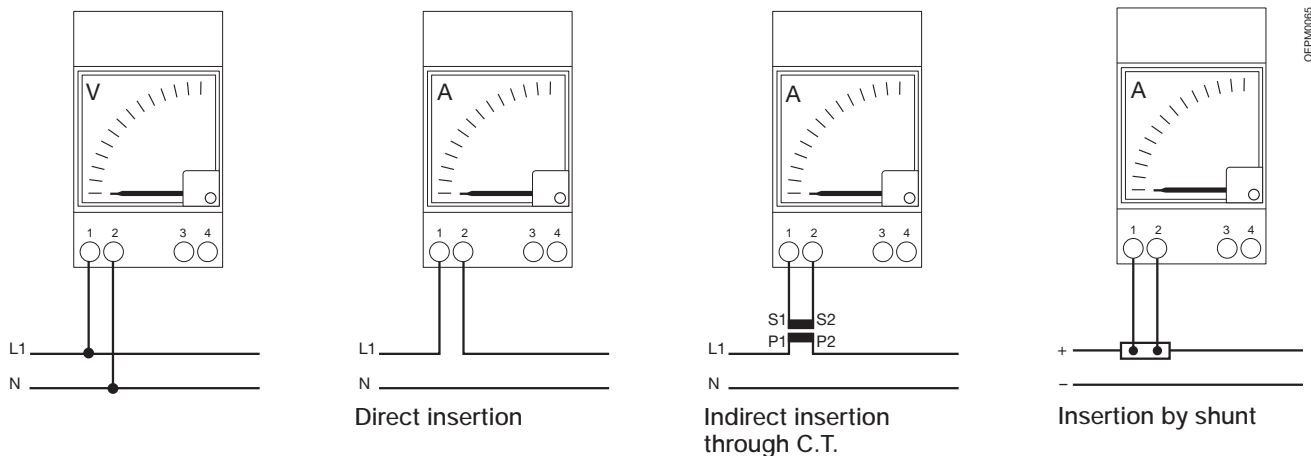



Suitable for direct or indirect measurement using appropriate accessories.

Measurements are displayed through 3-digit digital indicator with out-of-scale signalling.

As electronic instruments do not have parts subject to friction wear, they have a longer operation life and high accuracy.

Measuring instruments with digital display, class 0.5

Effective range	Power loss	Order details		Bbn 8012542	Price 1 piece	Price group	Weight 1 piece	Pack unit
0-...	W	Type code	Order code	EAN			kg	pc.

Measuring instruments for alternating or direct voltage (direct measurement)

600 V AC/DC	2.0	VLMD-1-2	2CSM110000R1011	62040 2			0.300	1
-------------	-----	----------	-----------------	---------	--	--	-------	---

Ammeter for C.T. .../5A (alternating current)

15-20-25-40-60 99.9-150-200 250-400-600-999 A	2.0	AMTD-1	2CSM320000R1011	62050 1			0.300	1
---	-----	--------	-----------------	---------	--	--	-------	---

Ammeter for shunt (direct current)

15-20-25-40-60 99.9-150-200 250-400-600-999 A	2.0	AMTD-2	2CSM420000R1011	62060 0			0.300	1
---	-----	--------	-----------------	---------	--	--	-------	---

Measuring instruments for frequencies (direct measurement)

40 ... 80 Hz	2.0	FRZ-DIG	2CSM710000R1011	62070 9			0.300	1
--------------	-----	---------	-----------------	---------	--	--	-------	---

Technical features

Rated voltage	[V]	a.c. 230
Rated frequency	[Hz]	50÷400
Overload capacity	[In/Vn]	1.2
Accuracy rating	[%]	±0.5 full scale ±1 digit at 25 °C
Max. signal input value		5 A a.c./60 mV d.c
Measurement field		VLM-D1 VLM-D2 0...999 A AMTD1 ATD2 0...999 A FRZ-DIG 40...80 Hz (0.5% rating)
Selection of capacity		continuous through menu pushbuttons
View		3-digit display+LED for out-of scale signalling
Operating temperature	[°C]	-10...+55
Storage temperature	[°C]	-40...+70
Protection degree	[IP]	20
Power consumption	[VA]	<2
Modules	[n°]	3
Standards		CEI EN 61010

Wiring diagrams

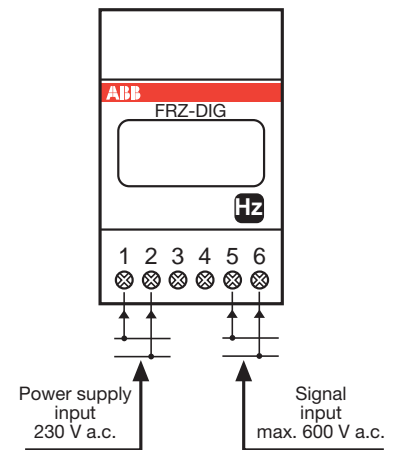
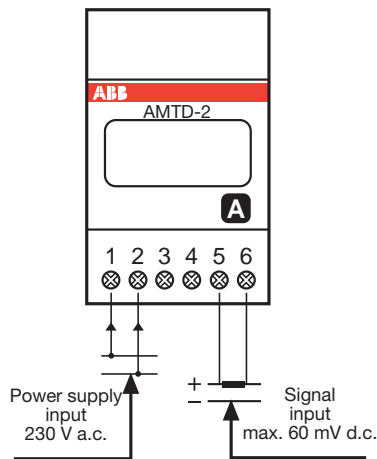
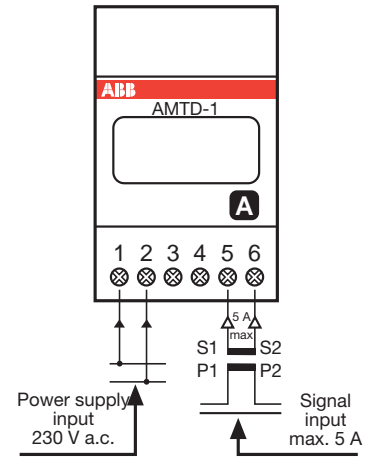
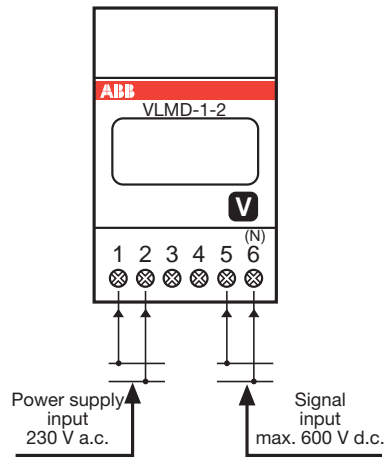

OEPW0066

9

Full scale calibration

Press the set up pushbutton for 3 seconds until the display blinks, then press repeatedly the pushbutton until viewing the desired full scale (3 lines=5 A full scale). Then press again the pushbutton for 3 seconds for saving the selected setting.



DMTME multimeters

The instruments DMTME are digital multimeters that allow the measurement (in TRMS mode) of the principal electrical parameters in three-phase 230/400Vac networks, including the max/min/average detection of the main electrical parameters and the active and reactive energy count. The different measured variables are displayed locally on four red 7-segment LED displays providing easy readability and simultaneous display of multiples measures. The instruments DMTME combine also (in a single instrument) the functions of a voltmeter, ammeter, power factor meter, wattmeter, varmeter, frequency meter, active and reactive energy meters, allowing remarkable financial savings thanks to the reduction of space required for the panels and also of time required for cabling.

DMTME modular multimeters (6 modules)

Type	Order details	Bbn	Price	Price	Weight	Pack
	Type code	Order code	1 piece	group	1 piece	unit
		EAN			kg	pc.
for measurement at 230/400 VAC, insertion through CT.../5A	DMTME	2CSM170040R1021	975700		0.450	1
for measurement at 230/400 VAC + output RS485 + MODBUS RTU + relay output	DMTME-I-485	2CSM180050R1021	975809		0.450	1

Accessories for DMTME modular multimeters (6 modules)

Type	Order details	Bbn	Price	Price	Weight	Pack
	Type code	Order code	1 piece	group	1 piece	unit
		EAN			kg	pc.
converter RS485-232	CUS	2CSM200000R1031	333807		0.050	1

Technical features

Dimensions (LxHxW)	6 DIN rail model: 105 mm x 90 mm x 63 mm	
Weight	About 350g	
Protection	IP50 on the front panel IP20 on the terminal blocks	
Power-supply	230V rms (+15% -10%)	
Voltage	240V rms (+10% -15%) 115V rms (+15% -10%) 120V rms (+10% -15%)	
Frequency	45 ÷ 65Hz	
Power consumption	< 6VA	
Fuse	Fit external fuse T0,1A	
Voltmeter inputs	Range	5 ÷ 500V rms (L-N)
	Max non-destructive value	550V rms
	L-N input impedance	Greater than 8M
Ammeter inputs (use always external CTs)	Range	50mA ÷ 5A rms
	Overload	1.1 permanent
	Max dispersed power (with I _{max} = 5A rms), for each phase input	1.4VA
Type of measurement	Current inputs through internal shunts and using external CTs	
Direction of CTs current	Detection and automatic adjustment at power up, independent for each phase	
Maximum value for the single-phase energy	4294.9 MWh (MVAh) with KA = KV = 1	
Maximum value for the three-phase energy	4294.9 MWh (MVAh) with KA = KV = 1	
Accuracy	Class 1	
Operating temperature	0°C ÷ 50°C	
Storage temperature	-10°C ÷ 60°C	
Relative humidity	90% max. (without condense) at 40°C	
Standard	IEC / EN 61010-1	

Wiring diagrams

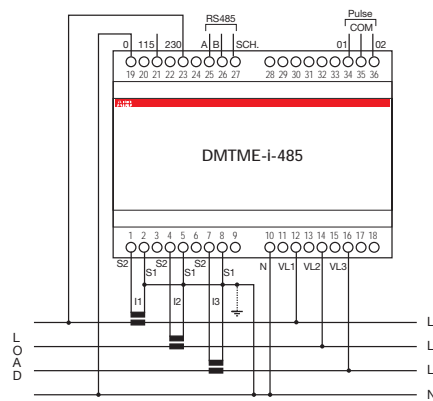

Three phase direct connection

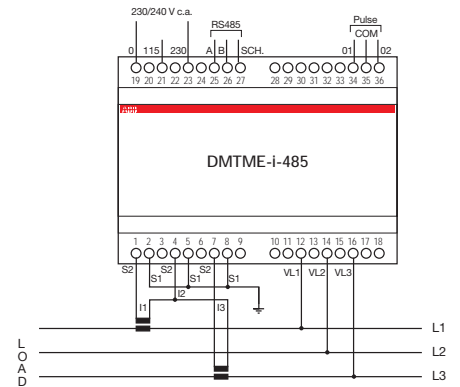

Three phase direct connection without neutral with 2 CTs

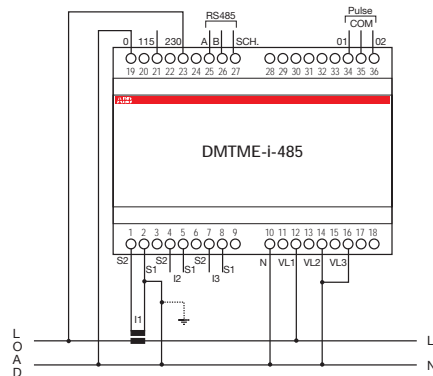

Single phase direct connection



MCV - MCA voltmetric and ammetric switches

Cam rotary switches are suitable for mounting on EN 50022 rail. In three-phase systems they enable the use of a single measurement instrument (single-phase) for viewing the current or voltage value set through the switch itself.

Range	Power loss W	Order details Type code	Order code	Bbn 4034656 EAN	Price 1 piece	Price group	Weight 1 piece kg	Pack unit pc.
-------	-----------------	----------------------------	------------	-----------------------	------------------	----------------	-------------------------	---------------------

Voltmeter changeover switches

L1, L2, L3	0.5	MCV 4	1SCA 022 404 R4740	52246 9			0.095	1
L1, L2, L3, N	0.5	MCV 7	1SCA 022 647 R7840	52243 8			0.110	1

Ammeter changeover switches

0-1-2-3	0.5	MCA 4	1SCA 022 404 R4821	52245 2			0.110	1
---------	-----	-------	--------------------	---------	--	--	-------	---

9

Technical features

Insulation voltage	[V]	600
Rated thermal current	[A]	12
Mechanic operations	[n°]	1000000
Power consumption	[W]	0.23
Modules	[n°]	3

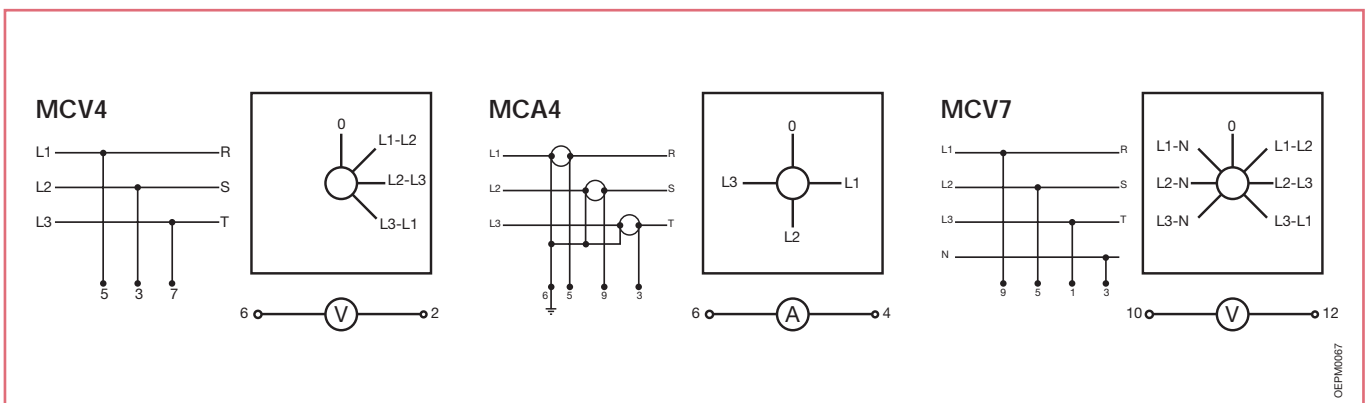

OEPM0067

Interchangeable scales for analogue instruments

Scale	Order details	Bbn	Price	Price group	Weight	Pack unit
	Type code	Order code	1 piece		1 piece	pc.
		EAN			kg	

Interchangeable scales for analogue ammeters in a.c. AMT1

A1-5A	SCL 1/5	2CSM110021R1041	001201		0.010	10
A1-10A	SCL 1/10	2CSM110032R1041	001300		0.010	10
A1-20A	SCL 1/20	2CSM110075R1041	001409		0.010	10
A1-25A	SCL 1/25	2CSM110096R1041	030706		0.010	10
A1-30A	SCL 1/30	2CSM110107R1041	001508		0.010	10
A1-40A	SCL 1/40	2CSM110128R1041	030805		0.010	10
A1-50A	SCL 1/50	2CSM110149R1041	001607		0.010	10
A1-60A	SCL 1/60	2CSM110159R1041	030904		0.010	10
A1-75A	SCL 1/75	2CSM110169R1041	031000		0.010	10
A1-80A	SCL 1/80	2CSM110179R1041	001706		0.010	10
A1-100A	SCL 1/100	2CSM110189R1041	001805		0.010	10
A1-150A	SCL 1/150	2CSM110209R1041	001904		0.010	10
A1-200A	SCL 1/200	2CSM110229R1041	002000		0.010	10
A1-250A	SCL 1/250	2CSM110249R1041	031109		0.010	10
A1-300A	SCL 1/300	2CSM110259R1041	002109		0.010	10
A1-400A	SCL 1/400	2CSM110279R1041	002208		0.010	10
A1-500A	SCL 1/500	2CSM110299R1041	002307		0.010	10
A1-600A	SCL 1/600	2CSM110309R1041	031208		0.010	10
A1-800A	SCL 1/800	2CSM110329R1041	002406		0.010	10
A1-1000A	SCL 1/1000	2CSM110339R1041	002505		0.010	10
A1-1500A	SCL 1/1500	2CSM110359R1041	274704		0.010	10
A1-2000A	SCL 1/2000	2CSM110379R1041	274803		0.010	10
A1-2500A	SCL 1/2500	2CSM110389R1041	274902		0.010	10
A5-5A	SCL 1/A5/5	2CSM120021R1041	031307		0.010	10
A5-10A	SCL 1/A5/10	2CSM120032R1041	031406		0.010	10
A5-20A	SCL 1/A5/20	2CSM120075R1041	031505		0.010	10
A5-30A	SCL 1/A5/30	2CSM120107R1041	031604		0.010	10
A5-50A	SCL 1/A5/50	2CSM120149R1041	031703		0.010	10
A5-80A	SCL 1/A5/80	2CSM120179R1041	031802		0.010	10
A5-100A	SCL 1/A5/100	2CSM120189R1041	031901		0.010	10
A5-150A	SCL 1/A5/150	2CSM120209R1041	032007		0.010	10



2CSC400521F0201

SCL1/A1/100
Full scale at 90°

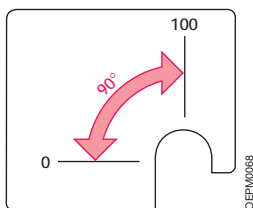

© EPFMA0088

SCL1/A5/100
Full scale at 78°
(with extra scale)

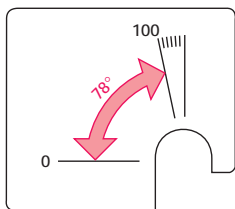

Interchangeable scales for analogue ammeters in d.c. AMT2

A1-5A	SCL 2/5	2CSM230025R1041	032106		0.010	10
A1-6A	SCL 2/6	2CSM230345R1041	032205		0.010	10
A1-10A	SCL 2/10	2CSM230035R1041	032304		0.010	10
A1-20A	SCL 2/20	2CSM230075R1041	032403		0.010	10
A1-30A	SCL 2/30	2CSM230105R1041	032502		0.010	10
A1-50A	SCL 2/50	2CSM230145R1041	032601		0.010	10
A1-80A	SCL 2/80	2CSM230179R1041	032700		0.010	10
A1-100A	SCL 2/100	2CSM230189R1041	032809		0.010	10
A1-150A	SCL 2/150	2CSM230209R1041	032908		0.010	10
A1-200A	SCL 2/200	2CSM230229R1041	033004		0.010	10
A1-250A	SCL 2/250	2CSM230249R1041	033103		0.010	10
A1-300A	SCL 2/300	2CSM230259R1041	033202		0.010	10
A1-400A	SCL 2/400	2CSM230279R1041	033301		0.010	10
A1-500A	SCL 2/500	2CSM230299R1041	033400		0.010	10



Current transformers

Used to transform primary currents (max. 6000 A) into .../5 A low secondary currents indirectly supplying power to analogue and digital measurement devices. They are available both with wound and through primary. In the first case they are provided along with the bar or the primary terminal; in the second case they have a hole in the bar or the cable which forms the primary. They are available in .../1 A versions on request.

Modular current transformers with through primary E 29 mm, secondary .../5A

Primary rated current I _{prim}	Precision class - Rating power	Order details	Bbn 8012542	Price 1 piece	Price group	Weight 1 piece	Pack unit
A	-VA	Type code	Order code	EAN		kg	pc.
40	3-1	TRFM/40	2CSM100050R1111	046912		0.721	4
60	1-2	TRFM/60	2CSM100070R1111	047018		0.744	4
100	0.5-2	TRFM/100	2CSM100090R1111	047117		0.744	4
150	0.5-3	TRFM/150	2CSM100100R1111	047216		0.712	4
250	0.5-4	TRFM/250	2CSM100120R1111	047315		0.746	4
400	0.5-6	TRFM/400	2CSM100140R1111	047407		0.780	4
600	0.5-7	TRFM/600	2CSM100160R1111	047506		0.859	4

Technical features

Standard secondary current	[A]	5 (other secondary on request)
Max. voltage for operation ①	[kV]	1.2 (0.72 for compact version)
Test voltage ②	[kV]	6 at 50 Hz/1 min. (3 for compact version)
Short circuit rated thermal current I _{min} ③	[IpN]	40 for 1 sec.
Short circuit rated dynamic current I _{min} ④	[I _{per}]	2.5 for 1 sec.
Permanent overload	[IpN]	1.2
Safety factor ⑤	[Fs]	≤2 at ≤10 according to version and capacity
Frequency	[Hz]	50/60
Air insulation		E class
Terminals ⑥		primary = P1, P2 (K-L) secondary = s1, s2 (k-l) P1 (K)=primary wound input P2 (L)=primary wound output s1 (k)=secondary wound input s2 (l)=secondary wound output with double ration on secondary s1-s2=lower ratio, s1-s3=higher ratio
Housing		ABS resin
Protection degree		IP30
Operating temperature	[°C]	-20...+50
Max. temperature on bars	[°C]	+70
Storage temperature	[°C]	-40...+80
Relative humidity		80%

① Max. voltage (effective value) the transformer can bear.

② Industrial frequency voltage in relation to insulation the transformer bears for 1 min. between the primary and the secondary.

③ Max. primary current (effective value) the transformer bears for 1 sec. with counter-circuited secondary without overload-induced damages.

④ Max. primary current (effective value) the transformer bears for 1 sec. with counter-circuited secondary without damaged due to electromagnetic efforts.

⑤ Ratio between primary current causing nucleus saturation and the rated primary current value: the lower the Sf the higher the protection level on the transformer.

⑥ Brass terminals CuZn37, M4x6 screws with torsion value 1.9 Nm, tensile value 440 N/mm² and elasticity limit 340 N/mm².

During the installation control the correct input (P1-K) and output (P2-L) direction of the primary cable.

On versions with primary and secondary on terminals pay attention the connection of the primary with the secondary is not inverted.

In the case of a detachment from measurement devices of the transformer in a connected plant counter-circuit the two terminals of the transformer.

It is suggested to earth the transformers.

Current transformer.../5 A with wound primary, primary and secondary current on terminals



Primary rated current I _{prim}	Precision class - Rating power	Order details	Bbn 8012542	Price 1 piece	Price group	Weight 1 piece	Pack unit
A	-VA	Type code	Order code	EAN		kg	pc.
5	0.5-5 and 1-7	CTA/5	2CSG111020R1141	661306		0.290	1
10	0.5-5 and 1-7	CTA/10	2CSG111030R1141	661405		0.290	1
15	0.5-5 and 1-7	CTA/15	2CSG111040R1141	661504		0.290	1
20	0.5-5 and 1-7	CTA/20	2CSG111050R1141	661603		0.290	1
25	0.5-5 and 1-7	CTA/25	2CSG111060R1141	661702		0.290	1
40	0.5-5 and 1-7	CTA/40	2CSG111080R1141	661801		0.290	1
50	0.5-5 and 1-7	CTA/50	2CSG111090R1141	661900		0.290	1
60	0.5-5 and 1-7	CTA/60	2CSG111100R1141	662006		0.290	1
80	0.5-5 and 1-7	CTA/80	2CSG111110R1141	662105		0.290	1
100	0.5-5 and 1-7	CTA/100	2CSG111120R1141	662204		0.290	1
5	0.5-10 and 1-20	CTA1/5	2CSG211020R1141	662303		0.440	1
10	0.5-10 and 1-20	CTA1/10	2CSG211030R1141	662402		0.440	1
15	0.5-10 and 1-20	CTA1/15	2CSG211040R1141	662501		0.440	1
20	0.5-10 and 1-20	CTA1/20	2CSG211050R1141	662600		0.440	1
25	0.5-10 and 1-20	CTA1/25	2CSG211060R1141	662709		0.440	1
40	0.5-10 and 1-20	CTA1/40	2CSG211080R1141	662808		0.440	1
50	0.5-10 and 1-20	CTA1/50	2CSG211090R1141	662907		0.440	1
60	0.5-10 and 1-20	CTA1/60	2CSG211100R1141	663003		0.440	1
80	0.5-10 and 1-20	CTA1/80	2CSG211110R1141	663102		0.440	1
100	0.5-10 and 1-20	CTA1/100	2CSG211120R1141	663201		0.440	1
150	0.5-10 and 1-20	CTA1/150	2CSG211130R1141	663300		0.440	1
200	0.5-10 and 1-20	CTA1/200	2CSG211140R1141	663409		0.440	1
250	0.5-10 and 1-20	CTA1/250	2CSG211150R1141	663508		0.440	1
300	0.5-10 and 1-20	CTA1/300	2CSG211160R1141	663607		0.440	1
400	0.5-10 and 1-20	CTA1/400	2CSG211170R1141	663706		0.440	1
500	0.5-10 and 1-20	CTA1/500	2CSG211180R1141	663805		0.440	1
5	0.5-10 and 1-35	CTA2/5	2CSG311020R1141	663904		0.440	1
10	0.5-10 and 1-35	CTA2/10	2CSG311030R1141	664000		0.440	1
15	0.5-10 and 1-35	CTA2/15	2CSG311040R1141	664109		0.440	1
20	0.5-10 and 1-35	CTA2/20	2CSG311050R1141	664208		0.440	1
25	0.5-10 and 1-35	CTA2/25	2CSG311060R1141	664307		0.440	1
40	0.5-10 and 1-35	CTA2/40	2CSG311080R1141	664406		0.440	1
50	0.5-10 and 1-35	CTA2/50	2CSG311090R1141	664505		0.440	1
60	0.5-10 and 1-35	CTA2/60	2CSG311100R1141	664604		0.440	1
80	0.5-10 and 1-35	CTA2/80	2CSG311110R1141	664703		0.440	1
100	0.5-10 and 1-35	CTA2/100	2CSG311120R1141	664802		0.440	1
150	0.5-10 and 1-35	CTA2/150	2CSG311130R1141	664901		0.440	1
200	0.5-10 and 1-35	CTA2/200	2CSG311140R1141	665007		0.440	1
250	0.5-10 and 1-35	CTA2/250	2CSG311150R1141	665106		0.440	1
300	0.5-10 and 1-35	CTA2/300	2CSG311160R1141	665205		0.440	1
400	0.5-10 and 1-35	CTA2/400	2CSG311170R1141	665304		0.440	1
500	0.5-10 and 1-35	CTA2/500	2CSG311180R1141	665403		0.440	1
40	3-2	CT3/40	2CSG121060R1101	602408		0.340	1
50	3-2	CT3/50	2CSG121070R1101	602507		0.340	1
60	3-2	CT3/60	2CSG121080R1101	602606		0.340	1
80	3-3	CT3/80	2CSG121090R1101	602705		0.340	1
100	1-3	CT3/100	2CSG121100R1101	602804		0.340	1
150	0.5-3	CT3/150	2CSG121110R1101	602903		0.340	1
200	0.5-3	CT3/200	2CSG121120R1101	603009		0.340	1
250	0.5-6	CT3/250	2CSG121130R1101	603108		0.340	1
300	0.5-6	CT3/300	2CSG121140R1101	603207		0.340	1
400	0.5-6	CT3/400	2CSG121150R1101	603306		0.340	1
500	0.5-6	CT3/500	2CSG121160R1101	603405		0.340	1
600	0.5-6	CT3/600	2CSG121170R1101	603504		0.340	1



Primary rated current I _{prim}	Precision class - Rating power	Order details		Bbn 8012542	Price 1 piece	Price group	Weight 1 piece	Pack unit
A	-VA	Type code	Order code	EAN			kg	pc.
100	1-3	CT4/100	2CSG221100R1101	603603			0.390	1
150	1-3	CT4/150	2CSG221110R1101	603702			0.390	1
200	0.5-4	CT4/200	2CSG221120R1101	603801			0.390	1
250	0.5-6	CT4/250	2CSG221130R1101	603900			0.390	1
300	0.5-6	CT4/300	2CSG221140R1101	604006			0.390	1
400	0.5-10	CT4/400	2CSG221150R1101	604105			0.390	1
500	0.5-10	CT4/500	2CSG221160R1101	604204			0.390	1
600	0.5-10	CT4/600	2CSG221170R1101	604303			0.390	1
800	0.5-10	CT4/800	2CSG221180R1101	604402			0.390	1
1000	0.5-10	CT4/1000	2CSG221190R1101	604501			0.390	1
250	0.5-3	CT5/250	2CSG321130R1101	604600			0.430	1
300	0.5-4	CT5/300	2CSG321140R1101	604709			0.430	1
400	0.5-6	CT5/400	2CSG321150R1101	604808			0.430	1
500	0.5-10	CT5/500	2CSG321160R1101	604907			0.430	1
600	0.5-10	CT5/600	2CSG321170R1101	605003			0.430	1
800	0.5-10	CT5/800	2CSG321180R1101	605102			0.430	1
1000	0.5-10	CT5/1000	2CSG321190R1101	605201			0.430	1
1200	0.5-10	CT5/1200	2CSG321200R1101	605300			0.430	1
1500	0.5-20	CT5/1500	2CSG321220R1101	605409			0.430	1
250	0.5-5	CT6/250	2CSG421130R1101	605508			0.430	1
300	0.5-5	CT6/300	2CSG421140R1101	605607			0.430	1
400	0.5-6	CT6/400	2CSG421150R1101	605706			0.430	1
500	0.5-6	CT6/500	2CSG421160R1101	605805			0.430	1
600	0.5-10	CT6/600	2CSG421170R1101	605904			0.430	1
800	0.5-10	CT6/800	2CSG421180R1101	606000			0.430	1
1000	0.5-20	CT6/1000	2CSG421190R1101	606109			0.430	1
1200	0.5-20	CT6/1200	2CSG421200R1101	606208			0.430	1
1500	0.5-30	CT6/1500	2CSG421220R1101	606307			0.430	1
2000	0.5-30	CT6/2000	2CSG421230R1101	606406			0.430	1
2500	0.5-30	CT6/2500	2CSG421240R1101	606505			0.430	1
300	0.5-5	CT8/300	2CSG521140R1101	606604			0.500	1
400	0.5-6	CT8/400	2CSG521150R1101	606703			0.500	1
500	0.5-10	CT8/500	2CSG521160R1101	606802			0.500	1
600	0.5-10	CT8/600	2CSG521170R1101	606901			0.500	1
800	0.5-10	CT8/800	2CSG521180R1101	607007			0.500	1
1000	0.5-10	CT8/1000	2CSG521190R1101	607106			0.500	1
1200	0.5-15	CT8/1200	2CSG521200R1101	607205			0.500	1
1500	0.5-20	CT8/1500	2CSG521220R1101	607304			0.500	1
2000	0.5-20	CT8/2000	2CSG521230R1101	607403			0.500	1
2500	0.5-20	CT8/2500	2CSG521240R1101	607502			0.500	1
3000	0.5-20	CT8/3000	2CSG521250R1101	607601			0.500	1
400	0.5-6	CT8-V/400	2CSG631150R1101	608707			0.500	1
500	0.5-10	CT8-V/500	2CSG631160R1101	608806			0.500	1
600	0.5-10	CT8-V/600	2CSG631170R1101	608905			0.500	1
800	0.5-10	CT8-V/800	2CSG631180R1101	609001			0.500	1
1000	0.5-10	CT8-V/1000	2CSG631190R1101	609100			0.500	1
1200	0.5-10	CT8-V/1200	2CSG631200R1101	609209			0.500	1
1500	0.5-10	CT8-V/1500	2CSG631220R1101	609308			0.500	1
2000	0.5-30	CT8-V/2000	2CSG631230R1101	609407			0.500	1
2500	0.5-30	CT8-V/2500	2CSG631240R1101	609506			0.500	1



CT12

2CSC400160F0201

500	0.5-10	CT12/500	2CSG721160R1101	607700	0.700	1
600	0.5-10	CT12/600	2CSG721170R1101	607809	0.700	1
800	0.5-15	CT12/800	2CSG721180R1101	607908	0.700	1
1000	0.5-20	CT12/1000	2CSG721190R1101	608004	0.700	1
1200	0.5-20	CT12/1200	2CSG721200R1101	608103	0.700	1
1500	0.5-20	CT12/1500	2CSG721220R1101	608202	0.700	1
2000	0.5-30	CT12/2000	2CSG721230R1101	608301	0.700	1
2500	0.5-40	CT12/2500	2CSG721240R1101	608400	0.700	1
3000	0.5-40	CT12/3000	2CSG721250R1101	608509	0.700	1
4000	0.5-50	CT12/4000	2CSG721260R1101	608608	0.700	1
5000	0.5-30	CT12/5000	2CSG721270R1101	745600	0.700	1
6000	0.5-30	CT12/6000	2CSG721280R1101	745709	0.700	1

800	0.5-10	CT12-V/800	2CSG831180R1101	609605	0.660	1
1000	0.5-10	CT12-V/1000	2CSG831190R1101	609704	0.660	1
1250	0.5-10	CT12-V/1200	2CSG831200R1101	609803	0.660	1
1200	0.5-10	CT12-V/1250	2CSG831210R1101	609902	0.660	1
1500	0.5-12	CT12-V/1500	2CSG831220R1101	610007	0.660	1
2000	0.5-15	CT12-V/2000	2CSG831230R1101	610106	0.660	1
2500	0.5-20	CT12-V/2500	2CSG831240R1101	610205	0.660	1

Compact type current transformer.../5 A with through primary

From cable ø 21 mm max.

40	3-2	CT-M1/40	2CSG121060R1151	665502	0.230	1
50	3-2	CT-M1/50	2CSG121070R1151	665601	0.230	1
60	3-2	CT-M1/60	2CSG121080R1151	665700	0.230	1
80	3-3	CT-M1/80	2CSG121090R1151	665809	0.230	1
100	1-3	CT-M1/100	2CSG121100R1151	665908	0.230	1
150	1-4	CT-M1/150	2CSG121110R1151	666004	0.230	1
200	0.5-3	CT-M1/200	2CSG121120R1151	666103	0.230	1
250	0.5-3	CT-M1/250	2CSG121130R1151	666202	0.230	1

From cable ø 23 mm max. or horizontal bar 20x12 - 25x15 - 30x10 mm

100	1-2	CT-M3/100	2CSG221100R1151	666301	0.230	1
150	1-3	CT-M3/150	2CSG221110R1151	666400	0.230	1
200	1-3	CT-M3/200	2CSG221120R1151	666509	0.230	1
250	0.5-2	CT-M3/250	2CSG221130R1151	666608	0.230	1
300	0.5-2	CT-M3/300	2CSG221140R1151	666707	0.230	1
400	0.5-3	CT-M3/400	2CSG221150R1151	666806	0.230	1

From cable ø 30 mm max. or horizontal/vertical bar 25x25 - 30x20 - 40x10 mm

100	1-3	CT-M4/100	2CSG321100R1151	666905	0.290	1
150	1-3	CT-M4/150	2CSG321110R1151	667001	0.290	1
200	0.5-4	CT-M4/200	2CSG321120R1151	667100	0.290	1
250	0.5-6	CT-M4/250	2CSG321130R1151	667209	0.290	1
300	0.5-6	CT-M4/300	2CSG321140R1151	667308	0.290	1
400	0.5-10	CT-M4/400	2CSG321150R1151	667407	0.290	1
500	0.5-10	CT-M4/500	2CSG321160R1151	667506	0.290	1
600	0.5-10	CT-M4/600	2CSG321170R1151	667605	0.290	1



CT-M1

2CSC400215F0201



CT-M3

2CSC400216F0201



CT-M4

2CSC400217F0201



CT-M5

2CSC400218F0201



CT-M6

2CSC400219F0201



CT-SM

2CSC400223F0201

Primary rated current I _{prim}	Precision class - Rating power	Order details		Bbn 8012542	Price 1 piece	Price group	Weight 1 piece	Pack unit
A	-VA	Type code	Order code	EAN			kg	pc.

From horizontal bar 50x12 mm

250	1-3	CT-M5/250	2CSG421130R1151	667704			0.290	1
300	0.5-4	CT-M5/300	2CSG421140R1151	667803			0.290	1
400	0.5-4	CT-M5/400	2CSG421150R1151	667902			0.290	1
500	0.5-6	CT-M5/500	2CSG421160R1151	668008			0.290	1
600	0.5-6	CT-M5/600	2CSG421170R1151	668107			0.290	1
800	0.5-10	CT-M5/800	2CSG421180R1151	668206			0.290	1
1000	0.5-10	CT-M5/1000	2CSG421190R1151	668305			0.290	1

From two cables (max. ø 22 mm) or from horizontal bar 50x23 - 60x20 mm

300	0.5-5	CT-M6/300	2CSG521140R1151	668404			0.380	1
400	0.5-6	CT-M6/400	2CSG521150R1151	668503			0.380	1
500	0.5-6	CT-M6/500	2CSG521160R1151	668602			0.380	1
600	0.5-6	CT-M6/600	2CSG521170R1151	668701			0.380	1
800	0.5-10	CT-M6/800	2CSG521180R1151	668800			0.380	1
1000	0.5-10	CT-M6/1000	2CSG521190R1151	668909			0.380	1
1200	0.5-15	CT-M6/1200	2CSG521200R1151	669005			0.380	1
1500	0.5-20	CT-M6/1500	2CSG521220R1151	669104			0.380	1

Miniaturized type current transformer.../5 A with through primary

From cable (max. ø 13 mm - minimum distance between cables = 27 mm)

40	3-2	CT-SM1/40	2CSG121060R1161	669203			0.210	1
50	3-2	CT-SM1/50	2CSG121070R1161	669302			0.210	1
60	3-3	CT-SM1/60	2CSG121080R1161	669401			0.210	1
75	3-3	CT-SM1/75	2CSG121090R1161	669500			0.210	1
80	3-3	CT-SM1/80	2CSG121100R1161	669609			0.210	1
100	1-3	CT-SM1/100	2CSG121110R1161	669708			0.210	1
120	1-5	CT-SM1/120	2CSG121120R1161	669807			0.210	1
125	1-5	CT-SM1/125	2CSG121130R1161	669906			0.210	1
150	1-5	CT-SM1/150	2CSG121140R1161	670001			0.210	1

From cable (max. ø 11 mm) or horizontal bar 15x5 mm (minimum distance between cables or bars = 27 mm)

60	3-3	CT-SM2/60	2CSG221080R1161	670100			0.210	1
75	3-3	CT-SM2/75	2CSG221090R1161	670209			0.210	1
80	3-3	CT-SM2/80	2CSG221100R1161	670308			0.210	1
100	1-3	CT-SM2/100	2CSG221110R1161	670407			0.210	1
120	1-5	CT-SM2/120	2CSG221120R1161	670506			0.210	1
125	1-5	CT-SM2/125	2CSG221130R1161	670605			0.210	1
150	1-5	CT-SM2/150	2CSG221140R1161	670704			0.210	1



CT-SM

2CSC400233F0201

From cable (max. \varnothing 18 mm - minimum distance between cables or bars = 45 mm)

40	3-3	CT-SM3/40	2CSG321060R1161	670803	0.320	1
50	3-4	CT-SM3/50	2CSG321070R1161	670902	0.320	1
60	3-5	CT-SM3/60	2CSG321080R1161	671008	0.320	1
75	3-5	CT-SM3/75	2CSG321090R1161	671107	0.320	1
80	3-5	CT-SM3/80	2CSG321100R1161	671206	0.320	1
100	1-5	CT-SM3/100	2CSG321110R1161	671305	0.320	1
120	1-3	CT-SM3/120	2CSG321120R1161	671404	0.320	1
125	1-3	CT-SM3/125	2CSG321130R1161	671503	0.320	1
150	0.5-5	CT-SM3/150	2CSG321140R1161	671602	0.320	1
200	0.5-5	CT-SM3/200	2CSG321150R1161	671701	0.320	1
250	0.5-10	CT-SM3/250	2CSG321160R1161	671800	0.320	1
300	0.5-10	CT-SM3/300	2CSG321170R1161	671909	0.320	1

From cable (max. \varnothing 25 mm - minimum distance between cables or bars = 45 mm)

200	0.5-5	CT-SM4/200	2CSG421150R1161	672005	0.320	1
250	0.5-6	CT-SM4/250	2CSG421160R1161	672104	0.320	1
300	0.5-6	CT-SM4/300	2CSG421170R1161	672203	0.320	1
400	0.5-10	CT-SM4/400	2CSG421180R1161	672302	0.320	1

From horizontal bar 15x5 - 20x5 - 25x5 - 25x6.5 mm or from vertical bar 15x5 - 20x5 mm (minimum distance between bars = 35 mm)

100	1-4	CT-SM5/100	2CSG521110R1161	672401	0.260	1
120	1-4	CT-SM5/120	2CSG521120R1161	672500	0.260	1
125	1-4	CT-SM5/125	2CSG521130R1161	672609	0.260	1
150	1-4	CT-SM5/150	2CSG521140R1161	672708	0.260	1
200	1-4	CT-SM5/200	2CSG521150R1161	672807	0.260	1
250	1-4	CT-SM5/250	2CSG521160R1161	672906	0.260	1
300	0.5-4	CT-SM5/300	2CSG521170R1161	673002	0.260	1

From cable (max. \varnothing 32 mm - minimum distance between cables or bars = 45 mm)

300	0.5-5	CT-SM6/300	2CSG621170R1161	673101	0.320	1
400	0.5-6	CT-SM6/400	2CSG621180R1161	673200	0.320	1
500	0.5-10	CT-SM6/500	2CSG621190R1161	673309	0.320	1
600	0.5-10	CT-SM6/600	2CSG621200R1161	673408	0.320	1

From horizontal bar 29x9.5 - 29x10.5 - 30x5 - 30x6 - 30x8 - 30x10 - 2x30x5 - 2x32x5 mm or from vertical bar 32x5 mm (minimum distance between horizontal bars = 45 mm. between vertical bars = 35 mm)

200	1-5	CT-SM7/200	2CSG731150R1161	673507	0.320	1
250	1-5	CT-SM7/250	2CSG731160R1161	673606	0.320	1
300	0.5-5	CT-SM7/300	2CSG731170R1161	673705	0.320	1
400	0.5-5	CT-SM7/400	2CSG731180R1161	673804	0.320	1
500	0.5-10	CT-SM7/500	2CSG731190R1161	673903	0.320	1
600	0.5-10	CT-SM7/600	2CSG731200R1161	674009	0.320	1



CT-SM

2CSC400223F0201

Primary rated current I _{prim}	Precision class - Rating power	Order details		Bbn 8012542	Price 1 piece	Price group	Weight 1 piece	Pack unit
A	-VA	Type code	Order code	EAN			kg	pc.
From horizontal bar 30x30 - 30x45 - 37x9.5 - 37x13 - 50x10 - 55x9.5 - 55x13 - 63x35 - 2x50x5 2x50x10 2x63x5 - 3x50x5 mm (minimum distance between horizontal bars = 70 mm)								
200	1-5	CT-SM8/200	2CSG821150R1161	674108			0.410	1
250	1-5	CT-SM8/250	2CSG821160R1161	674207			0.410	1
300	0.5-5	CT-SM8/300	2CSG821170R1161	674306			0.410	1
400	0.5-5	CT-SM8/400	2CSG821180R1161	674405			0.410	1
500	0.5-10	CT-SM8/500	2CSG821190R1161	674504			0.410	1
600	0.5-10	CT-SM8/600	2CSG821200R1161	674603			0.410	1
800	0.5-10	CT-SM8/800	2CSG821220R1161	674702			0.410	1
1000	0.5-15	CT-SM8/1000	2CSG821230R1161	674801			0.410	1
1250	0.5-15	CT-SM8/1250	2CSG821240R1161	674900			0.410	1
1500	0.5-15	CT-SM8/1500	2CSG821250R1161	675006			0.410	1

From vertical bar 2x63x5 - 3x63x5 mm (minimum distance between bars = 45 mm)

400	0.5-5	CT-SM9/400	2CSG931180R1161	675105			0.420	1
500	0.5-10	CT-SM9/500	2CSG931190R1161	675204			0.420	1
600	0.5-10	CT-SM9/600	2CSG931200R1161	675303			0.420	1
800	0.5-10	CT-SM9/800	2CSG931210R1161	675402			0.420	1
1000	0.5-15	CT-SM9/1000	2CSG931220R1161	675501			0.420	1
1250	0.5-15	CT-SM9/1250	2CSG931240R1161	675600			0.420	1
1500	0.5-15	CT-SM9/1500	2CSG931250R1161	675709			0.420	1

Protection type current transformer.../5 A

Primary rated current I _{prim}	Rating power (Accuracy class)	Order details		Bbn 8012542	Price 1 piece	Price group	Weight 1 piece	Pack unit
A	VA	Type code	Order code	EAN			kg	pc.

With wound primary, primary and secondary current on terminals

5	4 (5P5)	CTP1 5P5/5	2CSG111010R1171	675808			0.390	1
10	4 (5P5)	CTP1 5P5/10	2CSG111020R1171	675907			0.390	1
15	4 (5P5)	CTP1 5P5/15	2CSG111030R1171	676003			0.390	1
20	4 (5P5)	CTP1 5P5/20	2CSG111040R1171	676102			0.390	1
25	4 (5P5)	CTP1 5P5/25	2CSG111050R1171	676201			0.390	1
40	4 (5P5)	CTP1 5P5/40	2CSG111060R1171	676300			0.390	1

With wound primary, primary and secondary current on terminals

5	2 (5P10)	CTP1 5P10/5	2CSG121010R1171	676409			0.390	1
10	2 (5P10)	CTP1 5P10/10	2CSG121020R1171	676508			0.390	1
15	2 (5P10)	CTP1 5P10/15	2CSG121030R1171	676607			0.390	1
20	2 (5P10)	CTP1 5P10/20	2CSG121040R1171	676706			0.390	1
25	2 (5P10)	CTP1 5P10/25	2CSG121050R1171	676805			0.390	1
40	2 (5P10)	CTP1 5P10/40	2CSG121060R1171	676904			0.390	1



CTP1

2CSC400224F0201



CTP2

2CSC40025F0201



CTP5

2CSC400123F0201

With wound primary, primary current from built-in central bar 25x3 mm up to 300 A, 25x5 mm from 400 to 500 A and secondary current on terminals

50	4 (5P5)	CTP2 5P5/50	2CSG211070R1171	677000	0.390	1
60	4 (5P5)	CTP2 5P5/60	2CSG211080R1171	677109	0.390	1
80	4 (5P5)	CTP2 5P5/80	2CSG211090R1171	677208	0.390	1
100	4 (5P5)	CTP2 5P5/100	2CSG211100R1171	677307	0.390	1
150	4 (5P5)	CTP2 5P5/150	2CSG211110R1171	677406	0.390	1
200	4 (5P5)	CTP2 5P5/200	2CSG211120R1171	677505	0.390	1
250	4 (5P5)	CTP2 5P5/250	2CSG211130R1171	677604	0.390	1
300	4 (5P5)	CTP2 5P5/300	2CSG211140R1171	677703	0.390	1
400	4 (5P5)	CTP2 5P5/400	2CSG211150R1171	677802	0.390	1
500	4 (5P5)	CTP2 5P5/500	2CSG211160R1171	677901	0.390	1

With wound primary, primary current from built-in central bar 25x3 mm up to 300 A, 25x5 mm from 400 to 500 A and secondary current on terminals

50	2 (5P10)	CTP2 5P10/50	2CSG221070R1171	678007	0.390	1
60	2 (5P10)	CTP2 5P10/60	2CSG221080R1171	678106	0.390	1
80	2 (5P10)	CTP2 5P10/80	2CSG221090R1171	678205	0.390	1
100	2 (5P10)	CTP2 5P10/100	2CSG221100R1171	678304	0.390	1
150	2 (5P10)	CTP2 5P10/150	2CSG221110R1171	678403	0.390	1
200	2 (5P10)	CTP2 5P10/200	2CSG221120R1171	678502	0.390	1
250	2 (5P10)	CTP2 5P10/250	2CSG221130R1171	678601	0.390	1
300	2 (5P10)	CTP2 5P10/300	2CSG221140R1171	678700	0.390	1
400	2 (5P10)	CTP2 5P10/400	2CSG221150R1171	678809	0.390	1
500	2 (5P10)	CTP2 5P10/500	2CSG221160R1171	678908	0.390	1

For primary current from cable (max. \varnothing 30 mm) or from horizontal bar 30x30 - 40x25 - 50x20 mm, vertical 30x10 mm

250	4 (5P5)	CTP5 5P5/250	2CSG311130R1171	679004	0.430	1
300	4 (5P5)	CTP5 5P5/300	2CSG311140R1171	679103	0.430	1
400	4 (5P5)	CTP5 5P5/400	2CSG311150R1171	679202	0.430	1
500	4 (5P5)	CTP5 5P5/500	2CSG311160R1171	679301	0.430	1
600	4 (5P5)	CTP5 5P5/600	2CSG311170R1171	679400	0.430	1

For primary current from cable (max. \varnothing 30 mm) or from horizontal bar 30x30 - 40x25 - 50x20 mm, vertical 30x10 mm

800	4 (5P5)	CTP5 5P5/800	2CSG311180R1171	679509	0.430	1
1000	4 (5P5)	CTP5 5P5/1000	2CSG311190R1171	679608	0.430	1
1200	6 (5P5)	CTP5 5P5/1200	2CSG311200R1171	679707	0.430	1
1500	8 (5P5)	CTP5 5P5/1500	2CSG311220R1171	679806	0.430	1

For primary current from cable (max. \varnothing 30 mm) or from horizontal bar 30x30 - 40x25 - 50x20 mm, vertical 30x10 mm

250	2 (5P10)	CTP5 5P10/250	2CSG321130R1171	679905	0.430	1
300	2 (5P10)	CTP5 5P10/300	2CSG321140R1171	680000	0.430	1
400	2 (5P10)	CTP5 5P10/400	2CSG321150R1171	680109	0.430	1
500	2 (5P10)	CTP5 5P10/500	2CSG321160R1171	680208	0.430	1
600	2 (5P10)	CTP5 5P10/600	2CSG321170R1171	680307	0.430	1
800	2 (5P10)	CTP5 5P10/800	2CSG321180R1171	680406	0.430	1
1000	2 (5P10)	CTP5 5P10/1000	2CSG321190R1171	680505	0.430	1
1200	3 (5P10)	CTP5 5P10/1200	2CSG321200R1171	680604	0.430	1
1500	4 (5P10)	CTP5 5P10/1500	2CSG321220R1171	680703	0.430	1



CTP6

2CSC400124F0201

Primary rated current I _{prim}	Rating power (Accuracy class)	Order details	Bbn 8012542	Price 1 piece	Price group	Weight 1 piece	Pack unit
A	VA	Type code	Order code	EAN		kg	pc.
For primary current from cable (max. ø 50 mm) or from horizontal bar 50x20 - 60x20 mm							
250	6 (5P5)	CTP6 5P5/250	2CSG411130R1171	680802		0.460	1
300	6 (5P5)	CTP6 5P5/300	2CSG411140R1171	680901		0.460	1
400	5 (5P5)	CTP6 5P5/400	2CSG411150R1171	681007		0.460	1
500	5 (5P5)	CTP6 5P5/500	2CSG411160R1171	681106		0.460	1
600	5 (5P5)	CTP6 5P5/600	2CSG411170R1171	681205		0.460	1
800	15 (5P5)	CTP6 5P5/800	2CSG411180R1171	681304		0.460	1
1000	20 (5P5)	CTP6 5P5/1000	2CSG411190R1171	681403		0.460	1
1200	20 (5P5)	CTP6 5P5/1200	2CSG411200R1171	681502		0.460	1
1500	30 (5P5)	CTP6 5P5/1500	2CSG411220R1171	681601		0.460	1

For primary current from cable (max. ø 50 mm) or from horizontal bar 50x20 - 60x20 mm

250	2 (5P10)	CTP6 5P10/250	2CSG421130R1171	681700		0.460	1
300	3 (5P10)	CTP6 5P10/300	2CSG421140R1171	681809		0.460	1
400	4 (5P10)	CTP6 5P10/400	2CSG421150R1171	681908		0.460	1
500	4 (5P10)	CTP6 5P10/500	2CSG421160R1171	682004		0.460	1
600	4 (5P10)	CTP6 5P10/600	2CSG421170R1171	682103		0.460	1
800	5 (5P10)	CTP6 5P10/800	2CSG421180R1171	682202		0.460	1
1000	6 (5P10)	CTP6 5P10/1000	2CSG421190R1171	682301		0.460	1
1200	6 (5P10)	CTP6 5P10/1200	2CSG421200R1171	682400		0.460	1
1500	10 (5P10)	CTP6 5P10/1500	2CSG421220R1171	682509		0.460	1

For primary current from two cables (max. ø 30 mm each) or from horizontal bar 60x30 - 80x30 mm

300	5 (5P5)	CTP8 5P5/300	2CSG511140R1171	682608		0.500	1
400	6 (5P5)	CTP8 5P5/400	2CSG511150R1171	682707		0.500	1
500	15 (5P5)	CTP8 5P5/500	2CSG511160R1171	682806		0.500	1
600	20 (5P5)	CTP8 5P5/600	2CSG511170R1171	682905		0.500	1
800	20 (5P5)	CTP8 5P5/800	2CSG511180R1171	683001		0.500	1
1000	20 (5P5)	CTP8 5P5/1000	2CSG511190R1171	683100		0.500	1
1200	30 (5P5)	CTP8 5P5/1200	2CSG511200R1171	683209		0.500	1
1500	20 (5P5)	CTP8 5P5/1500	2CSG511220R1171	683308		0.500	1
2000	12 (5P5)	CTP8 5P5/2000	2CSG511230R1171	683407		0.500	1
2500	15 (5P5)	CTP8 5P5/2500	2CSG511240R1171	683506		0.500	1

For primary current from two cables (max. ø 30 mm each) or from horizontal bar 60x30 - 80x30 mm

300	3 (5P10)	CTP8 5P10/300	2CSG521140R1171	683605		0.500	1
400	3 (5P10)	CTP8 5P10/400	2CSG521150R1171	683704		0.500	1
500	8 (5P10)	CTP8 5P10/500	2CSG521160R1171	683803		0.500	1
600	8 (5P10)	CTP8 5P10/600	2CSG521170R1171	683902		0.500	1
800	10 (5P10)	CTP8 5P10/800	2CSG521180R1171	684008		0.500	1
1000	10 (5P10)	CTP8 5P10/1000	2CSG521190R1171	684107		0.500	1
1200	15 (5P10)	CTP8 5P10/1200	2CSG521200R1171	684206		0.500	1
1500	6 (5P10)	CTP8 5P10/1500	2CSG521220R1171	684305		0.500	1
2000	6 (5P10)	CTP8 5P10/2000	2CSG521230R1171	684404		0.500	1
2500	8 (5P10)	CTP8 5P10/2500	2CSG521240R1171	684503		0.500	1



CTP8

2CSC400125F0201



For primary current from two cables (max. \varnothing 30 mm each) or from horizontal bar 60x30 - 80x30 mm

300	1.5 (5P15)	CTP8 5P15/300	2CSG531140R1171	684602	0.500	1
400	1.5 (5P15)	CTP8 5P15/400	2CSG531150R1171	684701	0.500	1
500	4 (5P15)	CTP8 5P15/500	2CSG531160R1171	684800	0.500	1
600	4 (5P15)	CTP8 5P15/600	2CSG531170R1171	684909	0.500	1
800	6 (5P15)	CTP8 5P15/800	2CSG531180R1171	685005	0.500	1
1000	5 (5P15)	CTP8 5P15/1000	2CSG531190R1171	685104	0.500	1
1200	6 (5P15)	CTP8 5P15/1200	2CSG531200R1171	685203	0.500	1
1500	2 (5P15)	CTP8 5P15/1500	2CSG531220R1171	685302	0.500	1
2000	5 (5P15)	CTP8 5P15/2000	2CSG531230R1171	685401	0.500	1
2500	6 (5P15)	CTP8 5P15/2500	2CSG531240R1171	685500	0.500	1

For primary current from two cables (max. \varnothing 30 mm each) or from horizontal bar 60x30 - 80x30 mm

300	1 (5P20)	CTP8 5P20/300	2CSG541140R1171	685609	0.500	1
400	1 (5P20)	CTP8 5P20/400	2CSG541150R1171	685708	0.500	1
500	2 (5P20)	CTP8 5P20/500	2CSG541160R1171	685807	0.500	1
600	2 (5P20)	CTP8 5P20/600	2CSG541170R1171	685906	0.500	1
800	3 (5P20)	CTP8 5P20/800	2CSG541180R1171	686002	0.500	1
1000	2 (5P20)	CTP8 5P20/1000	2CSG541190R1171	686101	0.500	1
1200	3 (5P20)	CTP8 5P20/1200	2CSG541200R1171	686200	0.500	1
1500	1 (5P20)	CTP8 5P20/1500	2CSG541220R1171	686309	0.500	1
2000	3 (5P20)	CTP8 5P20/2000	2CSG541230R1171	686408	0.500	1
2500	4 (5P20)	CTP8 5P20/2500	2CSG541240R1171	686507	0.500	1

For primary current from two cables (max. \varnothing 50 mm each) or from horizontal bar 80x50 - 100x50 - 125x50 mm

400	8 (5P5)	CTP12 5P5/400	2CSG611150R1171	686606	0.390	1
500	8 (5P5)	CTP12 5P5/500	2CSG611160R1171	686705	0.390	1
600	8 (5P5)	CTP12 5P5/600	2CSG611170R1171	686804	0.390	1
800	12 (5P5)	CTP12 5P5/800	2CSG611180R1171	686903	0.390	1
1000	15 (5P5)	CTP12 5P5/1000	2CSG611190R1171	687009	0.390	1
1200	20 (5P5)	CTP12 5P5/1200	2CSG611200R1171	687108	0.390	1
1500	20 (5P5)	CTP12 5P5/1500	2CSG611220R1171	687207	0.390	1
2000	25 (5P5)	CTP12 5P5/2000	2CSG611230R1171	687306	0.390	1
2500	30 (5P5)	CTP12 5P5/2500	2CSG611240R1171	687405	0.390	1
3000	40 (5P5)	CTP12 5P5/3000	2CSG611250R1171	687504	0.390	1
4000	50 (5P5)	CTP12 5P5/4000	2CSG611260R1171	687603	0.390	1

For primary current from two cables (max. \varnothing 50 mm each) or from horizontal bar 80x50 - 100x50 - 125x50 mm

400	4 (5P10)	CTP12 5P10/400	2CSG621150R1171	687702	0.390	1
500	4 (5P10)	CTP12 5P10/500	2CSG621160R1171	687801	0.390	1
600	4 (5P10)	CTP12 5P10/600	2CSG621170R1171	687900	0.390	1
800	6 (5P10)	CTP12 5P10/800	2CSG621180R1171	688006	0.390	1
1000	8 (5P10)	CTP12 5P10/1000	2CSG621190R1171	688105	0.390	1
1200	10 (5P10)	CTP12 5P10/1200	2CSG621200R1171	688204	0.390	1
1500	10 (5P10)	CTP12 5P10/1500	2CSG621220R1171	688303	0.390	1
2000	12 (5P10)	CTP12 5P10/2000	2CSG621230R1171	688402	0.390	1
2500	15 (5P10)	CTP12 5P10/2500	2CSG621240R1171	688501	0.390	1
3000	20 (5P10)	CTP12 5P10/3000	2CSG621250R1171	688600	0.390	1
4000	25 (5P10)	CTP12 5P10/4000	2CSG621260R1171	688709	0.390	1

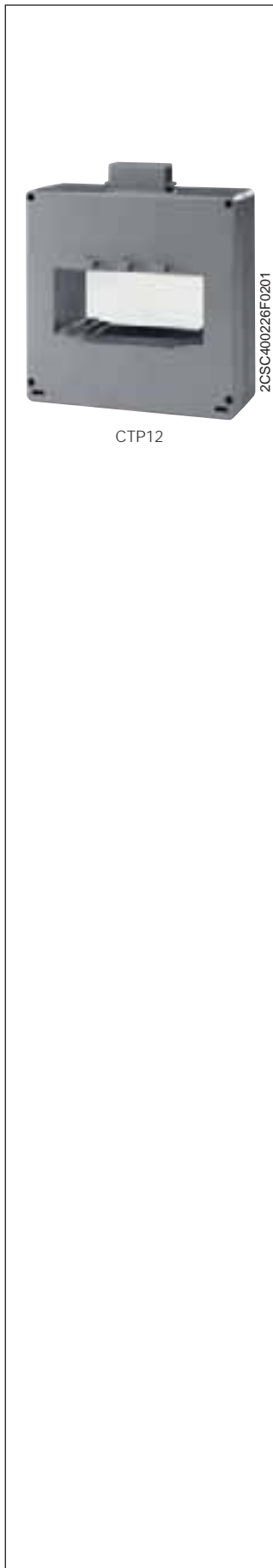

Primary rated current I _{prim}	Rating power (Accuracy class)	Order details		Bbn 8012542	Price 1 piece	Price group	Weight 1 piece	Pack unit
A	VA	Type code	Order code	EAN			kg	pc.

For primary current from two cables (max. ø 50 mm each) or from horizontal bar 80x50 - 100x50 - 125x50 mm

400	3 (5P15)	CTP12 5P15/400	2CSG631150R1171	688808			0.390	1
500	3 (5P15)	CTP12 5P15/500	2CSG631160R1171	688907			0.390	1
600	3 (5P15)	CTP12 5P15/600	2CSG631170R1171	689003			0.390	1
800	4 (5P15)	CTP12 5P15/800	2CSG631180R1171	689102			0.390	1
1000	6 (5P15)	CTP12 5P15/1000	2CSG631190R1171	689201			0.390	1
1200	6 (5P15)	CTP12 5P15/1200	2CSG631200R1171	689300			0.390	1
1500	6 (5P15)	CTP12 5P15/1500	2CSG631220R1171	689409			0.390	1
2000	8 (5P15)	CTP12 5P15/2000	2CSG631230R1171	689508			0.390	1
2500	10 (5P15)	CTP12 5P15/2500	2CSG631240R1171	689607			0.390	1
3000	15 (5P15)	CTP12 5P15/3000	2CSG631250R1171	689706			0.390	1
4000	15 (5P15)	CTP12 5P15/4000	2CSG631260R1171	689805			0.390	1

For primary current from two cables (max. ø 50 mm each) or from horizontal bar 80x50 - 100x50 - 125x50 mm

400	2 (5P20)	CTP12 5P20/400	2CSG641150R1171	689904			0.390	1
500	2 (5P20)	CTP12 5P20/500	2CSG641160R1171	690009			0.390	1
600	2 (5P20)	CTP12 5P20/600	2CSG641170R1171	690108			0.390	1
800	3 (5P20)	CTP12 5P20/800	2CSG641180R1171	690207			0.390	1
1000	4 (5P20)	CTP12 5P20/1000	2CSG641190R1171	690306			0.390	1
1200	5 (5P20)	CTP12 5P20/1200	2CSG641200R1171	690405			0.390	1
1500	5 (5P20)	CTP12 5P20/1500	2CSG641220R1171	690504			0.390	1
2000	6 (5P20)	CTP12 5P20/2000	2CSG641230R1171	690603			0.390	1
2500	8 (5P20)	CTP12 5P20/2500	2CSG641240R1171	690702			0.390	1
3000	10 (5P20)	CTP12 5P20/3000	2CSG641250R1171	690801			0.390	1
4000	12 (5P20)	CTP12 5P20/4000	2CSG641260R1171	690900			0.390	1



Summing current transformers

They are used for calculating the vector sum of currents of two or more lines of a single voltage system.

Installation on DIN rail.

The insulation reference voltage is 0.72 kV – 3kV.

Summing current transformers.../5 A (6 DIN modules)

Type	Power VA	Order details Type code	Order code	Bbn 8012542 EAN	Price 1 piece	Price group	Weight 1 piece kg	Pack unit pc.
5+5=5A	6	CTSM-5-5	2CSM101010R1181	610403			0.300	1
5+5+5=5A	6	CTSM-5-5-5	2CSM101020R1181	610502			0.300	1
5+5+5+5=5A	6	CTSM-5-5-5-5	2CSM101030R1181	610601			0.300	1



Voltage transformers

They are used for transforming primary voltages up to 600 V into secondary voltages of.../100 V max. for indirect supply of analogue as well as digital measurement instruments.

Voltage transformers with self-extinguishing plastic housing, precision class 1

Primary/ secondary voltage	Power	Order details		Bbn 8012542	Price 1 piece	Price group	Weight 1 piece	Pack unit
V/V	VA	Type code	Order code	EAN			kg	pc.
100/100	3	TV-100/100	2CSG112010R5021	746805			1.000	1
110/100	6	TV-110/100	2CSG112030R5021	610700			1.000	1
115/100	3	TV-115/100	2CSG112050R5021	746904			1.000	1
230/100	6	TV-230/100	2CSG112070R5021	610809			1.000	1
380/100	6	TV-380/100	2CSG112090R5021	610908			1.000	1
400/100	6	TV-400/100	2CSG112110R5021	611004			1.000	1
440/100	3	TV-440/100	2CSG112130R5021	747000			1.000	1
500/100	6	TV-500/100	2CSG112150R5021	611103			1.000	1
100/100- $\sqrt{3}$	1.5	TV-100R3/100	2CSG111020R5021	747604			1.000	1
110/100- $\sqrt{3}$	1.5	TV-110R3/100	2CSG111040R5021	747703			1.000	1
115/100- $\sqrt{3}$	1.5	TV-115R3/100	2CSG111060R5021	747802			1.000	1
230/100- $\sqrt{3}$	1.5	TV-230R3/100	2CSG111080R5021	747901			1.000	1
380/100- $\sqrt{3}$	1.5	TV-380R3/100	2CSG111100R5021	748007			1.000	1
400/100- $\sqrt{3}$	1.5	TV-400R3/100	2CSG111120R5021	748106			1.000	1
440/100- $\sqrt{3}$	1.5	TV-440R3/100	2CSG111140R5021	748205			1.000	1
500/100- $\sqrt{3}$	1.5	TV-500R3/100	2CSG111160R5021	748304			1.000	1



2CSC400127F0201

Voltage transformers with metallic housing, precision class 0.5

Primary/ secondary voltage	Power	Order details		Bbn 8012542	Price 1 piece	Price group	Weight 1 piece	Pack unit
V/V	VA	Type code	Order code	EAN			kg	pc.
100/100	10	TV2-100/100	2CSG324010R5021	729808			2.100	1
110/100	10	TV2-110/100	2CSG324030R5021	729907			2.100	1
115/100	10	TV2-115/100	2CSG324050R5021	730002			2.100	1
230/100	10	TV2-230/100	2CSG324070R5021	730101			2.100	1
380/100	10	TV2-380/100	2CSG324090R5021	730200			2.100	1
400/100	10	TV2-400/100	2CSG324110R5021	730309			2.100	1
440/100	10	TV2-440/100	2CSG324130R5021	730408			2.100	1
500/100	10	TV2-500/100	2CSG324150R5021	730507			2.100	1
600/100	10	TV2-600/100	2CSG324170R5021	730606			2.100	1
100/100-√3	5	TV2-100R3/100	2CSG323020R5021	730705			2.100	1
110/100-√3	5	TV2-110R3/100	2CSG323040R5021	730804			2.100	1
115/100-√3	5	TV2-115R3/100	2CSG323060R5021	730903			2.100	1
230/100-√3	5	TV2-230R3/100	2CSG323080R5021	731009			2.100	1
380/100-√3	5	TV2-380R3/100	2CSG323100R5021	731108			2.100	1
400/100-√3	5	TV2-400R3/100	2CSG323120R5021	731207			2.100	1
440/100-√3	5	TV2-440R3/100	2CSG323140R5021	731306			2.100	1
500/100-√3	5	TV2-500R3/100	2CSG323160R5021	731405			2.100	1
600/100-√3	5	TV2-600R3/100	2CSG323180R5021	731504			2.100	1
100/100	20	TV3-100/100	2CSG426010R5021	731603			2.200	1
110/100	20	TV3-110/100	2CSG426030R5021	731702			2.200	1
115/100	20	TV3-115/100	2CSG426050R5021	731801			2.200	1
230/100	20	TV3-230/100	2CSG426070R5021	731900			2.200	1
380/100	20	TV3-380/100	2CSG426090R5021	732006			2.200	1
400/100	20	TV3-400/100	2CSG426110R5021	732105			2.200	1
440/100	20	TV3-440/100	2CSG426130R5021	732204			2.200	1
500/100	20	TV3-500/100	2CSG426150R5021	732303			2.200	1
600/100	20	TV3-600/100	2CSG426170R5021	732402			2.200	1
100/100-√3	10	TV3-100R3/100	2CSG424020R5021	732501			2.200	1
110/100-√3	10	TV3-110R3/100	2CSG424040R5021	732600			2.200	1
115/100-√3	10	TV3-115R3/100	2CSG424060R5021	732709			2.200	1
230/100-√3	10	TV3-230R3/100	2CSG424080R5021	732808			2.200	1
380/100-√3	10	TV3-380R3/100	2CSG424100R5021	732907			2.200	1
400/100-√3	10	TV3-400R3/100	2CSG424120R5021	733003			2.200	1
440/100-√3	10	TV3-440R3/100	2CSG424140R5021	733102			2.200	1
500/100-√3	10	TV3-500R3/100	2CSG424160R5021	733201			2.200	1
600/100-√3	10	TV3-600R3/100	2CSG424180R5021	733300			2.200	1
100/100	50	TV4-100/100	2CSG528010R5021	733409			2.400	1
110/100	50	TV4-110/100	2CSG528030R5021	733508			2.400	1
115/100	50	TV4-115/100	2CSG528050R5021	733607			2.400	1
230/100	50	TV4-230/100	2CSG528070R5021	733706			2.400	1
380/100	50	TV4-380/100	2CSG528090R5021	733805			2.400	1
400/100	50	TV4-400/100	2CSG528110R5021	733904			2.400	1
440/100	50	TV4-440/100	2CSG528130R5021	734000			2.400	1
500/100	50	TV4-500/100	2CSG528150R5021	734109			2.400	1
600/100	50	TV4-600/100	2CSG528170R5021	734208			2.400	1
100/100-√3	25	TV4-100R3/100	2CSG527020R5021	734307			2.400	1
110/100-√3	25	TV4-110R3/100	2CSG527040R5021	734406			2.400	1
115/100-√3	25	TV4-115R3/100	2CSG527060R5021	734505			2.400	1
230/100-√3	25	TV4-230R3/100	2CSG527080R5021	734604			2.400	1
380/100-√3	25	TV4-380R3/100	2CSG527100R5021	734703			2.400	1
400/100-√3	25	TV4-400R3/100	2CSG527120R5021	734802			2.400	1
440/100-√3	25	TV4-440R3/100	2CSG527140R5021	734901			2.400	1
500/100-√3	25	TV4-500R3/100	2CSG527160R5021	735007			2.400	1
600/100-√3	25	TV4-600R3/100	2CSG527180R5021	735106			2.400	1

100/100	100	TV5-100/100	2CSG629010R5021	735205	2.600	1
110/100	100	TV5-110/100	2CSG629030R5021	735304	2.600	1
115/100	100	TV5-115/100	2CSG629050R5021	735403	2.600	1
230/100	100	TV5-230/100	2CSG629070R5021	735502	2.600	1
380/100	100	TV5-380/100	2CSG629090R5021	735601	2.600	1
400/100	100	TV5-400/100	2CSG629110R5021	735700	2.600	1
440/100	100	TV5-440/100	2CSG629130R5021	735809	2.600	1
500/100	100	TV5-500/100	2CSG629150R5021	735908	2.600	1
600/100	100	TV5-600/100	2CSG629170R5021	736004	2.600	1
100/100- $\sqrt{3}$	50	TV5-100R3/100	2CSG628020R5021	736103	2.600	1
110/100- $\sqrt{3}$	50	TV5-110R3/100	2CSG628040R5021	736202	2.600	1
115/100- $\sqrt{3}$	50	TV5-115R3/100	2CSG628060R5021	736301	2.600	1
230/100- $\sqrt{3}$	50	TV5-230R3/100	2CSG628080R5021	736400	2.600	1
380/100- $\sqrt{3}$	50	TV5-380R3/100	2CSG628100R5021	736509	2.600	1
400/100- $\sqrt{3}$	50	TV5-400R3/100	2CSG628120R5021	736608	2.600	1
440/100- $\sqrt{3}$	50	TV5-440R3/100	2CSG628140R5021	736707	2.600	1
500/100- $\sqrt{3}$	50	TV5-500R3/100	2CSG628160R5021	736806	2.600	1
600/100- $\sqrt{3}$	50	TV5-600R3/100	2CSG628180R5021	736905	2.600	1

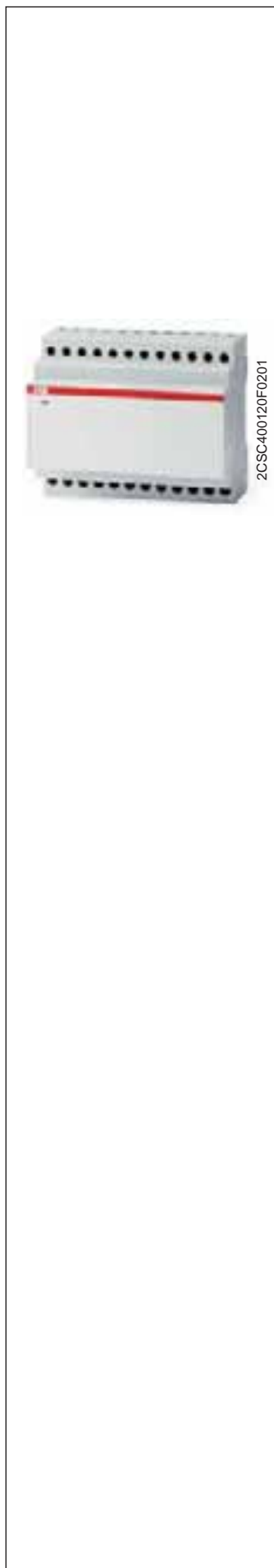

Current and voltage converters

They produce an output signal in direct current independent from the load that is directly proportional to the input current or voltage signal.

Their electronic circuit guarantees high reliability and accuracy of operation, extension of the measurement field, resistance to temperature changes and to vibrations, limited power absorption from the circuit to be measured.

Thanks to their centralized data acquisition speed, even at high distances, and thanks to the availability of different output types (that can be selected by means of the adjusting minidips) they are appropriate for plants requiring specific attention to production, distribution and use of electric energy.

Current converters with a.c. supply. with inputs 1 and 5 V a.c. and selectable outputs 1-5-10 V d.c. and 1-5-10-20-4...20 mA d.c.

Supply	Modules	Order details	Bbn	Price	Price	Weight	Pack
			8012542	1 piece	group	1 piece	unit
VAC		Type code	EAN			kg	pc.
24	6	CONV-I-1-24CA	2CSG313000R5031	740902		0.800	1
110	6	CONV-I-1-110CA	2CSG353000R5031	741107		0.800	1
230	6	CONV-I-1-230CA	2CSG373000R5031	741206		0.800	1
24	6	CONV-I-2-24CA	2CSG414000R5031	741305		0.800	1
110	6	CONV-I-2-110CA	2CSG454000R5031	741503		0.800	1
230	6	CONV-I-2-230CA	2CSG474000R5031	741602		0.800	1

Current converters with d.c. supply with inputs 1 and 5 V a.c. and selectable outputs 1-5-10 V d.c. and 1-5-10-20-4...20 mA d.c.

Supply	Modules	Order details	Bbn	Price	Price	Weight	Pack
			8012542	1 piece	group	1 piece	unit
VDC		Type code	EAN			kg	pc.
24	6	CONV-I-1-24CC	2CSG323000R5031	741701		0.800	1
110	6	CONV-I-1-110CC	2CSG363000R5031	741909		0.800	1
24	6	CONV-I-2-24CC	2CSG424000R5031	742005		0.800	1
110	6	CONV-I-2-110CC	2CSG464000R5031	742203		0.800	1

Current converters with a.c. supply. with inputs 120-300-500 V a.c. and selectable outputs 1-5-10 V d.c. and 1-5-10-20-4...20 mA d.c.

Supply	Modules	Order details	Bbn	Price	Price	Weight	Pack
			8012542	1 piece	group	1 piece	unit
VAC		Type code	EAN			kg	pc.
24	6	CONV-V-1-24CA	2CSG111000R5031	739500		0.800	1
110	6	CONV-V-1-110CA	2CSG151000R5031	739708		0.800	1
230	6	CONV-V-1-230CA	2CSG171000R5031	739807		0.800	1
24	6	CONV-V-2-24CA	2CSG212000R5031	739906		0.800	1
110	6	CONV-V-2-110CA	2CSG252000R5031	740100		0.800	1
230	6	CONV-V-2-230CA	2CSG272000R5031	740209		0.800	1

Current converters with d.c. supply with inputs 120-300-500 V a.c. and selectable outputs 1-5-10 V d.c. and 1-5-10-20-4...20 mA d.c.

Supply	Modules	Order details	Bbn	Price	Price	Weight	Pack
			8012542	1 piece	group	1 piece	unit
VDC		Type code	EAN			kg	pc.
24	6	CONV-V-1-24CC	2CSG121000R5031	740308		0.800	1
48	6	CONV-V-1-48CC	2CSG141000R5031	740407		0.800	1
110	6	CONV-V-1-110CC	2CSG161000R5031	740506		0.800	1
24	6	CONV-V-2-24CC	2CSG222000R5031	740605		0.800	1
48	6	CONV-V-2-48CC	2CSG242000R5031	740704		0.800	1
110	6	CONV-V-2-110CC	2CSG262000R5031	740803		0.800	1

Transducers for power factor meters

They are necessary for the indirect insertion of analogue power factor meters. They operate with a 230 V or 400 V supply and they are equipped with an electronic programming pushbutton for the selection of the more suitable output out of the eight available outputs (1, 5, 10 V d.c. and 1, 5, 10, 20, 4/20 mA d.c.). They have a galvanic type separation between inputs and outputs.



2CSC400120F0201

Phase	Description	Order details	Bbn	Price	Price group	Weight	Pack unit
		Type code	Order code	8012542	1 piece	1 piece	pc.
			EAN			kg	

Transducers for power factor meters 230/440 VAC supply

1	(2 wires)	CNV-C-1	2CSM310000R1131	600206		0.400	1
3	balanced without neutral (3 wires)	CNV-C-2	2CSM320000R1131	600305		0.400	1



Shunts

Shunts have 60 mV and 150 mV voltage and must be used with a maximum load of 0.25 Ω in combination with measurement instruments in d.c.

For an appropriate operation:

- both horizontal and vertical mounting are possible (the horizontal position enables a greater heat consumption)
- the faying surface must be completely used and clean; cover with specific grease after the connection
- screws and bolts must be perfectly tight
- shunts must be sufficiently ventilated; as they are not insulated, it is a good rule to protect them against accidental contacts.

Rated current A	Order details Type code	Order code	Bbn 8012542 EAN	Price 1 piece	Price group	Weight 1 piece kg	Pack unit pc.
--------------------	----------------------------	------------	-----------------------	------------------	----------------	-------------------------	---------------------

60 mV shunts

5	SNT 1/5	2CSM100010R1121	047605			1.300	1
6	SNT 1/6	2CSM100020R1121	047704			1.800	1
10	SNT 1/10	2CSM100030R1121	047803			1.800	1
15	SNT 1/15	2CSM100040R1121	047902			1.800	1
20	SNT 1/20	2CSM100050R1121	048008			1.800	1
25	SNT 1/25	2CSM100060R1121	048107			1.800	1
30	SNT 1/30	2CSM100070R1121	048206			1.300	1
40	SNT 1/40	2CSM100080R1121	048305			1.300	1
50	SNT 1/50	2CSM100090R1121	048404			2.200	1
60	SNT 1/60	2CSM100100R1121	048503			2.200	1
80	SNT 1/80	2CSM100110R1121	048602			1.300	1
100	SNT 1/100	2CSM100120R1121	048701			1.300	1
150	SNT 1/150	2CSM100130R1121	048800			1.300	1
200	SNT 1/200	2CSM100140R1121	048909			1.300	1
250	SNT 1/250	2CSM100150R1121	049005			1.900	1
400	SNT 1/400	2CSM100160R1121	049104			1.900	1
500	SNT 1/500	2CSM100170R1121	049203			1.900	1
600	SNT 1/600	2CSM100180R1121	049302			1.900	1
800	SNT 1/800	2CSM100190R1121	049401			2.200	1
1000	SNT 1/1000	2CSM100200R1121	049500			2.000	1
1500	SNT 1/1500	2CSM100210R1121	049609			2.200	1
2000	SNT 1/2000	2CSM100220R1121	049708			2.200	1
2500	SNT 1/2500	2CSM100230R1121	049807			2.200	1
4000	SNT 1/4000	2CSM100240R1121	747109			2.200	1
6000	SNT 1/6000	2CSM100250R1121	747208			2.300	1

Technical features

Voltage	[mV]	60/150
Current rating	[A]	from 5 to 2500 (on request up to 8000)
Accuracy class		0.5 (from 10 to 30 °C)
Max. load	[]	0.25
Overload for 5 sec.		from 10 to 500 A : 1xIn from 600 to 2000 A: 5xIn at 2500A: 2xIn

150 mV shunts

5	SNT1 1/5	2CSM200010R1121	737001	1.800	1
6	SNT1 1/6	2CSM200020R1121	737100	1.800	1
10	SNT1 1/10	2CSM200030R1121	737209	1.800	1
15	SNT1 1/15	2CSM200040R1121	737308	1.800	1
20	SNT1 1/20	2CSM200050R1121	737407	1.800	1
25	SNT1 1/25	2CSM200060R1121	737506	1.800	1
30	SNT1 1/30	2CSM200070R1121	737605	3.000	1
40	SNT1 1/40	2CSM200080R1121	737704	3.000	1
50	SNT1 1/50	2CSM200090R1121	737803	3.000	1
60	SNT1 1/60	2CSM200100R1121	737902	1.800	1
80	SNT1 1/80	2CSM200110R1121	738008	3.000	1
100	SNT1 1/100	2CSM200120R1121	738107	3.000	1
150	SNT1 1/150	2CSM200130R1121	738206	3.000	1
200	SNT1 1/200	2CSM200140R1121	738305	3.600	1
250	SNT1 1/250	2CSM200150R1121	738404	3.600	1
400	SNT1 1/400	2CSM200160R1121	738503	3.600	1
500	SNT1 1/500	2CSM200170R1121	738602	3.600	1
600	SNT1 1/600	2CSM200180R1121	738701	3.600	1
800	SNT1 1/800	2CSM200190R1121	738800	3.800	1
1000	SNT1 1/1000	2CSM200200R1121	738909	3.800	1

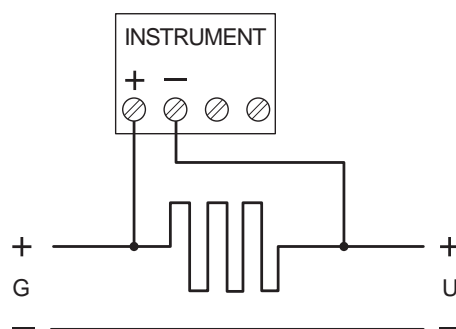



E 233 electro-mechanical hour counters

Hour counters are used to record operating times as well as to determine idle times and off times of industrial machinery and plant, for commercial purposes or in domestic installations. No reset functionality.

Rated voltage	Order details		Bbn	Price	Price	Weight	Pack
	Type code	Order code	4012233	1 piece	group	1 piece	unit
			EAN			kg	pc.
AC 230 V/50 Hz	E 233-230	2CDE100000R1601	63000 4			0.05	10
AC 24 V/50 Hz	E 233-24	2CDE400000R1601	63010 3			0.05	10
DC 12 V ... 48 V	E 233-12/48	2CDE300010R1601	63020 2			0.05	10
AC 240 V/60 Hz	E 233-240/60 Hz*	2CDE100021R1601	36590 1 ①			0.05	10
AC 120 V/60 Hz	E 233-120/60 Hz*	2CDE600021R1601	36600 7 ①			0.05	10
AC 24 V/60 Hz	E 233- 24/60 Hz*	2CDE400021R1601	36610 6 ①			0.05	10

Other rated voltages upon request.

① Bbn No. 40 16779

* U_L approval

Wiring diagram

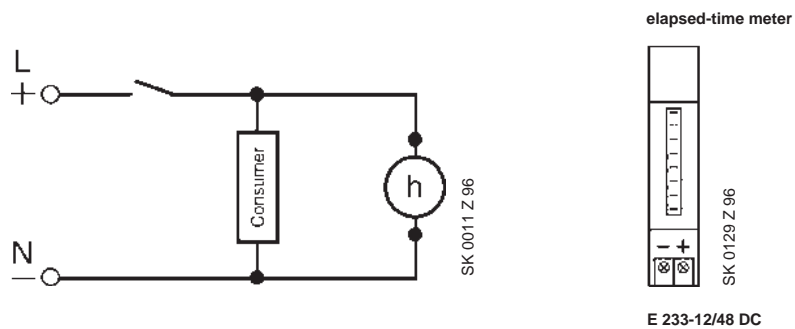

Technical features

	AC equipment	DC equipment
Rated voltage	50 Hz: 24 V, 230 V 60 Hz: 24 V, 120 V, 240 V*	DC 12 V ... 48 V
Voltage tolerance	+ 6% – 10 %	± 10 %
Power consumption	1.5 VA	ca. 20 mW (at 12 V DC)
Ambient temperature	– 15 °C/5 °F... + 50 °C/122 °F	– 10 °C/14 °F ... + 50 °C/122 °F
Counting capacity	100 000 h	100 000 h
Precision class	0.01 h	0.1 h
Operation display	fast running	LED blinking
Protection against electric shock	according to DIN VDE 0106 Part 100 (BGV A2)	according to DIN VDE 0106 Part 100 (BGV A2)
Terminal size	up to 10 mm ²	up to 10 mm ²

* U_L approval



HMT electro-mechanical hour counters

Equipped with 7-digit indicator (99.999,99) and available in two modules. They cannot be reset.

Rated voltage V AC	Order details Type code	Order code	Bbn 8012542 EAN	Price 1 piece	Price group	Weight 1 piece kg	Pack unit pc.
24	HMT 1/24	2CSM111000R1601	030300			0.200	6
110	HMT 1/110	2CSM121000R1601	030409			0.200	6
220	HMT 1/220	2CSM131000R1601	030508			0.200	6
230	HMT 11	2CSM133000R1601	030607			0.200	1

Wiring diagram

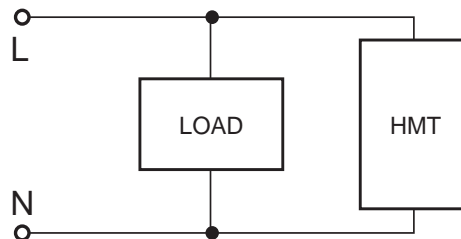

0EPM0071

Technical features

Rated voltage Un	[V]	a.c. 24 a.c. 110 a.c. 230 d.c. 12...48
Displayed digits (in hours)	[n°]	99999.9 (for HMT1 and HMT11)
Accuracy class	[%]	0.5
Frequency	[Hz]	50
Power consumption	[W]	1.1...2.2
Modules	[n°]	2



In compliance with IEC 60364 Standard, it is necessary to insulate network electric circuits using insulation transformers in installations intended for environments with special needs. Insulation transformers protect from indirect contacts without breaking the circuit on the first fault to earth.

Isoltester-DIG

The new Isoltester-DIG distinguish themselves for the superiority and the excellence of their constructive and technical features. The way they sense the insulation status of the network is based on a technology on the van in comparison to the traditional insulation tester.

Function	Order details		Bbn	Price	Price	Weight	Packing
	Type code	Order code	8012542	1 piece	group	1 piece	unit
			EAN			kg	pc.
Measuring and control (resistance and impedance + 2 temp + I _{max}) in insulated networks 230 VAC	ISOLTESTER-DIG-RZ	2CSM244000R1501	884507			0.500	1
Measuring and control (resistance, capacity and impedance + 2 temp + I _{max} + RS485) in insulated networks 230 and 400 VAC/VDC	ISOLTESTER-DIG-PLUS	2CSM341000R1501	884606			0.500	1

Functioning of the frontal operators

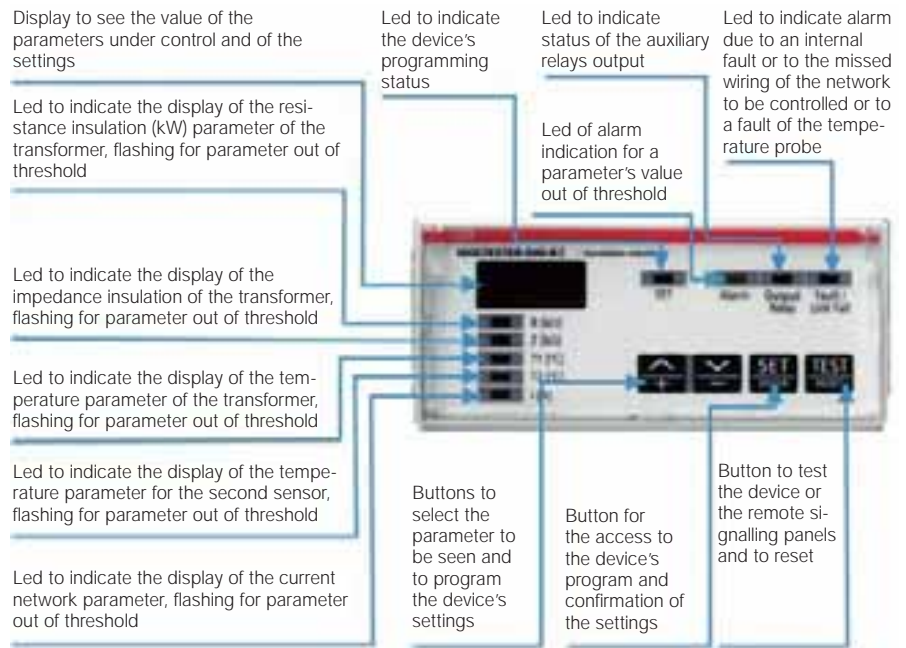

Technical features

	ISOLTESTER-DIG-PLUS	ISOLTESTER-DIG-RZ
Rated	110 - 230 V/50-60 Hz	110 - 230 V/50-60 Hz
Network voltage to be controlled	24÷400 VAC/VDC	24÷230 VAC/VDC
Voltage max. measure	24 V	24 V
Current max. measure	1 mA	1 mA
Insulation voltage	2.5 kV/60 sec.	2.5 kV/60 sec.
Type of control's signal	Codified composed signal	Direct component with digital filter
Sensed measures	Sensed measure range 0 ÷ 999 kohm/HIGH - resolution 1 kohm	
	Thermal-probe temperature measure type Rd PT100 at 2 or 3 0÷250 °C, accuracy 2%	
	Current measure from external T.A. with secondary 5 A, accuracy 2% (selectable statement value T.A. 1÷200)	
	Impedance measure 0 ÷ 999 kohm/HIGH - resolution 1 kohm (codified composed signal)	Impedance measure 0 ÷ 999 kohm/HIGH - resolution 1 kohm (test signal 2500 Hz)
Intervention threshold	Low insulation 50 ÷ 500 kohm, accuracy 5%, hysteresis 5%, delay which can be setted	
	Overtemperature 0 ÷ 200 °C, accuracy 2%	
	Overload current 1 ÷ 999 A, accuracy 2%	
	Low impedance (which can be disarmed)	
	Link fail device	
Available output	Max. up to 4 QSD panels for remote signalling Max. up to 2 QSD panels for remote signalling	
	Programmable auxiliary relays output NA-C-NC, 5 A, 250 VAC	
	Serial output RS485, standard protocol Modbus-rtu	-
Displays	Insulation resistance value with signalling of over fullscale value and direct earth fault	
	Value of measured temperature 0 ÷ 200 °C per channel 1	
	Value of measured temperature 0 ÷ 200 °C per channel 2	
	Value of measured current 0 ÷ 999 A	
	Value insulation impedance	
	Value of network capacity to earth	-
	Setting parameters	
	Link fail	
	Relays output status	
	Memorization of min. insulation,	-
max. temperature and current values		
Connection	Max. section 2.5 sqmm	Max. section 2.5 sqmm
Operating temperature	-10 ÷ 60 °C	-10 ÷ 60 °C
Storage temperature	-25 ÷ 70 °C, humidity < 90%	-25 ÷ 70 °C, humidity < 90%
Dimensions	6 modules DIN	6 modules DIN
Weight	0.5 kg	0.5 kg
Housing	Plastic self-extinguishing housing for 35 mm	Plastic self-extinguishing housing for 35 mm
	Din rail mounting, with transparent sealable plate	Din rail mounting, with transparent sealable plate
Protection degree	IP20	IP20
Self-consumption	5 VA	5 VA
Reference standard	IEC/EN 61557-8, EN 60255-6, CE	IEC/EN 61557-8, EN 60255-6, CE



Selvtester for measurement and testing of insulated networks at 24 VAC/VDC

It is used to test permanently the insulation status of very low safety voltage circuits (up to 24V).

Function	Order details		Bbn	Price	Price	Weight	Packing
	Type code	Order code	8012542	1 piece	group	1 piece	unit
			EAN			kg	pc.
Measuring and control in insulated networks 24 VAC/VDC	SELVTESTER-24	2CSM211000R1511	884705			0.250	1

QSD panels for remote signaling for flush mounting on E 503 boxes (already included) for Isoltester-DIG and Selvtester (one per product)

They are installed in combination with insulation testers, to remotely report the signalling generated by these devices.

Version	Order details		Bbn	Price	Price	Weight	Packing
	Type code	Order code	8012542	1 piece	group	1 piece	unit
			EAN			kg	pc.
For ISOLTESTER-DIG-RZ	QSD-DIG230	2CSM310000R1521	884804			0.200	1
For SELVTESTER-24	QSD 230/24-C	2CSM110000R1521	498605			0.200	1

Technical features of Selvtester

Rated voltage Un	[V]	a.c./d.c. 24
Rated frequency	[Hz]	50-60
Network voltage to be measured	[V]	a.c. 24
Alarm threshold	[k]	adjustable 10...60
Measuring circuit voltage	[V]	<d.c 24
Load management current	[mA]	<1
Rated contact capacity In	[A]	1 (125 V ohmic)
Power consumption	[W]	10
Modules	[n°]	3
Standards		CEI 64-8, CEI 64-4
Green LED		manual opening
Yellow LED		alarm

Technical features of QSD

Opening voltage	[V]	24 d.c.
-----------------	-----	---------



EMT electronic energy meter

Highly reliable single-phase meter for measuring active energy; it is ideal for all those applications that do not require certified devices. EMT allows direct connection and indirect through C.T. This series is equipped with local reset and analogue/digital microprocessor with 5 channels for current and voltage measurement.

Description	Order details		Bbn	Price	Price	Weight	Pack
	Type code	Order code	8012542	1 piece	group	1 piece	unit
			EAN			kg	pc.
Single phase energy meter (local reset, direct/indirect reading)	EMT	2CSM113000R1011	620808			0,320	1

Technical features

Rated voltage U_n	[V]	a.c. 230 ±10% single-phase
Direct insertion current	[A]	up to 25
Indirect insertion current	[A]	through C.T. (by choice)/5A
Protection fuse	[A]	max 25
Rated frequency	[Hz]	50/60
Measurement range	[kWh]	0...9999
Overload capacity		1.2In/Vn
Set transformation ratios		12, 20, 50, 120, 200
Accuracy rating	[%]	2
Data storage		through internal EEPROM
Power consumption	[W]	2
Protection degree	[IP]	20
Operating temperature	[°C]	-40 +70
Modules	[#]	3
Standards		EN 62053-21

EMT wiring diagrams

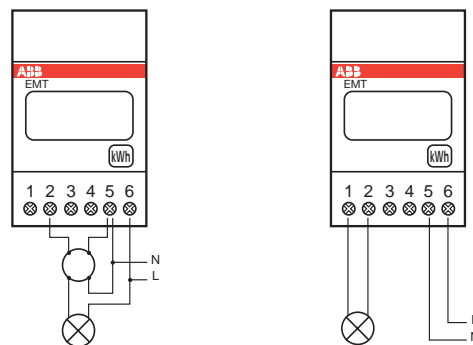

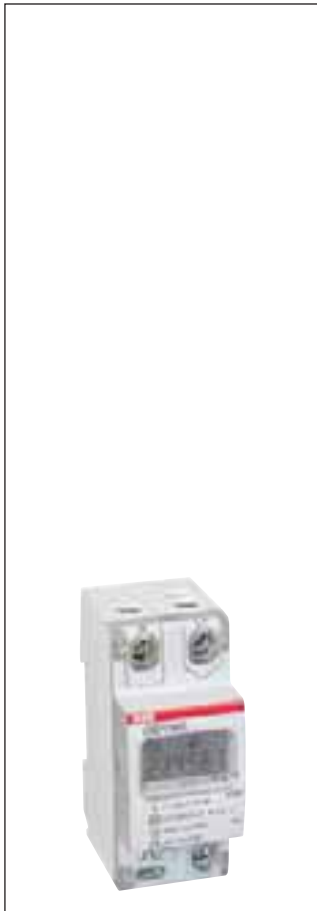

ODINsingle electronic single phase energy meters

ODINsingle is intended for mounting on a DIN rail and is designed in accordance with the ABB Pro *M* standard.

General Features

ODINsingle is an active energy, single phase meter for direct metering up to 65A. The LCD display has 6 digits, 6 mm high to ensure easy reading. ODINsingle is made compact, only 2 modules (35 mm) to save space in the installation. In case of power failure, the meter is equipped with a EE prom. A red LED at the front flashes proportionally to the energy consumed. ODINsingle has a temperature range from -25 to +55 (storage +70 °C)

Communication

ODINsingle has 3 ways to communicate depending on type.

- Display at front
- Pulse output (option)
- IR interface for serial communication (together with serial communication adapter)

Type Approval

All ODINsingle types are tested and approved according to EN 50470-1, EN 50470-3, (IEC 62052-11 and 62053-21). These standards cover all technical aspects of the meter like climate conditions, electromagnetic compatibility (EMC), electrical requirements, mechanical requirements and accuracy.

Voltage (V)	Pulse output frequency	Order details	Bbn 7392696	Price 1 piece	Price group	Weight 1 piece	Pack unit
		Type code	Order code	EAN			

OD1065 direct connected, single phase meter 65A

230	-	OD1065	2CMA131040R1000			0.130	1
-----	---	--------	-----------------	--	--	-------	---

OD1365 direct connected, single phase meter 65A, pulse output and resetable

230	100 imp/kWh	OD1365	2CMA131041R1000			0.130	1
-----	-------------	--------	-----------------	--	--	-------	---

Technical features

Rated voltage Un	[V]	a.c. 230, -20% to +15%
Direct insertion current	[A]	up to 65
Protection fuse	[A]	63
Rated frequency	[Hz]	50
Starting current	[mA]	20
Pulse output max frequency	[imp]	100
Pulse output max current	[mA]	100
Impulse amplitude	[ms]	100
Accuracy rating	[%]	1
Power consumption	[W]	<1.0 VA
Protection degree	[IP]	20
Operating temperature	[°C]	-25 to +55
Modules	[No]	2
Standards		EN 50470-1, EN 50470-3 (IEC 62052-11, IEC 62053-21)

ODINsingle wiring diagrams

Direct connection

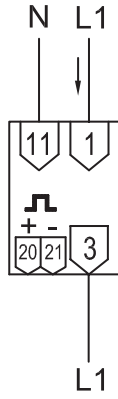

Pulse output

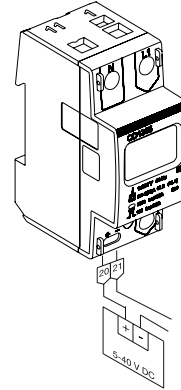

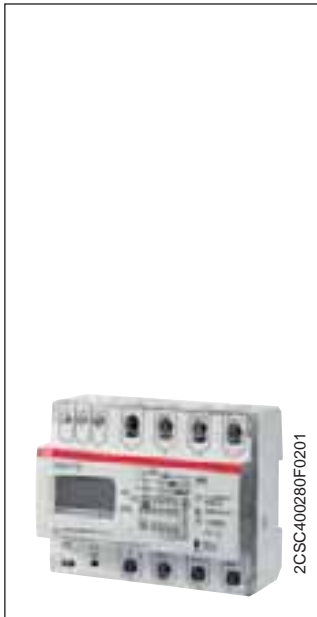

ODIN Meter electronic three-phase energy meters

ODIN Meter is a compact three-phase meter for measuring active energy, designed for mounting on DIN rail, on panel and for flush mounting in distribution switchboard or standard boxes. It is designed and developed to offer extremely easy application and it is equipped with terminals with transparent scores and strong holding screws for connecting cables and terminal boards, phase bus connectors, easy to read 7-digit display, current direction indicator, clear mounting instructions with text and diagrams on the device.

ODIN Meter is a highly reliable and strong meter that maintains the highest measuring accuracy in time.

ODIN Meter energy meters are standardized according to the international Standards IEC 62052-11 and IEC 62053-21.

Accuracy class: 2

Active energy meter 3x230/400 (three-phase+N)

Description	Order details		Bbn	Price	Price	Weight	Pack
	Type code	Order code	7392696	1 piece	group	1 piece	unit
			EAN			kg	pc.
direct up to 65A, impulsive output 100 Imp./kWh	OD4165	2CMA131024R1000	310246			0.320	1
indirect with CT/5A, impulsive output 1 Imp./kWh	OD4110	2CMA131025R1000	310253			0.320	1

ODIN series wiring diagrams

- Direct connection

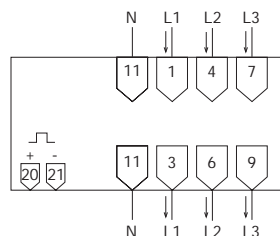

- Indirect connection (through C.T.)

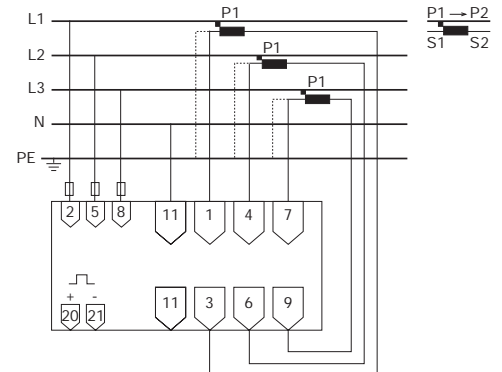

Technical features

	Direct measuring/connection	Connection through A.T.
Voltage	3x230/400 V (-20% to +15%)	3x230/400 V (-20% to +15%)
Current	65 A	10 A
Frequency	50/60 Hz	50/60 Hz
Selection of insertion currents through C.T.		5/5, 75/5, 100/5, 150/5, 200/5, 250/5, 300/5, 400/5, 500/5, 600/5, 700/5, 750/5, 800/5, 900/5 A
Starting current	25 mA	15 mA
Pulsive output max. voltage	5...40 V	...40 V
Pulsive output max. current	100 mA	100 mA
Accuracy	2 ±2% class	2 ±2% class
Display	7-digit LCD	7-digit LCD
Protection degree	IP 20	IP 20
Operating temperature	-25 + 55 °C	25 + 55 °C
Standards	IEC 62052-11 and IEC 62053-21	IEC 62052-11 and IEC 62053-21

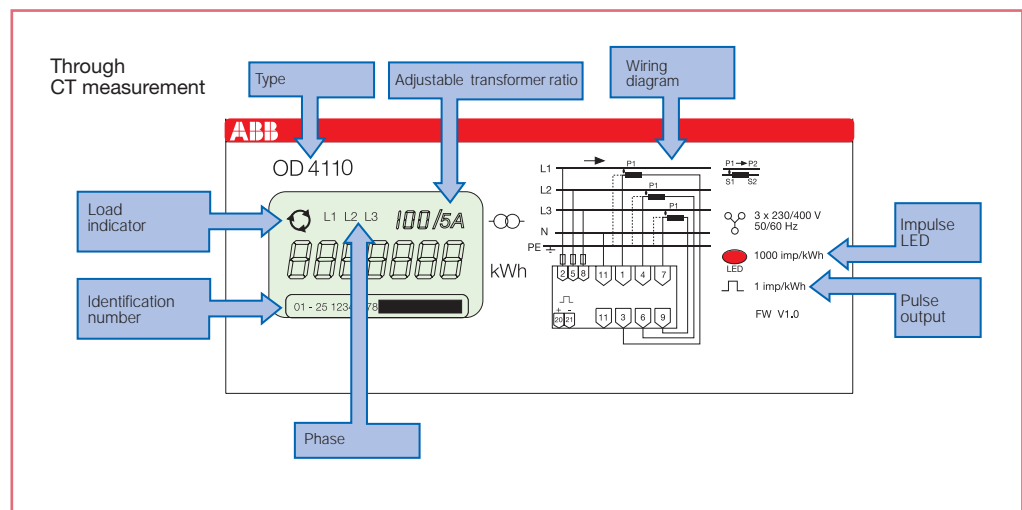
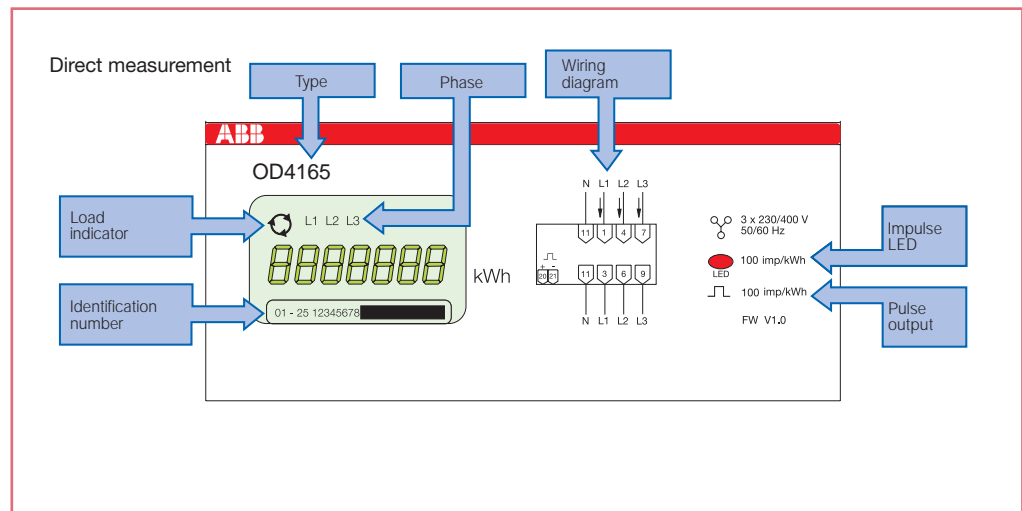

DELTAsingle electronic single phase energy meters

DELTAsingle is an electronic electricity meter for single phase metering. The meter has an internal clock for handling tariffs. The setting is done with push buttons. DELTAsingle is intended for mounting on a DIN rail and is designed in accordance with the ABB ProM standard.

General Features

DELTAsingle is an active energy, single phase meter for direct metering up to 80 A. The LCD display has 6 digits, 6 mm high to ensure easy reading.

DELTAsingle is made compact, only 4 modules (72 mm) to save space in the installation.

In case of power failure, the meter is equipped with a Super Cap power backup that will run the clock for 48 hours. A red LED at the front flashes proportionally to the energy consumed.

DELTAsingle has a temperature range from -40 to +55 (storage +70 °C)

Communication

DELTAsingle has 3 ways to communicate depending on type.

- Display at front
- Pulse output
- IR interface for serial communication (together with serial communication adapter)

Programming

Selection of information to be shown on the display is easily achieved by using push buttons. The programming / push button can be sealed.

Tariffs

The DELTAsingle range includes 1, 2 and 4 tariffs meters.

Type Approval

All DELTAsingle meter types are tested and approved according to EN 50470-1 and EN 50470-3 (IEC 62052-11 and IEC 62053-21). These standards cover all technical aspects of the meter like climate conditions, electromagnetic compatibility (EMC), electrical requirements, mechanical requirements and accuracy. DELTAsingle meter also carries a number of national approvals.



2CSC400142F0201

Description	Order details		Bbn	Price	Price	Weight	Pack
	Type code	Order code	7392696	1 piece	group	1 piece	unit
			EAN			kg	pc.
Without pulse output	FBU 11200	2CMA180891R1000	808910			0.150	1
With pulse output	FBB 11200	2CMA180892R1000	808927			0.150	1
Without pulse output	FBU 11205	2CMA180893R1000				0.150	1
With pulse output	FBB 11205	2CMA180894R1000				0.150	1
Without pulse output	FBU 11206	2CMA180895R1000				0.150	1
With pulse output	FBB 11206	2CMA180896R1000				0.150	1

MID - Measuring Instrument Directive

The European parliament decided in 2004 to establish a new directive for measuring instrument. The MID directive took affect at the 30th of October 2006 and each member country has to take this directive into the national legislation latest April 2006.

The MID directive means:

- Common testing rules based on IEC standards for all EU and EES countries. EN 50470-1 and EN 50470-3.
- No need for local testing/approval. Test performed in one EU country must be accepted in all EU and EES countries.
- No special national requirements of any kind are allowed.

On the product as well as on the packing you find a label certifying that the ABB electricity meter is tested and approved according to MID directive.

Technical features

General features

Voltage	[V]	230 AC
Voltage range		-23 % to +20 %
Max current	[A]	80
Start current	[mA]	40
Power consumption of current circuit	[VA]	< 1.3
Frequency	[Hz]	50/60 (± 5 %)
Accuracy of measurement		Class 1 (± 1 %)
Memory backup		EEPROM
Clock backup		Super Cap. 48h
Clock accuracy		IEC 62054-21
Standard		EN 50470-1 and EN 50470-3 (IEC 62052-11 and IEC 62053-21)
Temperature range	[°C]	-40 to +55
Material of front cover		Polycarbonate
Material of back cover		Polycarbonate/glass fibre
Resistance to heat and fire		IEC 695-2-1
Protection against penetration of dust and water	[IP]	20
Connection area in the current connecting terminals	[mm ²]	1 - 25
Weight	[gr]	150

Pulse output

Connection area in the connecting terminal	[mm ²]	0.5 - 2.5
External pulse voltage	[V]	5 - 40 DC
Max. current	[mA]	100
Pulse length	[ms]	100
Pulse frequency		100 imp/kWh
Standard		IEC 62053 (So)

LED

Pulse frequency		1000 imp/kWh
Pulse length	[ms]	40

Display		LCD with 6 digits, 6 mm
----------------	--	-------------------------



DELTAplus electronic three-phase energy meters

DELTAplus meters are designed to offer extremely easy and simple application. Suitable for mounting on DIN rail, lightweight and small, they are ideal for the installation on switchboards, feeder panels and enclosed. The range includes devices for measuring active energy, reactive energy and the combination of active and reactive energy. All DELTAplus meters are standardized according to the international Standards IEC 62052-11 and IEC 62053-21 (for active energy) and IEC 62053-23 (for reactive energy), accuracy class 1 and 2 according to the type.

Description	Order details	Bbn	Price	Price	Weight	Pack
	Type code	Order code	1 piece	group	1 piece	unit
					kg	pc.

Active energy meter for direct connection up to 80 A, class 2

3 x 100-500 V AC (3F)	DBB 22 00 0	2CMA180802R1000	808026		0.320	1
3 x 100-500/57-288 V AC (3F+N)	DBB 23 00 0	2CMA180800R1000	808002		0.320	1
3 x 100-500/57-288 V AC (3F+N) + act/react	DDB 13 00 0	2CMA180810R1000	808101		0.320	1

Active energy meter for direct connection through C.T. /5 A, class 2

3 x 100-500 V AC (3F)	DAB 12 00 0	2CMA180807R1000	808071		0.320	1
3 x 100-500/57-288 V AC (3F+N)	DAB 13 00 0	2CMA180806R1000	808064		0.320	1
3 x 100-500/57-288 V AC (3F+N) + act/react	DCB 13 00 0	2CMA180808R1000	808088		0.320	1

Auxiliary elements/accessories

Long cover	DELTA/CPL	2CMA132633R1000	326339		0.320	1
DIN rail	DELTA/DIN	2CMA132540R1000	325400		0.320	1
Surface panel	DELTA/FRQ	2CMA132635R1000	325417		0.320	1

Technical features

Voltage	[V]	up to 500 V (3F and 3F+N)
Current	[A]	≤80 (direct connection); >80 (indirect connection through C.T.)
Frequency	[Hz]	50/60
Starting current	[mA]	20 (direct connection 2 CT)
Pulse output frequency	[imp/kWh]	programmable
Impulse amplitude	[ms]	100, basic version
Frequency of blinking of LED and LCD segments	[imp/kWh]	5000, basic version
Pulse output		
-max. current	[mA]	100
-max. voltage	[V a.c./d.c.]	247
-max. cable section	[mm ²]	2.5
-standards		IEC 62053 for pulse output
Standards		EN 50470-1 and EN 50470-3 (IEC 62052-11 and IEC 62053-21 for active energy meters; IEC 62053-23 for reactive energy meters)
Accuracy		Class 1 or 2
Display		LCD (liquid crystal) with 7 digits, h=7mm
Terminal holder		10 mm ² (insertion through C.T.); 25 mm ² (direct insertion)
Protection degree		IP51 (IP20 on the terminal holder without cover)
Operating temperature	[°C]	-40 +70
Power consumption	[W]	1.5
Modules	[No]	7

Wiring diagrams

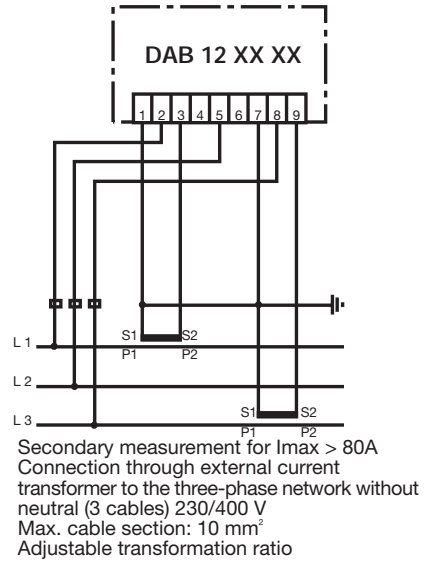
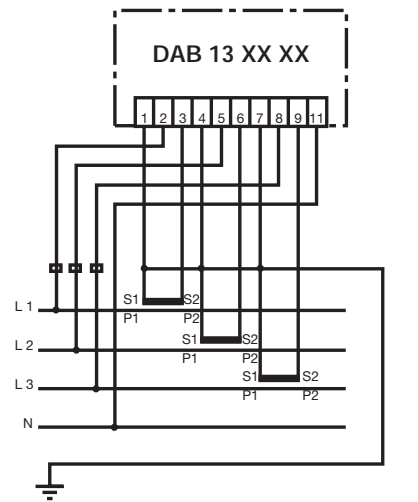
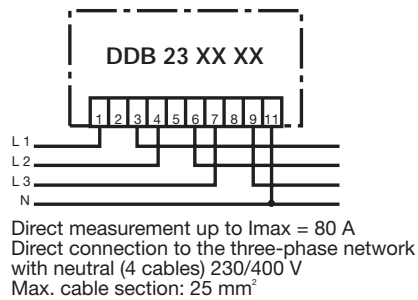
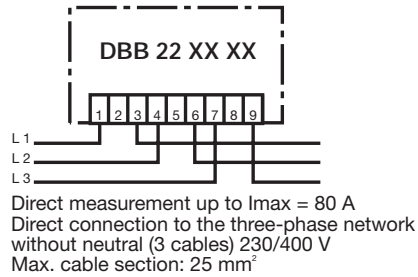

Notes

For connections through current transformer, C.T. must have 5 A or 1 A secondary and be connected according to correct polarities: P1->P2, S1->S2

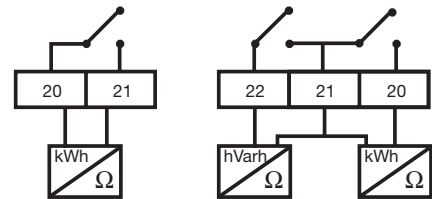

2-pole balanced or 3-pole unbalanced output for sending to a personal computer information from energy meter, encoded as numerical signal. Some types enable to connect an external voltage to control teletest

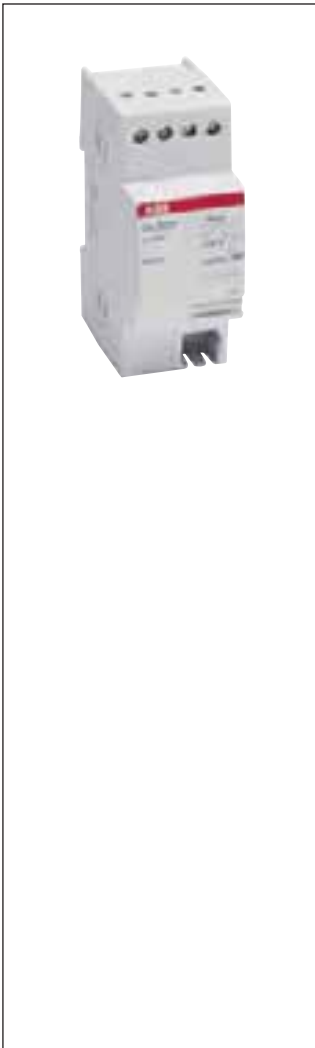

Module	Protocol/Media	Order details	Bbn	Price	Price	Weight	Pack
		Type code	7392696	1 piece	group	1 piece	unit
			EAN			kg	pc.
Serial Communication Adapter							
M-bus	M-Bus/M-Bus Twisted pair	CTM04000	2CMA137090R1000			0.090	1
RS232	M-Bus/RS232	CRM04000	2CMA137091R1000			0.090	1
Ethernet	M-Bus over TCP or UDP/Ethernet	CEM05000	2CMA137099R1000			0.090	1
LON PLC A-band	LONWorks/ Power Line	CAL06000	2CMA137100R1000			0.090	1
LON PLC C-band	LONWorks/ Power Line	CCL06000	2CMA137103R1000			0.090	1



Index

Selection tables	
TS-C safety isolating transformers for general use	10/2
TM/TS bell transformers	10/3
CP-D primary switch mode power supplies	10/5
Bells and buzzers	10/6
Modular sockets	10/8
MA1 8001 DIN rail adapter	10/11



TS-C safety isolating transformers for general use

They are ideal for supplying permanent power to meters, auxiliary electronic devices (e.g. measurement, video-entry phone systems, BUS communication) and circuits with very low safety voltage (SELV) for bathrooms and showers, lighting, fountains, electro-medical devices and suchlike. The main feature of these new devices is that they take up very little space in the 4-module size for the 25 and 40 A versions and the 5-module size for the 63 VA versions.

Secondary rated voltage	Rated power (continuous)	Order details		Bbn	Weight	Pack unit
V	VA	Type code	Order code	EAN	kg	pc.

TS-C transformers short-circuit proof not by construction

12-24	25	TS 25/12-24 C	2CSM251043R0811	928508	0,465	1
12-24	40	TS 40/12-24 C	2CSM401043R0811	928607	0,465	1
12-24	63	TS 63/12-24 C	2CSM631043R0811	928706	0,465	1

Technical features

Primary rated voltage Un	[V]	230 AC	
Secondary rated voltage Un	[V]	12, 24	
Rated frequency	[Hz]	50/60	
Rated power	[VA]	25,40,63 (continuous use)	
Power loss	25 VA	[W]	5
	40 VA	[W]	10
	63 VA	[W]	18,7
Modules	[n°]	4, 5	
Standards		IEC/EN 61558-2-6	

Wiring diagrams and marking information

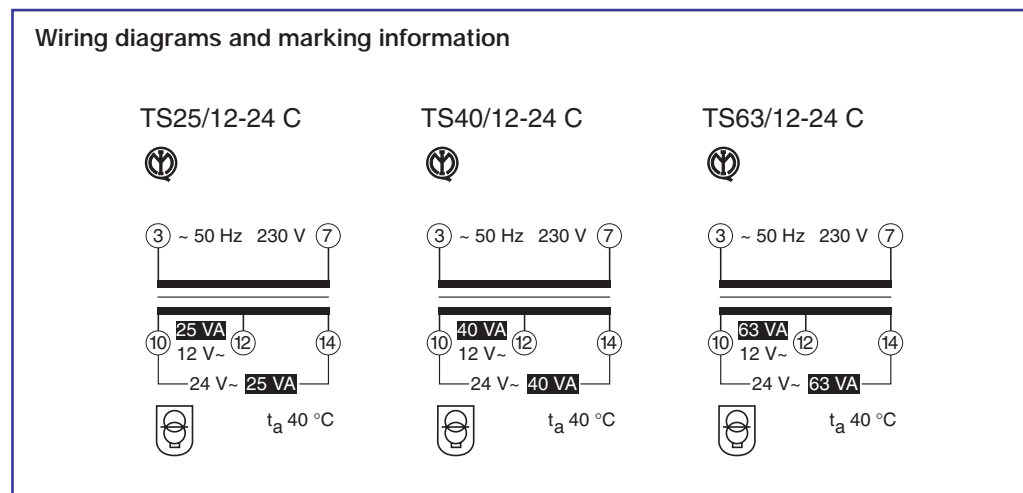

TM/TS bell transformers

These transformers with secondary in extremely low safety voltage for feeding bells (discontinuous use) are available in 4 series:

- failure-proof (TM series)
- non-inherently short-circuit proof (TS8 series)
- non-inherently short-circuit proof with switch 0-1 (TS8/SW series)
- non-inherently short-circuit proof (TS16/TS24 series).

Secondary rated voltage (discontinuous)	Rated power (discontinuous)	Order details	Bbn	Price	Price group	Weight	Pack
V	VA	Type code	8012542	1 piece		1 piece	unit
			EAN			kg	pc.

TM series failsafe transformers

Secondary rated voltage (discontinuous)	Rated power (discontinuous)	Order details	Bbn	Price	Price group	Weight	Pack
V	VA	Type code	8012542	1 piece		1 piece	unit
			EAN			kg	pc.
4-8-12	3.33-6.66-10	TM10/12	2CSM101021R0801	367109		0.300	6
12-24	5-10	TM10/24	2CSM101041R0801	367208		0.300	6
4-8-12	5-10	TM15/12	2CSM151021R0801	367307		0.300	6
12-24	7.5-15	TM15/24	2CSM151041R0801	367406		0.300	6
4-8-12	10-20-30	TM30/12	2CSM301021R0801	367505		0.450	4
12-24	15-30	TM30/24	2CSM301041R0801	367604		0.450	4
4-8-12	13-27-40	TM40/12	2CSM401021R0801	367703		0.450	4
12-24	20-40	TM40/24	2CSM401041R0801	367802		0.450	4

TS8 series non-inherently short-circuit proof transformers

Secondary rated voltage (discontinuous)	Rated power (discontinuous)	Order details	Bbn	Price	Price group	Weight	Pack
V	VA	Type code	8012542	1 piece		1 piece	unit
			EAN			kg	pc.
8	8	TS 8/8	2CSM081301R0811	36800 7		0.355	6
12	8	TS 8/12	2CSM081401R0811	36810 6		0.355	6
24	8	TS 8/24	2CSM081501R0811	36820 5		0.355	6

TS8 series non-inherently short-circuit proof transformers with switch 0-1

Secondary rated voltage (discontinuous)	Rated power (discontinuous)	Order details	Bbn	Price	Price group	Weight	Pack
V	VA	Type code	8012542	1 piece		1 piece	unit
			EAN			kg	pc.
8	8	TS 8/8 sw	2CSM081302R0811	36830 4		0.277	6
12	8	TS 8/12 sw	2CSM081402R0811	36840 3		0.277	6
4-6-8	8	TS 8/4-6-8 sw	2CSM081012R0811	36860 1		0.280	6
4-8-12	8	TS 8/4-8-12 sw	2CSM081022R0811	36870 0		0.280	6

TS16 series non-inherently short-circuit proof transformers

Secondary rated voltage (discontinuous)	Rated power (discontinuous)	Order details	Bbn	Price	Price group	Weight	Pack
V	VA	Type code	8012542	1 piece		1 piece	unit
			EAN			kg	pc.
8	16	TS 16/8	2CSM161301R0811	36880 9		0.355	6
12	16	TS 16/12	2CSM161401R0811	36890 8		0.355	6
24	16	TS 16/24	2CSM161501R0811	36900 4		0.330	6
4-6-8	16	TS 16/4-6-8	2CSM161011R0811	36910 3		0.333	6
4-8-12	16	TS 16/4-8-12	2CSM161021R0811	36920 2		0.333	6
4-8-12	24	TS 24/4-8-12	2CSM241021R0811	36930 1		0.465	4
8-12-24	24	TS 24/8-12-24	2CSM241031R0811	36940 0		0.465	4

Technical features

Primary rated voltage U_n	[V]	a.c. 230
Secondary rated voltage U_n	[V]	4, 6, 8, 12, 24
Rated frequency	[Hz]	50/60
Rated power	[VA]	8, 10, 15, 16, 24, 30, 40 (discontinuous use)
Modules	[n°]	2, 3
Standards		IEC/EN 61558-2-8



Wiring diagram and marking information

<p>TM10/12</p>	<p>TM10/24</p>	<p>TS8/8</p>	<p>TS8/8 SW</p>	<p>TS16/8</p>	<p>TS24/4-8-12</p>	
<p>TM15/12</p>	<p>TM15/24</p>	<p>TS8/12</p>	<p>TS8/12 SW</p>	<p>TS16/12</p>	<p>TS24/8-12-24</p>	
<p>TM30/12</p>	<p>TM30/24</p>	<p>TS8/24</p>	<p>TS8/4-6-8 SW</p>	<p>TS16/24</p>		
<p>TM40/12</p>	<p>TM40/24</p>	<p>TS8/4-8-12 SW</p>	<p>TS16/4-6-8</p>			
				<p>TS16/4-8-12</p>		

Primary switch mode power supplies



CP-D 12/0.83,
CP-D 24/0.42



CP-D 12/2.1
CP-D 24/1.3



CP-D 24/2.5



CP-D 24/4.2

Type	Rated input voltage	Rated output voltage / current	Order code	Pack. unit pieces	Price 1 piece	Weight 1 piece kg/lb
CP-D 12/0.83	100-240 V AC	12 V DC / 0.83 A	1SVR 427 041 R1000	1		0.06/0.13
CP-D 12/2.1	100-240 V AC	12 V DC / 2.1 A	1SVR 427 043 R1200	1		0.19/0.41
CP-D 24/0.42	100-240 V AC	24 V DC / 0.42 A	1SVR 427 041 R0000	1		0.06/0.13
CP-D 24/1.3	100-240 V AC	24 V DC / 1.3 A	1SVR 427 043 R0100	1		0.19/0.41
CP-D 24/2.5	100-240 V AC	24 V DC / 2.5 A	1SVR 427 044 R0200	1		0.25/0.55
CP-D 24/4.2	100-240 V AC	24 V DC / 4.2 A	1SVR 427 045 R0400	1		0.32/0.71

- Output voltages 12 V, 24 V
- Adjustable output voltages (devices > 10 W)
- Output currents 0.42 A / 0.83 A / 1.3 A / 2.1 A / 2.5 A / 4.2 A
- Power range 10 W, 30 W, 60 W, 100 W
- Wide range input 100-240 V AC (90-264 V AC, 120-370 V DC)
- High efficiency of up to 89 %
- Low power dissipation and low heating
- Free convection cooling (no forced cooling with ventilators)
- Ambient temperature range during operation -10...+70 °C
- Open-circuit, overload and short-circuit stable
- Integrated input fuse
- U/I characteristic (fold-forward behaviour at overload – no switch-off)
- LEDs for status indication
- Light-grey enclosure in RAL 7035



Bells and buzzers

Characterized by discontinuous use through one or more pushbuttons, bells and buzzers are suitable for public and tertiary acoustic signalling.

Rated voltage	Order details	Bbn	Price	Price group	Weight	Pack unit
V AC	Type code	Order code	1 piece		1 piece	pc.

SM-1 electro-mechanical modular bells in 1 module (intermittent use)

Rated voltage	Type code	Order code	Bbn	Price	Price group	Weight	Pack unit
12	SM1-12	2CSM111000R0821	886204			0.076	12
230	SM1-230	2CSM131000R0821	886303			0.076	12

SM-2 electro-mechanical modular bells in 1 module (continuous use)

Rated voltage	Type code	Order code	Bbn	Price	Price group	Weight	Pack unit
12	SM2-12	2CSM112000R0821	886600			0.076	12
24	SM2-24	2CSM122000R0821	886709			0.076	12
230	SM2-230	2CSM132000R0821	886808			0.076	12

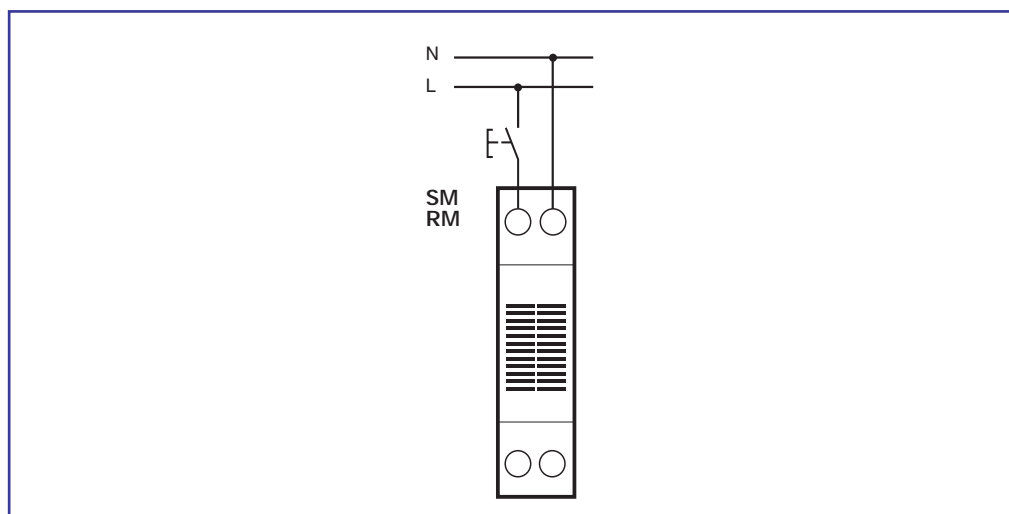

Technical features

		SM1-12	SM1-230	SM2-12	SM2-24	SM2-230
		RM1-12	RM1-230	RM2-12	RM2-24	RM2-230
Rated Voltage Un	[V a.c.]	8-12	230	12	24	230
Rated frequency	[Hz]	-		50		
Power consumption	[VA]	2.5-6.5	4	4	4	4
Sound level at 1 meter	SM [dB]			82		
	RM [dB]			80		
Max permanent working time	[min]	15		-		-
	[h]	-		-		12
Max cable cross-section	[mmq]	-		10		
Protection degree		-		IP40		
Modules	[n°]	-		1		



RM-1 modular buzzers in 1 module (intermittent use)

12	RM1-12	2CSM211000R0821	886419	0.076	12
230	RM1-230	2CSM231000R0821	886518	0.076	12

RM-2 modular buzzers in 1 module (continuous use)

12	RM2-12	2CSM212000R0821	886907	0.076	12
24	RM2-24	2CSM222000R0821	887003	0.076	12
230	RM2-230	2CSM232000R0821	887102	0.076	12

TSM modular electronic bell + 10 VA transformer (two-tones), 2 modules

12	TSM	2CSM100000R0841	007005	0.300	6
----	-----	-----------------	--------	-------	---

TSR bell + buzzer + transformer, 2 modules

24	TSR	2CSM100000R0831	369608	0.300	1
----	-----	-----------------	--------	-------	---

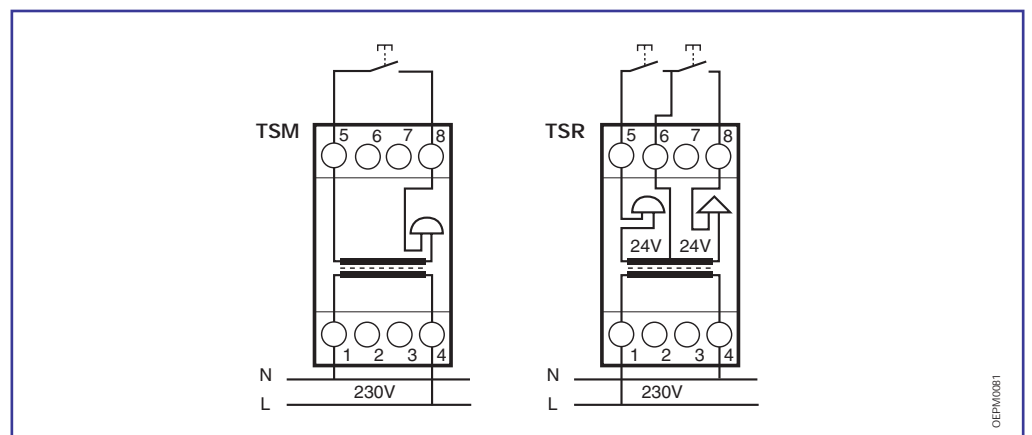

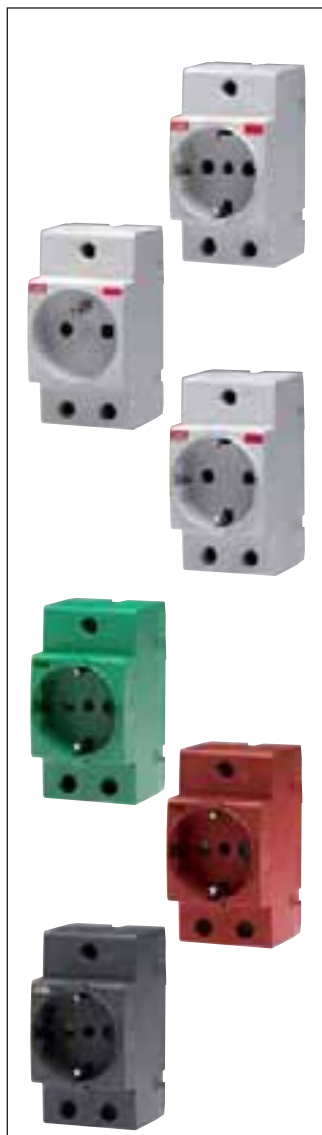

Modular sockets

Modular sockets allow the connection of devices, tools or electrical and electronic non modular equipments in civil and industrial electrical switchboards.

In addition to the grey-coloured version there are three other colours which are useful to indicate specific socket uses:

- green, for example to indicate a dedicated upstream protection device;
- red, for example to indicate an UPS group that allows the socket to be used if the main power supply fails;
- black, to be combined with industrial and automation devices.

The range is completed by versions with an integrated light to indicate the presence of voltage and versions with protection fuse.

Color	Description	Bbn 80122542	Weight 1 piece	Pack unit
Type	Order code	EAN	kg	

Italian/German dual standard modular sockets

The M1170 series takes Italian standard P11/P17 plugs and Schuko plugs up to 16 A

grey (RAL 7035)	M1170	2CSM210000R0701	027454	0,120	4
green (RAL 6029)	M1170-G	2CSM220000R0701	027553	0,120	4
red (RAL 3000)	M1170-R	2CSM230000R0701	027652	0,120	4
black (RAL 7012)	M1170-B	2CSM240000R0701	027751	0,120	4

Italian and German standard modular sockets

The M1173 series (IMQ certified) takes Italian standard plugs and Schuko plugs up to 16 A

grey (RAL 7035)	M1173	2CSM110000R0701	004103	0,120	4
green (RAL 6029)	M1173-G	2CSM120000R0701	026754	0,120	4
red (RAL 3000)	M1173-R	2CSM130000R0701	026853	0,120	4
black (RAL 7012)	M1173-B	2CSM140000R0701	026952	0,120	4

Italian and German standard modular sockets with integrated indicator light

grey (RAL 7035) with light	M1173-L	2CSM112000R0701	027058	0,140	4
green (RAL 6029) with light	M1173-L-G	2CSM122000R0701	027157	0,140	4
red (RAL 3000) with light	M1173-L-R	2CSM132000R0701	027256	0,140	4
black (RAL 7012) with light	M1173-L-B	2CSM142000R0701	027355	0,140	4

Fuse detail



Indicator light detail



Front view

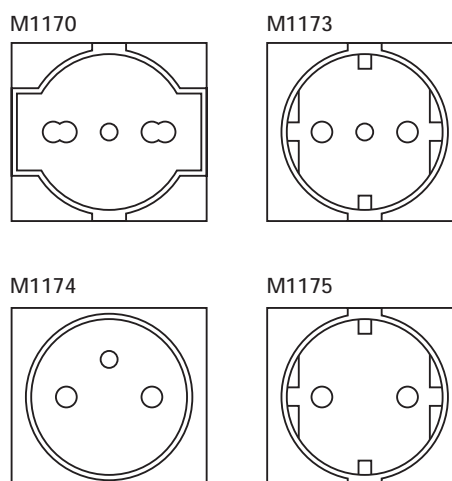

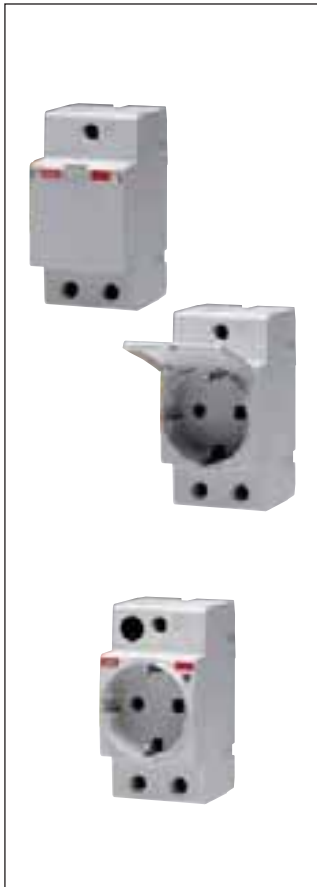

French-standard modular sockets

The M1174 series (LCIE certified) takes standard French plugs up to 16 A

grey (RAL 7035)	M1174	2CSM110000R0711	06602	0,140	4
-----------------	--------------	-----------------	--------------	-------	---

German-standard modular sockets

The M1175 series (VDE certified) takes Schuko standard plugs up to 16 A. Also available with cover, M1175-C.

grey (RAL 7035)	M1175	2CSM210000R0721	027850	0,120	4
green (RAL 6029)	M1175-G	2CSM220000R0721	027959	0,120	4
red (RAL 3000)	M1175-R	2CSM230000R0721	028055	0,120	4
black (RAL 7012)	M1175-B	2CSM240000R0721	028154	0,120	4
grey (RAL 7035) with cover	M1175-C	2CSM211000R0721	029052	0,140	4
green (RAL 6029) with cover	M1175-C-G	2CSM221000R0721	029151	0,140	4
red (RAL 3000) with cover	M1175-C-R	2CSM231000R0721	029250	0,140	4
black (RAL 7012) with cover	M1175-C-B	2CSM241000R0721	029359	0,140	4

Italian/German modular sockets with integrated indicator light and/or fuse

grey (RAL 7035) with light	M1175-L	2CSM212000R0721	028253	0,140	4
green (RAL 6029) with light	M1175-L-G	2CSM222000R0721	028352	0,140	4
red (RAL 3000) with light	M1175-L-R	2CSM232000R0721	028451	0,140	4
black (RAL 7012) with light	M1175-L-B	2CSM242000R0721	028550	0,140	4
grey (RAL 7035) with light and fuse	M1175-FL	2CSM214000R0721	028659	0,160	4
green (RAL 6029) with light and fuse	M1175-FL-G	2CSM224000R0721	028758	0,160	4
red (RAL 3000) with light and fuse	M1175-FL-R	2CSM234000R0721	028857	0,160	4
black (RAL 7012) with light and fuse	M1175-FL-B	2CSM244000R0721	028956	0,160	4

Technical specifications

Rated voltage Un	[V]	250
Rated current In	[A]	16
Rated frequency	[Hz]	50/60
Power consumption	[W]	0,6
Modules	[n°]	2,5
Safety shutters		yes, on entire range
Terminal type		positive safety
Cable section (ø min./max.)	[mm ²]	2,5 / 16
Tightening torque	[Nm]	1,2
Temperature		
storage	[°C]	-40 ... +70
operating	[°C]	-25 ... +35
Protection degree		IP20
Reference standards		CEI EN 60715, CEI 23-50 (M1173), NF C 61 303 (M1174), DIN VDE 0620-1 (M1175)
Approvals		IMQ (M1173), LCIE (M1174), CEBEC (M1174), VDE (M1175), GOST

Technical specifications of indicator light

Type		fluorescent torpedo lamp not replaceable
Function		signal of the presence of voltage
Colour of light		green
Power consumption	[W]	0:25

Technical specifications of fuse

Type		5 x 20 mm up to 6.3 A aM
------	--	--------------------------

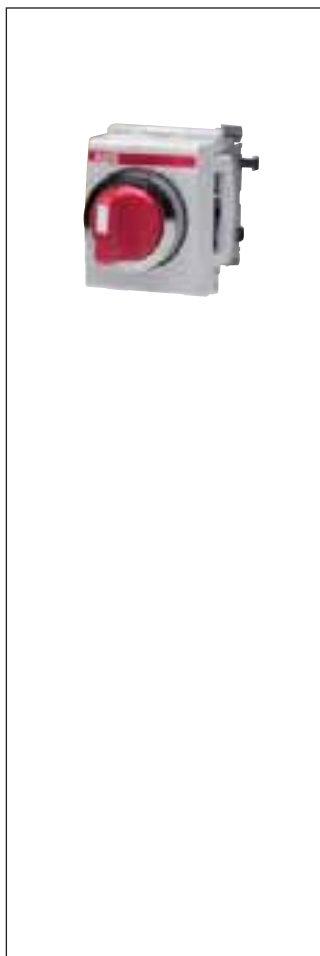

MA1-8001 DIN rail adapter

Through an appropriate kit, this housing makes control and signalling units for industrial use (pushbuttons, indicators, selectors, etc.) uniform to modular devices according to DIN rail.

Description	Order details	Bbn	Price	Price group	Weight	Pack unit
	Type code	Order code	7320500	1 piece	1 piece	kg
			EAN			pc.
DIN rail adapter ⁽¹⁾	M1173	1SFA611920R8001	DIN Rail adapter	175262	0,023	10

⁽¹⁾ Can be used only with modular series control and warning units; it cannot be used with products from the old CBK series or from the monobloc series.

Technical notes

- To assemble the new housing with buttons, selectors and indicator lamps, contacts and lamp sockets for DIN rails must be used.
- The MCBH-00 frame must not be used because the housing hooks directly to the contacts.
- To use with modular products, 3 contacts may be used.
- In the configuration with 3 contacts, it is advisable to use securing pins to make the blocks more solid.
- In making up actuators or indicator lamps that use a single contact, one or two SK616009-B empty blocks must be used.

Wiring diagram

After hooking the contact blocks and/or lamp socket on the DIN rail, inserting the securing pins (if necessary) and cabling the contacts:

- 1) insert the button, selector or indicator lamp where desired;
- 2) tighten the affixing ring nut using the special spanner;
- 3) hook the housing to the empty blocks for the DIN rail, contact and/or lamp socket.

Index

MCBs

Tripping characteristics	11/2
Limitation of specific let-through energy I^2t	11/3
Peak current I_p	11/10
Coordination tables	11/16
MCBs internal resistance, power loss and max. permissible earth-fault loop impedance ..	11/51
Performances at different ambient temperatures, altitudes and frequencies	11/53
Use of MCBs in direct current circuits	11/55
Particular supply sources and loads	11/56
Double stamping of S 200 P	11/59
Wiring diagrams of MCBs	11/60

RCDs

Functions and classification criteria for RCDs	11/61
Influence on RCDs of currents with DC components	11/64
Coordination tables	11/65
Power loss, derating and performance in altitude	11/69
Emergency stop using DDA 200 AE series	11/70
Unwanted tripping - AP-R solution	11/71
Type B RCDs	11/72
Use of 4P RCCBs in 3-phase system without neutral pole	11/74
Operating voltage of test button	11/75
Wiring diagrams of RCCBs, RCBOs and RCD-blocks	11/79

SPDs

Terminology of SPD electrical characteristics	11/82
Common mode and/or differential mode protection	11/83
Principle of coordination for Surge Protective Devices	11/84
Operating diagrams of Surge Protective Devices	11/85
Installation rules for SPDs: choice of associated breaking devices (fuse/circuit breaker)	11/88
Cabling and installation of Surge Protective Devices in an electrical panel	11/89

MDRCs

Protection devices

RD2 residual current monitors	11/90
Toroidal transformers	11/91
E 930 fuse holders	11/93
M2160-M2060 fuse switches	11/94

Command devices

E 259 installation relays	11/95
E 250 latching relays	11/96

Load management devices

LSS1/2 load shedding switch	11/99
Max./min. current/voltage ammetric and voltmetric relays	11/100

Measurement devices

Analogue and digital measurement instruments and accessories	11/102
Insulation monitors	11/115

Other functions

Modular transformers	11/118
----------------------------	--------

Tripping characteristics

Acc. to	Tripping characteristic and rated current	Thermal release ①		Tripping time	Electromagnetic release ②		Tripping time
		Current: conventional non-tripping c.	conventional tripping c.		Currents: hold current surges	trip at least at	
IEC/EN 60898	B 6 to 63 A	$1.13 \cdot I_n$	$1.45 \cdot I_n$	$> 1 \text{ h}$ $< 1 \text{ h}$	$3 \cdot I_n$	$5 \cdot I_n$	$> 0.1 \text{ s}$ $< 0.1 \text{ s}$
	C 0.5 to 63 A	$1.13 \cdot I_n$	$1.45 \cdot I_n$	$> 1 \text{ h}$ $< 1 \text{ h}$	$5 \cdot I_n$	$10 \cdot I_n$	$> 0.1 \text{ s}$ $< 0.1 \text{ s}$
	D 0.5 to 63 A	$1.13 \cdot I_n$	$1.45 \cdot I_n$	$> 1 \text{ h}$ $< 1 \text{ h}$	$10 \cdot I_n$	$20 \cdot I_n$	$> 0.1 \text{ s}$ $< 0.1 \text{ s}$
DIN VDE 0660/9.82	K 0.5 to 63 A	$1.05 \cdot I_n$	$1.2 \cdot I_n$	$> 1 \text{ h}$ $< 1 \text{ h}$	not applicable		
IEC/EN 60947-2 DIN VDE 0660 8/69 Part 101		$1.05 \cdot I_n$	$1.2 \cdot I_n$	$> 2 \text{ h}$ $< 1 \text{ h}$ ③ $< 2 \text{ min.}$ ③ $> 2 \text{ s (T1)}$	$10 \cdot I_n$	$14 \cdot I_n$	$> 0.2 \text{ s}$ $< 0.2 \text{ s}$
DIN VDE 0660/9.82	Z 0.5 to 63 A	$1.05 \cdot I_n$	$1.2 \cdot I_n$	$> 1 \text{ h}$ $< 1 \text{ h}$	not applicable		
IEC/EN 60947-2 DIN VDE 0660 8/69 Part 101		$1.05 \cdot I_n$	$1.2 \cdot I_n$	$> 2 \text{ h}$ $< 1 \text{ h}$ ③ $< 2 \text{ min.}$ ③ $> 2 \text{ s (T1)}$	$2 \cdot I_n$	$3 \cdot I_n$	$> 0.2 \text{ s}$ $< 0.2 \text{ s}$

① The indicated tripping values of electromagnetic tripping devices apply to a frequency range of 16 2/3...60 Hz. In the case of diverging frequencies or direct current, see paragraph "Variation of tripping threshold of MCBs, according to network frequency" (page 6/7)

② The thermal releases are calibrated to a nominal reference ambient temperature; for Z and K, the value is 20 °C, for B and C = 30 °C. In the case of higher ambient temperatures, the current values fall by ca. 6 % for each 10 K temperature rise.

③ As from operating temperature (after $I_1 > 1 \text{ h}$ or, as applicable, 2 h).

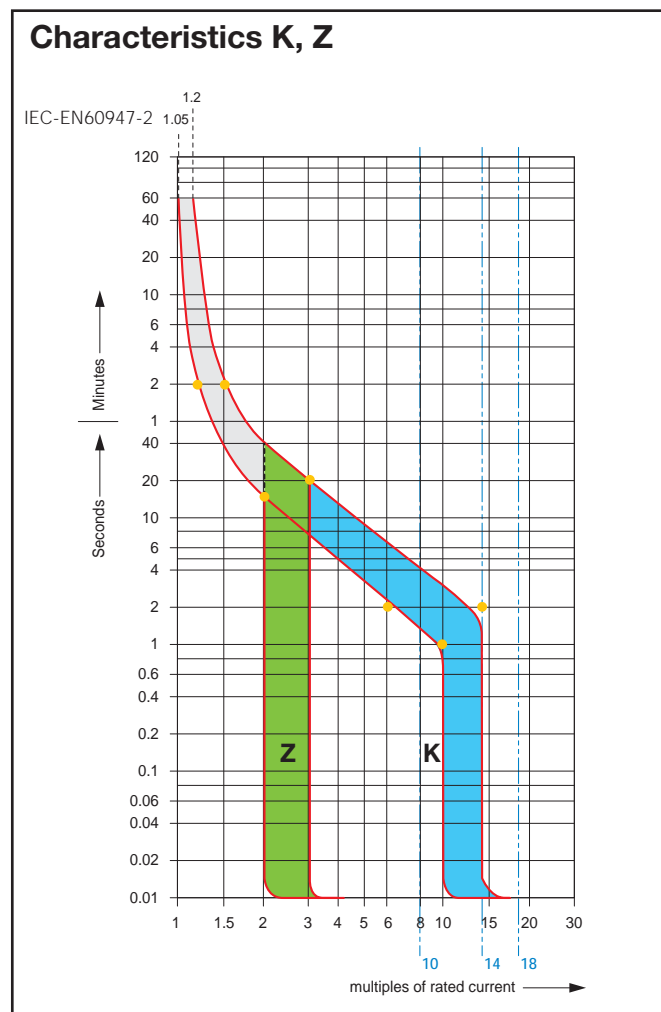
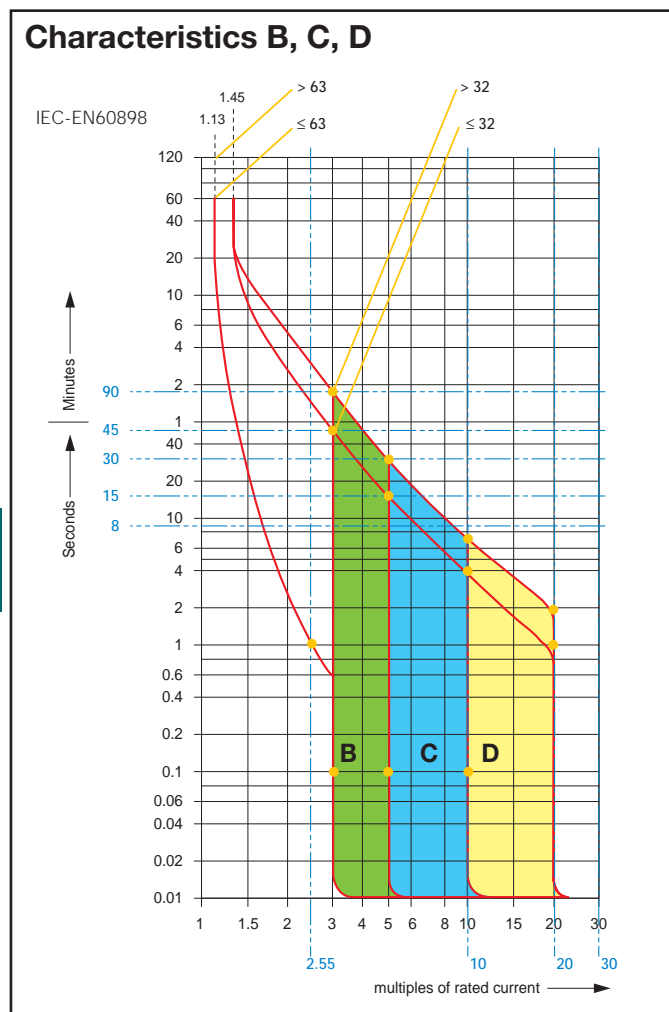

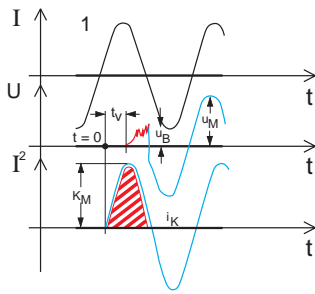

Non-current limiting circuit-breaker

Oscillogram of short-circuit breaks on two circuit-breakers:

- 1** = traditional non-current limiting circuit-breaker
- 2** = current limiting circuit-breaker
- u_B = arc voltage (red)
- u_M = rest voltage (blue)

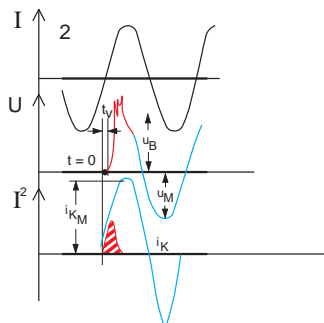

Current limiting circuit-breaker

Short-circuit current

- red** = effective short-circuit current squared
- blue** = estimated short-circuit current squared (shunted circuit-breaker)
- i_{K_M} = maximum values of symmetrical component of short-circuit current squared
- shaded in red** = specific let-through energy in two cases

Limitation of specific let-through energy

Tripping of an installation circuit by circuit-breaker when there is a short-circuit requires a certain amount of time depending on the characteristics of the circuit-breaker and the entity of the short-circuit current. During this period of time, some or all of the short-circuit current flows into the installation; the parameter I^2t defines the "specific let-through energy", ie. the specific energy that the breaker allows through when there is a short-circuit current I_{cc} during the tripping time t .

In this way, we can determine the capacity of a circuit-breaker to limit, ie. break high currents up to the rated breaking power of the device, by reducing the peak value of the above-mentioned currents to a value which is considerably lower than the estimated current.

This can be achieved using mechanisms which open very rapidly and have the following advantages:

- they limit the thermal and dynamic effects both on the circuit-breaker and on the protected circuit;
- they reduce the dimensions of the current-limiting circuit-breaker without reducing breaking capacity;
- they considerably reduce ionized gases and sparklers emitted during the short-circuit and therefore they avoid the danger of ignition and fires.

i_{rms} = perspective symmetrical short-circuit current

Max. withstanding specific let-through energy of cables

Section mm²	PVC	EPR	HEPR
50	33,062,500	39,062,500	51,122,500
35	16,200,625	19,140,625	25,050,025
25	8,265,625	9,765,625	12,780,625
16	3,385,600	4,000,000	5,234,944
10	1,322,500	1,562,500	2,044,900
6	476,100	562,500	736,164
4	211,600	250,000	327,184
2.5	82,656	97,656	127,806
1.5	29,756	35,156	46,010

The selection of the cables depends both from the breakers' specific let-through energy and from carrying capacity and voltage drop of the line.

Data of the previous table are referred to the following cables:

PVC	EPR	HEPR
FM9	H07RN-F	N07G9-K
FM9OZ1		FTG100M1
N07V-K		RG7OR
FROR		FG7OM1
		FG7OR

Designation

Cable's reference to the standards	harmonized	H
	national cable recognized by CENELC	A
Rated voltage U_0/U	100/100 ≤ U_0/U < 300/300	01
	300/300 V	03
	300/500 V	05
	450/750 V	07
	750/1000 V	1
Insulating materials and non-metallic sheath	ethylene-vinylacetate	G
	mineral	M
	polyvinyl chloride	V
Conductor's shape	flexible conductor of a cable for fixed installation	K

Some cables on the market are identified with different names according with the designation UNEL 35011.

I^2t diagrams - Specific let-through energy value I^2t

The I^2t curves give the values of the specific let-through energy expressed in A^2s (A=amps; s=seconds) in relation to the perspective short-circuit current (I_{rms}) in kA.

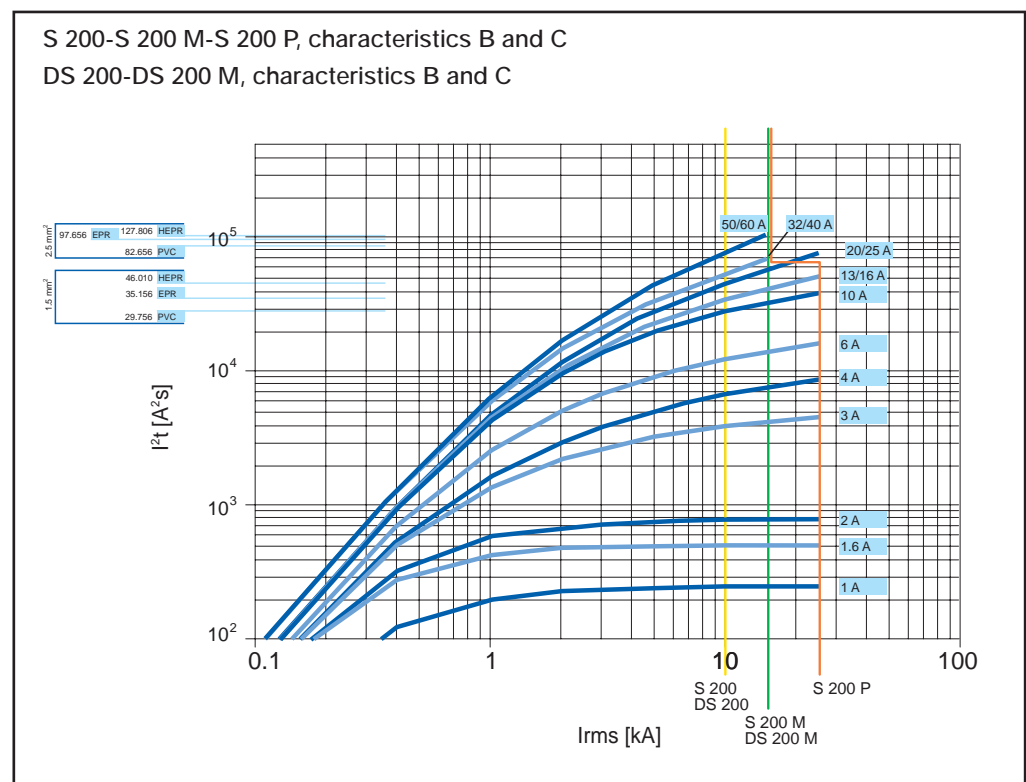
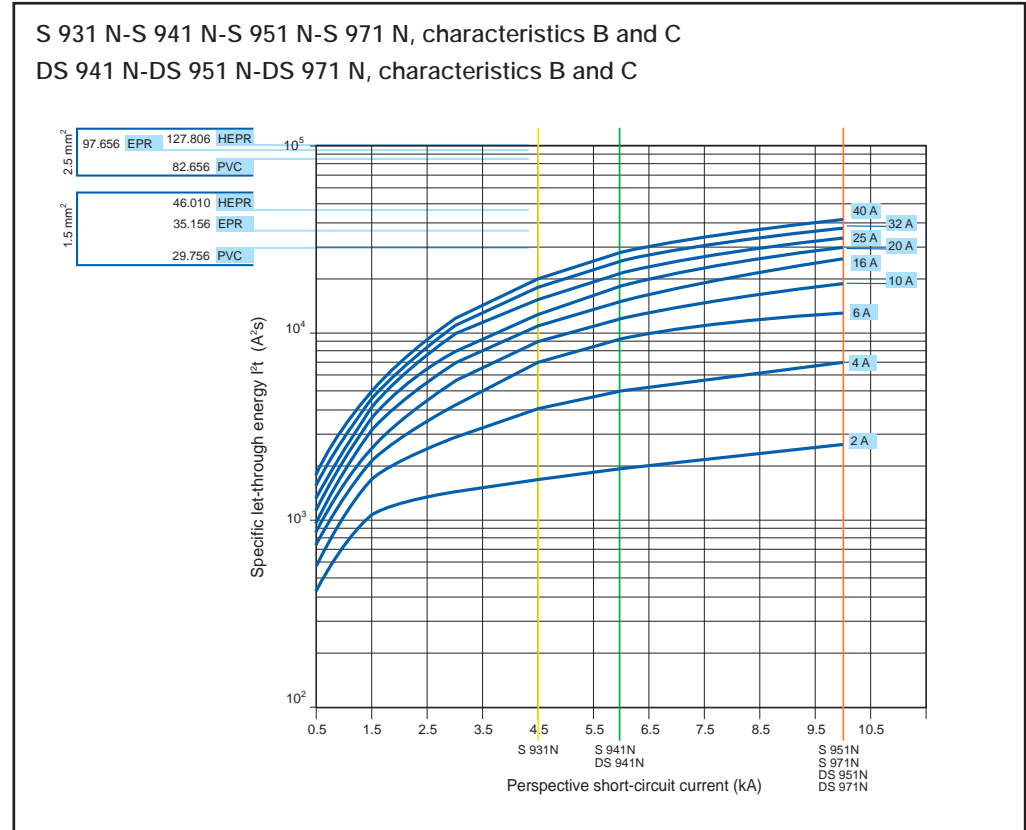

For further information about the selection of the cable, please look at the table in page 11/3

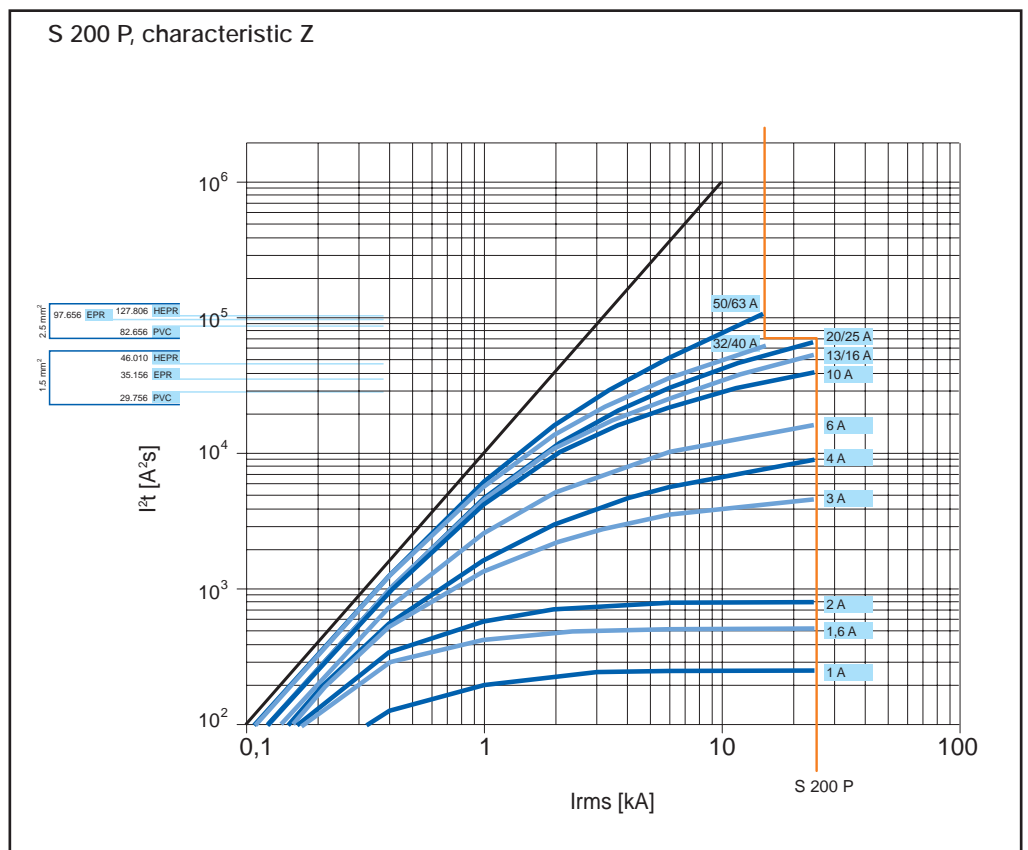
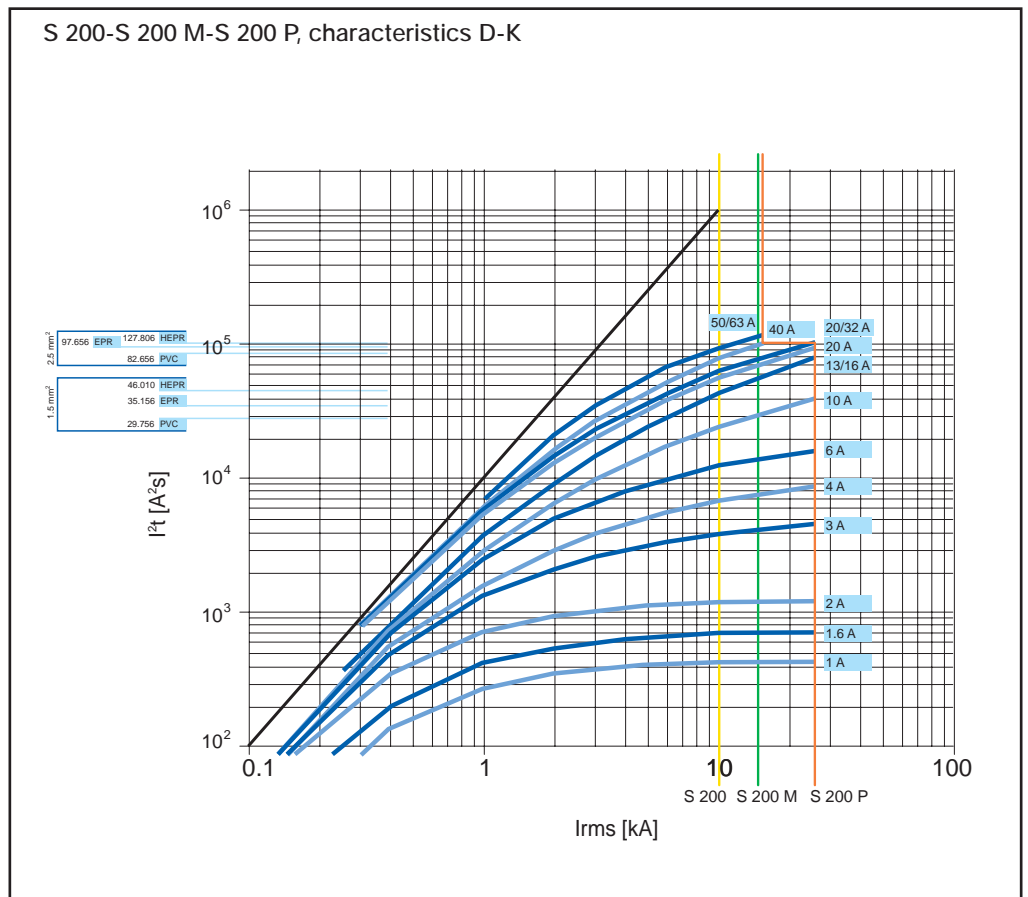

For further information about the selection of the cable, please look at the table in page 11/3

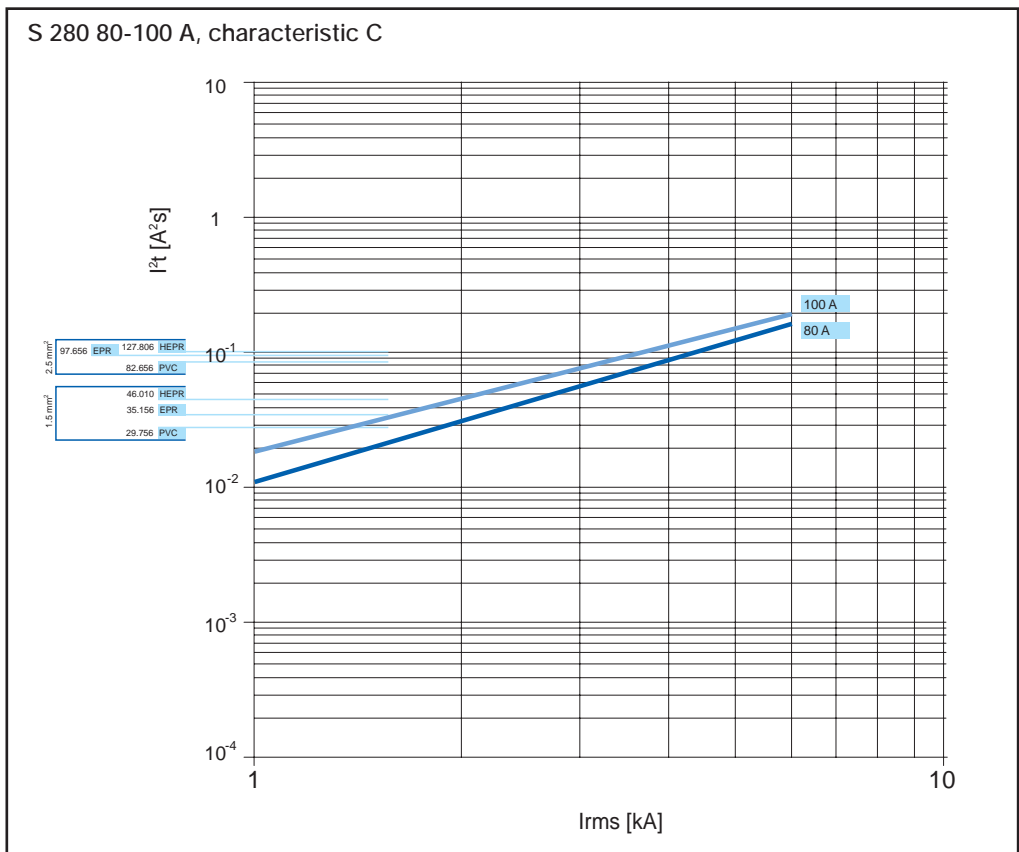
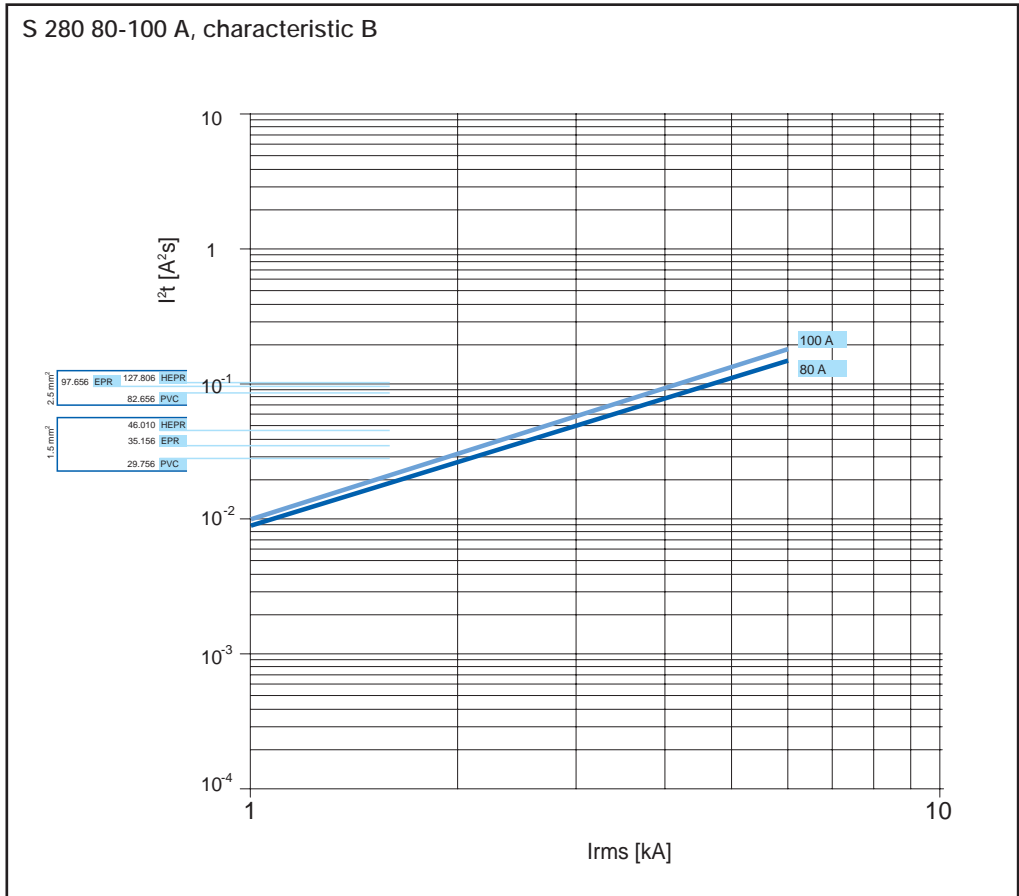

For further information about the selection of the cable, please look at the table in page 11/3

S 280 characteristics K, Z

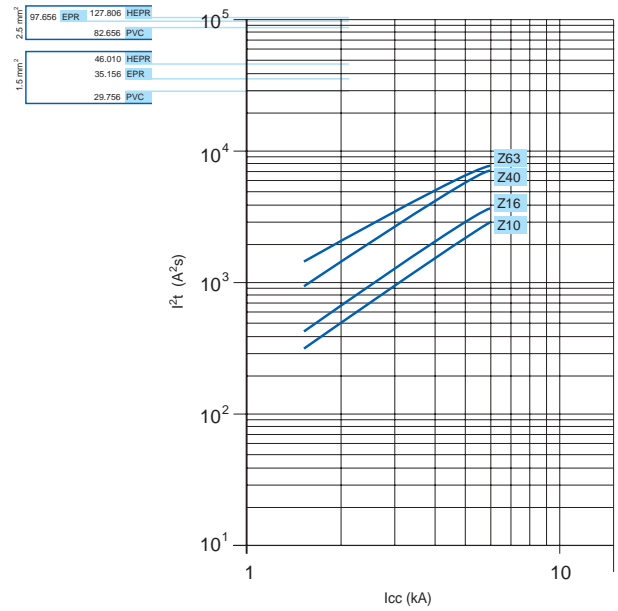

S 290 characteristics C, D

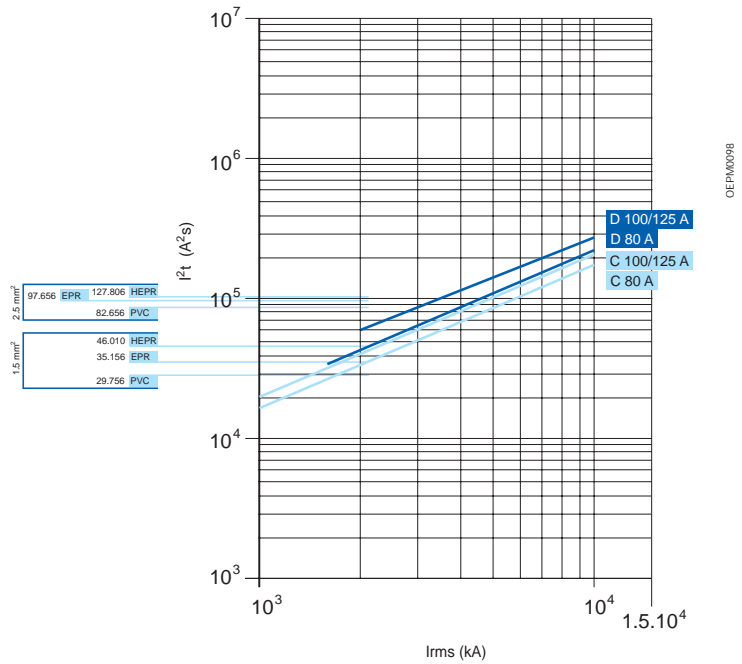

For further information about the selection of the cable, please look at the table in page 11/3

S800 S characteristics B, C, K and D

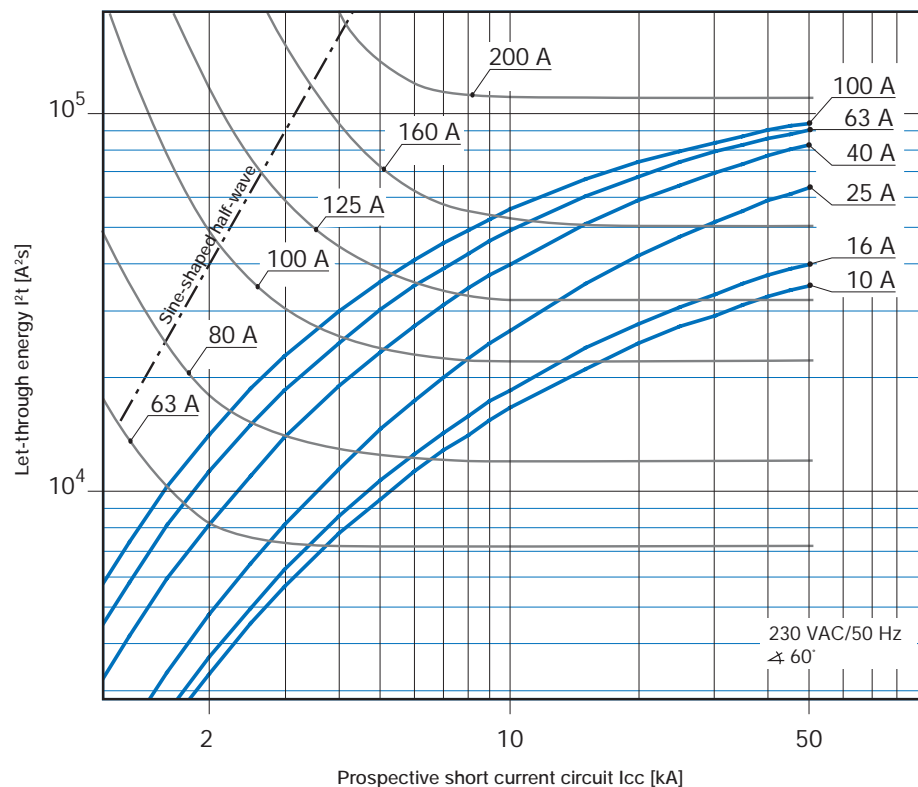
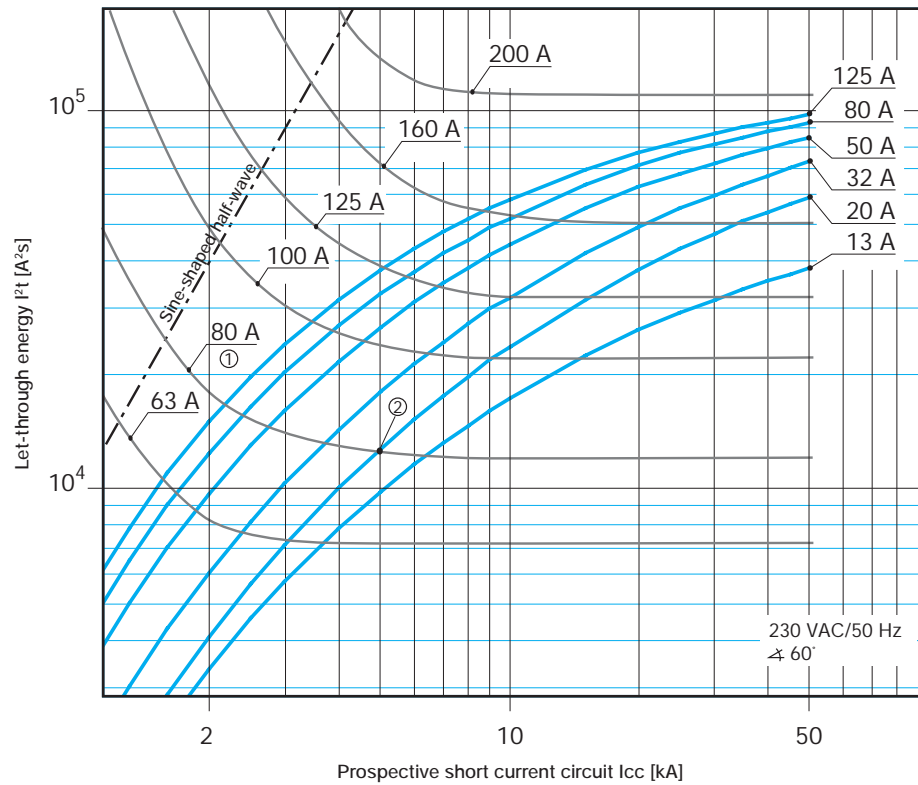

① Min. pre-arcing I^2t , e.g. NH80 A gL/gG
② Max. let-through I^2t , e.g. S801S-C20

S800 N characteristics B, C and D

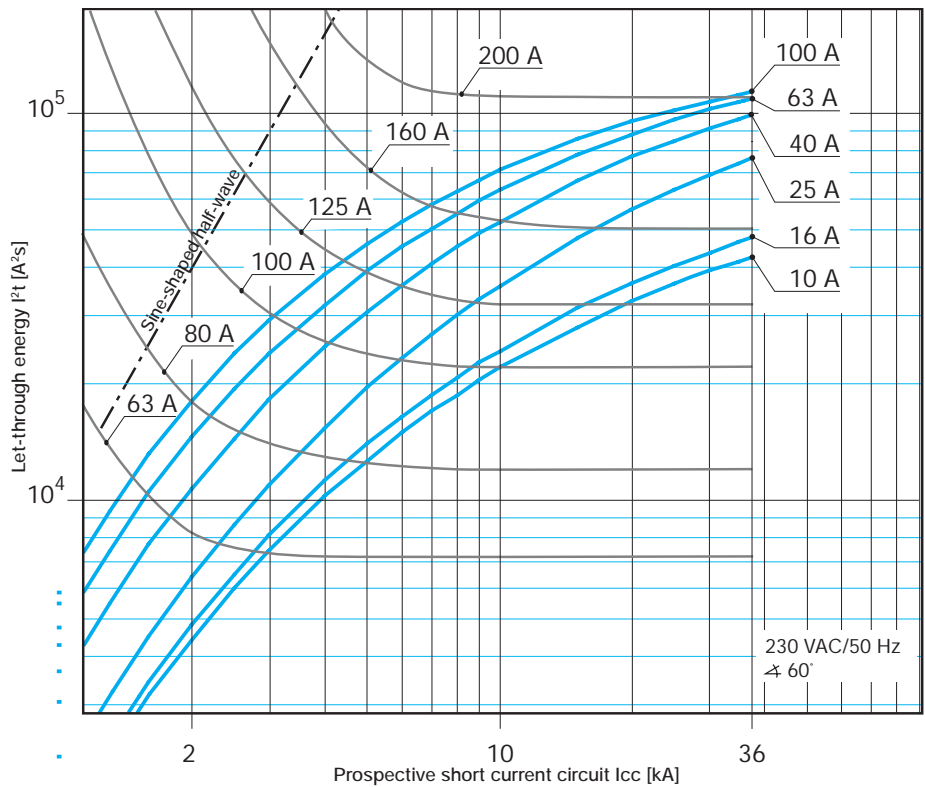
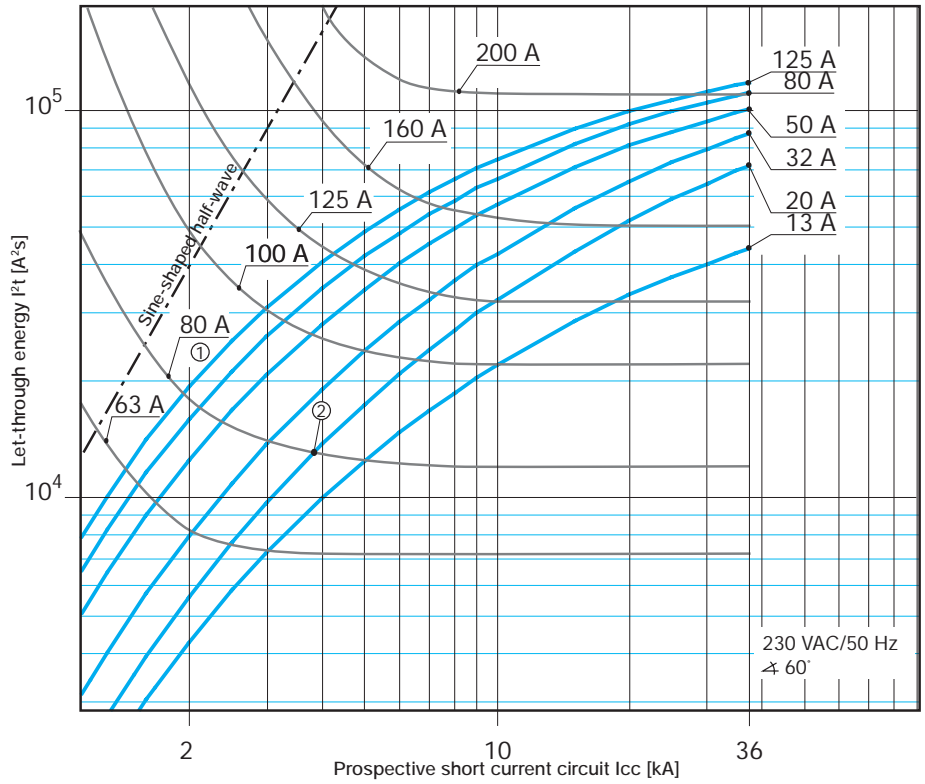

① Min. pre-arching I^2t , e.g. NH80 A gL/gG
② Max. let-through I^2t , e.g. S801S-C20

Limitation curves - Peak current values

The I_p curves give the values of the peak current, expressed in kA, in relation to the perspective symmetrical short-circuit current (kA).

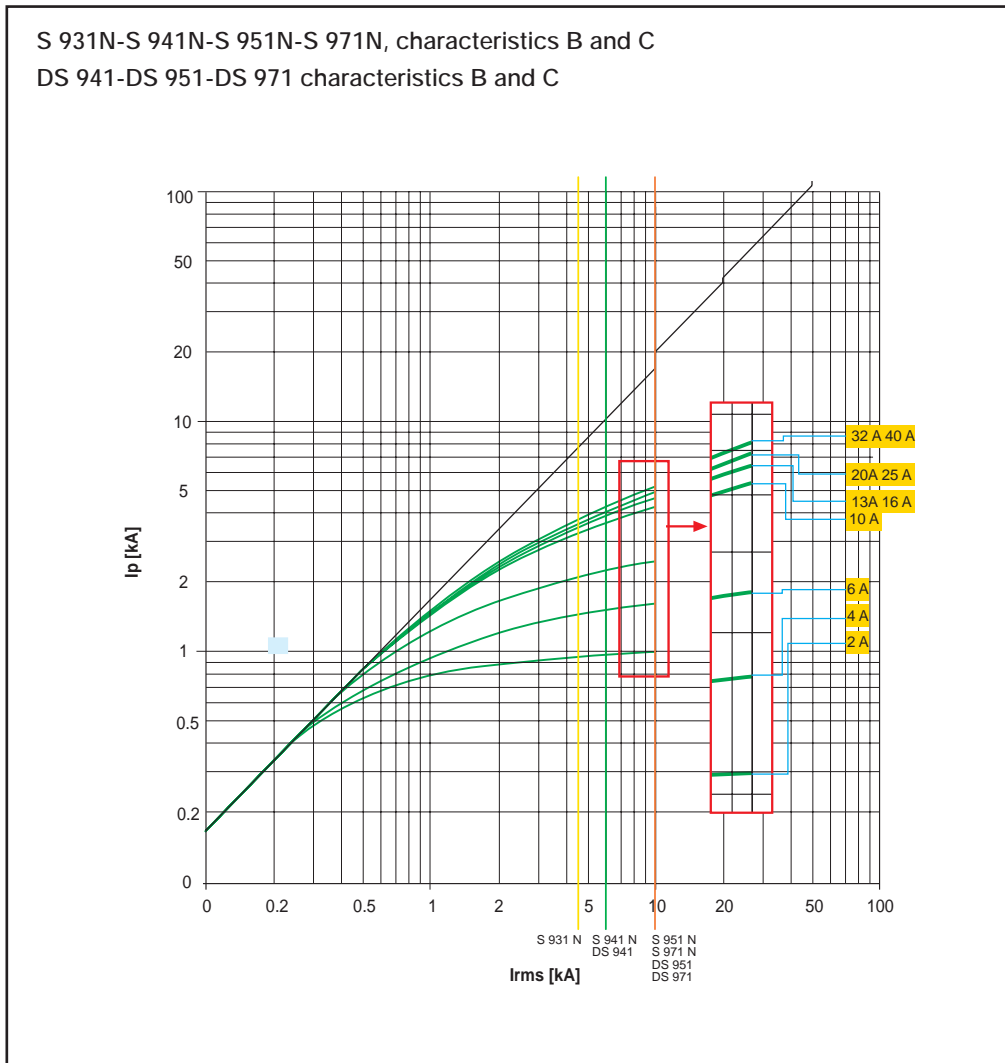

S 200-S 200 P, characteristics B-C
DS 200-DS 200 M, characteristics B-C

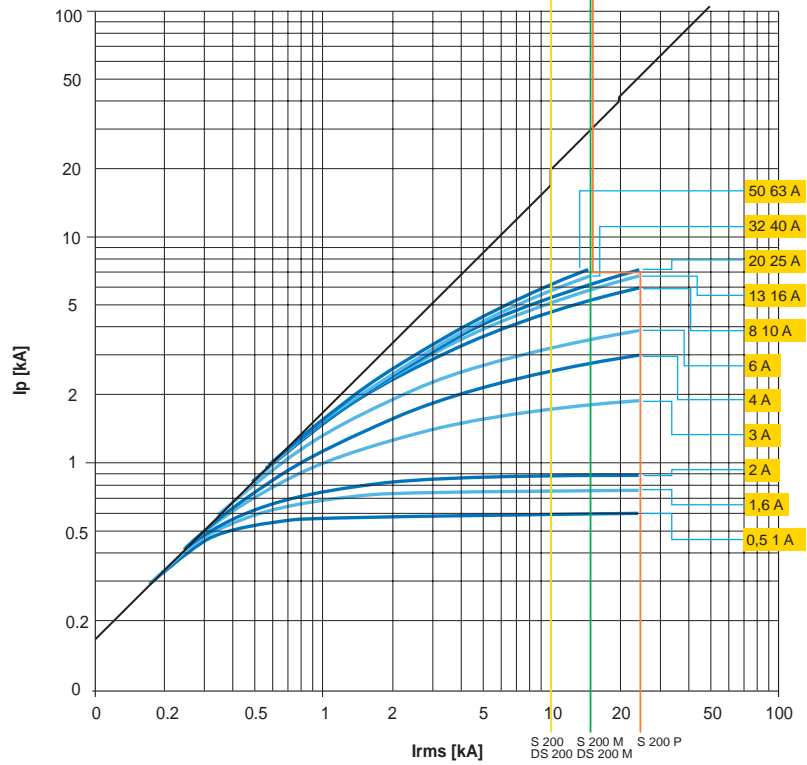

S 200-S 200 P, characteristics K-D

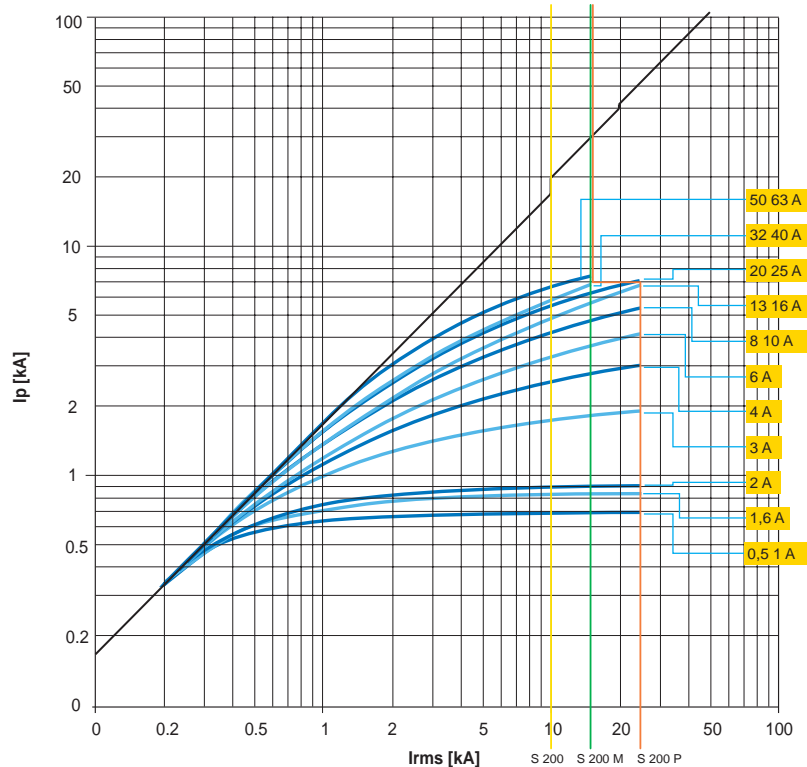

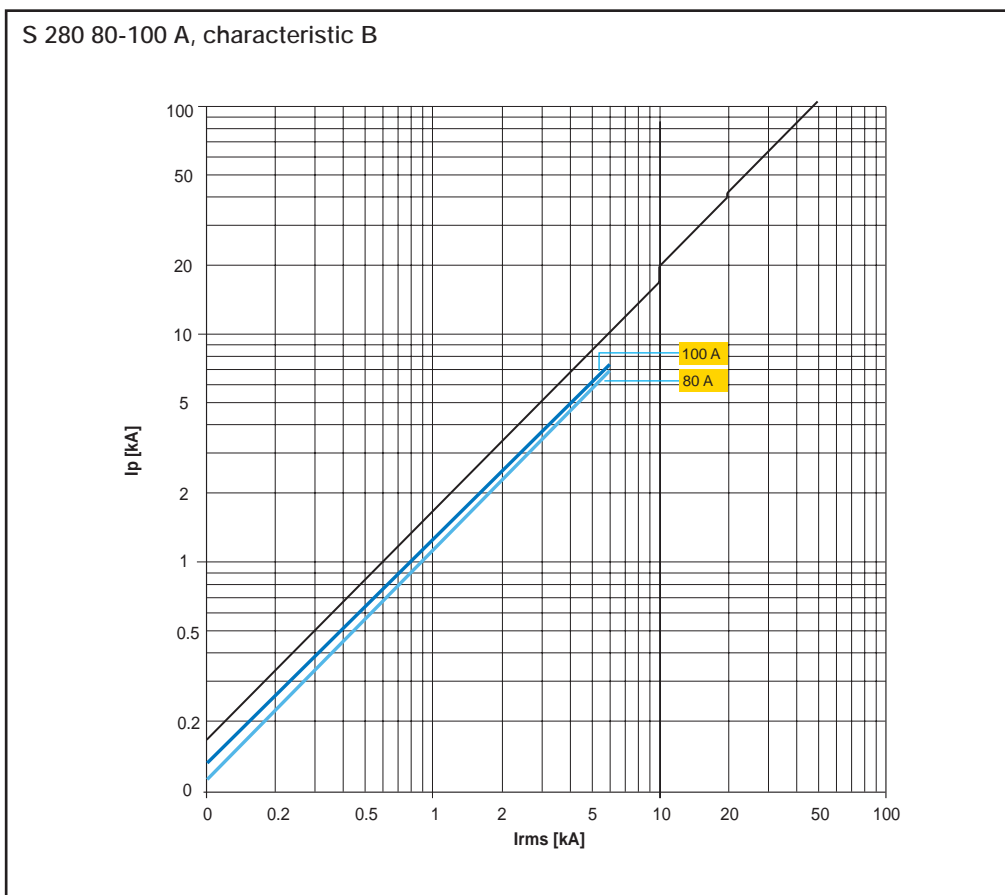
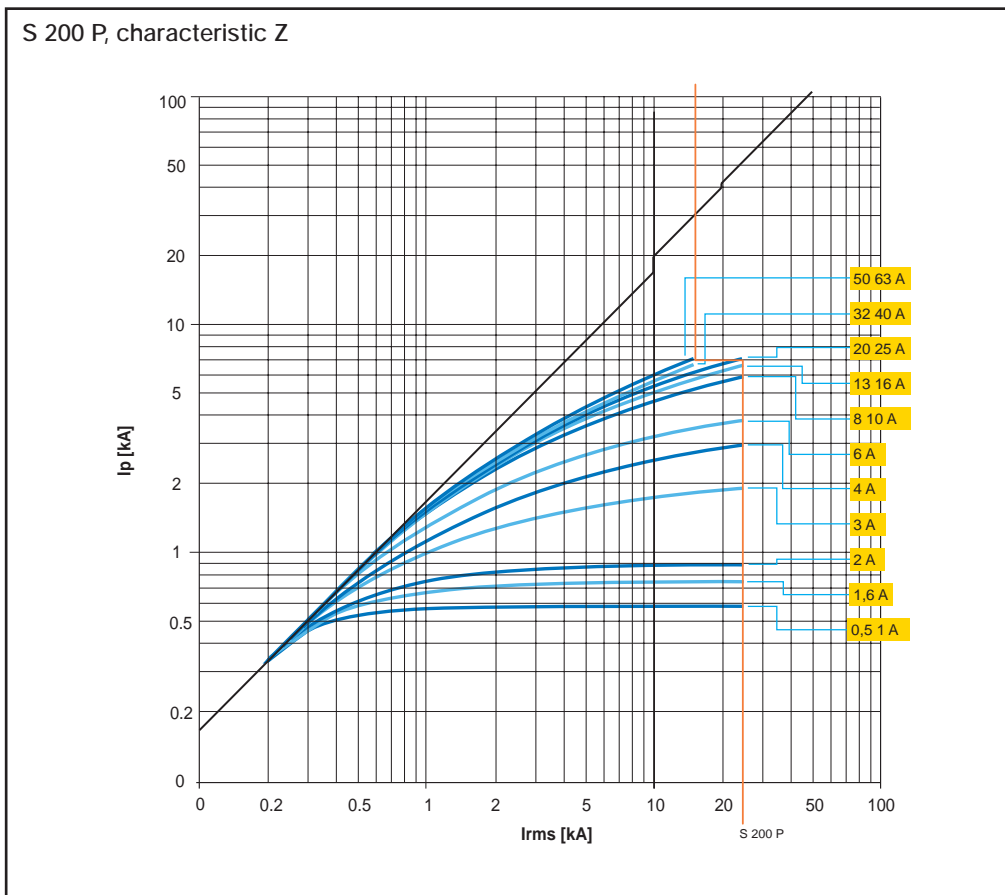

S 280 80-100 A, characteristic C

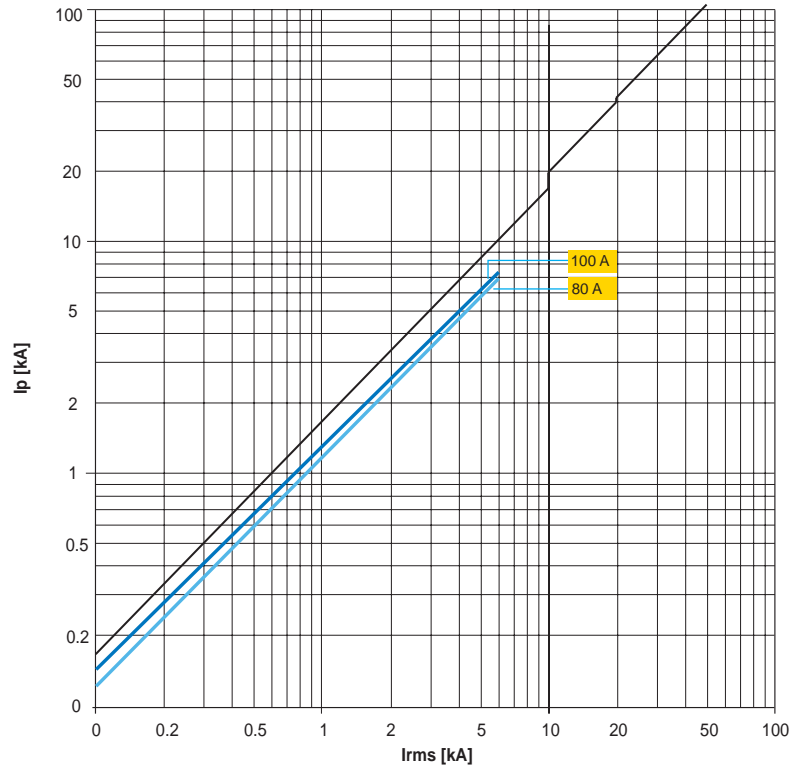

S 800 S characteristics B, C, K and D

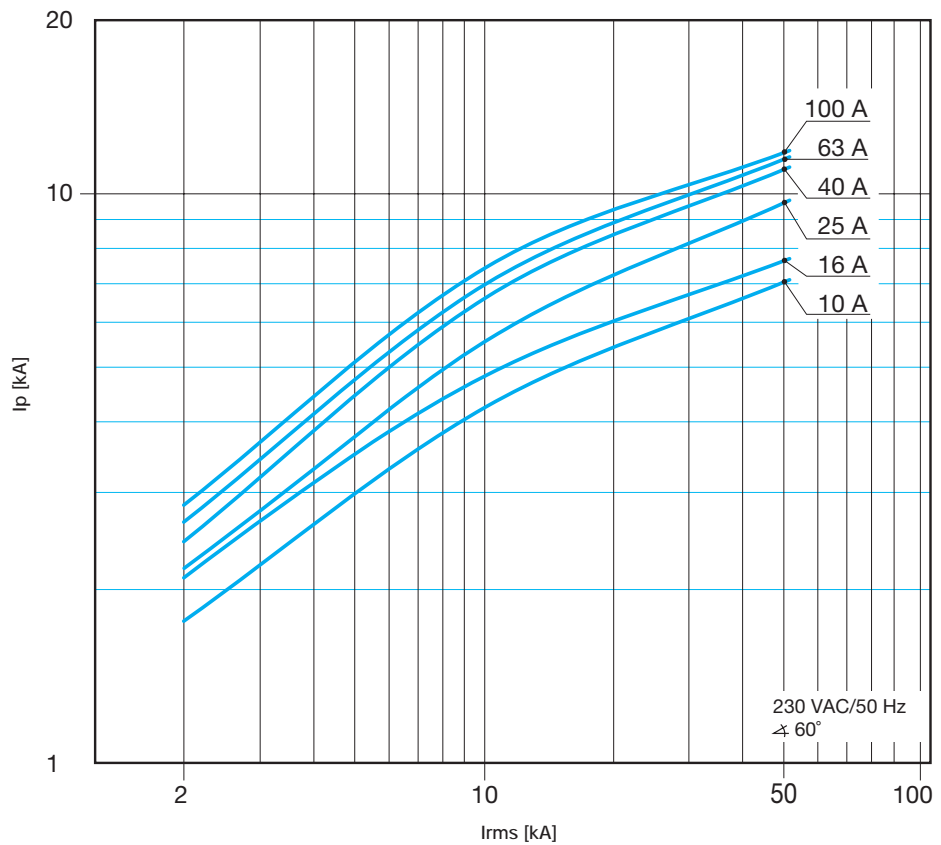
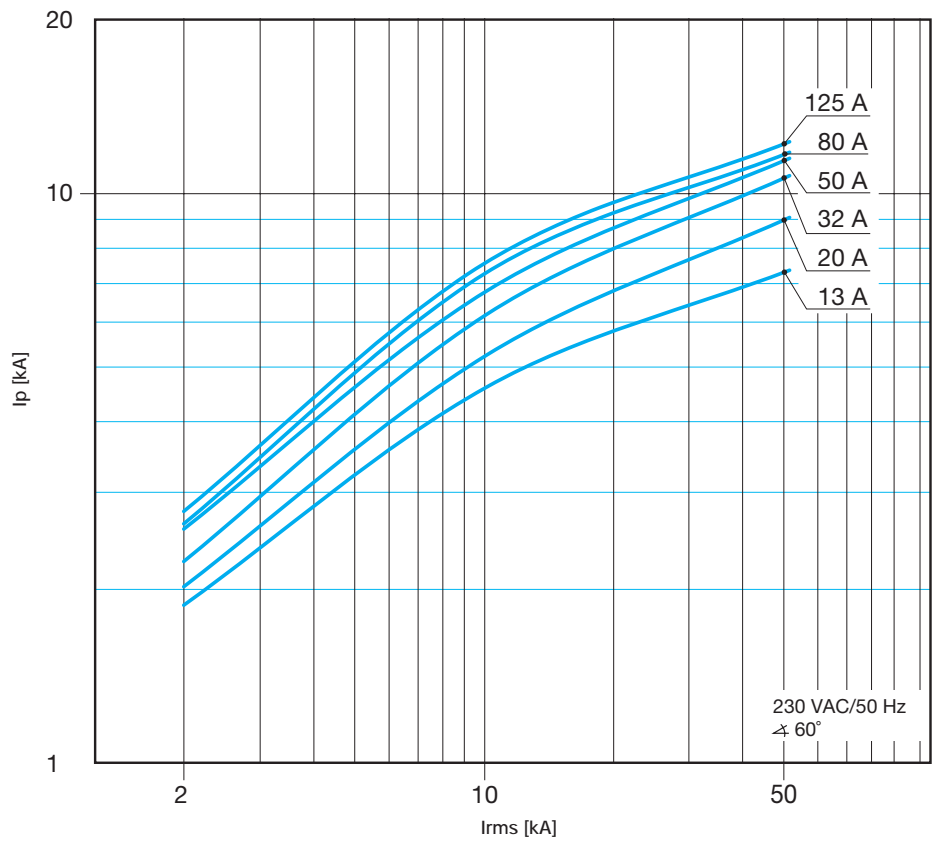

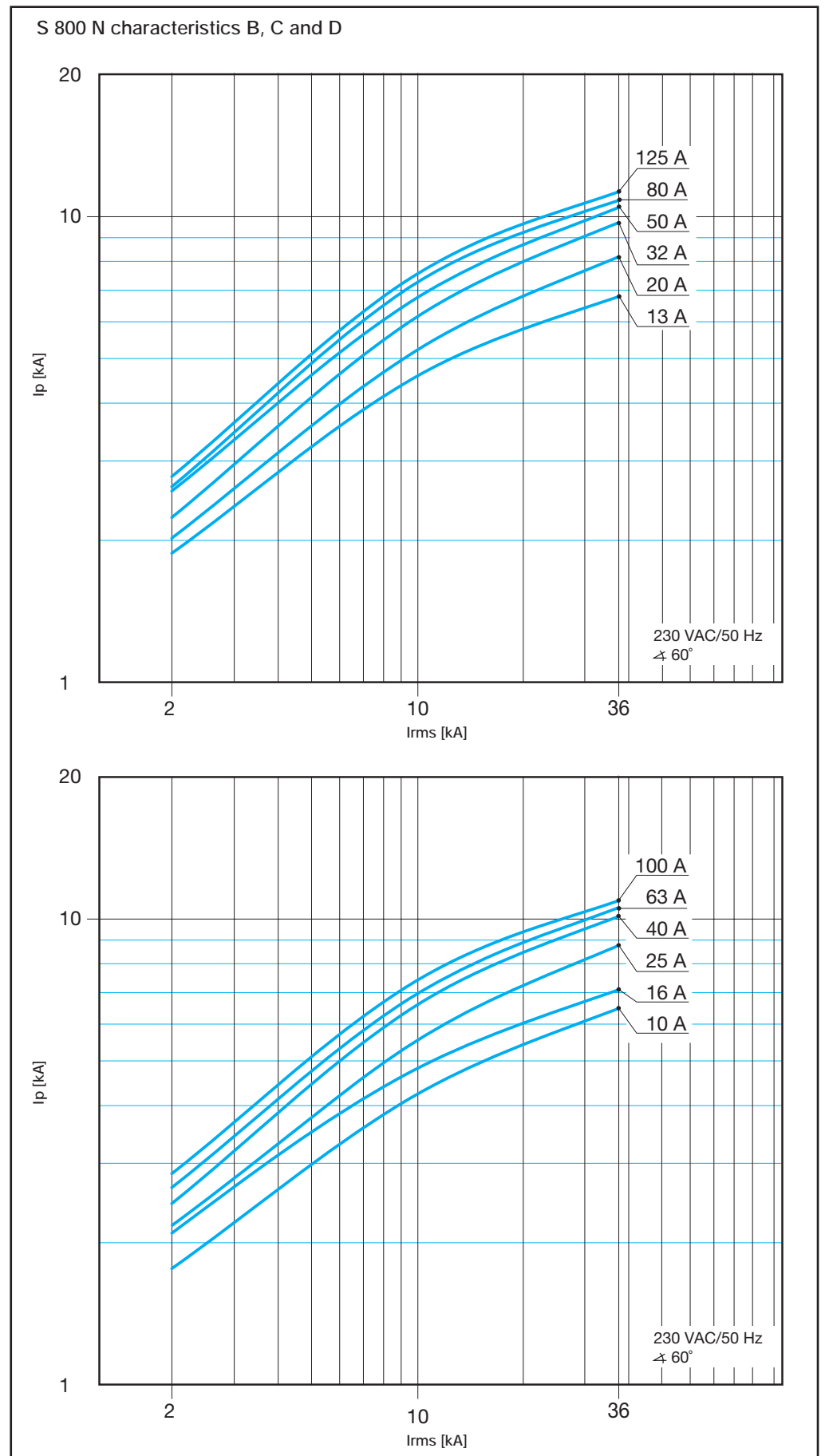

Back-up protection

The tables given provide the value (in kA, referring to the breaking capacity according to the IEC 60947-2 Standard) for which the back-up protection among the combination of selected circuit-breakers is verified. The tables cover the possible combinations between ABB SACE Tmax series of moulded-case circuit-breakers and those between the above-mentioned circuit-breakers and the ABB series of modular circuit-breakers.

The values indicated in the tables refer to the voltage:

- Vn of 230/240 V AC for coordination with modular S9 circuit-breakers
- Vn of 400/415 V AC for all the other coordinations.

Selective protection

The tables given provide the value (in kA, referring to the breaking capacity according to the IEC 60947-2 Standard) for which the selective protection is verified among the combination of selected circuit-breakers. The tables cover the possible combinations between ABB SACE Tmax series of moulded-case circuit-breakers, and the ABB series of modular circuit-breakers. The values in the table represent the maximum value obtainable of discrimination between supply side circuit-breaker and load side circuit-breaker referring to the voltage:

- Vn of 230/240 V AC for the S9 circuit-breakers and Vn of 400/415 V AC for the supply side circuit-breakers in the coordination between MCB with the modular S9 circuit-breakers (see picture).
- Vn of 400/415 V AC for all the other coordinations.

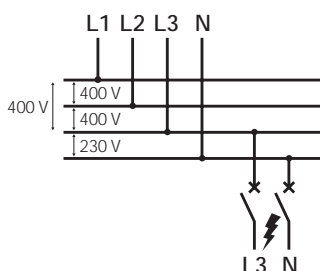

General prescriptions

- Function I of the electronic releases of the supply side circuit-breakers must be excluded (I_3 in OFF);
- The magnetic trip of thermomagnetic (TM) or magnetic only (M) circuit-breakers placed on the supply side must be $10 \times I_n$ and regulated to the maximum threshold;
- It is of prime importance to check that the settings made by the user for the electronic and thermomagnetic relays of circuit-breakers placed both on the load and supply side do not create intersections on the time-current curves.

Note

The following tables give the breaking capacities at 415 V AC for circuit-breakers SACE Tmax.

Tmax @ 415 V AC	
Version	Icu [kA]
B	16
C	25
N	36
S	50
H	70
L (T2)	85
L (T4, T5)	120
V	200

Caption

MCB = miniature circuit-breakers (S 9, S 2, S 800)
 MCCB = moulded-case circuit-breakers (Tmax)

- MF (Tmax)
- MA (Tmax)
- EL = electronic release
- PR221DS - PR222DS (Tmax)

For moulded-case or air circuit-breakers:

- TM = thermomagnetic release
 - TMD (Tmax)
 - TMA (Tmax)
- M = magnetic only release

For miniature circuit-breakers:

- B = trip characteristic ($I_m=3...5I_n$)
- C = trip characteristic ($I_m=5...10I_n$)
- D = trip characteristic ($I_m=10...20I_n$)
- K = trip characteristic ($I_m=8...14I_n$)
- Z = trip characteristic ($I_m=2...3I_n$)

For solutions not shown in these tables, please consult the website:

<http://bol.it.abb.com> or contact ABB SACE

System pro M compact®

Technical details

Coordination tables: back-up

MCBs

MCB - MCB @240 V

Load s.	Char.	In [A]	Icu [kA]	Supply s.											
				S200	S200M	S200P	S200P	S290	S800S	25gL	40gL	50gL	63gL	80gL	100gL
				B-C	B-C	B-C	B-C	C	B-C-D-K						
				20	25	40	25	25	50						
				0,5...63	0,5...63	0,5...25	32...63	80...125	10...125						
S 931 N	C	4,5	2...40	20	25	40	25	15	50						
S 941 N/ DS 941	B,C	6	2...40	20	25	40	25	15	50	35	25	20	15	10	10
S 951 N/ DS 951	B,C	10	2...40	20	25	40	25	15	50	35	25	20	15	10	10
S 971 N/ DS 971	B,C	10	2...40	20	25	40	25	15	50	35	25	20	15	10	10
S 200	B,C,K,Z	20	0,5...63		25	40	25		50						
S 200 M	B,C,D	25	0,5...63			40			50						
S 200 P	B,C	40	0,5...25						50						
	D,K,Z	25	32...63						50						
S 290	C,D,K	25	80,125												
S 800	B,C	100	10...125												

MCCB @415 V - MCB @240 V

Load s.	Char.	In [A]	Icu [kA]	Supply s.*											
				T1	T1	T1	T2	T3	T2	T3	T2	T2			
				Version B	Version C	Version N	Version N	Version N	Version S	Version S	Version H	Version L			
				16	25	36	36	36	50	50	70	85			
S 931 N	C	2..25	4,5	16	16	16	20	10	20	10	20	20			
		32,40	4,5	10	10	10	16	10	16	10	16	16			
S 941 N	B,C	2..25	6	16	16	16	20	10	20	10	20	20			
		32,40	6	10	10	10	16	10	16	10	16	16			
S 951 N	B,C	2..25	10	16	16	16	25	16	25	16	25	25			
		32,40	10	16	16	16	16	16	16	16	16	16			
S 971 N	B,C	2..25	10	16	16	16	25	16	15	16	25	25			
		32,40	10	16	16	16	16	16	16	16	16	16			

*Supply side circuit-breaker 4P (load side circuit branched between one phase and the neutral)

MCB - MCB @415 V

Load s.	Char.	In [A]	Icu [kA]	Supply s.									
				S200	S200M	S200P	S200P	S 280	S 290	S 800 S	S 800 N		
				B-C	B-C	B-C	B-C	B-C	C	B-C-D-K	B-C-D		
				10	15	25	15	6	20	50	36		
				0,5..63	0,5..63	0,5..25	32..63	80,100	80..125	10..125	10..125		
S 200	B,C,K,Z	10	0,5..63		15	25	15		15	50	36		
S 200 M	B,C,D	15	0,5..63			25				50	36		
S 200 P	B,C,	25	0,5..25							50	36		
	D,K,Z	15	32..63							50	36		
S 280	B,C	6	80,100										
S 290	C,D,K	20 (15)*	80..125										

MCCB - MCB @415 V

Load s.	Char.	In [A]	Icu [kA]	Supply s.														
				T1	T1	T1	T2	T3	T4	T2	T3	T4	T2	T4	T2	T4	T4	
				Version B	Version C	Version N	Version N	Version N	Version N	Version S	Version S	Version S	Version H	Version H	Version L	Version L	Version V	
				16	25	36	36	36	36	50	50	50	70	70	85	120	200	
S 200	B,C,K,Z	0,5..10	10	16	25	30	36	36	36	36	40	40	40	40	40	40	40	
		13..63	10	16	25	30	36	16	36	36	16	40	40	40	40	40	40	
S 200 M	B,C,D	0,5..10	15	16	25	30	36	36	36	50	40	40	70	40	85	40	40	
		13..63	15	16	25	30	36	25	36	50	60	40	60	40	60	40	40	
S 200 P	B,C,	0,5..10	25			30	36	36	36	50	40	40	70	40	85	40	40	
	D,K,Z	13..25	25			36	30	36	50	30	40	60	40	60	40	40	40	
		32..63	15	16	25	30	36	25	36	50	25	40	60	40	60	40	40	
S 280	B,C	80,100	6	16	16	16	36	16	30	36	16	30	36	30	36	30	30	
S 290	C,D,K	80..125	20 (15)*	16	25	30	36	30	30	50	30	30	70	30	85	30	30	
S 800 S	B,C,D,K	10..125	50										70	70	85	120	200	
S 800 N	B,C,D	10..125	36										70	70	85	120	200	

*Only for D characteristic

Selective protection

Selectivity between S 9.. and S 200 upstream and downstream modular circuit-breakers
In the case, selectivity is amperometric and so the selectivity limit is given simply by the magnetic threshold of the upstream breaker, which is fixed. The selectivity value is obtained if a minimum ratio of 1.6 (In upstream/In downstream > 1.6) is observed between the rated currents of the two breakers.

Example

Upstream circuit-breaker	S 200 P, curve D 50 A
Downstream circuit-breaker	S 941 N, curve B 10 A
Selectivity limit	10 In=500 A

MCB -S9 @230/240 V

		Supply s. **		S290					
		Char.	C			D			
		Icu [kA]	25						
Load s. *		In [A]	80	100	125	80	100		
S931N	B-C	4.5	2	T	T	T	T	T	
			4	T	T	T	T	T	
			6	T	T	T	T	T	
			10	4	T	T	T	T	
			16	2.5	3.5	3.5	4	T	
			20	1.5	2.5	2.5	3	T	
			25	0.5	0.5	1.5	2	4	
			32	0.5	0.5	0.5	1.5	3.5	
			40	0.5	0.5	0.5	1.5	3.5	
S941N	B-C	6	2	T	T	T	T	T	
			4	5	T	T	T	T	
			6	4.5	5	T	5.5	T	
			10	4	4.5	5	5	5	
			16	2.5	3.5	3.5	4	4.5	
			20	1.5	2.5	2.5	3	4.5	
			25	0.5	0.5	1.5	2	4	
			32	0.5	0.5	0.5	1.5	3.5	
			40	0.5	0.5	0.5	1.5	3.5	
S951N	B-C	10	2	6	8	9	7	8	
			4	5	6	7.5	6	7	
			6	4.5	5	6	5.5	6	
			10	4	4.5	5	5	5	
			16	2.5	3.5	3.5	4	4.5	
			20	1.5	2.5	2.5	3	4.5	
			25	0.5	0.5	1.5	2	4	
			32	0.5	0.5	0.5	1.5	3.5	
			40	0.5	0.5	0.5	1.5	3.5	
S971N	B-C	10	2	6	8	9	7	8	
			4	5	6	7.5	6	7	
			6	4.5	5	6	5.5	6	
			10	4	4.5	5	5	5	
			16	2.5	3.5	3.5	4	4.5	
			20	1.5	2.5	2.5	3	4.5	
			25	0.5	0.5	1.5	2	4	
			32	0.5	0.5	0.5	1.5	3.5	
			40	0.5	0.5	0.5	1.5	3.5	

*Load side circuit-breaker 1P+N (230/240 V)

**For networks with 230/240 V AC ->two-pole circuit-breaker (phase +neutral)

for networks at 400/415 V AC ->four-pole circuit-breaker (load side circuit branched between one phase and the neutral)

MCB - S 200 @ 400/415 V

		Supply s.		S 290	
		Char.		D	
		Icu [kA]		15	
Load s.		In [A]	80	100	
S 200	C	10	≤ 2	T	T
			3	T	T
			4	T	T
			6	T	T
	B-C	10	8	T	T
			10	5	8
			13	4.5	7
			16	4.5	7
			20	3.5	5
			25	3.5	5
			32		4.5
			40		
			50		
			63		
	D	10	≤ 2	T	T
			3	T	T
			4	T	T
			6	T	T
			8	T	T
			10	5	8
			13	3	5
			16	3	5
			20	3	5
			25		4
			32		
			40		
			50		
	63				
	K	10	≤ 2	T	T
			3	T	T
			4	T	T
			6	T	T
			8	T	T
10			5	8	
16			3	5	
20			3	5	
25				4	
32					
40					
50					
63					
Z	10	≤ 2	T	T	
		3	T	T	
		4	T	T	
		6	T	T	
		8	T	T	
		10	5	8	
		16	4.5	7	
		20	3.5	5	
		25	3.5	5	
		32	3	4.5	
		40	3	4.5	
		50		3	
		63			

Fuse

	Im	Icu [kA]	In [A]								
			25	32	40	50	63	80	100	125	
S931N	C	4.5	2	1.5	2.5	T	T	T	T	T	T
		4.5	4	1	2	T	T	T	T	T	T
		4.5	6	1	1.5	4	T	T	T	T	T
		4.5	10	-	1.2	3.5	4	T	T	T	T
		4.5	16	-	1	3	3.5	T	T	T	T
		4.5	20	-	1	3	3.5	T	T	T	T
		4.5	25	-	1	2	3	T	T	T	T
		4.5	32	-	1	2	3	T	T	T	T
		4.5	40	-	-	1.5	2.5	4	T	T	T
S941N	B-C	6	2	1.5	2.5	T	T	T	T	T	T
		6	4	1	2	4.5	T	T	T	T	T
		6	6	1	1.5	4	4.5	T	T	T	T
		6	10	-	1.2	3.5	4	T	T	T	T
		6	16	-	1	3	3.5	5	T	T	T
		6	20	-	1	3	3.5	5	T	T	T
		6	25	-	1	2	3	4.5	T	T	T
		6	32	-	1	2	3	4.5	5	T	T
		6	40	-	-	1.5	2.5	4	5	T	T
S951N	B-C	10	2	1.5	2.5	5	T	T	T	T	T
		10	4	1	2	4.5	5	T	T	T	T
		10	6	1	1.5	4	4.5	7	T	T	T
		10	10	-	1.2	3.5	4	6	T	T	T
		10	16	-	1	3	3.5	5	T	T	T
		10	20	-	1	3	3.5	5	8	T	T
		10	25	-	1	2	3	4.5	6.5	T	T
		10	32	-	1	2	3	4.5	5	8	T
		10	40	-	-	1.5	2.5	4	5	6.5	T
S971N	B-C	10	2	1.5	2.5	5	7	T	T	T	T
		10	4	1	2	4.5	5	8	T	T	T
		10	6	1	1.5	4	4.5	7	T	T	T
		10	10	-	1.2	3.5	4	6	T	T	T
		10	16	-	1	3	3.5	5	9	T	T
		10	20	-	1	3	3.5	5	8	T	T
		10	25	-	1	2	3	4.5	6.5	9	T
		10	32	-	1	2	3	4.5	5	8	T
		10	40	-	-	1.5	2.5	4	5	6.5	9

MCB S 700

		Im		E	E	E	E	E	E	E	E
			Icu [kA]	30	30	30	30	30	30	30	30
			In [A]	20	25	35	40	50	63	80	100
S931N	C	4.5	2	T	T	T	T	T	T	T	T
	C	4.5	4	T	T	T	T	T	T	T	T
	C	4.5	6	T	T	T	T	T	T	T	T
	C	4.5	10	T	T	T	T	T	T	T	T
	C	4.5	16	-	T	T	T	T	T	T	T
	C	4.5	20	-	-	T	T	T	T	T	T
	C	4.5	25	-	-	T	T	T	T	T	T
	C	4.5	32	-	-	-	-	T	T	T	T
	C	4.5	40	-	-	-	-	-	T	T	T
S941N	B-C	6	2	T	T	T	T	T	T	T	T
	B-C	6	4	T	T	T	T	T	T	T	T
	B-C	6	6	T	T	T	T	T	T	T	T
	B-C	6	10	T	T	T	T	T	T	T	T
	B-C	6	16	-	T	T	T	T	T	T	T
	B-C	6	20	-	-	T	T	T	T	T	T
	B-C	6	25	-	-	T	T	T	T	T	T
	B-C	6	32	-	-	-	-	T	T	T	T
	B-C	6	40	-	-	-	-	-	T	T	T
S951N	B-C	10	2	T	T	T	T	T	T	T	T
	B-C	10	4	T	T	T	T	T	T	T	T
	B-C	10	6	T	T	T	T	T	T	T	T
	B-C	10	10	T	T	T	T	T	T	T	T
	B-C	10	16	-	T	T	T	T	T	T	T
	B-C	10	20	-	-	T	T	T	T	T	T
	B-C	10	25	-	-	T	T	T	T	T	T
	B-C	10	32	-	-	-	-	T	T	T	T
	B-C	10	40	-	-	-	-	-	T	T	T
S971N	B-C	10	2	T	T	T	T	T	T	T	T
	B-C	10	4	T	T	T	T	T	T	T	T
	B-C	10	6	T	T	T	T	T	T	T	T
	B-C	10	10	T	T	T	T	T	T	T	T
	B-C	10	16	-	T	T	T	T	T	T	T
	B-C	10	20	-	-	T	T	T	T	T	T
	B-C	10	25	-	-	T	T	T	T	T	T
	B-C	10	32	-	-	-	-	T	T	T	T
	B-C	10	40	-	-	-	-	-	T	T	T

MCCB @415 V 4p -S9 @240 V

Load s.	Supply s.			T1												T2						
	Char.	Icu [kA]	In [A]	B,C,N												N, S, H, L						
	Iu [A]	160	160	TMD												TMD,MA						
				16	20	25	32	40	50	63	80	100	125	160**	160	16	20	25	32	40	50	
S931N	C	4.5	4	T	T	T	T	T	T	T	T	T	T	T	T	T	T	T	T	T	T	
			6	T	T	T	T	T	T	T	T	T	T	T	T	T	T	T	T	T	T	T
			10			3	3	3	T	T	T	T	T	T	T		3*	3	3	3	T	
			16					3	T	T	T	T	T	T	T			3*	3	T		
			20					3	T	T	T	T	T	T	T			3*	3			
			25						T	T	T	T	T	T	T						3*	
			32							T	T	T	T	T	T						3*	
			40									T	T	T	T							3*
S941N	B-C	6	4	T	T	T	T	T	T	T	T	T	T	T	T	T	T	T	T	T	T	
			6	T	T	T	T	T	T	T	T	T	T	T	T	T	T	T	T	T	T	T
			10			3	3	3	4.5	T	T	T	T	T	T		3*	3	3	3	4.5	
			16					3	4.5	5	T	T	T	T	T			3*	3	4.5		
			20					3	5	6	T	T	T	T	T			3*	3			
			25						5	6	T	T	T	T	T						3*	
			32							6	T	T	T	T	T						3*	
			40									T	T	T	T							3*
S951N	B-C	10	4	T	T	T	T	T	T	T	T	T	T	T	T	T	T	T	T	T	T	
			6	6	6	6	6	6	6	T	T	T	T	T	T	T	T	T	T	T	T	T
			10			3	3	3	4.5	7.5	8.5	T	T	T	T		3*	3	3	3	4.5	
			16					3	4.5	5	7.5	T	T	T	T			3*	3	4.5		
			20					3	5	6	T	T	T	T	T			3*	3			
			25						5	6	T	T	T	T	T						3*	
			32							6	7.5	T	T	T	T						3*	
			40								7.5	T	T	T	T							3*
S971N	B-C	10	4	T	T	T	T	T	T	T	T	T	T	T	T	T	T	T	T	T	T	
			6	6	6	6	6	6	6	12	T	T	T	T	T	T	T	T	T	T	T	T
			10			3	3	3	4.5	7.5	8.5	T	T	T	T		3*	3	3	3	4.5	
			16					3	4.5	5	7.5	T	T	T	T			3*	3	4.5		
			20					3	5	6	T	T	T	T	T			3*	3			
			25						5	6	T	T	T	T	T						3*	
			32							6	7.5	T	T	T	T						3*	
			40								7.5	T	T	T	T							3*

Supply side circuit-breaker 4P (load side circuit branched between one phase and the neutral)
Load side circuit-breaker 1P+N (230/240 V)

*Value valid only for magnetic only supply side circuit-breaker

**Neutral 50%

T2												T3											
N,S,H,L												N,S											
TMD, MA						EL						TMD,MA											
160												250											
63	80	100	125**	125	160**	160	10	25	63	100	160	63	80	100	125**	125	160**	160	200**	200	250**	250	
T	T	T	T	T	T	T	T	T	T	T	T	T	T	T	T	T	T	T	T	T	T	T	
T	T	T	T	T	T	T		T	T	T	T	T	T	T	T	T	T	T	T	T	T	T	
T	T	T	T	T	T	T		T	T	T	T	T	T	T	T	T	T	T	T	T	T	T	
T	T	T	T	T	T	T		T	T	T	T	T	T	T	T	T	T	T	T	T	T	T	
T	T	T	T	T	T	T		T	T	T	T	T	T	T	T	T	T	T	T	T	T	T	
T	T	T	T	T	T	T		T	T	T	T	T	T	T	T	T	T	T	T	T	T	T	
	T	T	T	T	T	T		T	T	T		T	T	T	T	T	T	T	T	T	T	T	
	T*	T		T	T	T				T	T		T*	T		T	T	T	T	T	T	T	
T	T	T	T	T	T	T	T	T	T	T	T	T	T	T	T	T	T	T	T	T	T	T	
T	T	T	T	T	T	T		T	T	T	T	T	T	T	T	T	T	T	T	T	T	T	
T	T	T	T	T	T	T		T	T	T	T	T	T	T	T	T	T	T	T	T	T	T	
5	T	T	T	T	T	T			T	T	T	5	T	T	T	T	T	T	T	T	T	T	
5	T	T	T	T	T	T			T	T	T	5	T	T	T	T	T	T	T	T	T	T	
5	T	T	T	T	T	T			T	T	T	5	T	T	T	T	T	T	T	T	T	T	
	T	T	T	T	T	T			T	T	T		T	T	T	T	T	T	T	T	T	T	
	T*	T		T	T	T				T	T		T*	T		T	T	T	T	T	T	T	
T	T	T	T	T	T	T	T	T	T	T	T	T	T	T	T	T	T	T	T	T	T	T	
T	T	T	T	T	T	T		T	T	T	T	T	T	T	T	T	T	T	T	T	T	T	
7.5	8.5	T	T	T	T	T		T	T	T	T	7.5	8.5	T	T	T	T	T	T	T	T	T	
5	7.5	T	7.5	T	T	T			T	T	T	5	7.5	T	7.5	T	T	T	T	T	T	T	
5	6	T	6	T	T	T			T	T	T	5	6	T	6	T	T	T	T	T	T	T	
5	6	T	6	T	T	T			T	T	T		5	6	T	6	T	T	T	T	T	T	
	6	7.5	6	T	T	T			T	T	T		6	7.5	6	T	T	T	T	T	T	T	
	6*	7.5		T	T	T				T	T		6*	7.5		T	T	T	T	T	T	T	
T	T	T	T	T	T	T	T	T	T	T	T	T	T	T	T	T	T	T	T	T	T	T	
T	T	T	T	T	T	T		T	T	T	T	T	T	T	T	T	T	T	T	T	T	T	
7.5	8.5	T	T	T	T	T		T	T	T	T	7.5	8.5	T	T	T	T	T	T	T	T	T	
5	7.5	T	7.5	T	T	T			T	T	T	5	7.5	T	7.5	T	T	T	T	T	T	T	
5	6	T	6	T	T	T			T	T	T	5	6	T	6	T	T	T	T	T	T	T	
5	6	T	6	T	T	T			T	T	T	5	6	T	6	T	T	T	T	T	T	T	
	6	7.5	6	T	T	T			T	T	T		6	7.5	6	T	T	T	T	T	T	T	
	6*	7.5		T	T	T				T	T		6*	7.5		T	T	T	T	T	T	T	

MCB - S 200 M @ 400/415 V

		Supply s.		S 290	
		Char.	D		
		Icu [kA]	15		
Load s.			In [A]	80	100
S 200 M	C	15	≤ 2	T	T
			3	T	T
			4	T	T
	B-C	15	6	10.5	T
			8	10.5	T
			10	5	8
			13	4.5	7
			16	4.5	7
			20	3.5	5
			25	3.5	5
			32		4.5
			40		
			50		
			63		
			D	15	≤ 2
	3	T			T
	4	T			T
	6	10.5			T
	8	10.5			T
	10	5			8
	16	3			5
	20	3			5
	25				4
	32				
	40				
	50				
	K	15	≤ 2	T	T
			3	T	T
			4	T	T
			6	10.5	T
			8	10.5	T
			10	5	8
			16	3	5
20			3	5	
25				4	
32					
40					
50					
63					

MCB - S 200 P @400/415 V

		Supply s.		S 290		
		Char.	D			
		Icu [kA]	15			
load s.			In [A]	80	100	
S 200 P	C	25	≤ 2	T	T	
			3	T	T	
			4	T	T	
	B-C	25	6	10.5	T	
			8	10.5	T	
			10	5	8	
			13	4.5	7	
			16	4.5	7	
			20	3.5	5	
			25	3.5	5	
			32		4.5	
			40			
			50			
	63					
	D	25	≤ 2	T	T	
			3	T	T	
			4	T	T	
			6	10.5	T	
			8	10.5	T	
			10	5	8	
			13	3	5	
			16	3	5	
		20	3	5		
		25		4		
		15	32			
			40			
			50			
			63			
	K	25	≤ 2	T	T	
			3	T	T	
			4	T	T	
			6	10.5	T	
			8	10.5	T	
			10	5	8	
			13	3	5	
			16	3	5	
		20	3	5		
		25		4		
		15	32			
40						
50						
63						
Z	25	≤ 2	T	T		
		3	T	T		
		4	T	T		
		6	10.5	T		
		8	10.5	T		
		10	5	8		
		16	4.5	7		
		20	3.5	5		
	25	3.5	5			
	15	32	3	4.5		
		40	3	4.5		
		50		3		
		63				

S 800 S - S 200 @230/400 V

L.	Char.	Icu [kA]	E. S 800 S									
			B									
			In [A]	25	32	40	50	63	80	100	125	
S 200	B	6	6			0.4	0.5	0.7	1	1.5	2.6	
			10				0.4	0.6	0.7	1	1.4	
			13					0.5	0.7	0.9	1.3	
			16						0.7	0.9	1.3	
			20							0.9	1.3	
			25								0.9	1.3
			32								0.8	1.1
			40								0.8	1.1
			50									1
			63									0.9

L.	Char.	Icu [kA]	E. S 800 S													
			C													
			In [A]	25	32	40	50	63	80	100	125					
S 200	B	6	6			0.4	0.5	0.7	0.9	1.4	2.4	4.8				
			10				0.3	0.4	0.5	0.7	0.9	1.3	2			
			13					0.3	0.4	0.5	0.7	0.9	1.3	1.9		
			16						0.3	0.4	0.5	0.7	0.9	1.3	1.9	
			20							0.4	0.5	0.7	0.9	1.2	1.8	
			25								0.4	0.5	0.7	0.9	1.2	1.8
			32									0.5	0.6	0.8	1	1.4
			40										0.6	0.8	1	1.4
			50											0.7	0.9	1.3
			63												0.9	1.2

L.	Char.	Icu [kA]	E. S 800 S											
			B											
			In [A]	25	32	40	50	63	80	100	125			
S 200	C	6	0.5	T	T	T	T	T	T	T	T			
			1	3.3	T	T	T	T	T	T	T			
			1.6	0.6	1.3	T	T	T	T	T	T			
			2	0.4	0.7	1.3	T	T	T	T	T			
			3		0.4	0.6	0.7	1.1	2.6	T	T			
			4			0.4	0.6	0.7	1	1.7	3.1	T		
			6				0.4	0.5	0.7	1	1.5	2.6		
			8					0.4	0.6	0.7	1	1.4		
			10						0.4	0.6	0.7	1	1.4	
			13							0.5	0.7	0.9	1.3	
			16								0.7	0.9	1.3	
			20									0.9	1.3	
			25										0.9	1.3
			32										0.8	1.1
			40										0.8	1.1
50											1			
63											0.9			

L.	Char.	Icu [kA]	E. S 800 S													
			C													
			In [A]	25	32	40	50	63	80	100	125					
S 200	C	6	0.5	T	T	T	T	T	T	T	T					
			1	T	T	T	T	T	T	T	T					
			1.6	0.6	T	T	T	T	T	T	T					
			2	0.5	1	T	T	T	T	T	T					
			3	0.3	0.5	0.7	1.2	2.1	T	T	T					
			4	0.3	0.4	0.7	1	1.5	2.6	T	T					
			6		0.4	0.5	0.7	0.9	1.4	2.4	4.8					
			8			0.3	0.4	0.5	0.7	0.9	1.3	2				
			10				0.3	0.4	0.5	0.7	0.9	1.3	2			
			13					0.3	0.4	0.5	0.7	0.9	1.3	1.9		
			16						0.3	0.4	0.5	0.7	0.9	1.3	1.9	
			20							0.4	0.5	0.7	0.9	1.2	1.8	
			25								0.4	0.5	0.7	0.9	1.2	1.8
			32									0.5	0.6	0.8	1	1.4
			40										0.6	0.8	1	1.4
50											0.7	0.9	1.3			
63												0.9	1.2			

L.	Char.	Icu [kA]	E. S 800 S									
			B									
			In [A]	25	32	40	50	63	80	100	125	
S 200	D	6	0.5	T	T	T	T	T	T	T	T	
			1	0.8	4.5	T	T	T	T	T	T	
			1.6	0.5	1	2.3	T	T	T	T	T	
			2	0.3	0.5	0.7	2.3	T	T	T	T	
			3		0.4	0.5	0.7	1.2	2.5	T	T	
			4			0.4	0.4	0.7	1	1.7	3	T
			6					0.6	0.8	1.2	2	3.6
			8						0.7	0.9	1.3	2
			10							0.9	1.3	2
			13								1	1.5
			16									1.5
			20									
			25									
			32									
			40									
50												
63												

L.	Char.	Icu [kA]	E. S 800 S								
			C								
			In [A]	25	32	40	50	63	80	100	125
S 200	D	6	0.5	T	T	T	T	T	T	T	T
			1	2.1	T	T	T	T	T	T	T
			1.6	0.8	2.3	T	T	T	T	T	T
			2	0.4	0.7	2.3	T	T	T	T	T
			3	0.3	0.5	0.7	1.2	2.2	T	T	T
			4	0.3	0.4	0.7	1	1.4	2.6	T	T
			6		0.4	0.6	0.8	1.1	1.8	3.2	T
			8			0.5	0.7	0.9	1.2	1.8	2.8
			10				0.7	0.9	1.2	1.8	2.8
			13					0.7	1	1.4	2
			16						1	1.4	2
			20							1	1.4
			25								1.4
			32								
			40								
50											
63											

L.	Char.	Icu [kA]	E. S 800 S									
			B									
			In [A]	25	32	40	50	63	80	100	125	
S 200	K	6	0.5	T	T	T	T	T	T	T	T	
			1	0.8	5	T	T	T	T	T	T	
			1.6	0.5	1	2.1	T	T	T	T	T	
			2	0.3	0.5	0.7	2.1	T	T	T	T	
			3		0.4	0.5	0.7	1.2	2.5	T	T	
			4			0.4	0.4	0.7	1	1.7	3	T
			6					0.6	0.8	1.2	2	3.6
			8						0.7	0.9	1.3	2
			10							0.9	1.3	2
			13								1	1.5
			16									1.5
			20									
			25									
			32									
			40									
50												
63												

L.	Char.	Icu [kA]	E. S 800 S								
			C								
			In [A]	25	32	40	50	63	80	100	125
S 200	K	6	0.5	T	T	T	T	T	T	T	T
			1	2.1	T	T	T	T	T	T	T
			1.6	0.8	2.3	T	T	T	T	T	T
			2	0.4	0.7	2.3	T	T	T	T	T
			3	0.3	0.5	0.7	1.2	2.2	T	T	T
			4	0.3	0.4	0.7	1	1.4	2.6	T	T
			6		0.4	0.6	0.8	1.1	1.8	3.2	T
			8			0.5	0.7	0.9	1.2	1.8	2.8
			10				0.7	0.9	1.2	1.8	2.8
			13					0.7	1	1.4	2
			16						1	1.4	2
			20							1	1.4
			25								1.4
			32								
			40								
50											
63											

E. = supply side L. = load side
T = total selectivity up to breaking capacity of load side breaker
Selectivity limits are specified in kA

System pro M compact®

Technical details

Coordination tables: selectivity

L.	Char.	Icu [kA]	E. S 800 S																			
			D																			
			In [A]	25	32	40	50	63	80	100	125											
S 200	B	6	6	0.5	1	1.2	2	2.8	T	T	T											
			10	0.4	0.6	0.8	1.1	1.4	2.8	3.9	T											
			13	0.4	0.6	0.8	1.1	1.4	2.5	3.3	T											
			16		0.6	0.8	1.1	1.4	2.5	3.3	5.6											
			20			0.8	1.1	1.3	2.3	3	4.7											
			25			0.8	1.1	1.3	2.3	3	4.7											
			32				0.9	1.1	1.9	2.4	3.7											
			40					1.1	1.9	2.4	3.7											
			50						1.5	1.9	2.3											
			63								1.7	2.3										

L.	Char.	Icu [kA]	E. S 800 S																			
			D																			
			In [A]	25	32	40	50	63	80	100	125											
S 200	C	6	0.5	T	T	T	T	T	T	T	T	T	T	T	T	T	T	T	T	T	T	
			1	T	T	T	T	T	T	T	T	T	T	T	T	T	T	T	T	T	T	T
			1.6	T	T	T	T	T	T	T	T	T	T	T	T	T	T	T	T	T	T	T
			2	T	T	T	T	T	T	T	T	T	T	T	T	T	T	T	T	T	T	T
			3	0.7	2.2	4.4	T	T	T	T	T	T										
			4	0.7	1.3	2.2	4.4	T	T	T	T	T										
			6	0.5	1	1.2	2	2.8	T	T	T	T										
			8	0.4	0.6	0.8	1.1	1.4	2.8	3.9	T											
			10	0.4	0.6	0.8	1.1	1.4	2.8	3.9	T											
			13	0.4	0.6	0.8	1.1	1.4	2.5	3.3	5.6											
			16		0.6	0.8	1.1	1.4	2.5	3.3	5.6											
			20			0.8	1.1	1.3	2.3	3	4.7											
			25			0.8	1.1	1.3	2.3	3	4.7											
			32				0.9	1.1	1.9	2.4	3.7											
			40					1.1	1.9	2.4	3.7											
			50						1.5	1.9	2.3											
			63								1.7	2.3										

L.	Char.	Icu [kA]	E. S 800 S																			
			D																			
			In [A]	25	32	40	50	63	80	100	125											
S 200	D	6	0.5	T	T	T	T	T	T	T	T	T	T	T	T	T	T	T	T	T	T	
			1	T	T	T	T	T	T	T	T	T	T	T	T	T	T	T	T	T	T	T
			1.6	T	T	T	T	T	T	T	T	T	T	T	T	T	T	T	T	T	T	T
			2	2.3	T	T	T	T	T	T	T	T	T	T	T	T	T	T	T	T	T	T
			3	0.7	1.3	4.4	T	T	T	T	T	T										
			4	0.7	1	2.2	4.4	T	T	T	T	T										
			6	0.6	0.8	1.5	2.5	3.6	T	T	T	T										
			8	0.5	0.7	1.1	1.5	2	4	5.5	T											
			10	0.5	0.7	1.1	1.5	2	4	5.5	T											
			13		0.6	0.9	1.2	1.5	2.6	3.4	5.2											
			16			0.9	1.2	1.5	2.6	3.4	5.2											
			20				0.9	1.1	1.8	2.2	3.2											
			25					1.1	1.8	2.2	3.2											
			32						1.7	2	2.9											
			40							1.9	2.6											
			50								2.2											
			63																			

L.	Char.	Icu [kA]	E. S 800 S																			
			D																			
			In [A]	25	32	40	50	63	80	100	125											
S 200	K	6	0.5	T	T	T	T	T	T	T	T	T	T	T	T	T	T	T	T	T	T	
			1	T	T	T	T	T	T	T	T	T	T	T	T	T	T	T	T	T	T	T
			1.6	T	T	T	T	T	T	T	T	T	T	T	T	T	T	T	T	T	T	T
			2	2.3	T	T	T	T	T	T	T	T	T	T	T	T	T	T	T	T	T	T
			3	0.7	1.3	4.4	T	T	T	T	T	T										
			4	0.7	1	2.2	4.4	T	T	T	T	T										
			6	0.6	0.8	1.5	2.5	3.6	T	T	T	T										
			8	0.5	0.7	1.1	1.5	2	4	5.5	T											
			10	0.5	0.7	1.1	1.5	2	4	5.5	T											
			13		0.6	0.9	1.2	1.5	2.6	3.4	5.2											
			16			0.9	1.2	1.5	2.6	3.4	5.2											
			20				0.9	1.1	1.8	2.2	3.2											
			25					1.1	1.8	2.2	3.2											
			32						1.7	2	2.9											
			40							1.9	2.6											
			50								2.2											
			63																			

E. = supply side L. = load side
 T = total selectivity up to breaking capacity of load side breaker
 Selectivity limits are specified in kA

System pro M compact®

Technical details

Coordination tables: selectivity

MCBs

S800 N - S 200 @230/400 V

L.	Char.	E. S800 N												
		Icu [kA]	B											
			In [A]	25	32	40	50	63	80	100	125			
S 200	B	6	6				0.4	0.5	0.7	1	1.5	2.6		
			10				0.4	0.6	0.7	1	1.4			
			13					0.5	0.7	0.9	1.3			
			16						0.7	0.9	1.3			
			20							0.9	1.3			
			25								0.9	1.3		
			32									0.8	1.1	
			40										0.8	1.1
			50											1
			63											

L.	Char.	E. S800 N															
		Icu [kA]	C														
			In [A]	25	32	40	36	63	80	100	125						
S 200	B	6	6					0.4	0.5	0.7	0.9	1.4	2.4	4.8			
			10					0.3	0.4	0.5	0.7	0.9	1.3	2			
			13						0.3	0.4	0.5	0.7	0.9	1.3	1.9		
			16							0.3	0.4	0.5	0.7	0.9	1.3	1.9	
			20								0.4	0.5	0.7	0.9	1.2	1.8	
			25									0.4	0.5	0.7	0.9	1.2	1.8
			32										0.5	0.6	0.8	1	1.4
			40											0.6	0.8	1	1.4
			50												0.7	0.9	1.3
			63													0.9	1.2

L.	Char.	E. S800 N													
		Icu [kA]	B												
			In [A]	25	32	40	50	63	80	100	125				
S 200	C	6	0.5	T	T	T	T	T	T	T	T	T	T	T	
			1	3.3	T	T	T	T	T	T	T	T	T	T	
			1.6	0.6	1.3	T	T	T	T	T	T	T	T	T	
			2	0.4	0.7	1.2	T	T	T	T	T	T	T	T	
			3		0.4	0.6	0.7	1.1	2.6	T	T	T	T	T	
			4		0.4	0.6	0.7	1	1.7	3.1	T	T	T	T	
			6			0.4	0.5	0.7	1	1.5	2.6	T	T	T	
			8				0.4	0.6	0.7	1	1.4	T	T	T	
			10					0.4	0.6	0.7	1	1.4	T	T	
			13						0.5	0.7	0.9	1.3	T	T	
			16							0.7	0.9	1.3	T	T	
			20								0.9	1.3	T	T	
			25									0.9	1.3	T	
			32										0.8	1.1	
			40											0.8	1.1
			50												1
63													0.9		

L.	Char.	E. S800 N															
		Icu [kA]	C														
			In [A]	25	32	40	36	63	80	100	125						
S 200	C	6	0.5	T	T	T	T	T	T	T	T	T	T	T			
			1		T	T	T	T	T	T	T	T	T	T			
			1.6	0.6	T	T	T	T	T	T	T	T	T	T			
			2	0.5	1	T	T	T	T	T	T	T	T	T			
			3		0.3	0.5	0.7	1.2	2.1	T	T	T	T				
			4		0.3	0.4	0.7	1	1.5	2.6	T	T	T				
			6			0.4	0.5	0.7	0.9	1.4	2.4	4.8	T				
			8				0.3	0.4	0.5	0.7	0.9	1.3	2				
			10					0.3	0.4	0.5	0.7	0.9	1.3	2			
			13						0.3	0.4	0.5	0.7	0.9	1.3	1.9		
			16							0.3	0.4	0.5	0.7	0.9	1.3	1.9	
			20								0.4	0.5	0.7	0.9	1.2	1.8	
			25									0.4	0.5	0.7	0.9	1.2	1.8
			32										0.5	0.6	0.8	1	1.4
			40											0.6	0.8	1	1.4
			50												0.7	0.9	1.3
63													0.9	1.2			

L.	Char.	E. S800 N											
		Icu [kA]	B										
			In [A]	25	32	40	50	63	80	100	125		
S 200	D	6	0.5	T	T	T	T	T	T	T	T	T	T
			1	0.8	5	T	T	T	T	T	T	T	T
			1.6	0.5	1	2.3	T	T	T	T	T	T	
			2	0.3	0.5	0.7	2.3	T	T	T	T	T	
			3		0.4	0.5	0.7	1.2	2.5	T	T	T	
			4			0.4	0.4	0.7	1	1.7	3	T	
			6					0.6	0.8	1.2	2	3.6	
			8							0.7	0.9	1.3	2
			10								0.9	1.3	2
			13									1	1.5
			16										1.5
			20										
			25										
			32										
			40										
			50										
50													

L.	Char.	E. S800 N											
		Icu [kA]	C										
			In [A]	25	32	40	36	63	80	100	125		
S 200	D	6	0.5	T	T	T	T	T	T	T	T	T	T
			1	2.1	T	T	T	T	T	T	T	T	
			1.6	0.8	2.3	T	T	T	T	T	T		
			2	0.4	0.7	2.3	T	T	T	T	T		
			3		0.3	0.5	0.7	1.2	2.2	T	T		
			4		0.3	0.4	0.7	1	1.4	2.6	T		
			6			0.4	0.6	0.8	1.1	1.8	3.2		
			8					0.5	0.7	0.9	1.2	1.8	2.8
			10						0.7	0.9	1.2	1.8	2.8
			13							0.7	1	1.4	2
			16								1	1.4	2
			20									1	1.4
			25										1.4
			32										
			40										
			50										
50													

L.	Char.	E. S800 N											
		Icu [kA]	B										
			In [A]	25	32	40	50	63	80	100	125		
S 200	K	6	0.5	T	T	T	T	T	T	T	T	T	
			1	0.8	5	T	T	T	T	T	T		
			1.6	0.5	1	2.3	T	T	T	T	T		
			2	0.3	0.5	0.7	2.3	T	T	T	T		
			3		0.4	0.5	0.7	1.2	2.5	T	T		
			4			0.4	0.4	0.7	1	1.7	3	T	
			6					0.6	0.8	1.2	2	3.6	
			8							0.7	0.9	1.3	2
			10								0.9	1.3	2
			13									1	1.5
			16										1.5
			20										
			25										
			32										
			40										
			50										
50													

L.	Char.	E. S800 N											
		Icu [kA]	C										
			In [A]	25	32	40	50	63	80	100	125		
S 200	K	6	0.5	T	T	T	T	T	T	T	T	T	
			1	2.1	T	T	T	T	T	T	T		
			1.6	0.8	2.3	T	T	T	T	T	T		
			2	0.4	0.7	2.3	T	T	T	T	T		
			3		0.3	0.5	0.7	1.2	2.2	T	T		
			4		0.3	0.4	0.7	1	1.4	2.6	T		
			6			0.4	0.6	0.8	1.1	1.8	3.2		
			8					0.5	0.7	0.9	1.2	1.8	2.8
			10						0.7	0.9	1.2	1.8	2.8
			13							0.7	1	1.4	2
			16								1	1.4	2
			20									1	1.4
			25										1.4
			32										
			40										
			50										
50													

E. = supply side L. = load side
 T = total selectivity up to breaking capacity of load side breaker
 Selectivity limits are specified in kA

11

System pro M compact®

Technical details

Coordination tables: selectivity

L.	Char.	Icu [kA]	E. S800 N									
			D									
			In [A]	25	32	40	36	63	80	100	125	
S 200	B	6	6	0.5	1	1.2	2	2.8	T	T	T	
			10	0.4	0.6	0.8	1.1	1.4	2.8	3.9	T	
			13	0.4	0.6	0.8	1.1	1.4	2.5	3.3	5.6	
			16		0.6	0.8	1.1	1.4	2.5	3.3	5.6	
			20			0.8	1.1	1.3	2.3	3	4.7	
			25			0.8	1.1	1.3	2.3	3	4.7	
			32				0.9	1.1	1.9	2.4	3.7	
			40					1.1	1.9	2.4	3.7	
			50						1.5	1.9	2.3	
			63							1.7	2.3	

L.	Char.	Icu [kA]	E. S800 N									
			D									
			In [A]	25	32	40	36	63	80	100	125	
S 200	C	6	0.5	T	T	T	T	T	T	T	T	T
			1	T	T	T	T	T	T	T	T	T
			1.6	T	T	T	T	T	T	T	T	T
			2	T	T	T	T	T	T	T	T	T
			3	0.7	2.2	4.4	T	T	T	T	T	
			4	0.7	1.3	2.2	4.4	T	T	T	T	
			6	0.5	1	1.2	2	2.8	T	T	T	
			8	0.4	0.6	0.8	1.1	1.4	2.8	3.9	T	
			10	0.4	0.6	0.8	1.1	1.4	2.8	3.9	T	
			13	0.4	0.6	0.8	1.1	1.4	2.5	3.3	5.6	
			16		0.6	0.8	1.1	1.4	2.5	3.3	5.6	
			20			0.8	1.1	1.3	2.3	3	4.7	
			25			0.8	1.1	1.3	2.3	3	4.7	
			32				0.9	1.1	1.9	2.4	3.7	
			40					1.1	1.9	2.4	3.7	
			50						1.5	1.9	2.3	
			63							1.7	2.3	

L.	Char.	Icu [kA]	E. S800 N									
			D									
			In [A]	25	32	40	36	63	80	100	125	
S 200	D	6	0.5	T	T	T	T	T	T	T	T	T
			1	T	T	T	T	T	T	T	T	T
			1.6	T	T	T	T	T	T	T	T	T
			2	2.3	T	T	T	T	T	T	T	T
			3	0.7	1.3	4.4	T	T	T	T	T	
			4	0.7	1	2.2	4.4	T	T	T	T	
			6	0.6	0.8	1.5	2.5	3.6	T	T	T	
			8	0.5	0.7	1.1	1.5	2	4	5.5	T	
			10	0.5	0.7	1.1	1.5	2	4	5.5	T	
			13		0.6	0.9	1.2	1.5	2.6	3.4	5.2	
			16			0.9	1.2	1.5	2.6	3.4	5.2	
			20				0.9	1.1	1.8	2.2	3.2	
			25					1.1	1.8	2.2	3.2	
			32						1.7	2	2.9	
			40							1.9	2.6	
			50								2.2	
			63									

L.	Char.	Icu [kA]	E. S800 N									
			D									
			In [A]	25	32	40	50	63	80	100	125	
S 200	K	6	0.5	T	T	T	T	T	T	T	T	T
			1	T	T	T	T	T	T	T	T	T
			1.6	T	T	T	T	T	T	T	T	T
			2	2.3	T	T	T	T	T	T	T	T
			3	0.7	1.3	4.4	T	T	T	T	T	
			4	0.7	1	2.2	4.4	T	T	T	T	
			6	0.6	0.8	1.5	2.5	3.6	T	T	T	
			8	0.5	0.7	1.1	1.5	2	4	5.5	T	
			10	0.5	0.7	1.1	1.5	2	4	5.5	T	
			13		0.6	0.9	1.2	1.5	2.6	3.4	5.2	
			16			0.9	1.2	1.5	2.6	3.4	5.2	
			20				0.9	1.1	1.8	2.2	3.2	
			25					1.1	1.8	2.2	3.2	
			32						1.7	2	2.9	
			40							1.9	2.6	
			50								2.2	
			63									

E. = supply side L. = load side
 T = total selectivity up to breaking capacity of load side breaker
 Selectivity limits are specified in kA

System pro M compact®

Technical details Coordination tables: selectivity

MCBs

S800 S - S 200 M @230/400 V

L.	Char.	Icu [kA]	E. S800 S																			
			B																			
			In [A]	25	32	40	50	63	80	100	125											
S 200 M	B	10	6			0.4	0.5	0.7	1	1.5	2.6											
			10				0.4	0.6	0.7	1	1.4											
			13					0.5	0.7	0.9	1.3											
			16						0.7	0.9	1.3											
			20							0.9	1.3											
			25								0.9	1.3										
			32									0.8	1.1									
			40										0.8	1.1								
			50											1								
			63												0.9							

L.	Char.	Icu [kA]	E. S800 S																			
			C																			
			In [A]	25	32	40	50	63	80	100	125											
S 200 M	B	10	6			0.4	0.5	0.7	0.9	1.4	2.4	4.8										
			10			0.3	0.4	0.5	0.7	0.9	1.3	2										
			13				0.3	0.4	0.5	0.7	0.9	1.3	1.9									
			16				0.3	0.4	0.5	0.7	0.9	1.3	1.9									
			20					0.4	0.5	0.7	0.9	1.2	1.8									
			25						0.4	0.5	0.7	0.9	1.2	1.8								
			32							0.5	0.6	0.8	1	1.4								
			40								0.6	0.8	1	1.4								
			50									0.7	0.9	1.3								
			63										0.9	1.2								

L.	Char.	Icu [kA]	E. S800 S																			
			B																			
			In [A]	25	32	40	50	63	80	100	125											
S 200 M	C	10	0.5	T	T	T	T	T	T	T	T	T	T	T	T	T	T	T	T	T	T	
			1	3.3	T	T	T	T	T	T	T	T	T	T	T	T	T	T	T	T	T	T
			1.6	0.6	1.3	T	T	T	T	T	T	T	T	T	T	T	T	T	T	T	T	T
			2	0.4	0.7	1.3	T	T	T	T	T	T	T	T	T	T	T	T	T	T	T	T
			3		0.4	0.6	0.7	1.1	2.6	8.8	T	T	T	T	T	T	T	T	T	T	T	T
			4		0.4	0.6	0.7	1	1.7	3.1	7	T	T	T	T	T	T	T	T	T	T	T
			6			0.4	0.5	0.7	1	1.5	2.6	T	T	T	T	T	T	T	T	T	T	T
			8				0.4	0.6	0.7	1	1.4	T	T	T	T	T	T	T	T	T	T	T
			10				0.4	0.6	0.7	1	1.4	T	T	T	T	T	T	T	T	T	T	T
			13					0.5	0.7	0.9	1.3	T	T	T	T	T	T	T	T	T	T	T
			16						0.7	0.9	1.3	T	T	T	T	T	T	T	T	T	T	T
			20							0.9	1.3	T	T	T	T	T	T	T	T	T	T	T
			25								0.9	1.3	T	T	T	T	T	T	T	T	T	T
			32									0.8	1.1	T	T	T	T	T	T	T	T	T
			40										0.8	1.1	T	T	T	T	T	T	T	T
			50											1	T	T	T	T	T	T	T	T
			63												0.9	T	T	T	T	T	T	T

L.	Char.	Icu [kA]	E. S800 S																			
			C																			
			In [A]	25	32	40	50	63	80	100	125											
S 200 M	C	10	0.5	T	T	T	T	T	T	T	T	T	T	T	T	T	T	T	T	T	T	
			1		T	T	T	T	T	T	T	T	T	T	T	T	T	T	T	T	T	T
			1.6	0.6	T	T	T	T	T	T	T	T	T	T	T	T	T	T	T	T	T	T
			2	0.5	1	T	T	T	T	T	T	T	T	T	T	T	T	T	T	T	T	T
			3		0.3	0.5	0.7	1.2	2.1	6.4	T	T	T	T	T	T	T	T	T	T	T	T
			4		0.3	0.4	0.7	1	1.5	2.6	6.1	T	T	T	T	T	T	T	T	T	T	T
			6			0.4	0.5	0.7	0.9	1.4	2.4	4.8	T	T	T	T	T	T	T	T	T	T
			8			0.3	0.4	0.5	0.7	0.9	1.3	2	T	T	T	T	T	T	T	T	T	T
			10			0.3	0.4	0.5	0.7	0.9	1.3	2	T	T	T	T	T	T	T	T	T	T
			13			0.3	0.4	0.5	0.7	0.9	1.3	1.9	T	T	T	T	T	T	T	T	T	T
			16			0.3	0.4	0.5	0.7	0.9	1.3	1.9	T	T	T	T	T	T	T	T	T	T
			20				0.4	0.5	0.7	0.9	1.2	1.8	T	T	T	T	T	T	T	T	T	T
			25					0.4	0.5	0.7	0.9	1.2	1.8	T	T	T	T	T	T	T	T	T
			32						0.5	0.6	0.8	1	1.4	T	T	T	T	T	T	T	T	T
			40							0.6	0.8	1	1.4	T	T	T	T	T	T	T	T	T
			50								0.7	0.9	1.3	T	T	T	T	T	T	T	T	T
			63									0.9	1.2	T	T	T	T	T	T	T	T	T

L.	Char.	Icu [kA]	E. S800 S																			
			B																			
			In [A]	25	32	40	50	63	80	100	125											
S 200 M	D	10	0.5	T	T	T	T	T	T	T	T	T	T	T	T	T	T	T	T	T	T	
			1	0.8	5	T	T	T	T	T	T	T	T	T	T	T	T	T	T	T	T	T
			1.6	0.5	1	2.3	T	T	T	T	T	T	T	T	T	T	T	T	T	T	T	T
			2	0.3	0.5	0.7	2.3	T	T	T	T	T	T	T	T	T	T	T	T	T	T	T
			3		0.4	0.5	0.7	1.2	2.5	8.6	T	T	T	T	T	T	T	T	T	T	T	T
			4		0.4	0.4	0.7	1	1.7	3	7.7	T	T	T	T	T	T	T	T	T	T	T
			6				0.6	0.8	1.2	2	3.6	T	T	T	T	T	T	T	T	T	T	T
			8					0.7	0.9	1.3	2	T	T	T	T	T	T	T	T	T	T	T
			10						0.9	1.3	2	T	T	T	T	T	T	T	T	T	T	T
			13							1	1.5	T	T	T	T	T	T	T	T	T	T	T
			16								1.5	T	T	T	T	T	T	T	T	T	T	T
			20									T	T	T	T	T	T	T	T	T	T	T
			25										T	T	T	T	T	T	T	T	T	T
			32											T	T	T	T	T	T	T	T	T
			40												T	T	T	T	T	T	T	T
			50													T	T	T	T	T	T	T
			63														T	T	T	T	T	T

L.	Char.	Icu [kA]	E. S800 S																			
			C																			
			In [A]	25	32	40	50	63	80	100	125											
S 200 M	D	10	0.5	T	T	T	T	T	T	T	T	T	T	T	T	T	T	T	T	T	T	
			1	2.1	T	T	T	T	T	T	T	T	T	T	T	T	T	T	T	T	T	T
			1.6	0.8	2.3	T	T	T	T	T	T	T	T	T	T	T	T	T	T	T	T	T
			2	0.4	0.7	2.3	T	T	T	T	T	T	T	T	T	T	T	T	T	T	T	T
			3		0.3	0.5	0.7	1.2	2.2	6.4	T	T	T	T	T	T	T	T	T	T	T	T
			4		0.3	0.4	0.7	1	1.4	2.6	6.2	T	T	T	T	T	T	T	T	T	T	T
			6			0.4	0.6	0.8	1.1	1.8	3.2	6.4	T	T	T	T	T	T	T	T	T	T
			8				0.5	0.7	0.9	1.2	1.8	2.8	T	T	T	T	T	T	T	T	T	T
			10					0.7	0.9	1.2	1.8	2.8	T	T	T	T	T	T	T	T	T	T
			13						0.7	1	1.4	2	T	T	T	T	T	T	T	T	T	T
			16							1												

System pro M compact®

Technical details

Coordination tables: selectivity

L.	Char.	Icu [kA]	E. S800 S									
			D									
			In [A]	25	32	40	50	63	80	100	125	
S 200 M	B	10	6	0.5	1	1.2	2	2.8	T	T	T	
			10	0.4	0.6	0.8	1.1	1.4	2.8	3.9	7.4	
			13	0.4	0.6	0.8	1.1	1.4	2.5	3.3	5.6	
			16		0.6	0.8	1.1	1.4	2.5	3.3	5.6	
			20			0.8	1.1	1.3	2.3	3	4.7	
			25			0.8	1.1	1.3	2.3	3	4.7	
			32				0.9	1.1	1.9	2.4	3.7	
			40					1.1	1.9	2.4	3.7	
			50						1.5	1.9	2.3	
			63							1.7	2.3	

L.	Char.	Icu [kA]	E. S800 S									
			D									
			In [A]	25	32	40	50	63	80	100	125	
S 200 M	C	10	0.5	T	T	T	T	T	T	T	T	T
			1	T	T	T	T	T	T	T	T	T
			1.6	T	T	T	T	T	T	T	T	T
			2	T	T	T	T	T	T	T	T	T
			3	0.7	2.2	4.4	T	T	T	T	T	
			4	0.7	1.3	2.2	4.4	7.7	T	T	T	
			6	0.5	1	1.2	2	2.8	9.9	T	T	
			8	0.4	0.6	0.8	1.1	1.4	2.8	3.9	7.4	
			10	0.4	0.6	0.8	1.1	1.4	2.8	3.9	7.4	
			13	0.4	0.6	0.8	1.1	1.4	2.5	3.3	5.6	
			16		0.6	0.8	1.1	1.4	2.5	3.3	5.6	
			20			0.8	1.1	1.3	2.3	3	4.7	
			25			0.8	1.1	1.3	2.3	3	4.7	
			32				0.9	1.1	1.9	2.4	3.7	
			40					1.1	1.9	2.4	3.7	
			50						1.5	1.9	2.3	
			63							1.7	2.3	

L.	Char.	Icu [kA]	E. S800 S									
			D									
			In [A]	25	32	40	50	63	80	100	125	
S 200 M	D	10	0.5	T	T	T	T	T	T	T	T	T
			1	T	T	T	T	T	T	T	T	T
			1.6	T	T	T	T	T	T	T	T	T
			2	2.3	T	T	T	T	T	T	T	T
			3	0.7	1.3	4.4	T	T	T	T	T	
			4	0.7	1	2.2	4.4	7.7	T	T	T	
			6	0.6	0.8	1.5	2.5	3.6	T	T	T	
			8	0.5	0.7	1.1	1.5	2	4	5.5	T	
			10	0.5	0.7	1.1	1.5	2	4	5.5	T	
			13		0.6	0.9	1.2	1.5	2.6	3.4	5.2	
			16			0.9	1.2	1.5	2.6	3.4	5.2	
			20				0.9	1.1	1.8	2.2	3.2	
			25					1.1	1.8	2.2	3.2	
			32						1.7	2	2.9	
			40							1.9	2.6	
			50								2.2	
			63									

L.	Char.	Icu [kA]	E. S800 S									
			D									
			In [A]	25	32	40	50	63	80	100	125	
S 200 M	K	10	0.5	T	T	T	T	T	T	T	T	T
			1	T	T	T	T	T	T	T	T	T
			1.6	T	T	T	T	T	T	T	T	T
			2	2.3	T	T	T	T	T	T	T	T
			3	0.7	1.3	4.4	T	T	T	T	T	
			4	0.7	1	2.2	4.4	7.7	T	T	T	
			6	0.6	0.8	1.5	2.5	3.6	T	T	T	
			8	0.5	0.7	1.1	1.5	2	4	5.5	T	
			10	0.5	0.7	1.1	1.5	2	4	5.5	T	
			13		0.6	0.9	1.2	1.5	2.6	3.4	5.2	
			16			0.9	1.2	1.5	2.6	3.4	5.2	
			20				0.9	1.1	1.8	2.2	3.2	
			25					1.1	1.8	2.2	3.2	
			32						1.7	2	2.9	
			40							1.9	2.6	
			50								2.2	
			63									

E. = supply side L. = load side
 T = total selectivity up to breaking capacity of load side breaker
 Selectivity limits are specified in kA

System pro M compact®

Technical details

Coordination tables: selectivity

L.	Char.	Icu [kA]	E. S800 N									
			D									
			In [A]	25	32	40	36	63	80	100	125	
S 200 M	B	10	6	0.5	1	1.2	2	2.8	T	T	T	
			10	0.4	0.6	0.8	1.1	1.4	2.8	3.9	7.4	
			13	0.4	0.6	0.8	1.1	1.4	2.5	3.3	5.6	
			16		0.6	0.8	1.1	1.4	2.5	3.3	5.6	
			20			0.8	1.1	1.3	2.3	3	4.7	
			25			0.8	1.1	1.3	2.3	3	4.7	
			32				0.9	1.1	1.9	2.4	3.7	
			40					1.1	1.9	2.4	3.7	
			50						1.5	1.9	2.3	
			63							1.7	2.3	

L.	Char.	Icu [kA]	E. S800 N									
			D									
			In [A]	25	32	40	36	63	80	100	125	
S 200 M	C	10	0.5	T	T	T	T	T	T	T	T	
			1	T	T	T	T	T	T	T	T	
			1.6	T	T	T	T	T	T	T	T	
			2	T	T	T	T	T	T	T	T	
			3	0.7	2.2	4.4	T	T	T	T	T	
			4	0.7	1.3	2.2	4.4	7.7	T	T	T	
			6	0.5	1	1.2	2	2.8	T	T	T	
			8	0.4	0.6	0.8	1.1	1.4	2.8	3.9	7.4	
			10	0.4	0.6	0.8	1.1	1.4	2.8	3.9	7.4	
			13	0.4	0.6	0.8	1.1	1.4	2.5	3.3	5.6	
			16		0.6	0.8	1.1	1.4	2.5	3.3	5.6	
			20			0.8	1.1	1.3	2.3	3	4.7	
			25			0.8	1.1	1.3	2.3	3	4.7	
			32				0.9	1.1	1.9	2.4	3.7	
			40					1.1	1.9	2.4	3.7	
			50						1.5	1.9	2.3	
			63							1.7	2.3	

L.	Char.	Icu [kA]	E. S800 N									
			D									
			In [A]	25	32	40	36	63	80	100	125	
S 200 M	D	10	0.5	T	T	T	T	T	T	T	T	
			1	T	T	T	T	T	T	T	T	
			1.6	T	T	T	T	T	T	T	T	
			2	2.3	T	T	T	T	T	T	T	
			3	0.7	1.3	4.4	T	T	T	T	T	
			4	0.7	1	2.2	4.4	7.7	T	T	T	
			6	0.6	0.8	1.5	2.5	3.6	T	T	T	
			8	0.5	0.7	1.1	1.5	2	4	5.5	T	
			10	0.5	0.7	1.1	1.5	2	4	5.5	T	
			13		0.6	0.9	1.2	1.5	2.6	3.4	5.2	
			16			0.9	1.2	1.5	2.6	3.4	5.2	
			20				0.9	1.1	1.8	2.2	3.2	
			25					1.1	1.8	2.2	3.2	
			32						1.7	2	2.9	
			40							1.9	2.6	
			50								2.2	
			63									2.2

L.	Char.	Icu [kA]	E. S800 N									
			D									
			In [A]	25	32	40	50	63	80	100	125	
S 200 M	K	10	0.5	T	T	T	T	T	T	T	T	
			1	T	T	T	T	T	T	T	T	
			1.6	T	T	T	T	T	T	T	T	
			2	2.3	T	T	T	T	T	T	T	
			3	0.7	1.3	4.4	T	T	T	T	T	
			4	0.7	1	2.2	4.4	7.7	T	T	T	
			6	0.6	0.8	1.5	2.5	3.6	T	T	T	
			8	0.5	0.7	1.1	1.5	2	4	5.5	T	
			10	0.5	0.7	1.1	1.5	2	4	5.5	T	
			13		0.6	0.9	1.2	1.5	2.6	3.4	5.2	
			16			0.9	1.2	1.5	2.6	3.4	5.2	
			20				0.9	1.1	1.8	2.2	3.2	
			25					1.1	1.8	2.2	3.2	
			32						1.7	2	2.9	
			40							1.9	2.6	
			50								2.2	
			63									2.2

E. = supply side L. = load side
 T = total selectivity up to breaking capacity of load side breaker
 Selectivity limits are specified in kA

S800 S - S 200 P @230/400 V

L.	Char.	E.		S800 S											
		Icu [kA]	B												
			In [A]	25	32	40	50	63	80	100	125				
S 200 P	B	25	6			0.4	0.5	0.7	1	1.5	2.6				
			10			0.4	0.6	0.7	1	1.4					
			13				0.5	0.7	0.9	1.3					
			16					0.7	0.9	1.3					
			20						0.9	1.3					
			25							0.9	1.3				
			32								0.8	1.1			
		15	40								0.8	1.1			
			50									1			
			63										0.9		

L.	Char.	E.		S800 S										
		Icu [kA]	C											
			In [A]	25	32	40	50	63	80	100	125			
S 200 P	B	25	6				0.4	0.5	0.7	1	1.5	2.6		
			10				0.4	0.6	0.7	1	1.4			
			13					0.5	0.7	0.9	1.3			
			16						0.7	0.9	1.3			
			20							0.9	1.3			
			25								0.9	1.3		
			32									0.8	1.1	
		15	40									0.8	1.1	
			50										1	
			63											0.9

L.	Char.	E.		S800 S										
		Icu [kA]	B											
			In [A]	25	32	40	50	63	80	100	125			
S 200 P	C	25	0.5	T	T	T	T	T	T	T	T	T	T	T
			1	3.3	T	T	T	T	T	T	T	T	T	
			1.6	0.6	1.3	T	T	T	T	T	T	T	T	
			2	0.4	0.7	1.2	T	T	T	T	T	T	T	
			3		0.6	0.7	1.1	2.6	8.8	T				
			4		0.6	0.7	1	1.7	3.1	7				
			6		0.4	0.5	0.7	1	1.5	2.6				
		15	8			0.4	0.6	0.7	1	1.4				
			10			0.4	0.6	0.7	1	1.4				
			13				0.5	0.7	0.9	1.3				
			16					0.7	0.9	1.3				
			20						0.9	1.3				
			25							0.9	1.3			
			32								0.8	1.1		

L.	Char.	E.		S800 S									
		Icu [kA]	C										
			In [A]	25	32	40	50	63	80	100	125		
S 200 P	C	25	0.5	T	T	T	T	T	T	T	T	T	T
			1	3.3	T	T	T	T	T	T	T	T	
			1.6	0.6	1.3	T	T	T	T	T	T		
			2	0.4	0.7	1.3	T	T	T	T	T		
			3		0.4	0.6	0.7	1.1	2.6	8.8	T		
			4		0.4	0.6	0.7	1	1.7	3.1	7		
			6			0.4	0.5	0.7	1	1.5	2.6		
		15	8				0.4	0.6	0.7	1	1.4		
			10				0.4	0.6	0.7	1	1.4		
			13					0.5	0.7	0.9	1.3		
			16						0.7	0.9	1.3		
			20							0.9	1.3		
			25								0.9	1.3	
			32									0.8	1.1

L.	Char.	E.		S800 S									
		Icu [kA]	B										
			In [A]	25	32	40	50	63	80	100	125		
S 200 P	K	25	0.2	T	T	T	T	T	T	T	T	T	T
			0.3	T	T	T	T	T	T	T	T	T	
			0.5	T	T	T	T	T	T	T	T	T	
			0.75	T	T	T	T	T	T	T	T	T	
			1	0.8	5	T	T	T	T	T	T		
			1.6	0.5	1	2.3	T	T	T	T	T		
			2	0.3	0.5	0.7	2.1	T	T	T	T		
		15	3		0.4	0.5	0.7	1.2	2.5	8.6	T		
			4		0.4	0.4	0.7	1	1.7	3	7.7		
			6			0.6	0.8	1.2	2	3.6			
			8				0.7	0.9	1.3	2			
			10					0.9	1.3	2			
			13							1	1.5		
			16								1.5		

L.	Char.	E.		S800 S									
		Icu [kA]	C										
			In [A]	25	32	40	50	63	80	100	125		
S 200 P	K	25	0.2	T	T	T	T	T	T	T	T	T	
			0.3	T	T	T	T	T	T	T	T		
			0.5	T	T	T	T	T	T	T	T		
			0.75	T	T	T	T	T	T	T	T		
			1	0.8	5	T	T	T	T	T	T		
			1.6	0.5	1	2.3	T	T	T	T	T		
			2	0.3	0.5	0.7	2.3	T	T	T	T		
		15	3		0.4	0.5	0.7	1.2	2.5	8.6	T		
			4		0.4	0.4	0.7	1	1.7	3	7.7		
			6			0.6	0.8	1.2	2	3.6			
			8				0.7	0.9	1.3	2			
			10					0.9	1.3	2			
			13							1	1.5		
			16								1.5		

System pro M compact®

Technical details

Coordination tables: selectivity

L.	Char.	E.		S800 S																	
		Icu [kA]	D																		
			In [A]	25	32	40	50	63	80	100	125										
S 200 P	B	25	6	0.5	1	1.2	2	2.8	9.9	21.3	T										
			10	0.4	0.6	0.8	1.1	1.4	2.8	3.9	7.4										
			13	0.4	0.6	0.8	1.1	1.4	2.5	3.3	5.6										
			16		0.6	0.8	1.1	1.4	2.5	3.3	5.6										
			20			0.8	1.1	1.3	2.3	3	4.7										
			25			0.8	1.1	1.3	2.3	3	4.7										
			32				0.9	1.1	1.9	2.4	3.7										
		15	40					1.1	1.9	2.4	3.7										
			50						1.5	1.9	2.3										
			63							1.7	2.3										

L.	Char.	E.		S800 S																	
		Icu [kA]	D																		
			In [A]	25	32	40	50	63	80	100	125										
S 200 P	C	25	0.5	T	T	T	T	T	T	T	T	T	T	T	T	T	T	T	T	T	
			1	T	T	T	T	T	T	T	T	T	T	T	T	T	T	T	T	T	
			1.6	T	T	T	T	T	T	T	T	T	T	T	T	T	T	T	T	T	T
			2	T	T	T	T	T	T	T	T	T	T	T	T	T	T	T	T	T	T
			3	0.7	2.2	4.4	T	T	T	T	T	T	T	T	T	T	T	T	T	T	T
			4	0.7	1.3	2.2	4.4	7.7	T	T	T	T	T	T	T	T	T	T	T	T	T
			6	0.5	1	1.2	2	2.8	9.9	22	T	T	T	T	T	T	T	T	T	T	T
			8	0.4	0.6	0.8	1.1	1.4	2.8	3.9	7.4	T	T	T	T	T	T	T	T	T	T
			10	0.4	0.6	0.8	1.1	1.4	2.8	3.9	7.4	T	T	T	T	T	T	T	T	T	T
			13	0.4	0.6	0.8	1.1	1.4	2.5	3.3	5.6	T	T	T	T	T	T	T	T	T	T
		16		0.6	0.8	1.1	1.4	2.5	3.3	5.6	T	T	T	T	T	T	T	T	T	T	
		20			0.8	1.1	1.3	2.3	3	4.7	T	T	T	T	T	T	T	T	T	T	
		25			0.8	1.1	1.3	2.3	3	4.7	T	T	T	T	T	T	T	T	T	T	
		15	32				0.9	1.1	1.9	2.4	3.7	T	T	T	T	T	T	T	T	T	
			40					1.1	1.9	2.4	3.7	T	T	T	T	T	T	T	T	T	
			50						1.5	1.9	2.3	T	T	T	T	T	T	T	T	T	
			63							1.7	2.3	T	T	T	T	T	T	T	T	T	

L.	Char.	E.		S800 S																	
		Icu [kA]	D																		
			In [A]	25	32	40	50	63	80	100	125										
S 200 P	K	25	0.2	T	T	T	T	T	T	T	T	T	T	T	T	T	T	T	T	T	
			0.3	T	T	T	T	T	T	T	T	T	T	T	T	T	T	T	T	T	
			0.5	T	T	T	T	T	T	T	T	T	T	T	T	T	T	T	T	T	T
			0.75	T	T	T	T	T	T	T	T	T	T	T	T	T	T	T	T	T	T
			1	T	T	T	T	T	T	T	T	T	T	T	T	T	T	T	T	T	T
			1.6	T	T	T	T	T	T	T	T	T	T	T	T	T	T	T	T	T	T
			2	2.3	T	T	T	T	T	T	T	T	T	T	T	T	T	T	T	T	T
			3	0.7	1.3	4.4	T	T	T	T	T	T	T	T	T	T	T	T	T	T	T
			4	0.7	1	2.2	4.4	7.7	T	T	T	T	T	T	T	T	T	T	T	T	T
			6	0.6	0.8	1.5	2.5	3.6	12.1	24.2	T	T	T	T	T	T	T	T	T	T	T
		8	0.5	0.7	1.1	1.5	2	4	5.5	9.9	T	T	T	T	T	T	T	T	T	T	
		10	0.5	0.7	1.1	1.5	2	4	5.5	9.9	T	T	T	T	T	T	T	T	T	T	
		13		0.6	0.9	1.2	1.5	2.6	3.4	5.2	T	T	T	T	T	T	T	T	T	T	
		16			0.9	1.2	1.5	2.6	3.4	5.2	T	T	T	T	T	T	T	T	T	T	
		20				0.9	1.1	1.8	2.2	3.2	T	T	T	T	T	T	T	T	T	T	
		25						1.8	2.2	3.2	T	T	T	T	T	T	T	T	T	T	
		15	32						1.7	2	2.9	T	T	T	T	T	T	T	T	T	
			40							1.9	2.6	T	T	T	T	T	T	T	T	T	
			50								2.2	T	T	T	T	T	T	T	T	T	
			63									2.2	T	T	T	T	T	T	T	T	

S800 N - S 200 P @230/400 V

L.	Char.	Icu [kA]	S800 N												
			In [A]	B											
				25	32	40	50	63	80	100	125				
S 200 P	B	25	6			0.4	0.5	0.7	1	1.5	2.6				
			10				0.4	0.6	0.7	1	1.4				
			13					0.5	0.7	0.9	1.3				
			16						0.7	0.9	1.3				
			20							0.9	1.3				
			25								0.9	1.3			
			32									0.8	1.1		
	15	40									0.8	1.1			
		50										1			
		63											0.9		

L.	Char.	Icu [kA]	S800 N												
			In [A]	C											
				25	32	40	50	63	80	100	125				
S 200 P	B	25	6				0.4	0.5	0.7	1	1.5	2.6			
			10					0.4	0.6	0.7	1	1.4			
			13						0.5	0.7	0.9	1.3			
			16							0.7	0.9	1.3			
			20								0.9	1.3			
			25									0.9	1.3		
			32										0.8	1.1	
	15	40										0.8	1.1		
		50											1		
		63												0.9	

L.	Char.	Icu [kA]	S800 N												
			In [A]	B											
				25	32	40	50	63	80	100	125				
S 200 P	C	25	0.5	T	T	T	T	T	T	T	T	T	T	T	
			1	3.3	T	T	T	T	T	T	T	T	T	T	
			1.6	0.6	1.3	T	T	T	T	T	T	T	T	T	
			2	0.4	0.7	1.3	T	T	T	T	T	T	T	T	
			3		0.4	0.6	0.7	1.1	2.6	8.8	T	T	T	T	
			4		0.4	0.6	0.7	1	1.7	3.1	7	T	T	T	
			6			0.4	0.5	0.7	1	1.5	2.6	T	T	T	
			8				0.4	0.6	0.7	1	1.4	T	T	T	
			10					0.4	0.6	0.7	1	1.4	T	T	
			13						0.5	0.7	0.9	1.3	T	T	
			16							0.7	0.9	1.3	T	T	
			20								0.9	1.3	T	T	
			25									0.9	1.3	T	T
			32										0.8	1.1	T
40											0.8	1.1	T	T	
50												1	T	T	
63													0.9	T	T

L.	Char.	Icu [kA]	S800 N												
			In [A]	C											
				25	32	40	50	63	80	100	125				
S 200 P	C	25	0.5	T	T	T	T	T	T	T	T	T	T	T	
			1	3.3	T	T	T	T	T	T	T	T	T	T	
			1.6	0.6	1.3	T	T	T	T	T	T	T	T	T	
			2	0.4	0.7	1.3	T	T	T	T	T	T	T	T	
			3		0.4	0.6	0.7	1.1	2.6	8.8	T	T	T	T	
			4		0.4	0.6	0.7	1	1.7	3.1	7	T	T	T	
			6			0.4	0.5	0.7	1	1.5	2.6	T	T	T	
			8				0.4	0.6	0.7	1	1.4	T	T	T	
			10					0.4	0.6	0.7	1	1.4	T	T	
			13						0.5	0.7	0.9	1.3	T	T	
			16							0.7	0.9	1.3	T	T	
			20								0.9	1.3	T	T	
			25									0.9	1.3	T	T
			32										0.8	1.1	T
40											0.8	1.1	T	T	
50												1	T	T	
63													0.9	T	T

L.	Char.	Icu [kA]	S800 N													
			In [A]	B												
				25	32	40	50	63	80	100	125					
S 200 P	K	25	0.2	T	T	T	T	T	T	T	T	T	T	T		
			0.3	T	T	T	T	T	T	T	T	T	T	T		
			0.5	T	T	T	T	T	T	T	T	T	T	T		
			0.75	T	T	T	T	T	T	T	T	T	T	T		
			1	0.8	5	T	T	T	T	T	T	T	T	T		
			1.6	0.5	1	2.3	T	T	T	T	T	T	T	T		
			2	0.3	0.5	0.7	2.1	T	T	T	T	T	T	T		
			3		0.4	0.5	0.7	1.2	2.5	8.6	T	T	T	T		
			4		0.4	0.4	0.7	1	1.7	3	7.7	T	T	T		
			6				0.6	0.8	1.2	2	3.6	T	T	T		
			8					0.7	0.9	1.3	2	T	T	T		
			10						0.9	1.3	2	T	T	T		
			13								1	1.5	T	T		
			16									1.5	T	T		
20										T	T					
25											T	T				
32												T	T			
40													T	T		
50														T	T	
63															T	T

L.	Char.	Icu [kA]	S800 N													
			In [A]	C												
				25	32	40	50	63	80	100	125					
S 200 P	K	25	0.2	T	T	T	T	T	T	T	T	T	T	T		
			0.3	T	T	T	T	T	T	T	T	T	T	T		
			0.5	T	T	T	T	T	T	T	T	T	T	T		
			0.75	T	T	T	T	T	T	T	T	T	T	T		
			1	0.8	5	T	T	T	T	T	T	T	T	T		
			1.6	0.5	1	2.3	T	T	T	T	T	T	T	T		
			2	0.3	0.5	0.7	2.3	T	T	T	T	T	T	T		
			3		0.4	0.5	0.7	1.2	2.5	8.6	T	T	T	T		
			4		0.4	0.4	0.7	1	1.7	3	7.7	T	T	T		
			6				0.6	0.8	1.2	2	3.6	T	T	T		
			8					0.7	0.9	1.3	2	T	T	T		
			10						0.9	1.3	2	T	T	T		
			13								1	1.5	T	T		
			16									1.5	T	T		
20										T	T					
25											T	T				
32												T	T			
40													T	T		
50														T	T	
63															T	T

System pro M compact®

Technical details

Coordination tables: selectivity

L.	Char.	E.		S800 N																		
		Icu [kA]	D																			
			In [A]	25	32	40	50	63	80	100	125											
S 200 P	B	25	6	0.5	1	1.2	2	2.8	9.9	21.3	T											
			10	0.4	0.6	0.8	1.1	1.4	2.8	3.9	7.4											
			13	0.4	0.6	0.8	1.1	1.4	2.5	3.3	5.6											
			16		0.6	0.8	1.1	1.4	2.5	3.3	5.6											
			20			0.8	1.1	1.3	2.3	3	4.7											
			25			0.8	1.1	1.3	2.3	3	4.7											
			32				0.9	1.1	1.9	2.4	3.7											
			40					1.1	1.9	2.4	3.7											
			50						1.5	1.9	2.3											
			63							1.7	2.3											

L.	Char.	E.		S800 N																		
		Icu [kA]	D																			
			In [A]	25	32	40	50	63	80	100	125											
S 200 P	C	25	0.5	T	T	T	T	T	T	T	T	T	T	T	T	T	T	T	T	T	T	
			1	T	T	T	T	T	T	T	T	T	T	T	T	T	T	T	T	T	T	T
			1.6	T	T	T	T	T	T	T	T	T	T	T	T	T	T	T	T	T	T	T
			2	T	T	T	T	T	T	T	T	T	T	T	T	T	T	T	T	T	T	T
			3	0.7	2.2	4.4	T	T	T	T	T	T	T	T	T	T	T	T	T	T	T	T
			4	0.7	1.3	2.2	4.4	7.7	T	T	T	T	T	T	T	T	T	T	T	T	T	T
			6	0.5	1	1.2	2	2.8	9.9	22	T	T	T	T	T	T	T	T	T	T	T	T
			8	0.4	0.6	0.8	1.1	1.4	2.8	3.9	7.4	T	T	T	T	T	T	T	T	T	T	T
			10	0.4	0.6	0.8	1.1	1.4	2.8	3.9	7.4	T	T	T	T	T	T	T	T	T	T	T
			13	0.4	0.6	0.8	1.1	1.4	2.5	3.3	5.6	T	T	T	T	T	T	T	T	T	T	T
			16		0.6	0.8	1.1	1.4	2.5	3.3	5.6	T	T	T	T	T	T	T	T	T	T	T
			20			0.8	1.1	1.3	2.3	3	4.7	T	T	T	T	T	T	T	T	T	T	T
			25			0.8	1.1	1.3	2.3	3	4.7	T	T	T	T	T	T	T	T	T	T	T
			32				0.9	1.1	1.9	2.4	3.7	T	T	T	T	T	T	T	T	T	T	T
			40					1.1	1.9	2.4	3.7	T	T	T	T	T	T	T	T	T	T	T
			50						1.5	1.9	2.3	T	T	T	T	T	T	T	T	T	T	T
			63							1.7	2.3	T	T	T	T	T	T	T	T	T	T	T

L.	Char.	E.		S800 N																		
		Icu [kA]	D																			
			In [A]	25	32	40	50	63	80	100	125											
S 200 P	K	25	0.2	T	T	T	T	T	T	T	T	T	T	T	T	T	T	T	T	T	T	
			0.3	T	T	T	T	T	T	T	T	T	T	T	T	T	T	T	T	T	T	
			0.5	T	T	T	T	T	T	T	T	T	T	T	T	T	T	T	T	T	T	T
			0.75	T	T	T	T	T	T	T	T	T	T	T	T	T	T	T	T	T	T	T
			1	T	T	T	T	T	T	T	T	T	T	T	T	T	T	T	T	T	T	T
			1.6	T	T	T	T	T	T	T	T	T	T	T	T	T	T	T	T	T	T	T
			2	2.3	T	T	T	T	T	T	T	T	T	T	T	T	T	T	T	T	T	T
			3	0.7	1.3	4.4	T	T	T	T	T	T	T	T	T	T	T	T	T	T	T	T
			4	0.7	1	2.2	4.4	7.7	T	T	T	T	T	T	T	T	T	T	T	T	T	T
			6	0.6	0.8	1.5	2.5	3.6	12.1	24.2	T	T	T	T	T	T	T	T	T	T	T	T
			8	0.5	0.7	1.1	1.5	2	4	5.5	9.9	T	T	T	T	T	T	T	T	T	T	T
			10	0.5	0.7	1.1	1.5	2	4	5.5	9.9	T	T	T	T	T	T	T	T	T	T	T
			13		0.6	0.9	1.2	1.5	2.6	3.4	5.2	T	T	T	T	T	T	T	T	T	T	T
			16			0.9	1.2	1.5	2.6	3.4	5.2	T	T	T	T	T	T	T	T	T	T	T
			20				0.9	1.1	1.8	2.2	3.2	T	T	T	T	T	T	T	T	T	T	T
			25					1.1	1.8	2.2	3.2	T	T	T	T	T	T	T	T	T	T	T
			32						1.7	2	2.9	T	T	T	T	T	T	T	T	T	T	T
			40							1.9	2.6	T	T	T	T	T	T	T	T	T	T	T
			50								2.2	T	T	T	T	T	T	T	T	T	T	T
			63									2.2	T	T	T	T	T	T	T	T	T	T

MCB S 700 - fuse gL/gG

Short circuit selectivity: In the case of a short circuit, selectivity exists up to the values indicated.

short circuit discrimination in kA

	I _n A	to main circuit breaker S 700								to fuse gL/gG (DIN VDE 0636; IEC 269/3)										
		16	20	25	35	40	50	63	80	100	16	20	25	35	50	63	80	100	125	160
S 200	2	15	15	15	15	15	15	15	15	15	1	1.2	4	15	15	15	15	15	15	15
B, C, D	3	10	10	10	10	10	10	10	8	8	0.3	0.7	1.2	4.6	6	6	6	6	6	6
Current values smaller than 6 A and 8 A, apply only to C and D characteristics	4	10	10	10	10	10	10	10	8	8	0.3	0.6	0.9	2.8	6	6	6	6	6	6
	6	10	10	10	10	10	10	10	8	8	0.2	0.5	0.8	2	3.3	5.5	6	6	6	6
	8	10	10	10	10	10	10	10	8	8	0.2	0.4	0.7	1.7	2.8	4.5	6	6	6	6
	10	10	10	10	10	10	10	10	8	8	0.2	0.4	0.7	1.5	2.5	3.5	5	6	6	6
	13	10	10	10	10	10	10	10	8	8			0.7	1.5	2.5	3.5	5	6	6	6
	16	10	10	10	10	10	10	10	8	8				1.3	2	2.9	4.1	6	6	6
	20		10	10	10	10	10	10	8	8					1.8	2.6	3.5	5	6	6
	25			10	10	10	10	10	8	8					1.8	2.6	3.5	5	6	6
	32				10	10	10	10	8	8						2.2	3	4	6	6
	40		**			10	10	10	8	8						2.5	4	6	6	6
	50/63						10	10	8	8								3.5	5	6
S 200 M	2	15	15	15	15	15	15	15	15	15	1	1.2	4	15	15	15	15	15	15	
B, C	3	15	15	15	15	15	15	15	10	10	0.3	0.7	1.2	4.6	6	6	6	6	6	
Current values smaller than 6 A and 8 A, apply only to C characteristics	4	15	15	15	15	15	15	15	10	10	0.3	0.6	0.9	2.8	6	6	6	6	6	
	6	15	15	15	15	15	15	15	10	10	0.2	0.5	0.8	2	3.3	5.5	6	6	6	
	8	15	15	15	15	15	15	15	10	10	0.2	0.4	0.7	1.7	2.8	4.5	6	6	6	
	10	15	15	15	15	15	15	15	10	10	0.2	0.4	0.7	1.5	2.5	3.5	5	6	6	
	13	15	15	15	15	15	15	15	10	10			0.7	1.5	2.5	3.5	5	6	6	
	16	15	15	15	15	15	15	15	10	10				1.3	2	2.9	4.1	6	6	
	20		15	15	15	15	15	15	10	10					1.8	2.6	3.5	5	6	
	25			15	15	15	15	15	10	10					1.8	2.6	3.5	5	6	
	32				15	15	15	15	10	10						2.2	3	4	6	
	40		**			15	15	15	10	10						2.5	4	6	6	
	50/63						15	15	10	10								3.5	5	6
S 200	2	15	15	15	15	15	15	15	15	15	0.3	1.2	4	15	15	15	15	15	15	
K	3	10	10	10	10	10	10	10	10	10	0.3	0.7	1.2	4.6	6	6	6	6	6	
Selectivity values apply to I _{cu} according to IEC 947-2	4	10	10	10	10	10	10	10	10	10	0.3	0.6	0.9	2.8	6	6	6	6	6	
	6	10	10	10	10	10	10	10	10	10			0.7	1.7	3	5.9	6	6	6	
	8	10	10	10	10	10	10	10	10	10				1.3	2.2	3.6	6	6	6	
	10	10	10	10	10	10	10	10	10	10					1.7	2.5	4	6	6	
	16	10	10	10	10	10	10	10	10	10						2.2	3.1	4.6	6	
	20		10	10	10	10	10	10	10	10							3.1	4.6	6	
	25			10	10	10	15	10	10	10							2.6	3.5	6	
	32				10	10	10	10	10	10								3.5	6	
	40		**			10	10	10	10	10									5.5	
	50/63						10	10	10	10										6
	S 200	2	15	15	15	15	15	15	15	15	15	0.5	2	15	15	15	15	15	15	15
Z	3	10	10	10	10	10	10	10	10	10	0.3	0.7	1.2	6	6	6	6	6	6	
Selectivity values apply to I _{cu} according to IEC 947-2	4	10	10	10	10	10	10	10	10	10	0.3	0.6	1.3	7	6	6	6	6	6	
	6	10	10	10	10	10	10	10	10	10	0.2	0.5	0.9	2.7	6	6	6	6	6	
	8	10	10	10	10	10	10	10	10	10	0.2	0.5	0.6	1.7	3.8	6	6	6	6	
	10	10	10	10	10	10	10	10	10	10		0.4	0.6	1.3	2.4	4	6	6	6	
	16	10	10	10	10	10	10	10	10	10			0.5	1.1	1.7	3	4.5	6	6	
	20		10	10	10	10	10	10	10	10				0.9	1.5	2.3	3.5	5.2	6	
	25			10	10	10	15	10	10	10					1.4	2	3	4	6	
	32				10	10	10	10	10	10					1.4	2	3	4	6	
	40		**			10	10	10	10	10						2	3	4	6	
	50/63						10	10	10	10						2.2	3.5	5.8	6	

** Limited or no selectivity at all possible in the overload range (thermal tripping)

Tmax T1 - S 200 @ 400/415 V

		Supply s.						T1									
		Version						B-C-N									
		Release						TM									
		Iu [A]						160									
Load s.	Char.	Icu [kA]	In [A]	16	20	25	32	40	50	63	80	100	125	160			
S 200	C	10	≤ 2	T	T	T	T	T	T	T	T	T	T	T	T		
			3	T	T	T	T	T	T	T	T	T	T	T	T		
			4	T	T	T	T	T	T	T	T	T	T	T	T	T	
			6	5.5	5.5	5.5	5.5	5.5	5.5	5.5	5.5	T	T	T	T	T	
	B-C	10	8		5.5	5.5	5.5	5.5	5.5	5.5	5.5	T	T	T	T		
			10			3	3	3	3	4.5	7.5	8.5	T	T	T		
			13				3	3	3	4.5	7.5	7.5	T	T	T		
			16					3	3	4.5	5	7.5	T	T	T		
			20							3	5	6	T	T	T		
			25								5	6	T	T	T		
			32									6	7.5	T	T		
			40										7.5	T	T		
			50											7.5	T		
			63												7.5	T	
			D	10	≤ 2	T	T	T	T	T	T	T	T	T	T	T	T
					3	T	T	T	T	T	T	T	T	T	T	T	T
					4	T	T	T	T	T	T	T	T	T	T	T	T
					6	5.5	5.5	5.5	5.5	5.5	5.5	5.5	5.5	T	T	T	T
	8				5.5	5.5	5.5	5.5	5.5	5.5	5.5	T	T	T	T		
	10					3	3	3	3	3	5	8.5	T	T	T		
	13								2	2	3	5	8	T	T		
	16								2	2	3	5	8	T	T		
	20									2	3	4.5	6.5	T	T		
	25										2.5	4	6	9.5	T		
	32											4	6	9.5	T		
	40												5	8	T		
	50													5	9.5		
	63														9.5		
	K	10	≤ 2	T	T	T	T	T	T	T	T	T	T	T	T		
			3	T	T	T	T	T	T	T	T	T	T	T	T		
			4	T	T	T	T	T	T	T	T	T	T	T	T		
			6	5.5	5.5	5.5	5.5	5.5	5.5	5.5	5.5	T	T	T	T		
			8		5.5	5.5	5.5	5.5	5.5	5.5	5.5	T	T	T	T		
			10			3	3	3	3	3	6	8.5	T	T	T		
			16						3	3	4.5	7.5	T	T	T		
			20							3	3.5	5.5	6.5	T	T		
			25								3.5	5.5	6	9.5	T		
			32									4.5	6	9.5	T		
			40										5	8	T		
			50											6	9.5		
			63												9.5		
			Z	10	≤ 2	T	T	T	T	T	T	T	T	T	T	T	T
	3	T			T	T	T	T	T	T	T	T	T	T	T		
	4	T			T	T	T	T	T	T	T	T	T	T	T		
	6	5.5			5.5	5.5	5.5	5.5	5.5	5.5	5.5	T	T	T	T		
	8				5.5	5.5	5.5	5.5	5.5	5.5	5.5	T	T	T	T		
	10					3	3	3	3	3	4.5	8	8.5	T	T		
	16								3	3	4.5	5	7.5	T	T		
20									3	5	6	T	T	T			
25										5	6	T	T	T			
32											6	7.5	T	T			
40												7.5	T	T			
50													7.5	T			
63														7.5			

Tmax T1 - S 200 M @ 400/415 V

		Supply s.			T1											
		Version			B-C-N											
		Release			TM											
		Iu [A]			160											
Load s.	Char.	Icu [kA]	In [A]	16	20	25	32	40	50	63	80	100	125	160		
S 200 M	C	15	≤ 2	T	T	T	T	T	T	T	T	T	T	T	T	
			3	T	T	T	T	T	T	T	T	T	T	T	T	
			4	T	T	T	T	T	T	T	T	T	T	T	T	T
			6	5.5	5.5	5.5	5.5	5.5	5.5	5.5	10.5	T	T	T	T	T
	B-C	15	8		5.5	5.5	5.5	5.5	5.5	5.5	10.5	T	T	T	T	
			10			3	3	3	4.5	7.5	8.5	T	T	T	T	
			13				3	3	4.5	7.5	7.5	12	T	T	T	
			16					3	4.5	5	7.5	12	T	T	T	
			20						3	5	6	10	T	T	T	
			25							5	6	10	T	T	T	
			32								6	7.5	12	T	T	
			40									7.5	12	T	T	
			50										7.5	10.5	T	
			63											10.5	T	
			D	15	≤ 2	T	T	T	T	T	T	T	T	T	T	T
	3	T			T	T	T	T	T	T	T	T	T	T	T	
	4	T			T	T	T	T	T	T	T	T	T	T	T	
	6	5.5			5.5	5.5	5.5	5.5	5.5	10.5	T	T	T	T	T	
	8				5.5	5.5	5.5	5.5	5.5	10.5	12	T	T	T	T	
	10					3	3	3	3	5	8.5	T	T	T	T	
	16							2	2	3	5	8	13.5	T	T	
	20								2	3	4.5	6.5	11	T	T	
	25									2.5	4	6	9.5	T	T	
	32										4	6	9.5	T	T	
	40											5	8	T	T	
	K	15	≤ 2	T	T	T	T	T	T	T	T	T	T	T	T	
			3	T	T	T	T	T	T	T	T	T	T	T	T	
			4	T	T	T	T	T	T	T	T	T	T	T	T	
			6	5.5	5.5	5.5	5.5	5.5	5.5	10.5	T	T	T	T	T	
			8		5.5	5.5	5.5	5.5	5.5	10.5	12	T	T	T	T	
			10			3	3	3	3	6	8.5	T	T	T	T	
			16					3	3	4.5	7.5	10	13.5	T	T	
			20						3	3.5	5.5	6.5	11	T	T	
25									3.5	5.5	6	9.5	T	T		
32										4.5	6	9.5	T	T		
40											5	8	T	T		
50										6	9.5	T				
63											9.5	T				

Tmax T1 - S 200 P @ 400/415 V

		Supply s.			T1												
		Version			B-C-N												
		Release			TM												
		Iu [A]			160												
Load s.	Char.	Icu [kA]	In [A]	16	20	25	32	40	50	63	80	100	125	160			
S 200 P	C	25	≤ 2	T	T	T	T	T	T	T	T	T	T	T	T		
			3	15	15	15	15	15	15	15	15	15	17*	T	T		
			4	15	15	15	15	15	15	15	15	15	15	17*	T	T	
			6	5.5	5.5	5.5	5.5	5.5	5.5	5.5	5.5	10.5	15	17*	T	T	
	B-C	25	8		5.5	5.5	5.5	5.5	5.5	5.5	5.5	10.5	15	17*	T	T	
			10				3	3	3	3	4.5	7.5	8.5	17*	T	T	
			13					3	3	3	4.5	7.5	7.5	12	20*	T	
			16						3	4.5	5	7.5	12	20*	T		
			20							3	5	6	10	15	T		
			25								5	6	10	15	T		
			32									6	7.5	12	T		
			40										7.5	12	T		
			50											7.5	10.5		
			63												10.5		
	D	25	≤ 2	T	T	T	T	T	T	T	T	T	T	T	T		
			3	15	15	15	15	15	15	15	15	15	15	17*	T	T	
			4	15	15	15	15	15	15	15	15	15	15	17*	T	T	
			6	5.5	5.5	5.5	5.5	5.5	5.5	5.5	5.5	10.5	15	17*	T	T	
			8		5.5	5.5	5.5	5.5	5.5	5.5	5.5	10.5	12	17*	T	T	
			10				3	3	3	3	3	5	8.5	17*	T	T	
			13						2	2	3	5	8	13.5	T		
			16						2	2	3	5	8	13.5	T		
		20							2	3	4.5	6.5	11	T			
		25								2.5	4	6	9.5	T			
		15	32									4	6	9.5	T		
			40										5	8	T		
			50											5	9.5		
			63												9.5		
			K	25	≤ 2	T	T	T	T	T	T	T	T	T	T	T	T
					3	15	15	15	15	15	15	15	15	15	15	17*	T
	4				15	15	15	15	15	15	15	15	15	15	17*	T	T
	6				5.5	5.5	5.5	5.5	5.5	5.5	5.5	5.5	10.5	15	17*	T	T
	8				5.5	5.5	5.5	5.5	5.5	5.5	5.5	10.5	12	17*	T	T	
10						3	3	3	3	3	6	8.5	17*	T	T		
13								3	3	5	7.5	10	13.5	T			
16								3	3	4.5	7.5	10	13.5	T			
20								3	3.5	5.5	6.5	11	T				
25									3.5	5.5	6	9.5	T				
15	32										4.5	6	9.5	T			
	40											5	8	T			
	50												6	9.5			
	63													9.5			
	Z	25		≤ 2	T	T	T	T	T	T	T	T	T	T	T	T	
				3	15	15	15	15	15	15	15	15	15	15	17*	T	T
			4	15	15	15	15	15	15	15	15	15	15	17*	T	T	
			6	5.5	5.5	5.5	5.5	5.5	5.5	5.5	5.5	10.5	15	17*	T	T	
8				5.5	5.5	5.5	5.5	5.5	5.5	5.5	10.5	12	17*	T	T		
10						3	3	3	3	4.5	8	8.5	17*	T	T		
16								3	4.5	5	7.5	12	20*	T			
20									3	5	6	10	15	T			
25									5	6	10	15	T				
15		32										6	7.5	12	T		
		40											7.5	12	T		
		50												7.5	10.5		
		63													10.5		

* Select the lowest value between with is indicated and the breaking capacity of the supply side circuit-breaker.

Tmax T1 - S 800 S @400/415 V

L.	Char.	Icu [kA]	E.		T1												
			A.		B, C, N												
			Release		TM												
			Iu [A]		160												
			In [A]	16	20	25	32	40	50	63	80	100	125	160			
S 800 S	B, C, D, K	50	10			4.5	4.5	4.5	4.5	8	10	20*	25*	36*			
			13			4.5	4.5	4.5	7.5	10	15	25*	36*				
			16				4.5	4.5	7.5	10	15	25*	36*				
			20					4.5	7.5	10	15	25*	36*				
			25						6	10	15	20*	36*				
			32							7.5	10	20*	36*				
			40								10	20*	36*				
			50									15	36*				
			63										36*				
			80										36*				
			100										36*				
			125											36*			

Tmax T1 - S 800 N @400/415 V

L.	Char.	Icu [kA]	E.		T1												
			A.		B, C, N												
			Release		TM												
			Iu [A]		160												
			In [A]	16	20	25	32	40	50	63	80	100	125	160			
S 800 N	B, C, D	36	10			4.5	4.5	4.5	4.5	8	10	20*	25*	36*			
			13			4.5	4.5	4.5	7.5	10	15	25*	36*				
			16				4.5	4.5	7.5	10	15	25*	36*				
			20					4.5	7.5	10	15	25*	36*				
			25						6	10	15	20*	36*				
			32							7.5	10	20*	36*				
			40								10	20*	36*				
			50									15	36*				
			63										36*				
			80										36*				
			100										36*				
			125											36*			

E. = supply side L. = load side
T = total selectivity up to breaking capacity of load side breaker
Selectivity limits are specified in kA

System pro M compact®

Technical details

Coordination tables: selectivity

MCBs

Tmax T2 - S 200 @ 400/415 V

		Supply s.		T2																		
		Version		N-S-H-L																		
		Release		TM-M										EL								
		I _{cu} [kA]		160																		
		I _n [A]		12.5	16	20	25	32	40	50	63	80	100	125	160	10	25	63	100	160		
Load s. S 200	C	10	≤ 2	T	T	T	T	T	T	T	T	T	T	T	T	T	T	T	T	T		
			3	T	T	T	T	T	T	T	T	T	T	T	T	T	T	T	T	T		
			4	T	T	T	T	T	T	T	T	T	T	T	T	T	T	T	T	T	T	
			6	5.5*	5.5	5.5	5.5	5.5	5.5	5.5	5.5	T	T	T	T	T	T	T	T	T	T	
	B-C	10	8			5.5	5.5	5.5	5.5	5.5	T	T	T	T	T	T	T	T	T	T		
			10			3*	3	3	3	4.5	7.5	8.5	T	T	T	T	T	T	T	T		
			13			3*		3	3	4.5	7.5	7.5	T	T	T	T	T	T	T	T		
			16					3*	3	4.5	5	7.5	T	T	T	T	T	T	T	T		
			20						3*		3	5	6	T	T	T	T	T	T	T		
			25								3*	5	6	T	T	T	T	T	T	T		
			32									3*	6	7.5	T	T	T	T	T	T		
			40										5.5*	7.5	T	T	T	T	T	T		
			50											3*	5*	7.5	T	T	T	T		
			63												5*		T	T	T	T		
			D	10	≤ 2	T	T	T	T	T	T	T	T	T	T	T	T	T	T	T	T	T
					3	T	T	T	T	T	T	T	T	T	T	T	T	T	T	T	T	T
	4	T			T	T	T	T	T	T	T	T	T	T	T	T	T	T	T	T		
	6	5.5*			5.5	5.5	5.5	5.5	5.5	5.5	5.5	T	T	T	T	T	T	T	T	T		
	8					5.5	5.5	5.5	5.5	5.5	5.5	T	T	T	T	T	T	T	T	T		
	10						3*	3	3	3	3	5	8.5	T	T	T	T	T	T	T		
	13								2*	2	2	3	5	8	T	T	T	T	T	T		
	16									2*	2	2	3	5	8	T	T	T	T	T		
	20										2*	2	3	4.5	6.5	T	T	T	T	T		
	25											2*	2.5	4	6	9.5	T	T	T	T		
	32													4	6	9.5	T	T	T	T		
	40													3*	5	8	T	T	T	T		
	50												2*	3*	5	9.5	9.5	9.5				
	63													3*	9.5	9.5	9.5					
	K	10	≤ 2	T	T	T	T	T	T	T	T	T	T	T	T	T	T	T	T			
			3	T	T	T	T	T	T	T	T	T	T	T	T	T	T	T	T			
			4	T	T	T	T	T	T	T	T	T	T	T	T	T	T	T	T			
			6	5.5*	5.5	5.5	5.5	5.5	5.5	5.5	5.5	T	T	T	T	T	T	T	T			
			8			5.5	5.5	5.5	5.5	5.5	5.5	T	T	T	T	T	T	T	T			
			10				3*	3	3	3	3	6	8.5	T	T	T	T	T	T			
			16					2*	3	3	4.5	7.5	T	T	T	T	T	T	T			
			20						2*		3	3.5	5.5	6.5	T	T	T	T	T			
			25									2*	3.5	5.5	6	9.5	T	T	T			
			32											4.5	6	9.5	T	T	T			
			40												3*	5	8	T	T			
			50													2*	3*	6	9.5	9.5		
	63														3*	9.5	9.5					
	Z	10	≤ 2	T	T	T	T	T	T	T	T	T	T	T	T	T	T	T	T			
			3	T	T	T	T	T	T	T	T	T	T	T	T	T	T	T	T			
			4	T	T	T	T	T	T	T	T	T	T	T	T	T	T	T	T			
			6	5.5*	5.5	5.5	5.5	5.5	5.5	5.5	5.5	T	T	T	T	T	T	T	T			
			8			5.5	5.5	5.5	5.5	5.5	5.5	T	T	T	T	T	T	T	T			
			10				3*	3	3	3	4.5	8	8.5	T	T	T	T	T	T			
			16					3*	3	4.5	5	7.5	T	T	T	T	T	T	T			
20								3*		3	5	6	T	T	T	T	T	T				
25											3*	5	6	T	T	T	T	T				
32												3*	6	7.5	T	T	T	T				
40													5.5*	7.5	T	T	T	T				
50														4*	5*	7.5	T	T				
63													5*	T	T	T						

* Value valid with supply side magnetic only circuit-breaker.

Tmax T2 - S 200 M @ 400/415 V

		Supply s.		T2																	
		Version		N-S-H-L																	
		Release		TM-M												EL					
		I _u [A]		160																	
Load s.	Char.	I _{cu} [kA]	I _n [A]	12.5	16	20	25	32	40	50	63	80	100	125	160	10	25	63	100	160	
S 200 M	C	15	≤ 2	T	T	T	T	T	T	T	T	T	T	T	T	T	T	T	T	T	T
			3	T	T	T	T	T	T	T	T	T	T	T	T	T	T	T	T	T	T
			4	T	T	T	T	T	T	T	T	T	T	T	T	T	T	T	T	T	T
	B-C	15	6	5.5*	5.5	5.5	5.5	5.5	5.5	5.5	5.5	10.5	T	T	T	T	T	T	T	T	T
			8		5.5	5.5	5.5	5.5	5.5	10.5	T	T	T	T	T	T	T	T			
			10		3*	3	3	3	4.5	7.5	8.5	T	T	T	T	T	T	T			
			13		3*		3	3	4.5	7.5	7.5	12	T	T	T	T	T	T			
			16				3*	3	4.5	5	7.5	12	T	T	T	T	T				
			20					3*	3	5	6	10	T	T	T	T	T				
			25						3*	5	6	10	T	T	T	T	T				
			32							3*	6	7.5	12	T	T	T	T				
			40								5.5*	7.5	12	T	T	T	T				
			50									3*	5*	7.5	10.5	10.5	10.5				
	63											5*	10.5	10.5							
	D	15	≤ 2	T	T	T	T	T	T	T	T	T	T	T	T	T	T	T	T	T	T
			3	T	T	T	T	T	T	T	T	T	T	T	T	T	T	T	T	T	T
			4	T	T	T	T	T	T	T	T	T	T	T	T	T	T	T	T	T	T
			6	5.5*	5.5	5.5	5.5	5.5	5.5	5.5	10.5	T	T	T	T	T	T	T	T		
			8		5.5	5.5	5.5	5.5	5.5	10.5	12	T	T	T	T	T	T	T			
			10		3*	3	3	3	3	5	8.5	T	T	T	T	T	T	T			
			16				2*	2	2	3	5	8	13.5	T	T	T	T				
			20					2*	2	3	4.5	6.5	11	T	T	T	T				
			25						2*	2.5	4	6	9.5	T	T	T	T				
			32								4	6	9.5	T	T	T	T				
	40									3*	5	8	T	T	T						
	50										2*	3*	5	9.5	9.5	9.5					
	63											3*	9.5	9.5							
	K	15	≤ 2	T	T	T	T	T	T	T	T	T	T	T	T	T	T	T	T	T	T
			3	T	T	T	T	T	T	T	T	T	T	T	T	T	T	T	T	T	T
			4	T	T	T	T	T	T	T	T	T	T	T	T	T	T	T	T	T	T
			6	5.5*	5.5	5.5	5.5	5.5	5.5	5.5	10.5	T	T	T	T	T	T	T	T		
			8		5.5	5.5	5.5	5.5	5.5	10.5	12	T	T	T	T	T	T	T			
			10		3*	3	3	3	3	6	8.5	T	T	T	T	T	T	T			
16						2*	3	3	4.5	7.5	10	13.5	T	T	T	T					
20							2*	3	3.5	5.5	6.5	11	T	T	T	T					
25								2*	3.5	5.5	6	9.5	T	T	T	T					
32										4.5	6	9.5	T	T	T	T					
40									3*	5	8	T	T	T							
50										2*	3*	6	9.5	9.5	9.5						
63											3*	9.5	9.5								

* Value valid with supply side magnetic only circuit-breaker.

Tmax T2 - S 200 P @ 400/415 V

Load s.	Supply s.		T2																	
	Char.	Icu [kA]	Version																	
			N-S-H-L																	
			Release										EL							
lu [A]	In [A]	12.5	16	20	25	32	40	50	63	80	100	125	160	10	25	63	100	160		
S 200 P	C	25	≤ 2	T	T	T	T	T	T	T	T	T	T	T	T	T	T	T	T	T
			3	15	15	15	15	15	15	15	15	15	17	T	T	T	T	T	T	T
			4	15	15	15	15	15	15	15	15	15	17	T	T	T	T	T	T	T
			6	5.5*	5.5	5.5	5.5	5.5	5.5	5.5	5.5	10.5	15	17	T	T	T	T	T	T
	B-C	25	8			5.5	5.5	5.5	5.5	5.5	10.5	15	17	T	T	T	T	T	T	
			10			3*	3	3	3	4.5	7.5	8.5	17	T	T	T	T	T	T	
			13				3*		3	3	4.5	7.5	7.5	12	20	T	T	T	T	
			16					3*	3	4.5	5	7.5	12	20	T	T	T	T	T	
			20						3*	3	5	6	10	15	T	T	T	T	T	
			25							3*	5	6	10	15	T	T	T	T	T	
			32								3*	6	7.5	12	T	T	T	T	T	
			40									5.5*	7.5	12	T	T	T	T	T	
			50									3*	5*	7.5	10.5	T	T	10.5	10.5	
			63										5*	10.5	T	T	10.5	10.5		
	D	25	≤ 2	T	T	T	T	T	T	T	T	T	T	T	T	T	T	T	T	T
			3	15	15	15	15	15	15	15	15	15	17	T	T	T	T	T	T	
			4	15	15	15	15	15	15	15	15	15	17	T	T	T	T	T	T	
			6	5.5*	5.5	5.5	5.5	5.5	5.5	5.5	10.5	15	17	T	T	T	T	T	T	
			8			5.5	5.5	5.5	5.5	5.5	10.5	12	17	T	T	T	T	T	T	
			10				3*	3	3	3	3	5	8.5	17	T	T	T	T	T	
			13					2*	2	2	3	5	8	13.5	T	T	T	T	T	
			16						2*	2	2	3	5	8	13.5	T	T	T	T	
			20							2*	2	3	4.5	6.5	11	T	T	T	T	
			25								2*	2.5	4	6	9.5	T	T	T	T	
15	32									4	6	9.5	T	T	T	T	T			
	40									3*	5	8	T	T	T	T	T			
	50									2*	3*	5	9.5	T	T	9.5	9.5			
	63										3*	9.5	T	T	9.5	9.5				
	K	25	≤ 2	T	T	T	T	T	T	T	T	T	T	T	T	T	T	T	T	
			3	15	15	15	15	15	15	15	15	15	17	T	T	T	T	T	T	
4			15	15	15	15	15	15	15	15	15	17	T	T	T	T	T	T		
6			5.5*	5.5	5.5	5.5	5.5	5.5	5.5	10.5	15	17	T	T	T	T	T	T		
8					5.5	5.5	5.5	5.5	5.5	10.5	12	17	T	T	T	T	T	T		
10						3*	3	3	3	3	6	8.5	17	T	T	T	T	T		
13							2*	3	3	5	7.5	10	13.5	T	T	T	T	T		
16								2*	3	3	4.5	7.5	10	13.5	T	T	T	T		
20									2*	3	3.5	5.5	6.5	11	T	T	T	T		
25										2*	3.5	5.5	6	9.5	T	T	T	T		
15	32									4.5	6	9.5	T	T	T	T	T			
	40									3*	5	8	T	T	T	T	T			
	50									2*	3*	6	9.5	T	T	9.5	9.5			
	63										3*	9.5	T	T	9.5	9.5				
	Z	25	≤ 2	T	T	T	T	T	T	T	T	T	T	T	T	T	T	T	T	
			3	15	15	15	15	15	15	15	15	15	17	T	T	T	T	T	T	
4			15	15	15	15	15	15	15	15	15	17	T	T	T	T	T	T		
6			5.5*	5.5	5.5	5.5	5.5	5.5	5.5	10.5	15	17	T	T	T	T	T	T		
8					5.5	5.5	5.5	5.5	5.5	10.5	15	17	T	T	T	T	T	T		
10						3*	3	3	3	4.5	8	8.5	17	T	T	T	T	T		
16							3*	3	4.5	5	7.5	12	20	T	T	T	T	T		
20								3*	3	5	6	10	15	T	T	T	T	T		
25									3*	5	6	10	15	T	T	T	T	T		
32										3*	6	7.5	12	T	T	T	T	T		
15	40									5.5*	7.5	12	T	T	T	T	T			
	50									4*	5*	7.5	10.5	T	T	10.5	10.5			
	63										5*	10.5	T	T	10.5	10.5				

* Value valid with supply side magnetic only circuit-breaker.

Tmax T2 - S 290 @ 400/415 V

			Supply s.	T2	
			Version	N, S, H, L	
			Release	TM, M	EL
			Iu [A]	160	
Load s.	Char.	Icu [kA]	In [A]	160	160
S 290	C-D-K	20 (15)*	80		4
	C-D-K		100		4
	C		125		4

*Only for D characteristic

Tmax T3 - S 200 @ 400/415 V

Load s.	Char.	Icu [kA]	Supply s.		T3							
			Version		N-S							
			Release		TM-M							
		Iu [A]	63	80	100	125	160	200	250			
S 200	C	10	≤ 2	T	T	T	T	T	T	T		
			3	T	T	T	T	T	T	T		
			4	T	T	T	T	T	T	T		
			6	T	T	T	T	T	T	T		
	B-C	10	8	T	T	T	T	T	T	T		
			10	7.5	8.5	T	T	T	T	T		
			13	7.5	7.5	T	T	T	T	T		
			16	5	7.5	T	T	T	T	T		
			20	5	6	T	T	T	T	T		
			25	5	6	T	T	T	T	T		
			32		6	7.5	T	T	T	T		
			40			7.5	T	T	T	T		
			50			5*	7.5	T	T	T		
			63			5*	6*	T	T	T		
			D	10	≤ 2	T	T	T	T	T	T	T
					3	T	T	T	T	T	T	T
	4	T			T	T	T	T	T	T		
	6	T			T	T	T	T	T	T		
	8	T			T	T	T	T	T	T		
	10	5			8.5	T	T	T	T	T		
	13	3			5	8	T	T	T	T		
	16	3			5	8	T	T	T	T		
	20	3			4.5	6.5	T	T	T	T		
	25	2.5			4	6	9.5	T	T	T		
	32				4	6	9.5	T	T	T		
	40					5	8	T	T	T		
	50					3*	5	9.5	T	T		
	63					3*	5*	9.5	T	T		
	K	10	≤ 2	T	T	T	T	T	T	T		
			3	T	T	T	T	T	T	T		
			4	T	T	T	T	T	T	T		
			6	T	T	T	T	T	T	T		
			8	T	T	T	T	T	T	T		
			10	6	8.5	T	T	T	T	T		
			16	4.5	7.5	T	T	T	T	T		
			20	3.5	5.5	6.5	T	T	T	T		
			25	3.5	5.5	6	9.5	T	T	T		
			32		4.5	6	9.5	T	T	T		
			40			5	8	T	T	T		
			50			3*	6	9.5	T	T		
			63			3*	5.5*	9.5	T	T		
			Z	10	≤ 2	T	T	T	T	T	T	T
	3	T			T	T	T	T	T	T		
	4	T			T	T	T	T	T	T		
	6	T			T	T	T	T	T	T		
	8	T			T	T	T	T	T	T		
	10	8			8.5	T	T	T	T	T		
	16	5			7.5	T	T	T	T	T		
20	5	6			T	T	T	T	T			
25	5	6			T	T	T	T	T			
32		6			7.5	T	T	T	T			
40					7.5	T	T	T	T			
50					5*	7.5	T	T	T			
63					5*	6*	T	T	T			

* Value valid with supply side magnetic only circuit-breaker.

System pro M compact®

Technical details

Coordination tables: selectivity

MCBs

Tmax T3 - S 200 M @ 400/415 V

		Supply s.			T3						
		Version			N-S						
		Release			TM-M						
		Iu [A]			250						
Load s.	Char.	Icu [kA]	In [A]	63	80	100	125	160	200	250	
S 200 M	C	15	≤ 2	T	T	T	T	T	T	T	
			3	T	T	T	T	T	T	T	
			4	T	T	T	T	T	T	T	
	B-C	15	6	10.5	T	T	T	T	T	T	T
			8	10.5	T	T	T	T	T	T	T
			10	7.5	8.5	T	T	T	T	T	T
			13	7.5	7.5	12	T	T	T	T	T
			16	5	7.5	12	T	T	T	T	T
			20	5	6	10	T	T	T	T	T
			25	5	6	10	T	T	T	T	T
			32		6	7.5	12	T	T	T	T
			40			7.5	12	T	T	T	T
			50			5*	7.5	10.5	T	T	T
			63			5*	6*	10.5	T	T	T
	D	15	≤ 2	T	T	T	T	T	T	T	T
			3	T	T	T	T	T	T	T	T
			4	T	T	T	T	T	T	T	T
			6	10.5	T	T	T	T	T	T	T
			8	10.5	12	T	T	T	T	T	T
			10	5	8.5	T	T	T	T	T	T
			16	3	5	8	13.5	T	T	T	T
			20	3	4.5	6.5	11	T	T	T	T
			25	2.5	4	6	9.5	T	T	T	T
			32		4	6	9.5	T	T	T	T
			40			5	8	T	T	T	T
	50			3*	5	9.5	T	T	T		
	63			3*	5*	9.5	T	T	T		
	K	15	≤ 2	T	T	T	T	T	T	T	T
			3	T	T	T	T	T	T	T	T
			4	T	T	T	T	T	T	T	T
			6	10.5	T	T	T	T	T	T	T
			8	10.5	12	T	T	T	T	T	T
			10	6	8.5	T	T	T	T	T	T
16			4.5	7.5	10	13.5	T	T	T	T	
20			3.5	5.5	6.5	11	T	T	T	T	
25			3.5	5.5	6	9.5	T	T	T	T	
32				4.5	6	9.5	T	T	T	T	
40					5	8	T	T	T	T	
50			3*	6	9.5	T	T	T			
63			3*	5.5*	9.5	T	T	T			

* Value valid with supply side magnetic only circuit-breaker.

11

System pro M compact®

Technical details

Coordination tables: selectivity

MCBs

Tmax T3 - S 200 P @ 400/415 V

		Supply s.					T3					
		Version					N-S					
		Release					TM-M					
		Iu [A]					250					
load s.	Char.	Icu [kA]	In [A]	63	80	100	125	160	200	250		
S 200 P	C	25	≤ 2	T	T	T	T	T	T	T		
			3	15	15	17	T	T	T	T		
			4	15	15	17	T	T	T	T		
			B-C	25	6	10.5	15	17	T	T	T	T
					8	10.5	15	17	T	T	T	T
					10	7.5	8.5	17	T	T	T	T
		13			7.5	7.5	12	20	T	T	T	
		16			5	7.5	12	20	T	T	T	
		20			5	6	10	15	T	T	T	
		15	25	25	5	6	10	15	T	T	T	
				32		6	7.5	12	T	T	T	
				40			7.5	12	T	T	T	
	50					5*	7.5	10.5	T	T		
	63					5*	6*	10.5	T	T		
	D			25	≤ 2	T	T	T	T	T	T	T
		3	15		15	T	T	T	T	T		
		4	15		15	T	T	T	T	T		
		6	10.5		15	T	T	T	T	T		
		8	10.5		12	T	T	T	T	T		
		10	5		8.5	T	T	T	T	T		
		15	25	13	3	5	8	13.5	T	T	T	
				16	3	5	8	13.5	T	T	T	
				20	3	4.5	6.5	11	T	T	T	
				25	2.5	4	6	9.5	T	T	T	
				32		4	6	9.5	T	T	T	
				40			5	8	T	T	T	
	K	25	50			3*	5	9.5	T	T		
			63			3*	5*	9.5	T	T		
			≤ 2	T	T	T	T	T	T	T		
			3	15	15	17	T	T	T	T		
			4	15	15	17	T	T	T	T		
			6	10.5	15	17	T	T	T	T		
		15	25	8	10.5	12	17	T	T	T	T	
				10	6	8.5	17	T	T	T	T	
				13	5	7.5	10	13.5	T	T	T	
				16	4.5	7.5	10	13.5	T	T	T	
				20	3.5	5.5	6.5	11	T	T	T	
				25	3.5	5.5	6	9.5	T	T	T	
	Z	25	32		4.5	6	9.5	T	T	T		
			40			5	8	T	T	T		
			50			3*	6	9.5	T	T		
			63			3*	5.5*	9.5	T	T		
			≤ 2	T	T	T	T	T	T	T		
			3	15	15	17	T	T	T	T		
	Z	25	4	15	15	17	T	T	T	T		
			6	10.5	15	17	T	T	T	T		
			8	10.5	15	17	T	T	T	T		
			10	8	8.5	17	T	T	T	T		
16			5	7.5	12	20	T	T	T			
20			5	6	10	15	T	T	T			
15		25	25	5	6	10	15	T	T	T		
			32		6	7.5	12	T	T	T		
			40			7.5	12	T	T	T		
			50			5*	7.5	10.5	T	T		
			63			5*	6*	10.5	T	T		

* Value valid with supply side magnetic only circuit-breaker.

Tmax T3 - S 290 @ 400/415 V

			Supply s.		T3		
			Version		N, S		
			Release		TM, M		
			Iu [A]		250		
Load s.	Char.	Icu [kA]	In [A]		160	200	250
S 290	C-D-K	20 (15)**	80	4*	10	15	
			100	4*	7.5*	15	
	C		125		7.5*		

* Value valid with supply side magnetic only circuit-breaker.

** Only for D characteristic

Tmax T3 - S 800 S @400/415 V

			E.		T3						
			A.		N, S						
			Release		TM						
			Iu [A]		250						
L.	Char.	Icu [kA]	In [A]		63	80	100	125	160	200	250
S 800 S	B, C, D, K	50	10	8	10	20	25	36	36	50*	
			13	7.5	10	15	25	36	36	50*	
			16	7.5	10	15	25	36	36	50*	
			20	7.5	10	15	25	36	36	50*	
			25	6	10	15	20	36	36	50*	
			32		7.5	10	20	36	36	50*	
			40			10	20	36	36	50*	
			50				15	36	36	50*	
			63					36	36	50*	
			80						36	50*	
			100							50*	
			125							50*	

Tmax T3 - S 800 N @400/415 V

			E.		T3						
			A.		N, S						
			Release		TM						
			Iu [A]		250						
L.	Char.	Icu [kA]	In [A]		63	80	100	125	160	200	250
S 800 N	B, C, D	36	10	8	10	20	25	36	36	36	
			13	7.5	10	15	25	36	36	36	
			16	7.5	10	15	25	36	36	36	
			20	7.5	10	15	25	36	36	36	
			25	6	10	15	20	36	36	36	
			32		7.5	10	20	36	36	36	
			40			10	20	36	36	36	
			50				15	36	36	36	
			63					36	36	36	
			80						36	36	
			100							36	
			125							36	

MCBs internal resistance, power loss and max. permissible earth-fault loop impedance

Internal resistance and power loss of the miniature circuit-breakers

Internal resistance per pole in mΩ, power loss per pole in W

Type	Rated current I_n A	Device series B, C, D ①		K		Z	
		mΩ	W	mΩ	W	mΩ	W
S 200 and S 200 M	0.5	5500	1.4	6340	1.6	10100	2.5
	1	1440	1.4	1550	1.6	2270	2.3
	1.6	630	1.6	695	1.8	1100	2.8
	2	460	1.8	460	1.9	619	2.5
	3	150	1.3	165	1.5	202	1.8
	4	110	1.8	120	2.0	149	2.4
	6	55	2.0	52	1.9	104	3.7
	8	15	1.0	38	2.5	53.9	3.45
	10	13.3	1.3	12.6	1.26	17.5	1.7
	13	13.3	2.3	12.6	1.26	–	–
	16	7.0	1.8	7.7	2.0	10.9	2.8
	20	6.25	2.5	6.7	2.7	6.0	2.4
	25	5.0	3.2	4.6	2.9	4.1	2.6
	32	3.6	3.7	3.5	3.6	2.8	2.9
	40	3.0	4.8	2.8	4.5	2.5	4.1
50	1.3	3.25	1.25	2.9	1.8	4.4	
63	1.2	4.8	0.7	5.2	1.3	5.2	

① Current intensities 0.5 – 4 apply exclusively to C-type trip characteristics.

Maximum permissible earth-fault loop impedance Z_S at $U_0 = 230 V\sim$ ② to ensure compliance with the operation conditions pursuant to IEC 60364-4. Operating time < 0.4 s; at 400 V~ < 0.2 s and at > 400 V~ < 0.1 s The instantaneous release of the MCB ensures an operating time of ≤ 0.1 s (TN system).

Determined according to DIN VDE 0100-520 sheet 2:2002-11(source impedance = 300 mΩ, c = 0.95 and conductor temperature 70 °C = factor 0.8). The internal resistance of the MCB is already included.

S 200 and S 200 M

Rated current I_n A	B	C	D	K	Z
	max. Z_S Ω	max. Z_S Ω	max. Z_S Ω	max. Z_S Ω	max. Z_S Ω
0.5	–	46	33.0	33.0	153.3
1	–	23	16.5	16.5	76.7
1.6	–	14.4	10.3	10.3	47.9
2	–	11.5	8.2	8.2	38.3
3	–	7.7	5.5	5.5	25.6
4	–	5.8	4.1	4.1	19.2
6	7.7	3.8	2.7	2.7	12.8
8	–	2.8	2.1	2.1	9.5
10	4.6	2.2	1.6	1.6	7.7
13	3.5	1.7	1.2	1.2	–
16	2.9	1.4	1.0	1.0	4.8
20	2.3	1.2	0.8	0.8	3.8
25	1.8	0.9	0.7	0.7	3.1
32	1.4	0.7	0.5	0.5	2.4
40	1.1	0.6	0.4	0.4	1.9
50	0.9	0.5	0.3	0.3	1.5
63	0.7	0.4	0.3	0.3	1.2

② U_0 = rated voltage against earthed conductor; for $U_0 = 240 V\sim$ is $Z_S \cdot 1.04$; for $U_0 = 127 V\sim$ is $Z_S \cdot 0.55$

Take into account the voltage drop:

e.g. in the case of a 1.5 mm² conductor, protected by a B 16 circuit-breaker, the maximum cable length is 82 m.

If the voltage drop is below 3%, this would result in a maximum cable length (2-strand) of 17 m.

For more details on this topic, get your own copy of the technical information leaflet "Maximum cable lengths".

Maximum cable lengths in the case of different voltages and cross sections on request.

**MCBs internal resistance, power loss
and max. permissible earth-fault loop impedance**

Internal resistance and power loss of the miniature circuit-breakers

Internal resistance per pole in mΩ, power loss per pole in W

Type	Rated current I_n A	Device series B, C, D ①		K		Z	
		mΩ	W	mΩ	W	mΩ	W
S 200 P	0.2	–	–	42500	1.7	–	–
	0.3	–	–	20000	1.8	–	–
	0.5	5500	1.4	6340	1.6	10100	2.5
	0.75	–	–	2500	1.4	–	–
	1	1440	1.4	1400	1.4	2270	2.3
	1.6	630	1.6	625	1.6	1100	2.8
	2	460	1.8	460	1.8	619	2.5
	3	211	1.9	211	1.9	211	1.9
	4	150	2.4	163	2.6	163	2.6
	6	61	2.2	67	2.4	104	3.7
	8	45	2.9	45	2.9	55	3.5
	10	14	1.4	19	1.9	21	2.1
	13	13.3	2.3	–	–	–	–
	16	9.7	2.5	8.2	2.1	10.9	2.8
	20	7.3	2.9	7.3	2.9	7.3	2.9
	25	5.6	3.5	5.6	3.5	5.6	3.5
	32	4.1	4.2	4.1	4.2	4.1	4.2
	40	4.0	6.4	4.0	6.4	4.0	6.4
	50	1.2	3.0	1.2	3.0	1.8	4.4
	63	1.4	5.6	1.3	5.2	1.3	5.2

① Current intensities 0.5 – 4 apply exclusively to C-type trip characteristics.

**Maximum permissible earth-fault loop impedance Z_S at $U_0 = 230 V\sim$ ②
to ensure compliance with the operation conditions pursuant to IEC 60364-4.
Operating time < 0.4 s; at 400 V~ < 0.2 s and at > 400 V~ < 0.1 s
The instantaneous release of the MCB ensures an operating time of ≤ 0.1 s (TN system).**

Determined according to DIN VDE 0100-520 sheet 2:2002-11(source impedance = 300 mΩ, c = 0.95 and conductor temperature 70 °C = factor 0.8). The internal resistance of the MCB is already included.

S 200 P

Rated current I_n A	B max. Z_S Ω	C max. Z_S Ω	D max. Z_S Ω	K max. Z_S Ω	Z max. Z_S Ω
0.2	–	–	–	40	–
0.3	–	–	–	34.8	–
0.5	–	46	27.4	26.5	143
0.75	–	–	–	19.4	–
1	–	23	15	15	74.4
1.6	–	14.4	9.6	9.6	47.9
2	–	11.5	7.8	7.8	38.3
3	–	7.7	11.8	5.3	25.3
4	–	5.8	8.8	4.1	19.1
6	7.6	3.8	5.9	2.7	12.7
8	–	2.8	5.7	2.0	9.5
10	4.6	2.3	3.5	1.6	7.6
13	3.5	1.7	2.7	–	–
16	2.9	1.4	2.2	1.0	4.7
20	2.3	1.1	1.7	0.8	3.8
25	1.8	0.9	1.4	0.6	3.0
32	1.4	0.7	1.1	0.5	2.4
40	1.1	0.6	0.9	0.4	1.9
50	0.9	0.5	0.7	0.3	1.5
63	0.7	0.4	0.6	0.25	1.1

② U_0 = rated voltage against earthed conductor; for $U_0 = 240 V\sim$ is $Z_S \cdot 1.04$; for $U_0 = 127 V\sim$ is $Z_S \cdot 0.55$

Take into account the voltage drop (see the previous page)

Derating of load capability of MCBs

Derating of MCBs load capability takes in consideration 3 factors:

- ambient temperature
- continuity (duration) of the load
- influence of adjacent devices

The 3 rules to obtain the effective value of I_n are the following:

1. Deviating ambient temperature:

The rated value of the current of a miniature circuit-breaker refers to a temperature of 20 °C for circuit-breakers with characteristics K and Z and 30 °C for characteristics B, C and D.

The following tables contain the derating of load capability of S 200/M/P MCBs* with temperature from -40 °C to 70 °C for the curves B, C, D and K, Z.

Max. operating current depending on the ambient temperature of a circuit-breaker in load circuit of characteristics type B, C and D

B, C and D In (A)	Ambient temperature T (°C)											
	- 40	- 30	- 20	- 10	0	10	20	30	40	50	60	70
0.5	0.67	0.65	0.62	0.60	0.58	0.55	0.53	0.50	0.47	0.44	0.41	0.37
1.0	1.33	1.29	1.25	1.20	1.15	1.11	1.05	1.00	0.94	0.88	0.82	0.75
1.6	2.13	2.07	2.00	1.92	1.85	1.77	1.69	1.60	1.51	1.41	1.31	1.19
2.0	2.67	2.58	2.49	2.40	2.31	2.21	2.11	2.00	1.89	1.76	1.63	1.49
3.0	4.0	3.9	3.7	3.6	3.5	3.3	3.2	3.0	2.8	2.6	2.4	2.2
4.0	5.3	5.2	5.0	4.8	4.6	4.4	4.2	4.0	3.8	3.5	3.3	3.0
6.0	8.0	7.7	7.5	7.2	6.9	6.6	6.3	6.0	5.7	5.3	4.9	4.5
8.0	10.7	10.3	10.0	9.6	9.2	8.8	8.4	8.0	7.5	7.1	6.5	6.0
10.0	13.3	12.9	12.5	12.0	11.5	11.1	10.5	10.0	9.4	8.8	8.2	7.5
13.0	17.3	16.8	16.2	15.6	15.0	14.4	13.7	13.0	12.3	11.5	10.6	9.7
16.0	21.3	20.7	20.0	19.2	18.5	17.7	16.9	16.0	15.1	14.1	13.1	11.9
20.0	26.7	25.8	24.9	24.0	23.1	22.1	21.1	20.0	18.9	17.6	16.3	14.9
25.0	33.3	32.3	31.2	30.0	28.9	27.6	26.4	25.0	23.6	22.0	20.4	18.6
32.0	42.7	41.3	39.9	38.5	37.0	35.4	33.7	32.0	30.2	28.2	26.1	23.9
40.0	53.3	51.6	49.9	48.1	46.2	44.2	42.2	40.0	37.7	35.3	32.7	29.8
50.0	66.7	64.5	62.4	60.1	57.7	55.3	52.7	50.0	47.1	44.1	40.8	37.3
63.0	84.0	81.3	78.6	75.7	72.7	69.6	66.4	63.0	59.4	55.6	51.4	47.0
80.0	112.6	107.2	102.1	97.2	92.6	88.2	84.0	80.0	76.0	72.2	68.6	65.2
100.0	140.7	134.0	127.6	121.6	115.8	110.3	105.0	100.0	95.0	90.3	85.7	81.5
125.0	175.9	167.5	159.5	151.9	144.7	137.8	131.3	125.0	118.8	112.8	107.2	101.8

Max. operating current depending on the ambient temperature of a circuit-breaker in load circuit of characteristics type K and Z

K and Z In (A)	Ambient temperature T (°C)											
	- 40	- 30	- 20	- 10	0	10	20	30	40	50	60	70
0.5	0.66	0.64	0.61	0.59	0.56	0.53	0.50	0.47	0.43	0.40	0.35	0.31
1.0	1.32	1.27	1.22	1.17	1.12	1.06	1.00	0.94	0.87	0.79	0.71	0.61
1.6	2.12	2.04	1.96	1.88	1.79	1.70	1.60	1.50	1.39	1.26	1.13	0.98
2.0	2.65	2.55	2.45	2.35	2.24	2.12	2.00	1.87	1.73	1.58	1.41	1.22
3.0	4.0	3.8	3.7	3.5	3.4	3.2	3.0	2.8	2.6	2.4	2.1	1.8
4.0	5.3	5.1	4.9	4.7	4.5	4.2	4.0	3.7	3.5	3.2	2.8	2.4
6.0	7.9	7.6	7.3	7.0	6.7	6.4	6.0	5.6	5.2	4.7	4.2	3.7
8.0	10.8	10.2	9.8	9.4	8.9	8.5	8.0	7.5	6.9	6.3	5.7	4.9
10.0	13.2	12.7	12.2	11.7	11.2	10.6	10.0	9.4	8.7	7.9	7.1	6.1
13.0	17.2	16.6	15.9	15.2	14.5	13.8	13.0	12.2	11.3	10.3	9.2	8.0
16.0	21.2	20.4	19.6	18.8	17.9	17.0	16.0	15.0	13.9	12.6	11.3	9.8
20.0	26.5	25.5	24.5	23.5	22.4	21.2	20.0	18.7	17.3	15.8	14.1	12.2
25.0	33.1	31.9	30.6	29.3	28.0	26.5	25.0	23.4	21.7	19.8	17.7	15.3
32.0	42.3	40.8	39.2	37.5	35.8	33.9	32.0	29.9	27.7	25.3	22.6	19.6
40.0	52.9	51.0	49.0	46.9	44.7	42.4	40.0	37.4	34.6	31.6	28.3	24.5
50.0	66.1	63.7	61.2	58.6	55.9	53.0	50.0	46.8	43.3	39.5	35.4	30.6
63.0	83.3	80.3	77.2	73.9	70.4	66.8	63.0	58.9	54.6	49.8	44.5	38.6

* the same tables contain derating of FS 201 and DS 200 RCBOs with temperature from -25 °C to 55 °C for the curves B, C and K.

Performances at different ambient temperatures, altitudes and frequencies

2. Multiply the rated current (equivalent) referring to the new temperature by another factor 0.9 only for loads that last for more than an hour.

3. Multiply the rated current (equivalent) referring to the new temperature by another factor only in case of presence of several devices installed alongside each other; see table.

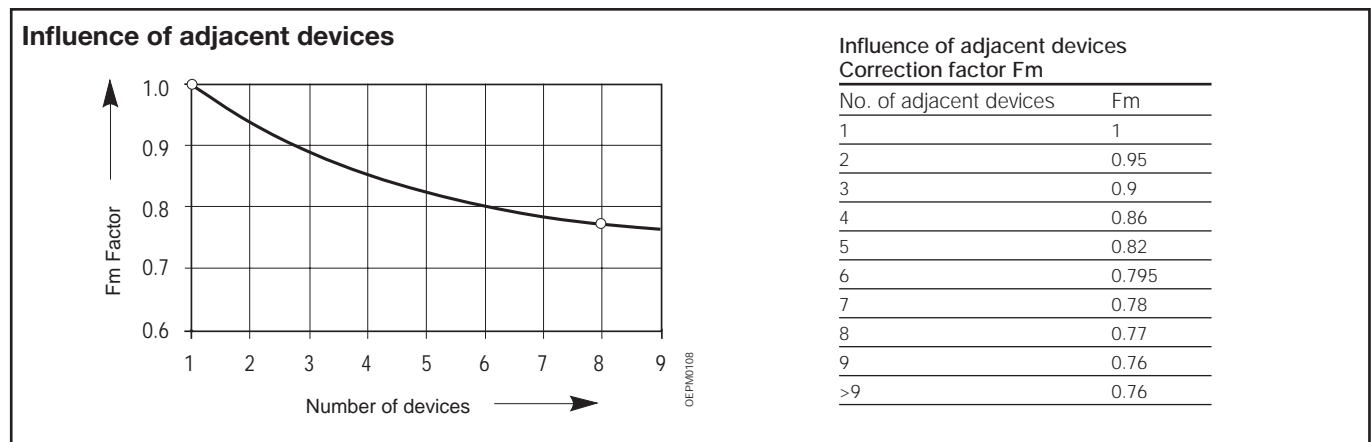

Example: S 202 C 16 with T=35 °C

Type of use	Values to use	Formula	Calculation	Result
Load less than an hour	In (amb. t°) -see tables-			In=15.43 A
Load more than an hour	In (amb. t°) -see tables-, 0.9	In (amb. t°)x0.9	15.43x0.9	In=13.9 A
Load over an hour with 8 adj. devices	In (amb. t°) -see tables-, 0.9, Fm (0.77)	In (amb. t°)x0.9x0.77	15.43x0.9x0.77	In=10.7 A

Use of S 200/S 200 M/S 200 P miniature circuit-breakers in direct current circuits 72 VDC/125 VDC

In DC systems up to 72 VDC or, as the case may be, series connection up to 125 VDC, customary S 200/S 200 M series MCBs can be used. Polarity does not need to be taken into consideration, the outgoing circuit may be implemented from above or below the device.
For higher direct voltage up to 440 VDC devices of the S 280 UC series must be used.

Example for max. permissible voltages between conductors depending on the number of poles and type of connection.

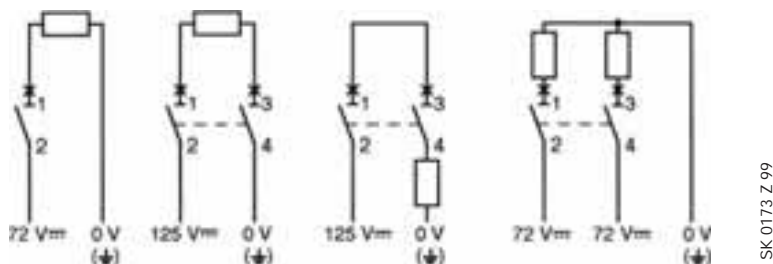

Examples for different voltages between a conductor and earth where voltages between conductors are identical:

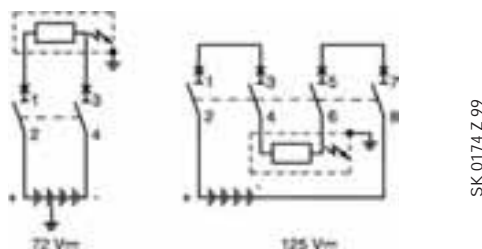

Performance in altitude of MCBs

Up to the height of 2000 m, MCBs do not undergo any alterations in their rated performances. Over this height the properties of the atmosphere change in terms of composition, dielectric capacity, cooling capacity and pressure, therefore the performances of the MCBs undergo derating, which can basically be measured in terms of variations in significant parameters, such as the maximum operating voltage and the rated current.

S 200/M/P

Altitude[m]	2000	3000	4000
Rated service voltage Ue[V]	440	380	380
Rated current In	In	0.96xIn	0.93xIn

Variation of tripping thresholds of MCBs according to network frequency

The circuit-breakers are calibrated for a current with a frequency range between 50 and 60 Hz.

For other frequency values, the electro-magnetic tripping current varies according to the multiplication factor H.

	D.C.	100 Hz	200Hz	400Hz
H	1.5	1.1	1.2	1.5

For the thermal trip, on the other hand, there is no variation because it is independent of the network frequency.

Example:

S 202 C10 supplied at 50-60 Hz, the electro-magnetic tripping current is: $50 A \leq I_m \leq 100 A$;
S 202 C10 supplied at 400 Hz, the electro-magnetic tripping current is: $75 A \leq I_m \leq 150 A$.

Lighting circuit protection

Selection of circuit-breakers for the protection of lighting circuit and calculation of their rated current

To select the correct circuit-breaker for use in the protection of lighting circuits you need to know the type of load based on which you will work out the breaker's rated current. The protection circuit utilization current can be calculated simply starting with the rated power and the lighting voltage, or it may be supplied directly by the device manufacturer.

Considering the utilization current, it is important to select the version of the breaker with a rated current just above the value calculated, defining the cable cross-section accordingly.

The tables below show the rated current values of the circuit-breakers to be used according to the type and power of the device connected.

Table 1 High pressure discharge lamps

230 V and 400 VAC three-phase with or without power factor correcting capacitors, star or delta connection

Mercury vapour fluorescent lamp	Pw [W]	<700	<1000	<2000
	I [A]	6	10	16
Mercury vapour metal halogen lamp	Pw [W]	<375	<1000	<2000
	I [A]	6	10	16
High pressure sodium discharge lamp	Pw [W]	<400		<1000
	I [A]	6		16

Table 2 Fluorescent lamps

230 VAC single-phase/three-phase with neutral (400 V), with star connection.

The tables indicate the rated current of the circuit-breakers according to the lamp power and type of power supply.

Example of calculation

- Starter dissipated power: 25% of lamp power
- Reference temperature: 30 and 40 °C according to circuit-breaker
- Power factor: lamp without capacitors $\cos\phi=0.6$
lamp with capacitors $\cos\phi=0.86$

Method of calculation

- $IB = (PL * n^{\circ}L * KST * KC) / (Un * \cos\phi)$ where:
 - Un = rated voltage 230 V
 - $\cos\phi$ = power factor
 - PL = lamp power
 - $n^{\circ}L$ = number of lamps per phase
 - KST = 1.25
 - KC = 1 for star connection and 1.732 for delta connection

11

Type of lamp	Tube diss. pwr. [W]	Number of lamps per phase													
Single without capacitors	18	4	9	14	29	49	78	98	122	157	196	245	309	392	490
	36	2	4	7	14	24	39	49	61	78	98	122	154	196	245
	58	1	3	4	9	15	24	30	38	48	60	76	95	121	152
Single with capacitors	18	7	14	21	42	70	112	140	175	225	281	351	443	562	703
	36	3	7	10	21	35	56	70	87	112	140	175	221	281	351
	58	2	4	6	13	21	34	43	54	69	87	109	137	174	218
Double with capacitors	2x18=36	3	7	10	21	35	56	70	87	112	140	175	221	281	351
	2x36=72	1	3	5	10	17	28	35	43	56	70	87	110	140	175
	2x58=116	1	2	3	6	10	17	21	27	34	43	54	68	87	109
In [A] - 2P and 4P circuit-breakers		1	2	3	6	10	16	20	25	32	40	50	63	80	100

Fluorescent lamps. 230 VAC three-phase – Delta connection

Type of lamp	Tube diss. pwr. [W]	Number of lamps per phase													
Single without capacitors	18	2	5	8	16	28	45	56	70	90	113	141	178	226	283
	36	1	2	4	8	14	22	28	35	45	56	70	89	113	141
	58	0	1	2	5	8	14	17	21	28	35	43	55	70	87
Single with capacitors	18	4	8	12	24	40	64	81	101	127	162	203	255	324	406
	36	2	4	6	12	20	32	40	50	64	81	101	127	162	203
	58	1	2	3	7	12	20	25	31	40	50	63	79	100	126
Double with capacitors	2x18=36	2	4	6	12	20	32	40	50	64	81	101	127	162	203
	2x36=72	1	2	3	6	10	16	20	25	32	40	50	63	81	101
	2x58=116	0	1	1	3	6	10	12	15	20	25	31	39	50	63
In [A] - 3P circuit-break.		1	2	3	6	10	16	20	25	32	40	50	63	80	100

Transformer protection

Insertion current

When the LV/LV transformers are powered up, very strong currents occur, which must be considered when selecting the protective device. The peak value of the first current wave often reaches a value between 10 and 15 times the transformer's effective rated current.

For power ratings below 50 kVA, it may reach between 20 and 25 times the rated current. This transient current decreases very rapidly with a time constant T varying from several ms to 10, 20 ms.

Main protection on the primary side

The tables below are the result of a set of tests on co-ordination between circuit-breakers and BT/BT transformers. The transformers used in the tests are normalized. The table, referring to a primary supply voltage of 230 or 400 V and to single-phase and three-phase transformers, indicate which circuit-breaker should be used according to the transformer power rating.

The transformers considered have the primary winding outside the secondary winding.

The circuit-breakers suggested allow:

- transformer protection in the event of maximum short-circuit;
- prevention of unwanted tripping when the primary winding is powered up using
 1. modular circuit-breakers with a high magnetic threshold, curve D or K
 2. circuit-breakers with magnetic only releaser;
- guaranteed circuit-breaker electrical life.

Protection on the secondary side

Due to the transformer's high insertion current, the circuit-breaker on the primary winding may not guarantee thermal protection for the transformer and its feeder line on the primary side.

This is typical of modular circuit-breakers which must have a higher rated current than the transformers. In such cases, in the event of a single-phase short-circuit at the transformer's primary terminals (minimum I_{cc} at end of line), check that the circuit-breaker's magnetic releaser is tripped. In the normal application in distribution panels, this condition is always satisfied provided that the length of the feeder lines is reduced.

The transformer can be provided with thermal protection by installing a circuit-breaker with a rated current less than or equal to that of the transformer secondary winding immediately downstream of the LV/LV transformer.

In lighting systems protection against overloads is not necessary if the number of light points is clearly defined (no overloads).

Moreover, the Standard in force for these systems recommends the omission of protection against overloads in circuits in which unwanted tripping may prove hazardous, e.g.: circuits which supply fire-fighting equipment.

Single-phase transformer (primary voltage 230 V)-1P and 1P+N MCBs

Pn [kVA]	In [A]	ucc (%)	Circuit-breaker on primary side (1) and (2)
0.1	0.4	13	S 2* D1 o K1
0.16	0.7	10.5	S 2* D2 o K2
0.25	1.1	9.5	S 2* D3 o K3
0.4	1.7	7.5	S 2* D4 o K4
0.63	2.7	7	S 2* D6 o K6
1	4.2	5.2	S 2* D10 o K10
1.6	6.8	4	S 2* D16 o K16
2	8.4	2.9	S 2* D16 o K16
2.5	10.5	3	S 2* D20 o K20
4	16.9	2.1	S 2* D40 o K40
5	21.1	4.5	S 2* D50 o K50
6.3	27	4.5	S 2* D63 o K63
8	34	5	S 290 D80
10	42	5.5	S 290 D100
12.5	53	5.5	S 290 D100

Single-phase transformer (primary voltage 400 V)-2P MCBs

Pn [kVA]	In [A]	ucc (%)	Circuit-breaker on primary side (1) and (2)
1	2.44	8	S 2* D6 o K6
1.6	3.9	8	S 2* D10 o K10
2.5	6.1	3	S 2* D16 o K16
4	9.8	2.1	S 2* D20 o K20
5	12.2	4.5	S 2* D32 o K32
6.3	15.4	4.5	S 2* D40 o K40
8	19.5	5	S 2* D50 o K50
10	24	5	S 2* D63 o K63
12.5	30	5	S 2* D63 o K63
16	39	5	S 290 D80
20	49	5	S 290 D100

Three-phase transformer (primary voltage 400 V)-3P, 3P+N and 4P MCBs

Pn [kVA]	In [A]	ucc (%)	Circuit-breaker on primary side (1) and (2)
5	7	4.5	S 2* D20 o K20
6.3	8.8	4.5	S 2* D20 o K20
8	11.6	4.5	S 2* D32 o K32
10	14	5.5	S 2* D32 o K32
12.5	17.6	5.5	S 2* D40 o K40
16	23	5.5	S 2* D63 o K63
20	28	5.5	S 2* D63 o K63
25	35	5.5	S 290 D80
31.5	44	5	S 290 D80
40	56	5	S 290 D80
50	70	4.5	S 290 D100

S 2*.. = S 200, S 200 M, S 200 P

(1) With modular or magnetic only circuit-breakers, without thermal adjustment, thermal protection is required for the transformer's secondary winding.

(2) Breaking capacity selected according to estimated Icc at the point where the breaker is installed.

Double tampoprinting of S 200 P

The breaking capacity

For the modular circuit-breakers realized according to IEC/EN 60898 standard, the breaking capacity is expressed by the I_{cn} quantity, indicated in Ampere, contained within a rectangle on the front side of the device. The max value of rated short-circuit capacity (I_{cn}) considered by this standard is 25000 A.

Always according to IEC/EN 60898 standard, the ratio between the service short-circuit capacity (I_{cs}) and the rated short-circuit capacity (I_{cn}) – K factor – shall have to be conforming to the enclosed table.

I_{cn}	K
< 6000 A	1
> 6000 A	
< 10000 A	0.75 ^(*)
>10000 A	0.5 ^(**)

(*) I_{cs} minimum value: 6000 A
(**) I_{cs} minimum value: 7500 A

Limiting class

The Manufacturer of the circuit-breaker has the right to declare the energy limiting class of the device. According to IEC/EN 60898 standard, the Manufacturer classifies the circuit-breaker with a limiting class which ranges from 1 to 3 according to the I^2t values let through by the circuit-breaker for rated current up to 16 A and rated currents exceeding 16 A up to 32 A included, according to the table below.

Short-circuit rated capacity (A)	Limited energy classes				
	1		2		3
	I^2t max (A ² s)		I^2t max (A ² s)		I^2t max (A ² s)
	B-C Type		B Type	C Type	B Type C Type
3000	No		31000	37000	15000 18000
4500	limits		60000	75000	25000 30000
6000	are		100000	120000	35000 42000
10000	specified		240000	290000	70000 84000

Short-circuit rated capacity (A)	Limited energy classes				
	1		2		3
	I^2t max (A ² s)		I^2t max (A ² s)		I^2t max (A ² s)
	B-C Type		B Type	C Type	B Type C Type
3000	No		40000	50000	18000 22000
4500	limits		80000	100000	32000 39000
6000	are		130000	160000	45000 55000
10000	specified		310000	370000	90000 110000

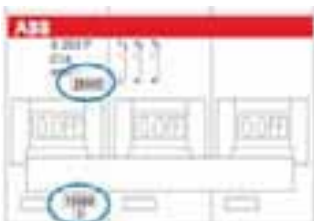

For instance, a circuit-breaker with rated current 16 A, B characteristic, with short-circuit rated capacity equal to 6 kA belongs to class 3 if it lets through max 35000 A²s of specific energy. The limiting class value (1, 2 or 3) is indicated on the front side of the device, within a square, in addition to the breaking capacity.

As regards the miniature circuit-breakers S200P series, two different breaking capacities are indicated on the front side of the device, contained in a rectangle.

The breaking capacity indicated above the operating toggle is the one of the device, according to IEC/EN 60898 standard, the breaking capacity indicated under the lever is regarding the limiting class which, according to the standard, can be expressed only for values up to 10000 A.

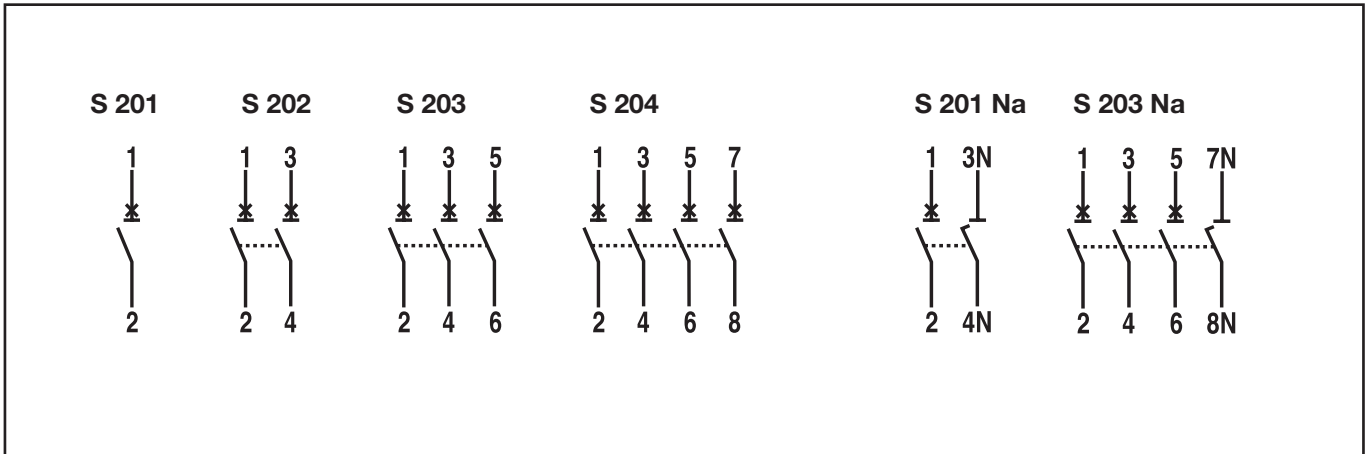



RCCBs



RCD-blocks



RCBOs

Functions and classification criteria for RCDs

A residual current operated circuit-breaker is an amperometric protection device which is tripped when the system leaks a significant current to earth.

This device continuously calculates the vector sum of the single-phase or three-phase system line currents and while the sum is equal to zero allows electricity to be supplied. This supply is rapidly interrupted if the sum exceeds a value preset according to the sensitivity of the device.

Residual current operated circuit-breakers can be classed according to four parameters:

- type of construction
- detectable wave form
- tripping sensitivity
- tripping time.

Depending on the type of construction, RCDs may be classed as:

- RCBOs (magnetothermic with overcurrent protection)
- RCCBs (without overcurrent protection releaser incorporated)
- RCD blocks.

RCBOs combine, in a single device, the residual current function and the overcurrent protection function typical of MCBs. RCBOs are tripped by both current leakage to earth and overloads and short-circuits and they are self-protecting up to a maximum short-circuit current value indicated on the label.

RCCBs are only sensitive to current leakage to earth. They must be used in series with an MCB or fuse which protects them from the potentially damaging thermal and dynamic stresses of any overcurrents.

These devices are used in systems already equipped with MCBs which preferably limit the specific energy passing through, also acting as the main disconnecting switches upstream of any derived MCBs (e.g.: domestic consumer unit).

RCD blocks are residual current devices suitable for assembly with a standard MCB. IEC/EN 61009 app. G only allows assembly of RCBOs once on site, that is to say outside the factory, using adaptable RCD blocks and the appropriate MCBs. Any subsequent attempts to separate them must leave permanent visible damage. The residual current operated circuit-breaker obtained in this way maintains both the electrical characteristics of the MCB and those of the RCD block.

According to the wave form of the earth leakage currents they are sensitive to, the RCDs may be classed as:

- AC type (for alternating current only)
- A type (for alternating and/or pulsating current with DC components)
- B type (for alternating and/or pulsating current with DC components and continuous fault current).

AC type RCDs are suitable for all systems where users have sinusoidal earth current.

They are not sensitive to impulsive leakage currents up to a peak of 250 A (8/20 wave form) such as those which may occur due to overlapping voltage impulses on the mains (e.g.: insertion of fluorescent bulbs, X-ray equipment, data processing systems and SCR controls).

A type RCDs are not sensitive to impulsive currents up to a peak of 250 A (8/20 wave form).

They are particularly suitable for protecting systems in which the user equipment has electronic devices for rectifying the current or phase cutting adjustment of a physical quantity (speed temperature, light intensity, etc.) supplied directly by the mains without the insertion of transformers and insulated in class I (class II is, by definition, free of faults to earth). These devices may generate a pulsating fault current with DC components which the A type RCD can recognise.

B type RCDs are recommended for use with drives and inverters for supplying motors for pumps, lifts, textile machines, machine tools, etc., since they recognise a continuous fault current with a low level ripple.

Type AC and type A RCDs comply with IEC/EN 61008/61009, whilst type B RCDs are not yet covered by any reference Standard for the household and similar use. Type B is covered only by IEC/EN 60947-2 for low voltage switchgear and control gear and by IEC/EN 60755 for residual current operated protective devices.

According to tripping sensitivity ($I_{\Delta n}$ value), RCDs may be divided into the following categories:

- low-sensitivity ($I_{\Delta n} > 0.03$ A), not suitable for protection against direct contacts; co-ordinated with the earth system according to the formula $I_{\Delta n} < 50/R$, to provide protection against indirect contacts;
- high-sensitivity ($I_{\Delta n}$: 0.01...0.03 A), or “physiologically sensitivity” for protection against indirect contacts, with simultaneous additional protection against direct contacts.
- against fire (up to 500 mA) according to IEC/EN 60364

Residual current sensitivity and environment

Household and special environments



$$I_{\Delta n} \leq 30 \text{ mA}$$

High-sensitivity or physiologically sensitive RCDs

IEC/EN 60364 make the use of these devices mandatory in all bathrooms, showers and private and public swimming pools and environments in which plugs and sockets may be installed without insulating or low safety voltage transformers.

Laboratories, service industry and small industry



$$I_{\Delta n} \text{ from } 30 \text{ mA} \text{ to } 500 \text{ mA}$$

Low-sensitivity RCDs

Large service industry and industrial complex



$$I_{\Delta n} \text{ from } 500 \text{ mA} \text{ to } 1000 \text{ mA}$$

According to their tripping time, RCDs can be classed as:

- instantaneous or rapid or general
- type S selective, or - incorrectly - delayed.

Selective RCDs (RCBOs - RCCBs or RCD-blocks) have a delayed tripping action and are installed upstream of other rapid residual current operated circuit-breakers to guarantee selectivity and limit the power out only to the portion of the system affected by a fault.

The tripping time is not adjustable. It is set according to a predetermined time – current characteristic with an intrinsic delay for small currents, tending to disappear as the current grows.

IEC/EN 61008 and 61009 establish the tripping times relative to the type of RCD and the $I_{\Delta n}$.

Type AC	I_n [A]	I_{Δ} [A]	Tripping times (s)xcurrents			
			$1 \times I_{\Delta}$	$2 \times I_{\Delta}$	$5 \times I_{\Delta}$	500A
Generic	Any	Any	0.3	0.15	0.04	0.04
S (selective)	≥ 25	> 0.030	0.13-0.5	0.06-0.2	0.05-0.15	0.04-0.15

The indicated maximum tripping times are also valid for A type RCDs, but increasing the current values of factor 1.4 for RCDs with $I_{\Delta n} > 0.01$ A and of factor 2 for RCDs with $I_{\Delta n} \leq 0.01$ A.

The range of ABB RCDs also includes AP-R (anti-disturbance) devices which trip according to the limit times allowed by the Standards for instantaneous RCDs. This function is due to the slight tripping delay (approx. 10 ms) relative to the standard instantaneous ones.

The graph shows the comparison of the qualitative tripping curves for:

- a 30 mA instantaneous RCD
- a 30 mA AP-R instantaneous RCD
- a 100 mA selective RCD (type S)

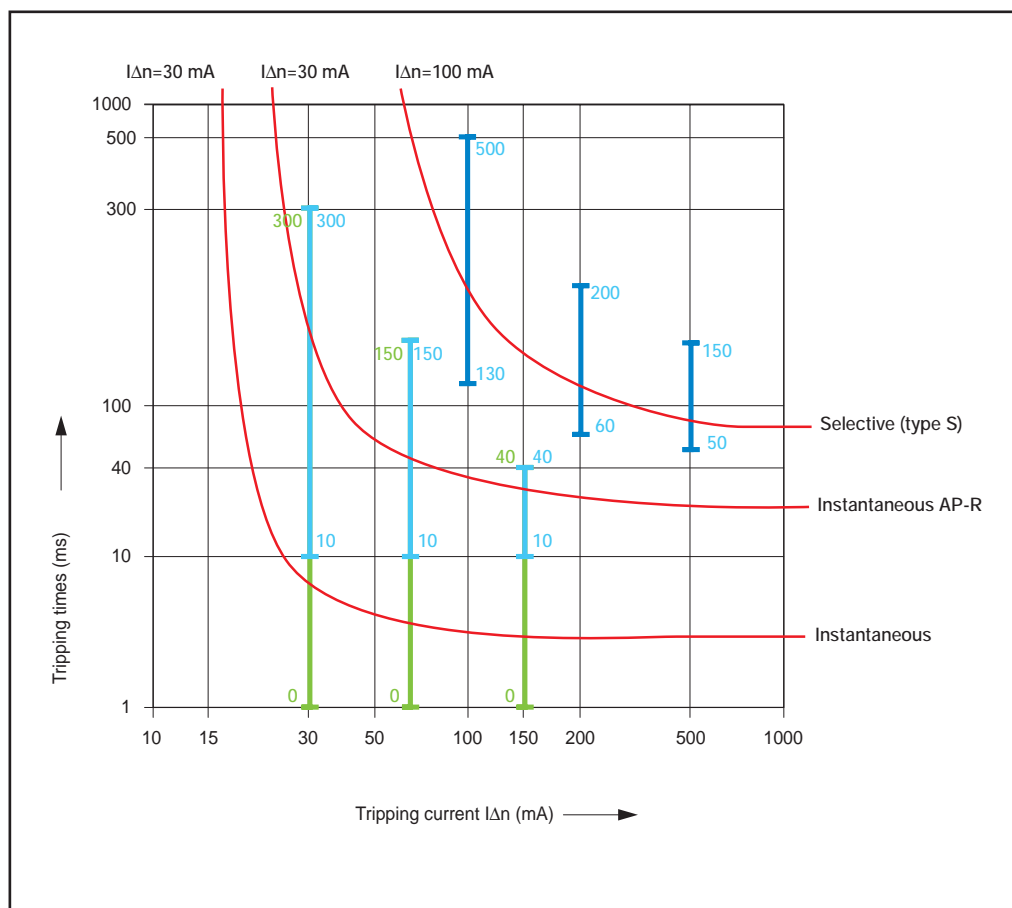

Note: this is a qualitative chart; it is referred only to industrial frequencies of 50-60 Hz.

For many years the manufacturers of electrical appliances and other electrical equipment have been using electronic components to improve the performance of their products, increase comfort and save energy.

Loads such as washing machines with variations in spin speed, variable-speed tools, thermostats and dimmers operate at currents with varying wave shapes (pulsating currents with DC components, inverted currents, levelled currents).

There are three different types of current (fig. A).

Figure A

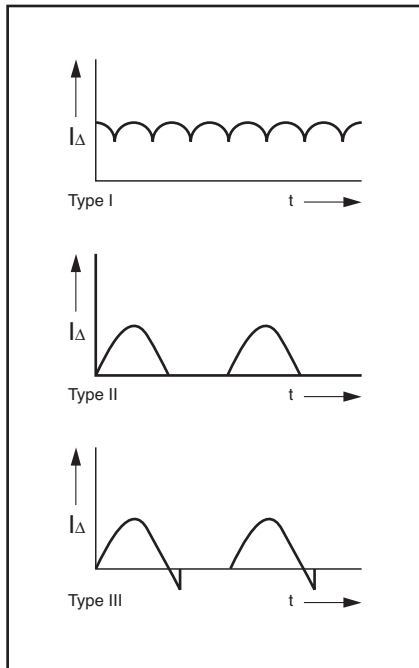

Type I Inverted current with DC components, with value continuously greater than zero, caused by:

- three-phase current
- median point and three-phase current
- jumper connection
- unidirectional rectification with inductive and capacitive levelling
- Villard type voltage doubling.

Type II Pulsating current with DC components sometimes with zero value, caused by ohmic load with:

- unidirectional rectification without levelling
- single-phase jumper connection with or without levelling
- regulation of the symmetrical and asymmetrical phase operating angle (dimers, RPM meters).

Type III Pulsating current with DC components passing through zero caused by inductive loads with:

- unidirectional rectification without levelling
- single-phase jumper connection with or without levelling
- symmetrical and asymmetrical regulation of the phase operating angle (dimers, RPM meters).

If there is a fault current to earth after an insulation fault on live parts supplied with rectified current, the contact voltages are the same size as in alternating current.

Standard RCDs, which are designed to operate with alternating current at 50-60 Hz, are insensitive to fault currents with DC components.

Non-tripping of a RCD when there are fault currents with DC components may have two consequences:

- it is dangerous for people and equipment (electrocution or fire)
- it causes desensitivation of RCD due to excessive polarization of the transformer core that is no longer able to send the necessary power supply to the releaser (figure B - hysteresis cycle 1).

To avoid this problem, type A RCDs must be used. Thanks to the specific technology of the residual current transformer toroidal cores, the supply level is increased to a value sufficient to trigger the releaser or tripping mechanism (figure B - hysteresis cycle 2).

The sensitivity of the tripping mechanism is further increased by its connection to an electrical circuit sensitive to the wave shape of the current.

In this way the tripping of the RCD is assured for any unidirectional pulsating wave shape even in case of overlapping of a DC component up to 6 mA.

Figure B

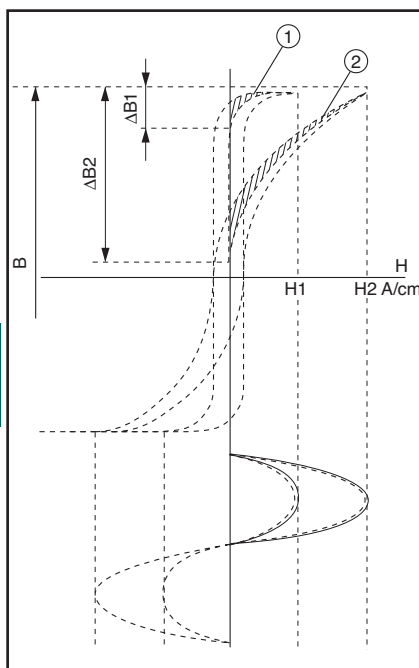

Coordination tables between Short Circuit Protection Devices (SCPD) and F 200 RCCBs

If you are using an RCCB you must verify that the Short Circuit Protection Device (SCPD) protects it from the effects of high current that arise under short-circuit conditions. The IEC/EN 61008 provides some tests to verify the behaviour of RCCB in short-circuit conditions. The tables below provide the maximum withstanding short-circuit current expressed in eff. kA for which the RCCBs are protected thanks to the coordination with the SCPD installed upstream or downstream. The tests are performed with SCPD with a rated current (thermal protection) less than or equal to the rated current of the associated RCCB.

F 202

	Single-phases 230-240V circuit		
	25A	40A	63A
S941N/S201L Na	4.5	4.5	
S951N/S201 Na	6	6	
S971N/S201M Na	10	10	
S202L	10	10	
S202	20	20	20
S202M	25	25	25
S202P	40	25	25
S292	25	25	25
S802S	50	50	50
Fuse 25gL	100		
Fuse 40gL	60	60	
Fuse 63gL	40	40	40
Fuse 80gL	25	25	25
Fuse 100gL	20	20	20
Fuse 125gL	10	10	10

F 202

	400-415V circuits with isolated neutral (IT) under double faults		
	25A	40A	63A
S941N	3	3	
S951N	3	3	
S971N	3	3	
S201L/S201L Na/S202L	4.5	4.5	
S201/S201 Na/S202	6	6	6
S201M/S201M Na/S202M	10	10	10
S201P/S201P Na/S202P	25	15	15
S291/S292	10	10	10
S801S/S802S	25	25	25

F 204

	Three-phases circuits with neutral (y/Δ) 230-240V/400-415V*		
	25A	40A	63A
S941N/S201L/S201LNa*	4.5	4.5	
S951N/S201/S201Na*	6	6	
S971N/S201M/S201MNa*	10	10	
S202L*	10	10	
S202*	20	20	20
S202M*	25	25	25
S202P*	40	25	25
S292*	25	25	25
S802S*	50	50	50
Fuse 25gL	100		
Fuse 40gL	60	60	
Fuse 63gL	40	40	40
Fuse 80gL	25	25	25
Fuse 100gL	20	20	20
Fuse 125gL	10	10	10

F 204

	Three-phases circuits with neutral (y/Δ) 230-240V/400-415V		
	25A	40A	63A
S203L/S204L	4.5	4.5	
S203/S204	6	6	6
S203M/S204M	10	10	10
S203P/S204P	25	15	15
S293/S294	10	10	10
S803S-S804S	25	25	25
Fuse 25gL	50		
Fuse 40gL	40	40	
Fuse 63gL	30	30	30
Fuse 80gL	25	25	25
Fuse 100gL	20	20	20
Fuse 125gL	10	10	10

F 204

	Three-phases circuits with neutral (y/Δ) 133-138V/230-240V		
	25A	40A	63A
S941N	10	10	
S951N	15	15	
S971N	20	20	
S203L/S204L	10	10	10
S203/S204	20	20	20
S203M/S204M	25	25	25
S203P/S204P	40	25	25
S293/S294	25	25	25
S803S-S804S	50	50	50
Fuse 25gL	100		
Fuse 40gL	60	60	
Fuse 63gL	40	40	40
Fuse 80gL	25	25	25
Fuse 100gL	20	20	20
Fuse 125gL	10	10	10

Selectivity

RCDs raise similar issue to those surrounding the installation of MCBs, and in particular the need to reduce to a minimum the parts of the system out of order in the event of a fault.

For RCBOs the problem of selectivity in the case of short-circuit currents may be handled with the same specific criteria as for MCBs.

However, for correct residual current protection, the more important aspects are linked to tripping times. Protection against contact voltages is only effective if the maximum times indicated on the safety curve are not exceeded.

If an electrical system has user devices with earth leakage currents which exceed the normal values (e.g.: presence of capacitor input filters inserted between the device phase and earth cables) or if the system consists of many user devices, it is good practice to install various RCDs, on the main branches, with an upstream main residual current or non-residual current device instead of a single main RCD.

Horizontal selectivity

The non-residual current main circuit-breaker provides “horizontal selectivity”, preventing an earth fault at any point on the circuit or small leakage from causing unwanted main circuit-breaker tripping, which would put the entire system out of order.

However, in this way, section k of the circuit between the main circuit-breaker and the RCDs remains without “active” protection. Using a main RCD to protect it would lead to problems with “vertical selectivity”, which require tripping of the various devices to be co-ordinated, so that service continuity and system safety are not compromised. In this case, selectivity may be amperometric (partial) or chronometric (total).

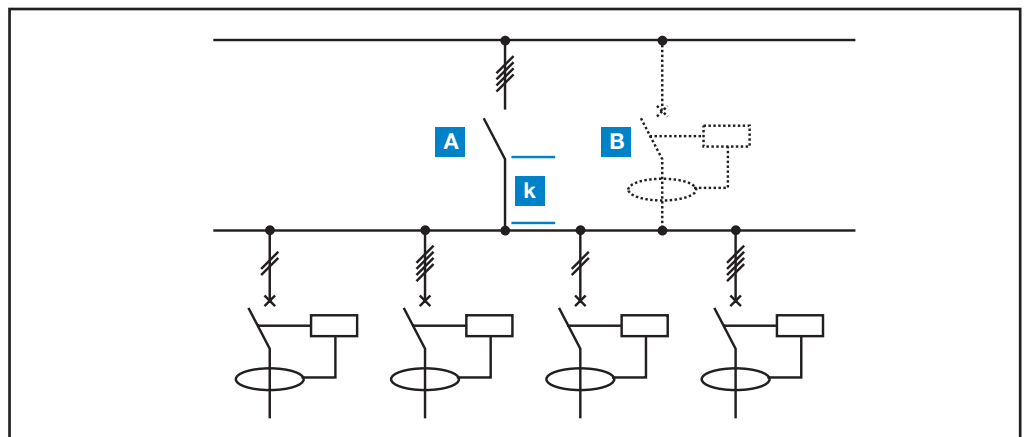

Vertical selectivity

Vertical selectivity may also be established for residual current tripping, bearing in mind that in working back from system peripheral branches to the main electrical panels the risk of unskilled persons coming into contact with dangerous parts is significantly reduced.

Amperometric (partial) selectivity

Selectivity may be created by placing low-sensitivity RCDs upstream and higher-sensitivity RCDs downstream.

An essential condition which must be satisfied in order to achieve selective co-ordination is that the $I_{\Delta 1}$ value of the breaker upstream (main breaker) is more than double the $I_{\Delta 2}$ value of the breaker downstream. The operative rule to obtain an amperometric (partial) selectivity is $I_{\Delta n}$ of the upstream breaker = 3 x $I_{\Delta n}$ of the downstream breaker (e. g.: F 204, A type, 300 mA upstream; F 202, A type, 100 mA downstream).

In this case, selectivity is partial and only the downstream breaker trips for earth fault currents $I_{\Delta 2} < I_{\Delta m} < 0.5 * I_{\Delta 1}$.

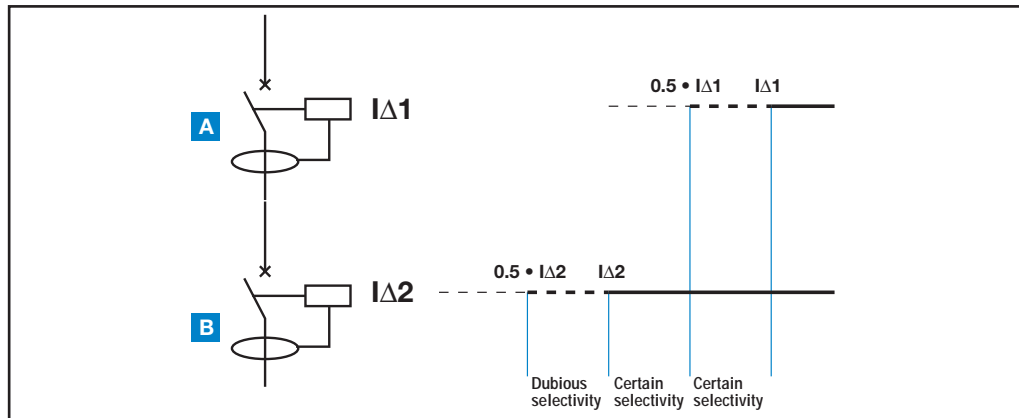

Chronometric (total) selectivity

To achieve total selectivity, delayed or selective RCDs must be installed.

The tripping times of the two devices connected in series must be co-ordinated so that the total interruption time t_2 of the downstream breaker is less than the upstream breaker's no-response limit time t_1 , for any current value. In this way, the downstream breaker completes its opening before the upstream one.

To completely guarantee total selectivity, the $I\Delta$ value of the upstream device must also be more than double that of the downstream device in accordance with IEC 64-8/563.3, comments. The operative rule to obtain an amperometric (partial) selectivity is $I\Delta_n$ of the upstream breaker = 3 x $I\Delta_n$ of the downstream breaker (e. g.: F 204, S type, 300 mA upstream; F 202, A type, 100 mA downstream).

For safety reasons, the delayed tripping times of the upstream breaker must always be below the safety curve.

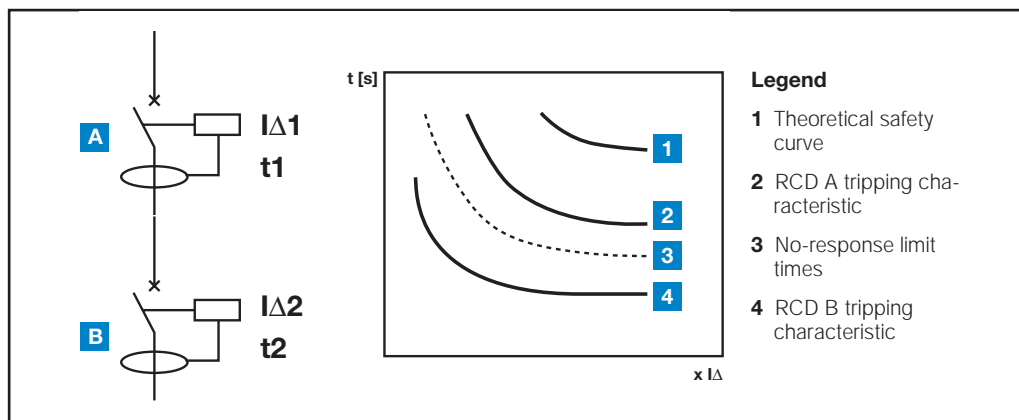

Table of RCD selectivity

Upstream $I\Delta_n$ [mA]		10	30	100	300	300	500	500	1000	1000
Downstream $I\Delta_n$ [mA]		inst	inst	inst	inst	S	inst	S	inst	S
10	inst		■	■	■	■	■	■	■	■
30	inst			■	■	■	■	■	■	■
100	inst				■	■	■	■	■	■
300	inst					■	■	■	■	■
300	S						■	■	■	■
500	inst								■	■
500	S									■
1000	inst									■
1000	S									■

inst=instantaneous S=selective ■=amperometric (partial) selectivity ■=chronometric (total) selectivity

Power loss of RCDs

RCCBs F200 series

Rated current In [A]	Power loss W [W]	
	2P	4P
16	1.5	-
25	2.0	4.8
40	4.8	8.4
63	7.2	13.2
80	8.8	33,3
100	15.2	44,4
125	-	28

RCD-Blocks DDA200 series

Rated current Ib [A]	Power loss W _{Ib} * [W]	
	2P	3P,4P
25	2.1	2.8
40	5.4	7.2
63	7.8	13.8

*The power loss W_{Ib} shown in the table refers to Ib. For use with circuit-breakers with lower rated current In the power loss W must be determined using the formula: $W = (I / Ib) \cdot W_{Ib}$

DDA for S290 series

Rated current Ib [A]	Rated residual current IΔn [A]	Power loss W [W]	
		2P	4P
100	0.03	6	6
100	0.03 - 1	5	5

RCBO FS201-DS200 series

Rated current In [A]	Power loss W [W]		
	1P+N	2P	3P,4P
1	1.8	-	-
2	1.8	-	-
4	1.8	-	-
6	2	4.1	6.2
10	2.1	2.9	4.4
13	3.7	5.2	7.7
16	4.5	4.5	6.6
20	4.8	6.4	9.3
25	6.3	8.5	12.4
32	8.8	10.9	15.7
40	9.9	15.0	21.6
50	-	11.4	18.4
63	-	17.4	28.2

RCBO DS9 series

Rated current In [A]	Power loss W [W]
	1P+N
6	2,5
10	2
16	3,3
20	3
25	4
32	5,7
40	5,16

Derating of load capability of RCBOs FS 201 and DS 200

For FS 201 and DS 200 see tables for S 200 MCBs in technical details MCBs, within the range of temperatures from -25 °C to +55 °C.

Performance in altitude of RCDs

Up to the height of 2000 m, ABB RCDs do not undergo any alterations in their rated performances. Over this height the properties of the atmosphere change in terms of composition, dielectric capacity, cooling capacity and pressure, therefore the performances of the RCDs undergo derating, which can basically be measured in terms of variations in significant parameters, such as the maximum operating voltage and the rated current.

F 200/DDA 200/FS 201/DS 200

Altitude [m]	2000	3000	4000
Rated service voltage Ue [V]	400	380	380
Rated current In	In	0.96xIn	0.93xIn

Emergency stop using DDA 200 AE series RCD blocks

The AE series RCD block combines the protection supplied by the RCBOs with a positive safety emergency stop function for remote tripping.

In the AE version, the DDA 200 AE series RCD blocks are available.

Operating principle (patented)

Two additional primary circuits powered with the same voltage and equipped with the same resistance have been added to the transformer; under normal conditions the same current would flow through, but since they are wound by the same number of coils in opposite directions they cancel each other out and do not produce any flow.

One of these two windings acts as the remote control circuit: the emergency stop is obtained by interrupting the current flow in this circuit.

The positive safety is therefore obvious: an accidental breakage in the circuit is equivalent to operating an emergency control button.

Advantages

Compared with the devices which are normally used in emergency circuits, DDA 200 AE blocks have the following advantages:

- positive safety
- no undesirable tripping if there is a temporary reduction or interruption of the mains voltage
- efficient immediate operating even after long off-service periods of the installation.

Use

Application of the DDA 200 AE blocks complies with the requirements of IEC/EN 60364-8. They are therefore suitable, for example, for escalators, lifts, hoists, electrically operated gates, machine tools, car washes and conveyor belts.

No more than one DDA 200 AE can be controlled using the same control circuit. Each DDA 200 AE requires a dedicated control circuit.

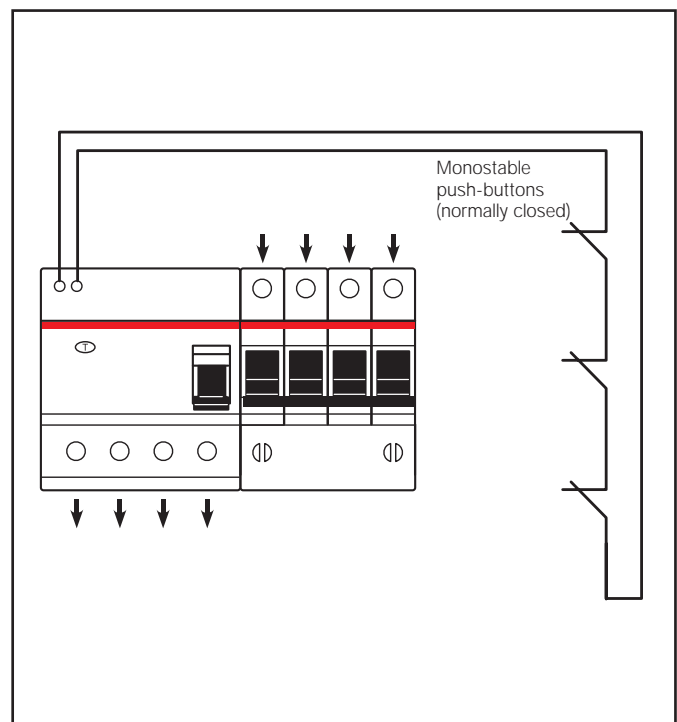
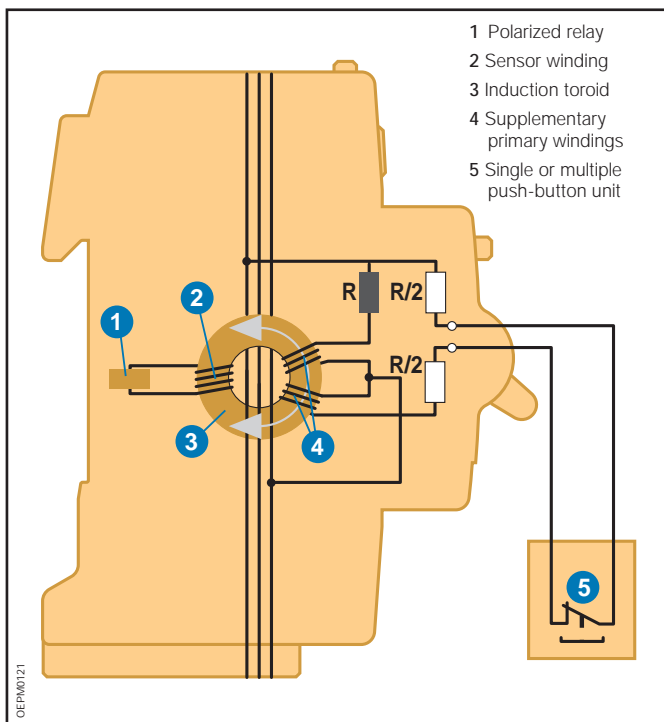

Unwanted tripping

In the event of disturbance in the mains, the RCDs normally present in the system are tripped, breaking the circuit even in the absence of a true earth fault.

Disturbances of this kind are most often caused by:

- operation overvoltages caused by inserting or removing loads (opening or closing protection of control devices, starting and stopping motors, switching fluorescent lighting systems on and off, etc.)
- overvoltages of atmospheric origin, caused by direct or indirect discharges on the electrical line.

Under these circumstances, breaker tripping is unwanted, since it does not satisfy the need to avoid the risks due to direct and indirect contacts. On the contrary, the sudden and unjustified interruption of the power supply may result in very serious problems.

AP-R RCDs

The ABB range of AP-R anti-disturbance residual current circuit-breakers and blocks was designed to overcome the problem of unwanted tripping due to overvoltages of atmospheric or operation origin.

The electronic circuit in these devices can distinguish between temporary leakage caused by disturbances on the mains and permanent leakage due to actual faults, only breaking the circuit in the latter case.

AP-R residual current circuit-breakers and blocks have a slight delay into the tripping time, but this does not compromise the safety limits set by the Standards in force (release time at $2 I_{\Delta n}=150$ ms).

Guaranteeing conventional residual current protection, their installation in the electrical circuit therefore allows any unwanted tripping to be avoided in domestic and industrial systems in which service continuity is essential.

For continuous service of priority circuits and simultaneous protection of user devices and systems from transient overvoltage peaks, combine RCCBs and AP-R blocks with overvoltage surge protective devices OVR.

To make protection more effective and widespread, it may be useful to create a cascade system extending over several levels, like the one illustrated below.

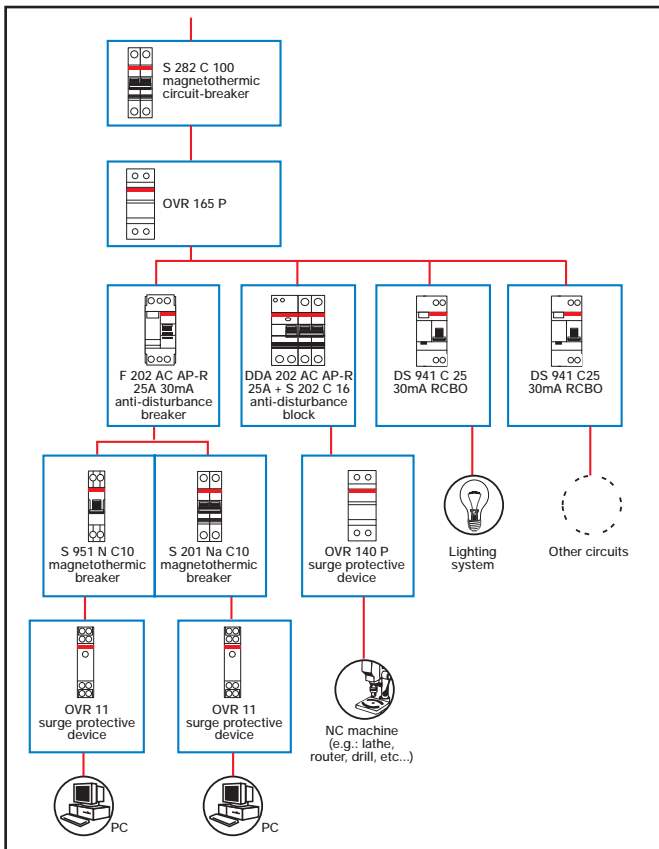

Provisions of the Standards

IEC/EN 61008 and IEC/EN 61009 check RCD resistance to operation overvoltages, envisaging the use of the $0.5 \mu\text{s}/100 \text{ kHz}$ ring wave. All RCDs must pass the test with a current peak value of 200 A.

For overvoltages of atmospheric origin, IEC 61008 and IEC 61009 establish the resistance to a $8/20 \mu\text{s}$ surge with 3000A peak current, but limit the provision to RCDs classed as selective. No test is required for other types of RCDs.

ABB AP-R anti-disturbance RCDs pass the general resistance test at $0.5 \mu\text{s}/100 \text{ kHz}$, also resisting the $8/20 \mu\text{s}$ surge with the same peak current of 3000 A prescribed for the selective RCDs.

Type B RCDs

In industrial electrical applications it is more and more common to use devices where in the event of an earth fault current unidirectional direct currents or currents with a minimum residual ripple which flow through the PE conductor can emerge. These devices can be for example inverters, medical equipment (e.g. x-ray equipment and CAT), or UPS.

Type A RCDs sensitive to pulsating currents (in addition to sinusoidal currents detected by RCDs of type AC as well) cannot detect and break these earth fault direct currents or currents with a minimum level residual ripple. In case there are electrical appliances which generate this type of currents in the event of an earth fault the use of RCDs of type AC or type A would not be appropriate.

In order to meet these new demands, type B RCDs have been designed (which are able to detect the same earth fault currents detected by type AC and type A RCDs).

This type of RCD (type B) is not mentioned in the reference standards for RCDs (IEC 61008-1 and IEC 61009-1). An international standard has been introduced in 2007 and it specifies additional requirements for B type RCDs.

This new standard, IEC 62423, can only be referred to together with IEC 61008-1 (for RCCBs) and IEC 61009-1 (for RCD-blocks and RCBOs), this means that B type RCDs have to be compliant to all the prescriptions of IEC 61008/9.

As already said, type B RCDs are not only sensitive to alternating and pulsating earth fault currents with DC components at a frequency of 50/60 Hz (type A), but they are also sensitive to:

- alternating currents up to a frequency of 1000 Hz;
- alternating and/or pulsating currents with DC components overlapping with a direct current;
- earth fault currents generated by a rectifier with two or more phases;
- direct earth fault currents without residual ripple

...independently of the polarity or whether the earth fault current appears suddenly or increases gradually.

Type B RCDs must be marked with the following symbols highlighting the switches' capacity to detect every type of current: .

Construction features

Type B RCDs consist of one section for the detection of alternating earth fault currents and unidirectional pulsating earth fault currents, which functions independently of the line voltage. For the detection of direct earth fault currents or currents with a minimum residual ripple, type B RCDs have a second electronic section, the functioning of which depends on the line voltage. The structure of the product is illustrated in the following diagram.

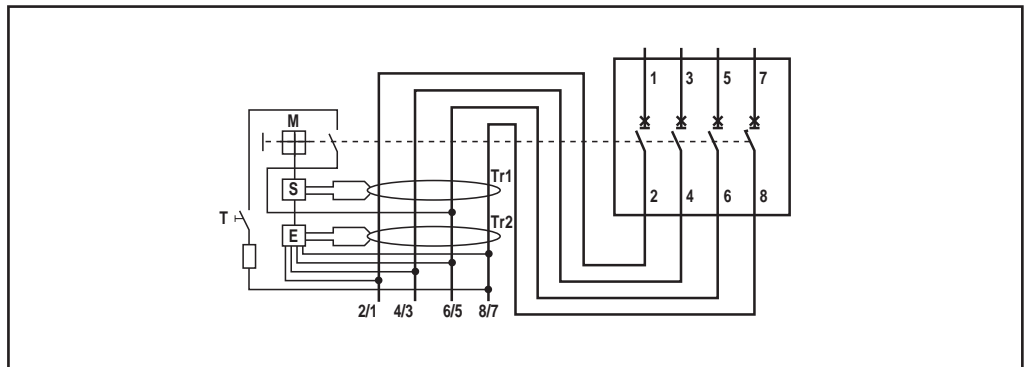

- S** Release
- M** Protection device mechanism
- E** Electronics for the intervention with direct unidirectional earth fault currents
- T** Test device
- Tr1** Residual current transformer for the detection of sinusoidal earth fault currents
- Tr2** Residual current transformer for the detection of direct unidirectional currents.

The residual current transformer Tr1 monitors the presence of pulsating and alternating earth fault currents in the electronic installation while residual current transformer Tr2 measures the direct unidirectional currents. In the event of a fault the second transformer transmits the opening command to the release S via the (printed) circuit board E. In type B RCCBs, the section whose functioning depends on the line voltage is supplied by all three-phase conductors and the neutral, so that the functioning as type B is guaranteed even if there is a voltage only in two of the 4 power conductors. In addition, the supply of the electronic section is sized in such a way that the device can safely intervene even if there is a voltage drop of 70%. In this way an intervention takes place when direct unidirectional earth fault currents emerge, even in the event of faults in the electric power supply grid, for example if there is no neutral conductor.

Direct or similar earth fault currents

An increasing amount of industrial equipment is supplied by circuits which in the event of a fault generate direct earth fault currents with a very low residual ripple, which can be even less than 10%. For example with direct current supplied motor drives for pumps, elevators, textile machines etc. it is becoming more common to use inverters with a three-phase rectifier bridge. In the event of an earth fault current the wave of the earth fault is as indicated in the figure below.

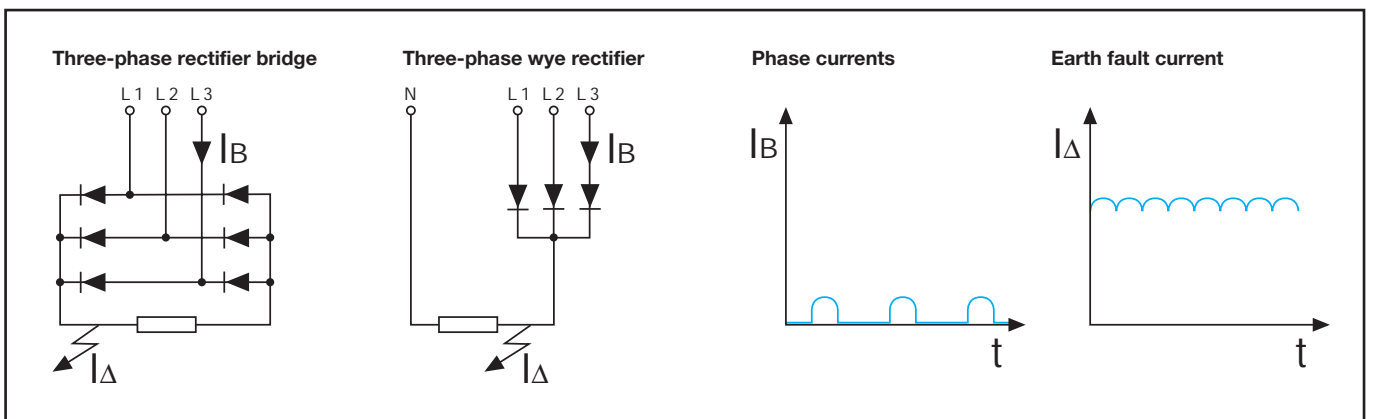

Use of 4P RCCBs in 3-phase system without neutral pole

Use of a 4P RCCB in a 3-phase circuit without neutral

The test button circuit of these RCCBs 4P F 200 is wired inside the device between terminal 5/6 and 7/8/N as indicated below, and has been sized for an operating voltage between 110 and 254 V (110 and 277 V according to UL 1053).

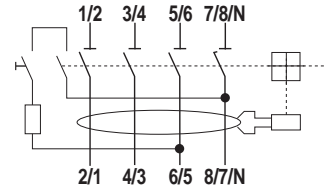

In case of installation in a 3 phase circuit without neutral, if the concatenate voltage is between 110 and 254 V (277 V according to UL 1053) for the correct working of the test button there are two possible solutions:

- 1) To connect the 3 phases to the terminals 3/4 5/6 7/8/N and the terminals 4/3 6/5 8/7/N (supply and load side respectively)
- 2) To connect the 3 phases normally (supply to terminals 1/2 3/4 5/6 and load to terminals 2/1 4/3 6/5) and to bridge terminal 1/2 and 7/8/N in order to bring to the terminal 7/8/N the potential of the first phase. In this way the test button is supplied with the phases' concatenate voltage.

If the circuit is supplied with a concatenate voltage higher than 254 V, as in the typical case of 3 phase net with concatenate voltage of 400 V - or 480 V according to UL 1053 - (and voltage between phase and neutral of 230 V or 277 V according to UL 1053), it is not possible to use these connections because the circuit of the test button will be supplied at 400 V and could be damaged by this voltage.

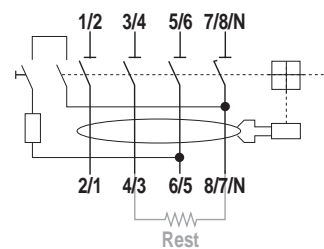

$I_{\Delta n}$ [A]	Rest [Ω]
0.03	3300
0.1	1000
0.3	330
0.5	200

In order to allow the correct operation of the test button also in 3 phase nets at 400 V - 480 V according to UL 1053 - (concatenate voltage) it is necessary to connect normally the phases (supply to terminals 1/2 3/4 5/6 and load to terminals 2/1 4/3 6/5) and to jump terminal 4/3 and 8/7/N by mean of an electric resistance as indicated above.

In this way the test button circuit is fed at 400 V - 480 V according to UL 1053 - but for example in an RCCB with $I_{\Delta n}=0.03$ A there will be the $R_{est}=3.3$ kOhm resistance in series to the test circuit resistance. R_{est} will cause a voltage drop that leaves in the test circuit a voltage less than 254 V - 277 V according to UL 1053. R_{est} resistance must have a power loss higher than 4 W.

In the normal operation of the RCCB (test circuit opened) the R_{est} resistance is not fed so it does not cause any power loss.

The solution RCCBs with neutral pole on left side

The test button circuit of these RCCBs is wired inside the device between terminal 3/4 and 5/6 as indicated below, and it has been sized for an operating voltage between 195 V and 440 V - 480 V according to UL 1053. In case of a three phase system without neutral with concatenate voltage between phases of 230 V or 400 V - 277 V or 480 V according to UL 1053 - it is enough to connect the 3 phases normally (supply to terminals 1/2 3/4 5/6 and load to terminals 2/1 4/3 6/5) without any bridge.

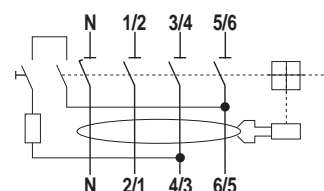

Operating voltage of test button

The operation of RCDs depends on the maximum and minimum operating voltage of the test button.

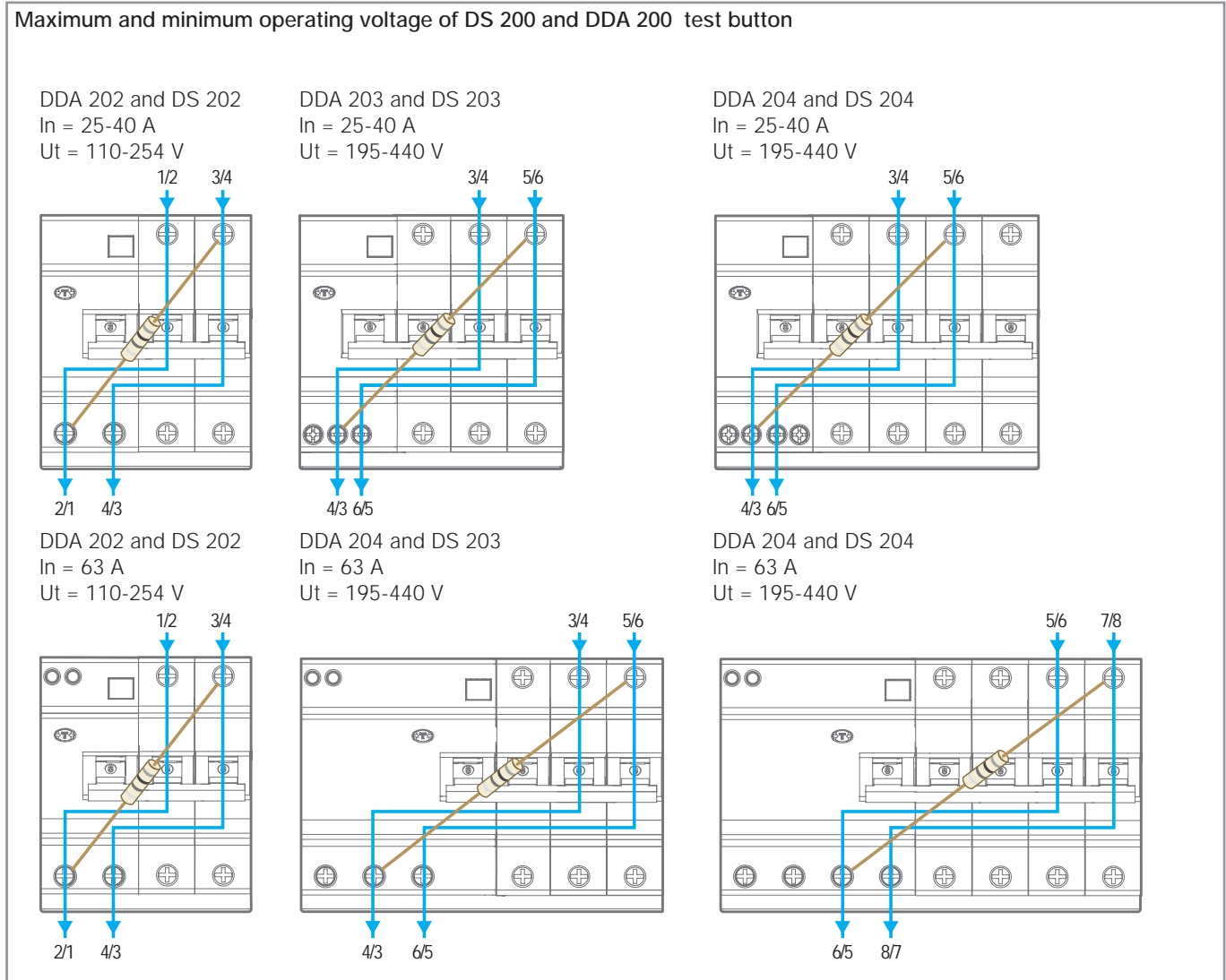
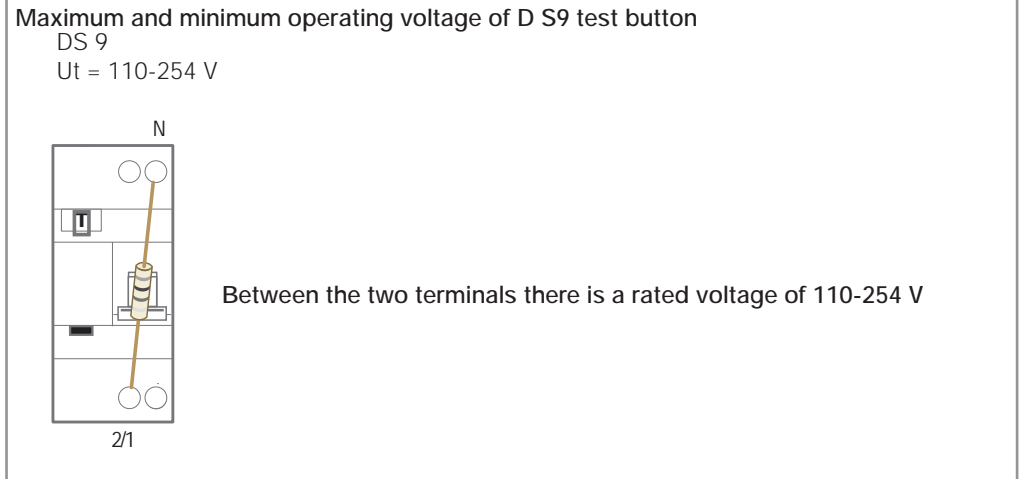

Maximum and minimum operating voltage of DDA 200 AE test button

DDA 202 AE
In = 63 A
Ut = 184-264 V

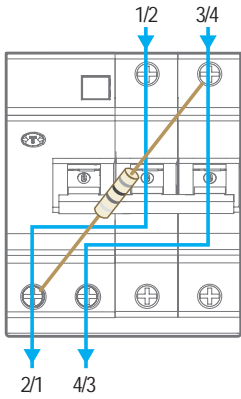

DDA 203 AE
In = 63 A
Ut = 310-440 V

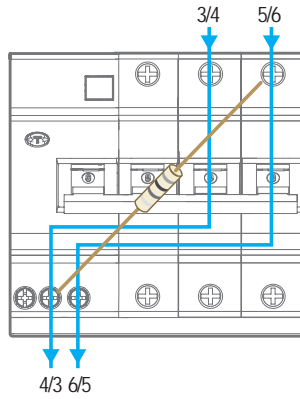

DDA 204 AE
In = 63 A
Ut = 184-264 V

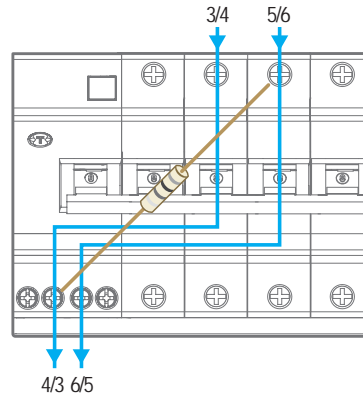

Maximum and minimum operating voltage of DDA 200 B type test button

DDA 204 B
In = 63 A
Ut = 195-440 V

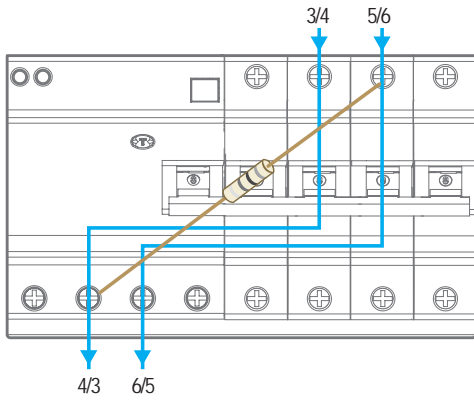

Maximum and minimum operating voltage of F 200 standard test button

F 202 standard
 $I_n = \leq 100 \text{ A}$
 $U_t = 110-254 \text{ V}$

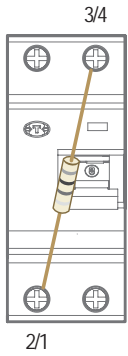

F 204 standard
 $I_n = \leq 100 \text{ A}$
 $U_t = 110-254 \text{ V}$

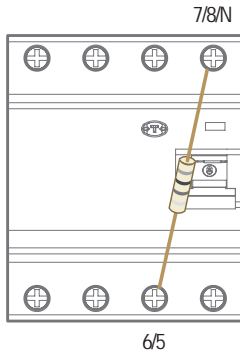

F 204 standard
 $I_n = 125 \text{ A}$
 $U_t = 185-440 \text{ V}$

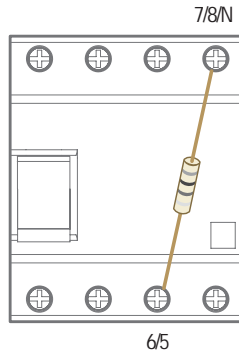

Maximum and minimum operating voltage of F 200 B type test button

F 204 B
 $I_n = 63 \text{ A}$
 $U_t = 185-440 \text{ V}$

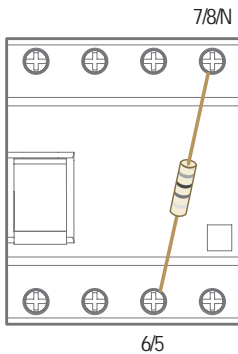

Maximum and minimum operating voltage of F 200 (N on the left) test button

F 204 neutral on left
 $I_n = \leq 100 \text{ A}$
 $U_t = 195-440 \text{ V}$

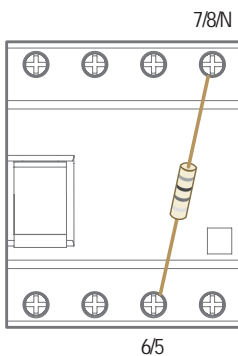

For use in 3-phases circuit without neutral at 400 V it is possible to connect the three phases R, S and T like in the figure.

Maximum and minimum operating voltage of DDA 60-70-90 test button

DDA 62, DDA 72, DDA 92 with S 290
 $I_n = 100\text{ A}$
 $U_t = 100\text{-}240\text{ V}$

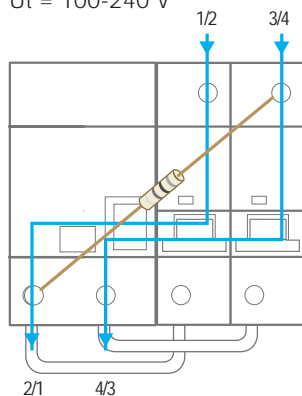

DDA 64, DDA 74, DDA 94 with S 290
 $I_n = 100\text{ A}$
 $U_t = 175\text{-}415\text{ V}$

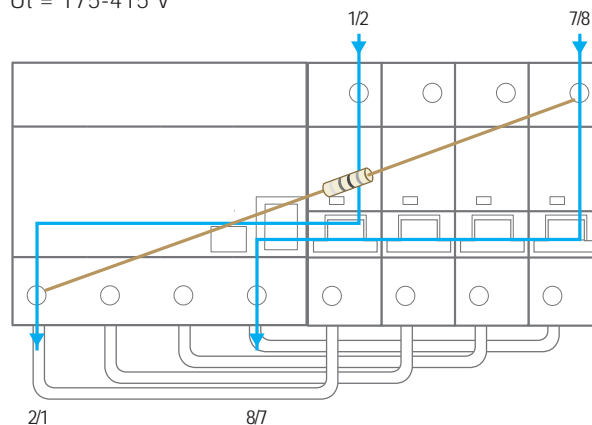

Maximum and minimum operating voltage of DDA 800 and DS800 test button

DDA 802
 DS802
 $I_N \leq 125\text{ A}$
 $U_t = 195\text{-}690\text{ V}$

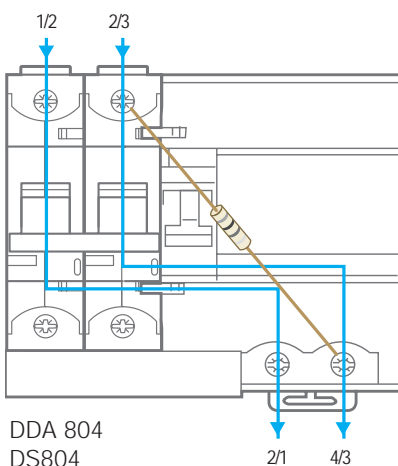

DDA 803
 DS803
 $I_N \leq 125\text{ A}$
 $U_t = 195\text{-}690\text{ V}$

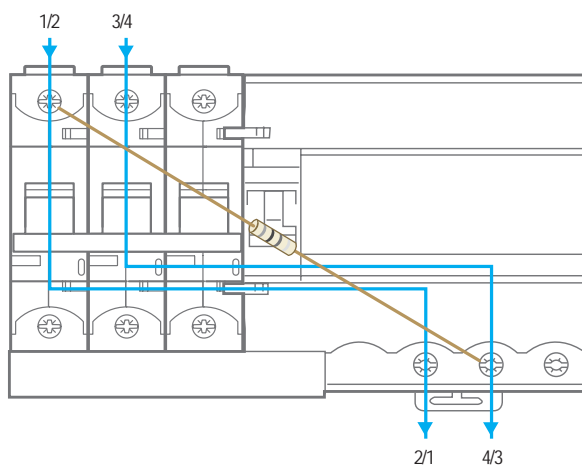

DDA 804
 DS804
 $I_N \leq 125\text{ A}$
 $U_t = 195\text{-}690\text{ V}$

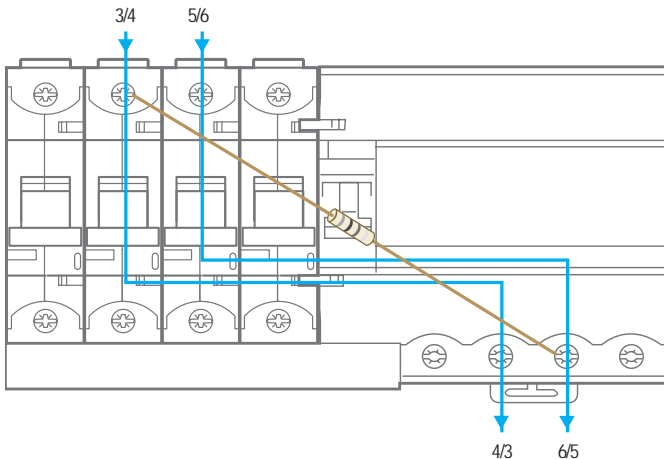

RCDs

F 202

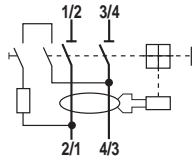

F 204

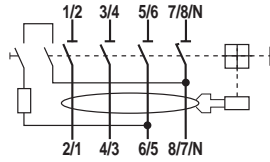

F 204 Left neutral

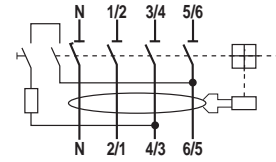

F 204 B type

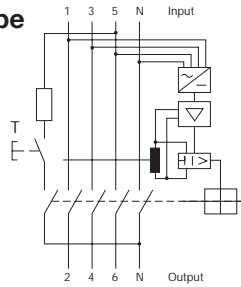

RCD-blocks

DDA 202

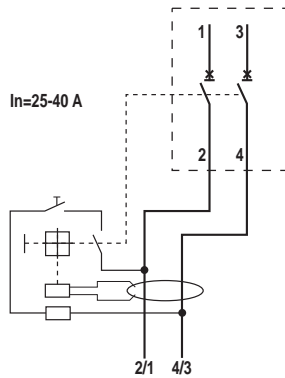

DDA 203

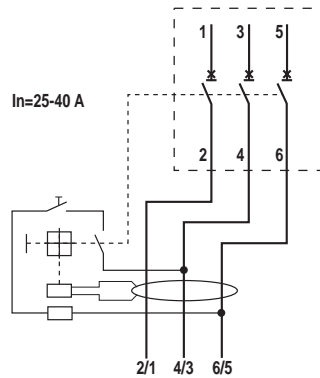

DDA 204

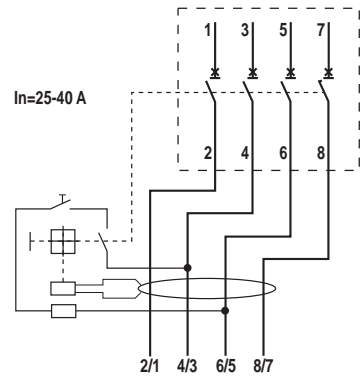

DDA 202

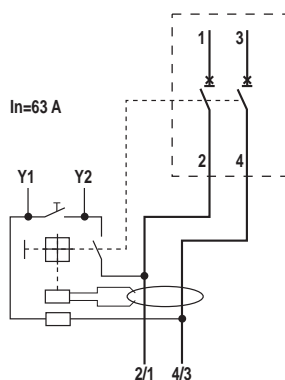

DDA 203

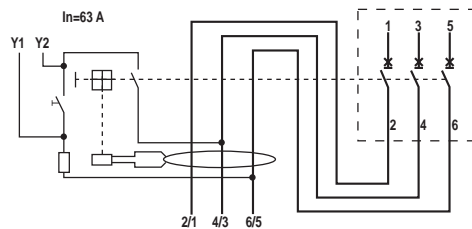

DDA 204

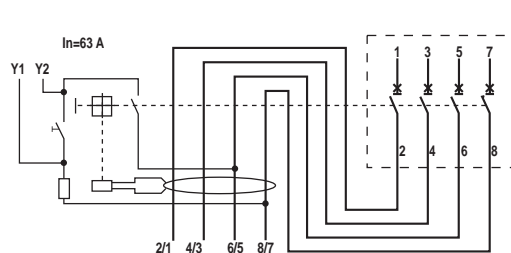

RCD-blocks

DDA 202 AE

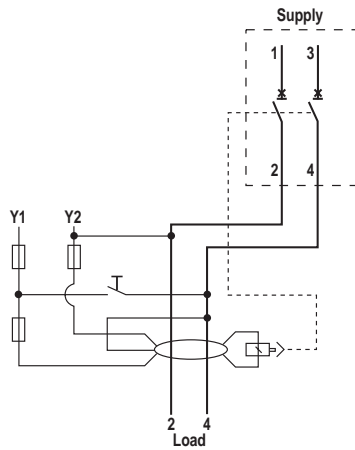

DDA 203 AE

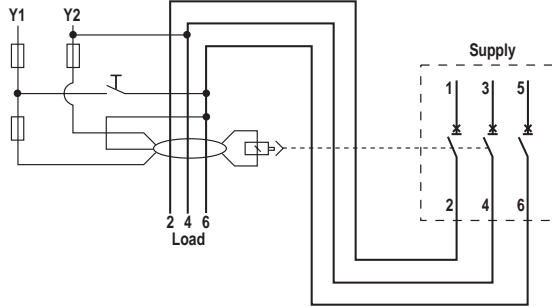

DDA 204 AE

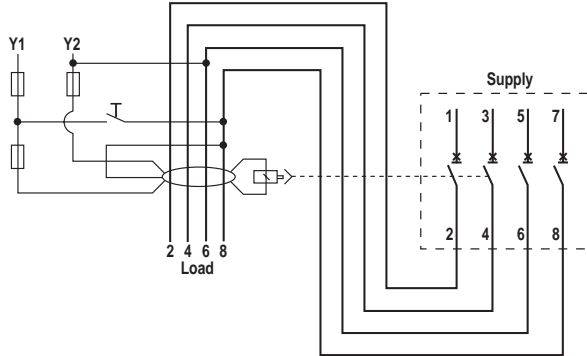

DDA 204 B type

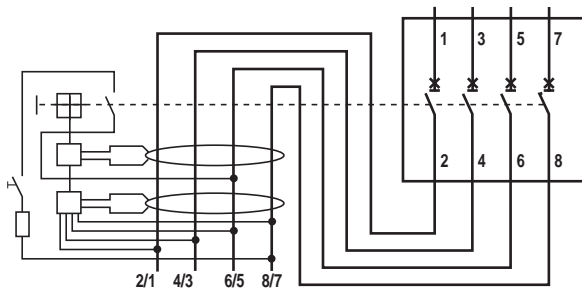

RCBOs

FS 201

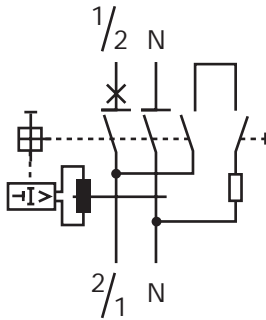

DS 202

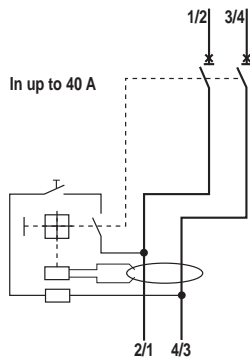

DS 203

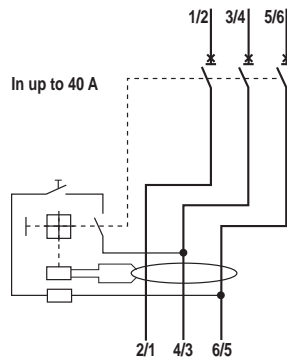

DS 204

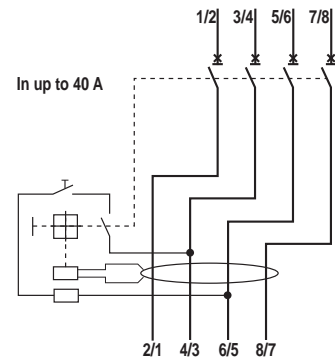

DS 202

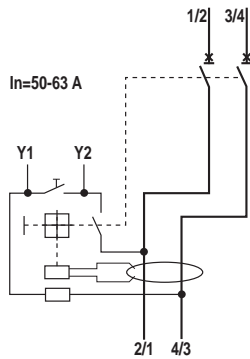

DS 203

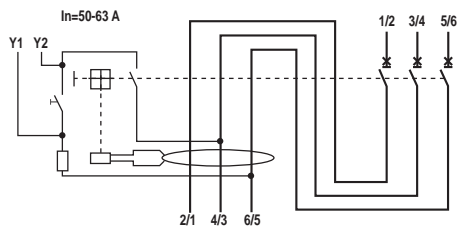

DS 204

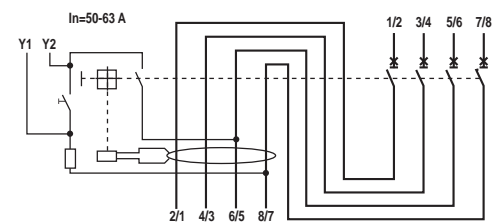

SURGE PROTECTIVE DEVICES OVR RANGE

Terminology of SPD electrical characteristics

10/350 and 8/20 impulse waves

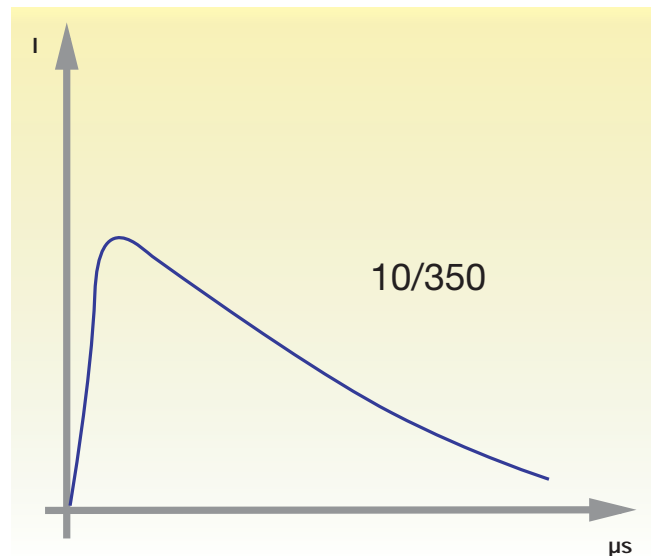

Type 1 Surge Arresters
 I_{imp} : current wave

10/350 wave:

Current waveform which passes through equipment when subjected to an overvoltage due to a direct lightning strike.

Type 1 surge arrester:

Surge arrester designed to run-off energy caused by an overvoltage comparable to that of a direct lightning strike. It has successfully passed testing to the standard with the 10/350 wave (class I test).

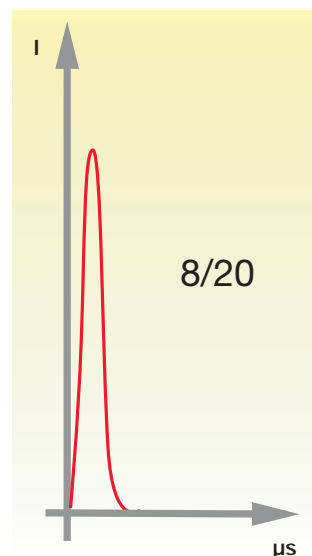

Type 2 Surge Arresters
 I_{max} : current wave

8/20 wave:

Current waveform which passes through equipment when subjected to an overvoltage (low energy).

Type 2 surge arrester:

Surge arrester designed to run-off energy caused by an overvoltage comparable to that of an indirect lightning strike or an operating overvoltage. It has successfully passed testing to the standard with the 8/20 wave (class II test).

Common mode and/or differential mode protection

Common mode

Common mode overvoltages appear between the live conductors and earth, e.g. phase/earth or neutral/earth.

A live conductor not only refers to the phase conductors but also to the neutral conductor. This overvoltage mode destroys equipment connected to earth (class I equipment) and also equipment not connected to earth (class II equipment) which is located near an earthed mass and which does not have sufficient electrical isolation (a few kilovolts). Class II equipment not located near an earthed mass is theoretically protected from this type of attack.



Note:
Common mode overvoltages affect all earthing systems.

Differential mode

Differential mode overvoltages circulate between live conductors: phase/phase or phase/neutral. These overvoltages have a potentially high damaging effect for all equipment connected to the electrical network, especially 'sensitive' equipment.



Note:
Differential mode overvoltages affect the TT earthing system. These overvoltages also affect the TN-S earthing system if there

is a considerable difference in the lengths of the neutral cable and the protective cable (PE).

Note:

The coordination of Type 2 surge arresters is analysed using their respective maximum discharge currents I_{max} (8/20) starting from the installation's incoming switchboard and working towards the equipment which is to be protected, taking into account the progressive reduction in I_{max} .

E.g. 70 kA followed by 40 kA.

All ABB Type 2 surge arresters coordinate between each other by respecting a minimum distance of 1m between them.

Principle of coordination for Surge Protective Devices

After having defined the characteristics of the incoming surge arrester, the protection must be completed with one or more additional surge arresters.

The incoming surge arrester does not provide effective protection for the whole installation by itself.

Certain electrical phenomena can double the protection's residual voltage if cable lengths exceed 10m.

Surge arresters must be coordinated when they are installed (refer to the tables below).

Coordination required if:

The incoming surge arrester does not reach the protection voltage (U_p) by itself.

The incoming surge arrester is more than 10m away from the equipment to be protected.

Recommended solution

Use of modular Type 2 surge arresters.

Coordination between Type 1 and Type 2 surge arrester

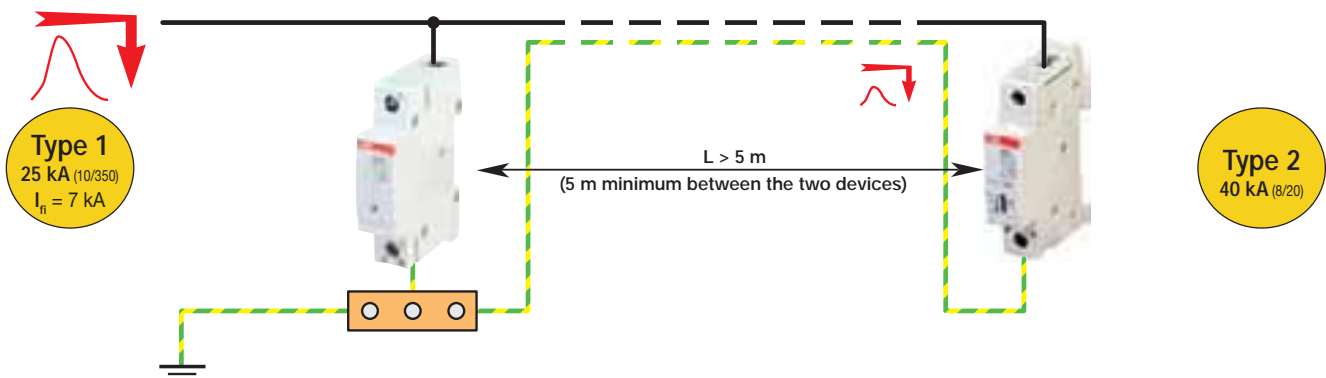
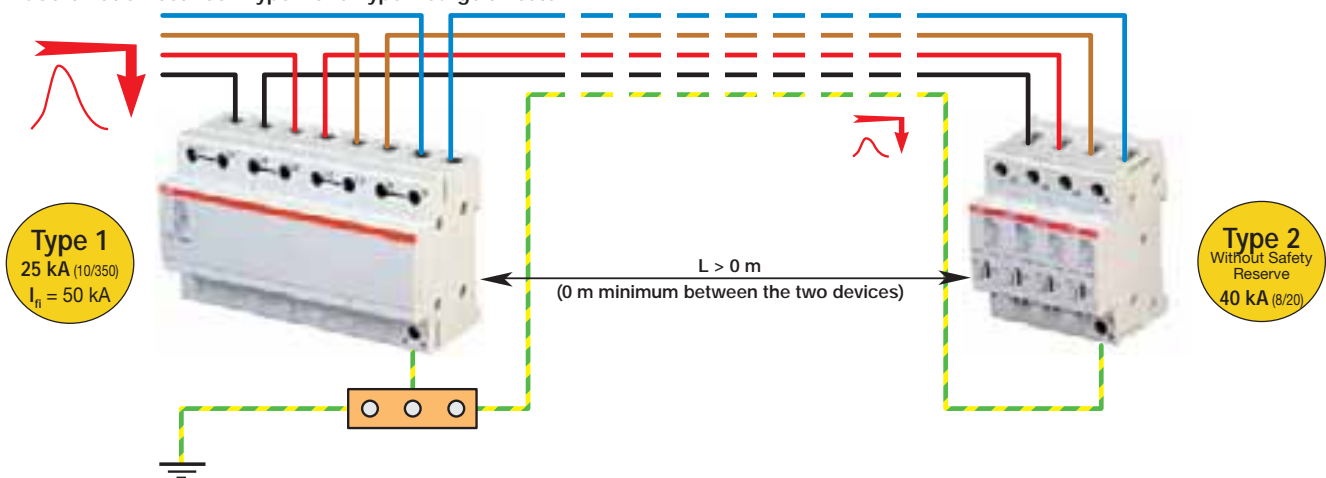

Coordination between Type 2 surge arresters

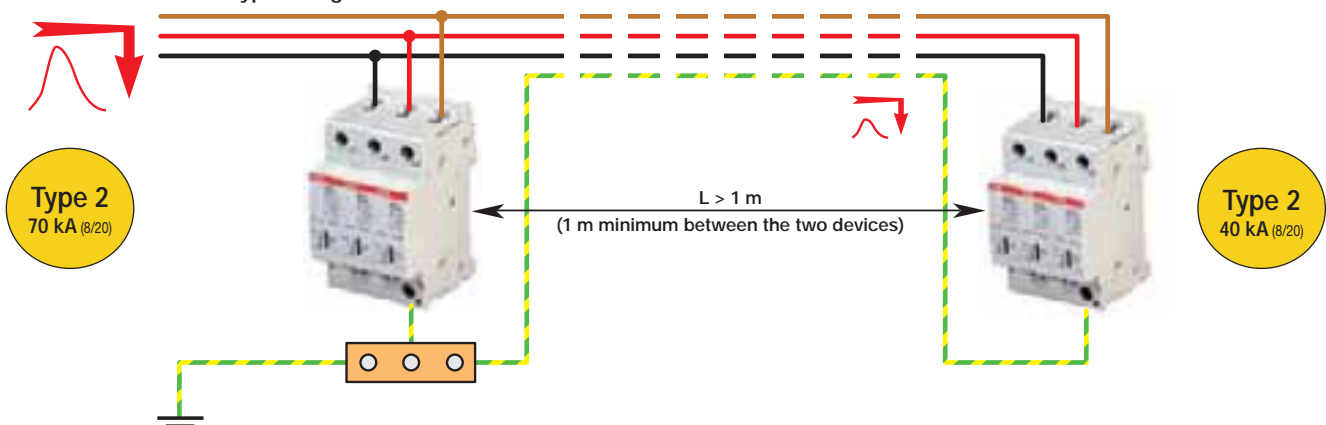

Operating diagrams of Surge Protective Devices

Type 1 internal schematic

Single pole Type 1 SPD

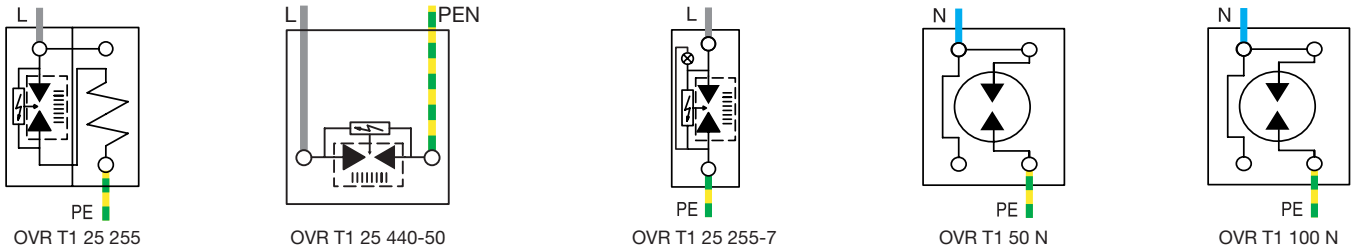

Multipole Type 1 SPD

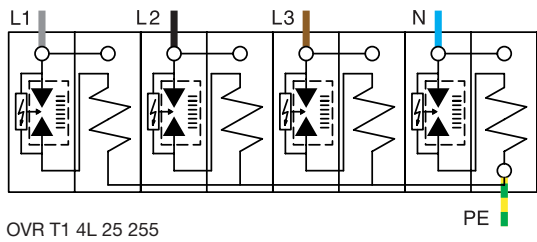
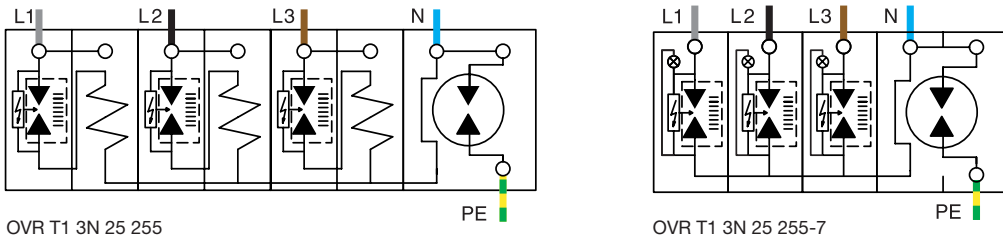
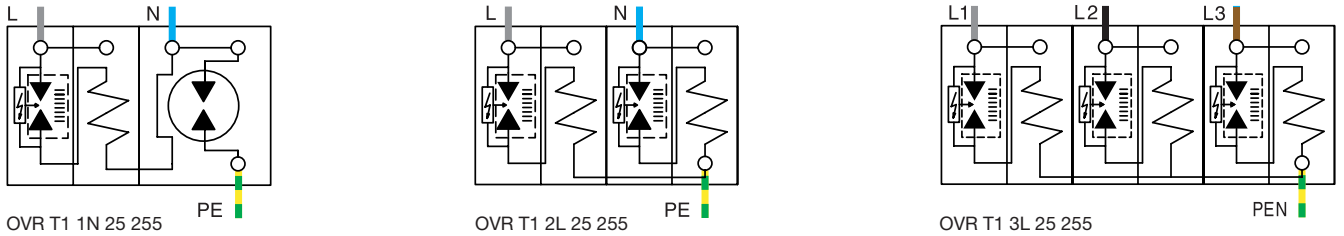

Multipole Type 1 SPD with remote indication (TS)

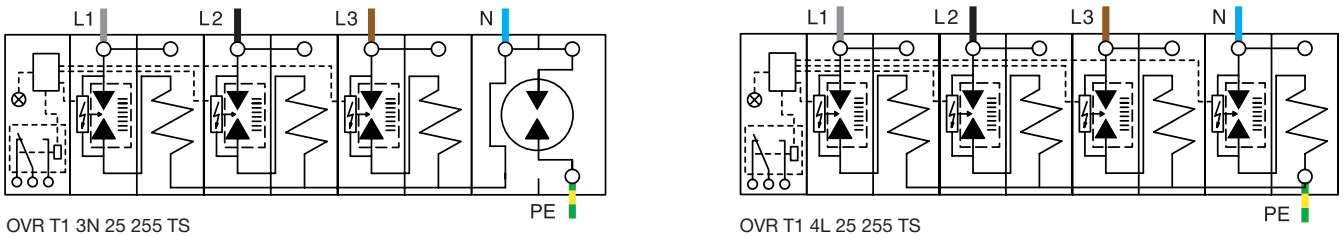
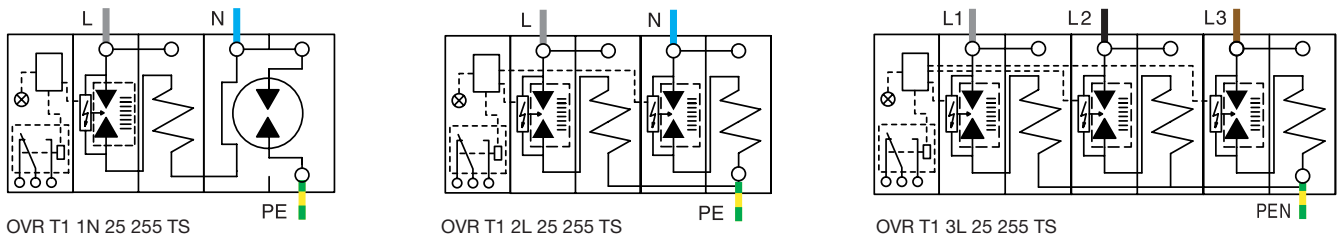

Photovoltaic SPDs - OVR PV

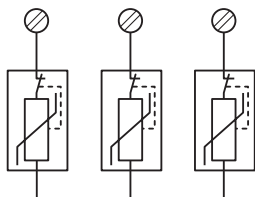

OVR PV 1000 V

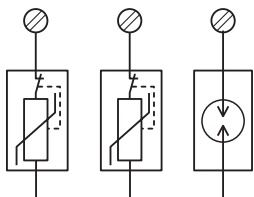

OVR PV 600 V

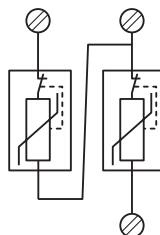

OVR PV 75 V

Low Current SPDs - OVR TC

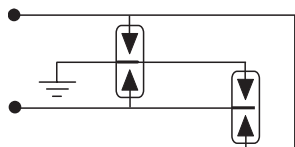

OVR TC 200 V in parallel

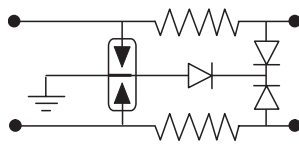

OVR TC / xx V / 200 FR in series

Type 1+2 internal schematic

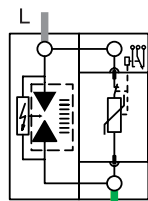

PE

OVR T1+2 25 255 TS

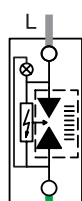

PE

OVR T1+2 15 255-7

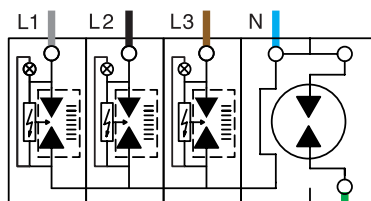

PE

OVR T1+2 3N 15 255-7

Type 1+2 / Type 2 internal schematic

Non pluggable Type 2 SPDs

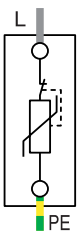

PE

OVR T2 40 275
OVR T2 15 275

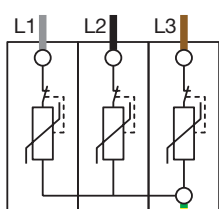

PE

OVR T2 3L 40 275

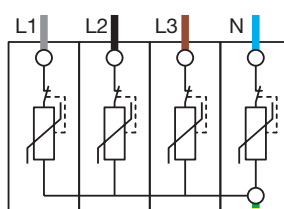

PE

OVR T2 4L 40 275

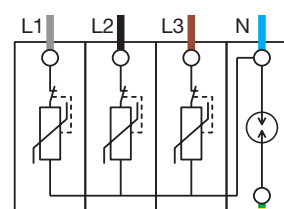

PE

OVR T2 3N 40 275

11

Pluggable Type 1+2 / Type 2 SPDs

Single pole Type 2 SPD

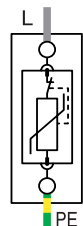

PE

OVR T2 15 275 P
OVR T2 40 275 P
OVR T2 15 440 P
OVR T2 40 440 P

Single pole Type 2 SPD with safety reserve (s)

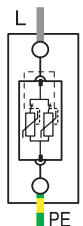

PE

OVR T2 40 275s P
OVR T2 70 275s P
OVR T2 40 440s P
OVR T2 70 440s P
OVR T1+2 7 275s P

Single pole Type 2 SPD with remote indication (TS)

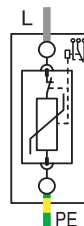

PE

OVR T2 15 275 P TS
OVR T2 40 275 P TS
OVR T2 15 440 P TS
OVR T2 40 440 P TS

Single pole Type 2 SPD with safety reserve (s) and remote indication (TS)

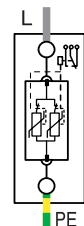

PE

OVR T2 40 275s P TS
OVR T2 70 275s P TS
OVR T2 40 440s P TS
OVR T2 70 440s P TS

Multipole Type 2 SPD

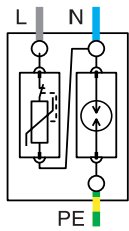

OVR T2 1N 15 275 P
OVR T2 1N 40 275 P

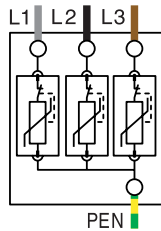

OVR T2 3L 15 275 P
OVR T2 3L 40 275 P

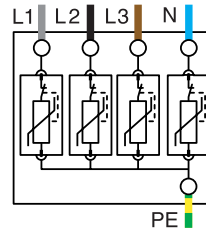

OVR T2 4L 15 275 P
OVR T2 4L 40 275 P

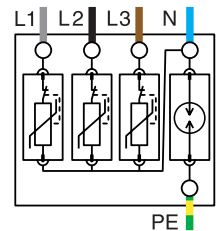

OVR T2 3N 15 275 P
OVR T2 3N 40 275 P

Multipole Type 2 SPD with safety reserve (s)

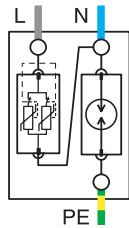

OVR T2 1N 40 275s P
OVR T2 1N 70 275s P
OVR T1+2 1N 7 275s P

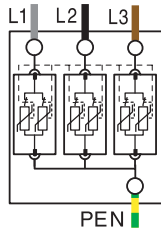

OVR T2 3L 40 275s P
OVR T2 3L 70 275s P
OVR T1+2 3L 7 275s P

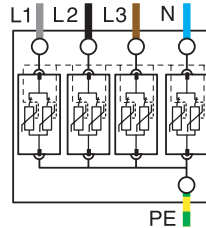

OVR T2 4L 40 275s P
OVR T2 4L 70 275s P
OVR T1+2 4L 7 275s P

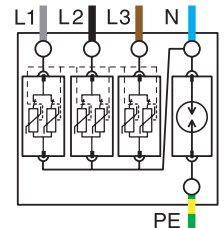

OVR T2 3N 40 275s P
OVR T2 3N 70 275s P
OVR T1+2 3N 7 275s P

Multipole Type 2 SPD with remote indication (TS)

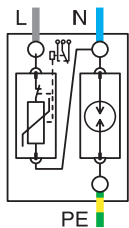

OVR T2 1N 15 275 P TS
OVR T2 1N 40 275 P TS

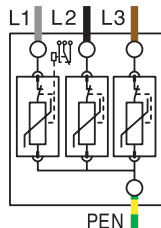

OVR T2 3L 15 275 P TS
OVR T2 3L 40 275 P TS

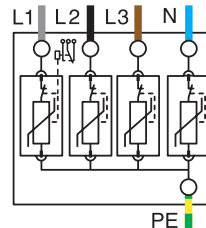

OVR T2 4L 15 275 P TS
OVR T2 4L 40 275 P TS

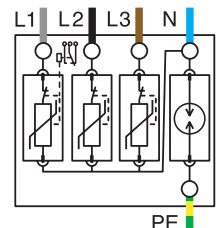

OVR T2 3N 15 275 P TS
OVR T2 3N 40 275 P TS

Multipole Type 2 SPD with safety reserve (s) and remote indication (TS)

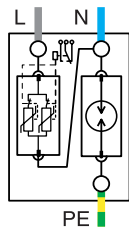

OVR T2 1N 40 275s P TS
OVR T2 1N 70 275s P TS

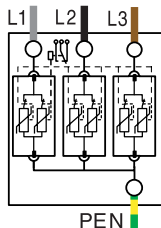

OVR T2 3L 40 275s P TS
OVR T2 3L 70 275s P TS

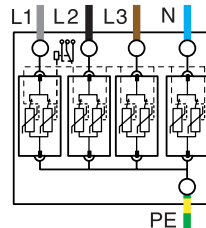

OVR T2 4L 40 275s P TS
OVR T2 4L 70 275s P TS

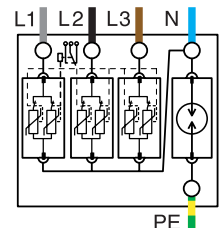

OVR T2 3N 40 275s P TS
OVR T2 3N 70 275s P TS

Installation rules for SPDs: choice of associated breaking devices (fuse/circuit-breaker)

Choice of disconnector

Surge arresters must be associated with upstream short-circuit protection and residual current protection against indirect contact (usually already present in the installation).

	Function	Application
	Protection against indirect contact	<ul style="list-style-type: none"> Residual current circuit-breaker compulsory for TT systems Residual current circuit-breaker possible for TN-S, IT and TN-C-S systems Residual current circuit-breaker forbidden for TN-C systems If a residual current circuit-breaker is used, it is preferable to use a type S.
	Protection against fault currents	The breaking device associated with the surge arrester can be either a circuit breaker or a fuse. Its rating should take into consideration the surge arrester's characteristics and the short-circuit current of the installation.
	Thermal protection	Thermal protection is integrated into the surge arrester.

Maximum circuit-breaker or fuse protection rating depending on I_{max} and I_{imp} of the surge arrester.

Type 1 surge arresters	Circuit-breaker (curve C)	Fuse (gG)
25 kA (10/350): OVR T1	-	≤ 125 A
Type 1+2 surge arresters	Circuit-breaker (curve C)	Fuse (gG)
7 kA (10/350): OVR T1+2		
• $I_p = 300$ A to 1 kA	40 A (1)	32 A
• $I_p = 1$ kA and above	63 A (2)	32 A
Type 2 surge arresters	Circuit-breaker (curve C)	Fuse (gG)
70 kA (8/20)		
• $I_p = 300$ A to 1 kA	40 A (1)	32 A
• $I_p = 1$ kA and above	63 A (2)	32 A
40 kA (8/20)		
• $I_p = 300$ A to 1 kA	40 A (1)	32 A
• $I_p = 1$ kA and above	63 A (2)	32 A
15 kA (8/20)		
• $I_p = 300$ A to 1 kA	40 A (1)	32 A
• $I_p = 1$ kA and above	63 A (2)	32 A

(1) Series S 200 L or S 941 N.

(2) Series S 200 L, S 200 / S 200 M and series S 200 P / S 500 / S800.

Cabling and installation of Surge Protective Devices in an electrical panel

50 cm rule

Remember that a 10 kA lightning current passing through a 1 m length of cable generates 1000 Volts. Equipment protected by a surge arrester is subjected to a voltage equal to the sum of the U_p voltage of the surge arrester, U_d of its disconnector and the sum of the inductive voltages of connecting cables ($U_1+U_2+U_3$).

It is therefore essential that the total length ($L = L_1+L_2+L_3$) of the connecting cables is as short as possible (0.50 m).

If this length ($L = L_1 + L_2+L_3$) exceeds 0.50m, it is necessary to carry out one of the following:

- Reduce this length by moving the connection terminals.
- Choose a surge arrester with a lower U_p value.
- Install a second, coordinated surge arrester near the device to be protected so as to adapt the combined U_p value to the impulse withstand of the equipment to be protected.

Wiring ring surfaces

The wires must be arranged in such a way that they are as close to each other as possible (see adjacent diagram) to avoid overvoltages induced by a ring surface between phases, the neutral and the PE conductor.

Routing of clean cables and polluted cables

During installation, lay clean cables (protected) and polluted cables as shown in the adjacent diagrams.

To avoid magnetic coupling between the different cable types (clean and polluted), it is strongly advised that they are kept apart (> 30 cm) and if a crossing cannot be avoided, it should be at right angles (90°).

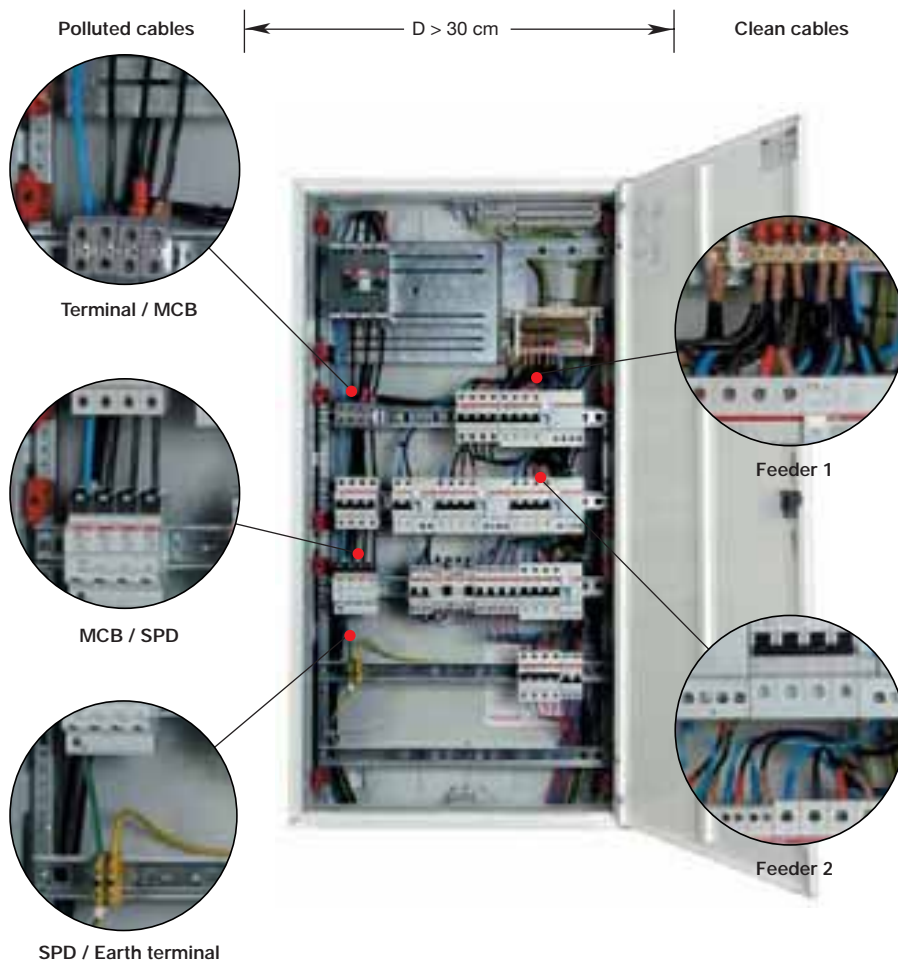
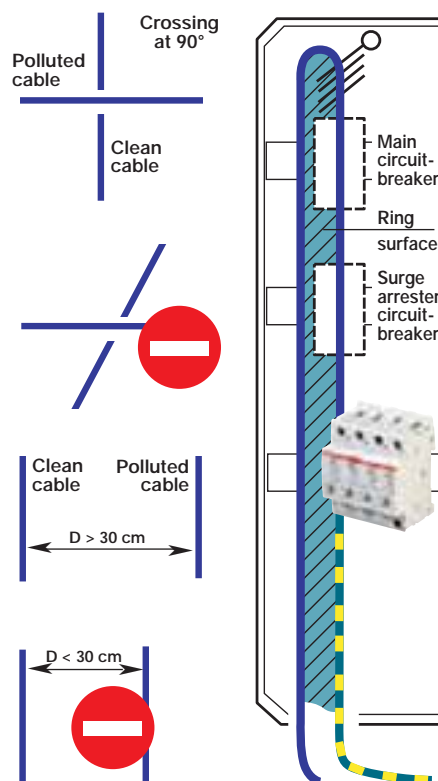
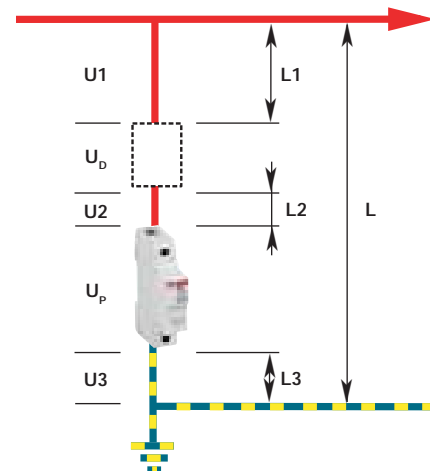

Note

The cross-section of the connecting cables is calculated according to the local short-circuit current level (where the surge arrester is installed). It must be equal to the cross-section of the installation's upstream cables.

The minimum cross-section for the earth conductor is 4 mm² if there is not a lightning conductor and 10 mm² if there is a lightning conductor.

Equipotential grounding:

It is critical to check the earth equipotentiality of the various items of equipment.

RD2 RESIDUAL CURRENT MONITORS

They operate combined with appropriate toroidal transformers (in 9 different diameters) which perform the sum of line currents; any current leakage in the monitored circuit causes, in the secondary of the toroidal transformer, a signal detected by the relay which intervenes.

The relay can command the tripping of the protection circuit-breaker release, thus breaking the circuit.

According to the IEC 60755 Standard, these relays are sensitive to leakage sinusoidal currents and to leakage pulsating currents with direct components. Thus they can be defined as "A type".

Some electric circuits allow to adjust sensitivity and time; the values can be selected through appropriate minidips.

More technical characteristics

Calibration tolerances	- sensitivity	+0% -50%
	- time	+0% -50%
Power consumption	[W]	0.45 at 48 V AC/DC 1.2 at 110 V AC/DC 3.4 at 230 V AC 11 at 400 V AC
Dielectric test voltage at ind. freq. for 1 min.	[kV]	2.5
Max. peak current with 8/20 μ s wave	[A]	5000
Installation position		any
Protection degree		IP20



TEPM0270

Toroidal transformers

More technical characteristics

	TRM	TR1	TR2	TR3	TR4	TR4A	TR160	TR160A	TR5	TR5A
Core	closed	closed	closed	closed	closed	open	closed	open	closed	open
Available internal diameter [mm]	29	35	60	80	110	110	160	160	210	210
Weight [kg]	0.17	0.22	0.28	0.45	0.52	0.6	1.35	1.6	1.45	1.85
Minimum measurable current [mA]	30	30	30	100	100	300	300	500	300	500
Installation position	Any									
Operating temperature [°C]	-10...+70									
Storage temperature [°C]	-20...+80									
Transformation ratio	500/1									
Dielectric test voltage at industrial freq. for 1 min. [kV]	2.5									
Max. permanent overload [A]	1000									
Max. thermal overload [kA]	40/1 sec.									
Connections	Screw terminal boards, max. section 2.5 mm ²									
Protection degree	IP20									

Generality

They must be mounted with residual current monitors upstream the lines or loads to be protected; all active conductors (phases and neutral) of single-phase as well as of three-phases lines must pass through them.

In this way these devices perform the vector sum of line currents detecting the possible homopolar differential currents that leak to earth: their core of sheet iron has high magnetic properties that allow to detect even very low leakage currents.

The choice of a toroidal transformer depends on the conductor or on the bar to be used.

It is suggested to use the open versions in case of revamping or upgrading of an existing installation.

Installation

All active conductors can be introduced in the toroidal transformers without the need of respecting any specific sense of introduction (P1-P2 or P2-P1). The output signal must be picked up from terminals 1 (S1) and 2 (S2) and connected to the residual current monitor, while terminals 3 and 4 must be connected to the test output of those relays of FPP range with this function. With RD2 they must remain disconnected. For this connection it is better to use twisted or shielded cables, possibly far from busbars. The minimum recommended section of connection cables should have a maximum resistance of 3 Ω; anyway consider a maximum length of connection of 20 m for 0.5 mm² and of 100 m for 2.5 mm².

For versions with openable core it is necessary to control that the contact surface of the two semi-cores is clean, that bolts are tight and that connection cables connections on both sides are intact.

Connection cables with metallic shielding or armor must be earthed downstream the toroidal transformer; if they run within the transformer they must be earthed in the opposite direction.

In presence of line overcurrents (for ex. motor operation, energizing of transformers, etc.):

- install the toroidal transformer on a straight cable segment

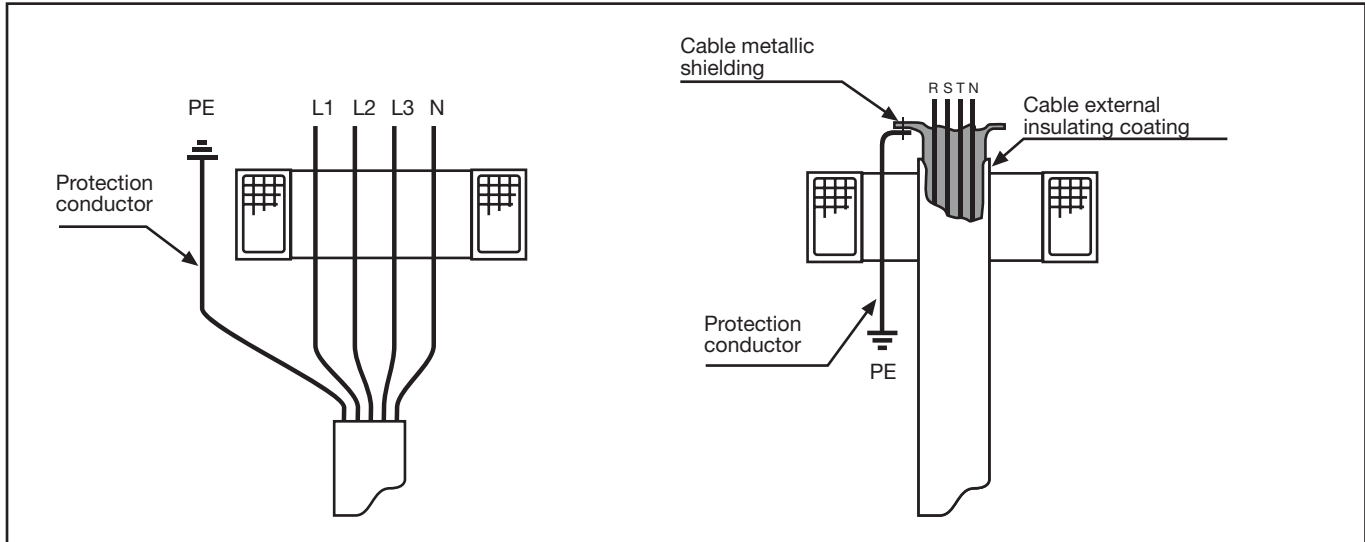

- center cable position within the transformer
- use transformers with a diameter wider than minimum requirements, if necessary with a diameter up to 2 times wider than that of cables.

Coordination table of toroidal transformers acc. to cable section

Copper cables 3 ph + N

Max section per phase	Toroidal Transformer
16 mm ²	TRM
25 mm ²	TR1
50 mm ²	TR2
95 mm ²	TR3
240 mm ²	TR4 or TR4/A
2 x 150 mm ²	TR160 or TR160/A
2 x 185 mm ²	TR5 or TR5/A



E 930 FUSE HOLDERS

More technical characteristics

Breaking capacity	that of the cartridge	
Dielectric test voltage at ind. freq. for 1 min.	2.5 kV	
Terminals	up to 32 A	10 mm ²
	up to 50 A	25 mm ²
	up to 125 A	35 mm ²
Protection degree	IP20	
Rated voltage Un	E930/32 (10.3x38 fuses)	400 V*

* E930/32 fuse holders comply with IEC EN 60269-3 Standard (fuse for domestic applications) and they have been released with Un=400 V; by construction, they can be used up to 500 V.

Power consumption in Watt at rated current

Fuse rating In [A]	Fuses 10.3x38 gG	Fuses 14x51 gG	Fuses 22x58 gG
1	0.272	0.50	0.80
4	1.05	0.95	1.45
6	1.10	1.30	1.60
8	1.20	1.60	2.15
10	1.30	1.90	2.50
12	1.50	2.10	2.70
16	1.80	2.20	2.75
20	2.00	2.30	2.90
25	2.30	3.00	3.40
32	2.60	3.30	3.60
40		3.60	4.50
45		4.10	4.80
50		5.00	5.50
63			6.35
80			7.35
100			8.75
125			12.50

Power consumption in Watt at rated current

Fuse rating In [A]	Fuses 10.3x38 aM	Fuses 14x51 aM	Fuses 22x58 aM
1	0.08		
2	0.12		
4	0.17	0.25	0.30
6	0.30	0.30	0.45
8	0.35	0.40	0.55
10	0.40	0.50	0.60
12	0.45	0.65	0.75
16	0.70	0.90	0.90
20	1.00	1.00	1.10
25	1.20	1.20	1.35
32	1.50	1.55	1.60
40		2.10	1.90
45		2.15	2.20
50		2.50	3.00
63			4.10
80			5.20
100			6.50
125			7.80

Maximum values of specific let-through energy in A²s

In [A]	gL fuses	
	Pre-arc	Total
1	3	15
2	5	30
4	15	110
6	60	200
8	80	330
10	130	400
12	250	700
16	450	1500
20	800	2700
25	1400	4500
32	2200	7000
40	3500	11000
45	4000	15000
50	4500	17000
63	9300	27000
80	20000	65000
100	40000	100000
125	70000	160000

Maximum values of specific let-through energy in A²s

In [A]	aM fuses	
	Pre-arc	Total
1	10	20
2	35	60
4	110	270
6	200	600
8	400	1100
10	800	2000
12	1000	2800
16	1200	4500
20	1700	7000
25	2700	11000
32	5000	19000
40	9000	28000
45	14000	37000
50	19000	45000
63	30000	70000
80	50000	110000
100	80000	170000
125	100000	185000

gL type cylindrical fuses

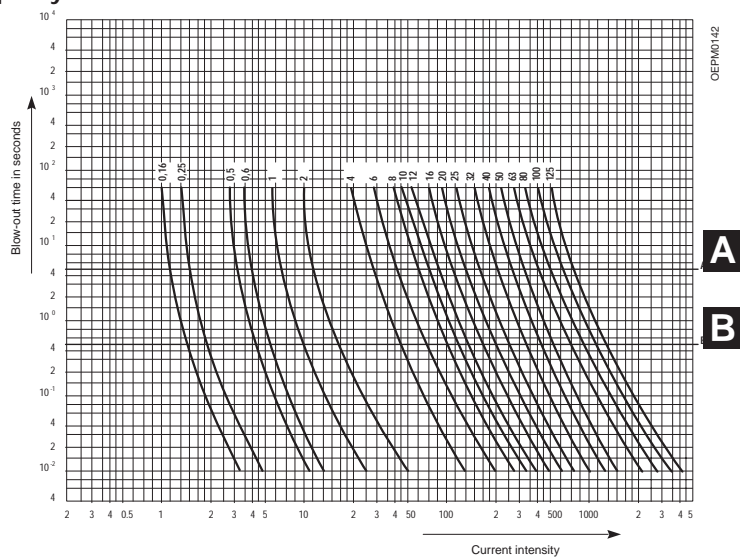

A: max. time for protection against short-circuits
B: max. time for protection against indirect contact for m=1

Type aM cylindrical fuses

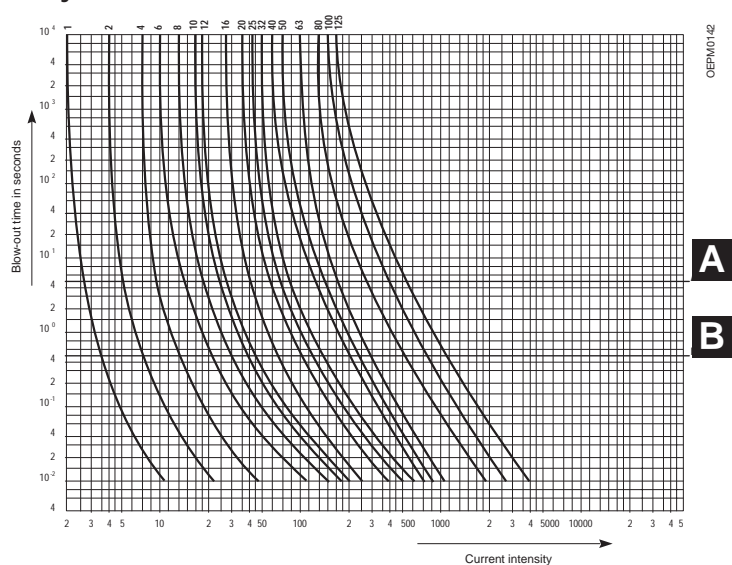

M2160 - M2060 FUSE SWITCHES

Additional technical features

Type	Power consumption [W]	Type	Power consumption [W]	Type	Power consumption [W]	Type	Power consumption [W]
M2161	3.18	M2163	9.54	M2061 Na	4.38	M2063	9.54
M2161 Na	4.38	M2163 Na	16.00	M2062	6.38	M2063 Na	16.00
M2162	6.38	M2061	3.18				

E 259 INSTALLATION RELAYS

Information about lamp insertion between phase and neutral

Incandescent lamps

Power [W]	[Number of lamps]
15	120
25	72
40	45
60	30
75	24
100	18
150	12
200	9
300	6
500	3

Fluorescent lamps without power factor capacitors or serial compensated

Power [W]	[Number of lamps]
15	
18	50
20	45
30	30
36	25
40	23
58	16
65	13

Fluorescent twin-lamps

Power [W]	[Number of lamps]
2x18	50
2x20	45
2x30	30
2x36	25
2x40	23
2x58	16
2x65	13

Fluorescent lamps with power factor capacitors in parallel

Power [W]	[Number of lamps]
18	17
20	17
30	14
36	13
40	12
58	8
65	7

E 250 LATCHING RELAYS

Max. number of lamps, 16 A latching relays

Power [W]	Number of switchable lamps	
	E 250 - 16 A	E 250 - 32 A

Incandescent lamps (230 V AC)

15 W	200	266
25 W	120	160
40 W	75	102
60 W	50	65
75 W	40	52
100 W	30	40
150 W	20	26
200 W	15	20
300 W	9	12
500 W	5	7

Fluorescent lamps without power factor capacitors

18 W	81	110
36 W	44	58
40 W	38	53
58 W	29	35
65 W	26	34

Fluorescent twin-lamps

2x18 W	82	110
2x36 W	41	55
2x40 W	35	50
2x58 W	23	30
2x65 W	22	30

Fluorescent lamps with power factor capacitors in parallel

18 W	103	132
36 W	63	81
40 W	40	77
58 W	41	52
65 W	37	48

230 V halogen lamps (HQL)

150 W	20	27
250 W	12	16
300 W	10	13
400 W	7	10
500 W	6	8
1000 W	3	4

Max. number of lamps, 16 A latching relays

Power [W]	Number of switchable lamps	
	E 250 - 16 A	E 250 - 32 A

High pressure sodium vapor lamps (NAV)

70 W	15	18
150 W	8	10
250 W	4	6
400 W	3	4
1000 W	1	1

Low pressure sodium vapor lamps (SOX)

37 W		
55 W	27	36
56 W		
90 W	16	22
91 W		
135 W	11	14
180 W	8	11
185 W	8	10

High pressure mercury vapor lamps (HQL)

50 W	30	40
80 W	18	25
125 W	12	16
250 W	6	8
400 W	3	5
1000 W	1	2

Lamps with electronic reactor

18 W	83	112
36 W	46	61
58 W	31	38

Very low voltage halogen lamps (12 or 24 V AC)

20 W	116	160
50 W	46	64
75 W	31	42
100 W	24	32
150 W	15	21
200 W	12	16
300 W	7	10

Use of lighted pushbuttons

Latching relays can be controlled through lighted pushbuttons, without any limitations in terms of connection of three-terminal types.

In two-terminals pushbuttons the current that flows through pushbutton lamps can trigger an unwanted activation; in order to avoid this there is the E 250 CP compensation module, installed in parallel on the coil.

Number of E 250 CP compensation modules	Number of connectable lighted pushbuttons	
	1P – 2P types	3P – 4P types
0	8	9
1	18	22
2	45	38

Maximum length of very low voltage connections

Too long feeding cables can reduce voltage so that it is no more enough for guaranteeing standard operating conditions of latching relays, in particular for very low voltage types.

For this reason the wiring must comply with the total lengths (outward and return) shown in the table.

U_N	0.5 mm ²	0.75 mm ²	1 mm ²	1.5 mm ²
8 V~	28 m	41 m	55 m	90 m
12 V~	68 m	102 m	136 m	224 m
24 V~	272 m	412 m	548 m	896 m
48 V~	1096 m	1640 m	2184 m	3584 m

Connection rules (from right to left)

- Far right: motor unit
- On its left the main contacts unit
- On the left side the centralized control unit
- At the end, on the left side, the auxiliary contacts unit

Neither screws nor additional connections are required.

Additional modules or units can be associated with motor units as shown in the table.

Description number	Pole units	Motor units	contact	Main units	control units	Centralized units	auxiliary	Max. module contacts	Total number
		E 251/E 252/ E 256/E 256	E 257 C	E 259	E250 CM	E259 CM	E 257 CM		
		1P 2P	1P 2P 3P	1P 2P			1P		
E 250 latching relays									
Latching									
	1	1						2	2
	2		1					2	2
	3	1			1			1	2 1/2
	4		1		1			1	2 1/2
Maintained control									
	1	1				1		1	2
	2		1			1		1	2
	3	1			1	1		-	2 1/2
	4		1		1	1		-	2 1/2
Same voltage centralized control									
	1			1				2	2
	2				1			1	2
	3					1		1	2 1/2
Different voltage centralized control									
	1	1						1	2 1/2
	2		1					1	2 1/2
	3		1				1	1	2 1/2

E 259 installation relays (contactors)

	1			1				2	2
	2				1			2	2
	3				1	1		1	2 1/2
	4				1	1		1	2 1/2

The 2 exchange contact unit E 259 CM002 can be used only with E259 R001 and E 259 R002 motor units.



LSS1/2 LOAD SHEDDING SWITCH

The LSS1/2 switch intervenes when the total power consumption exceeds the threshold set through the switch placed on the front of the device. After a preset time the switch verifies the possibility to reset disabled not primary loads; the attempt is repeated until a standard situation is established again.

Particularly suitable in applications where load total power is higher than the one indicated in the contract and the average power consumption in a long time interval (dozen minutes) is lower, the LSS1/2 switch can be used in public and industrial single-phase networks and for three-phase networks if they are symmetrical and balanced.

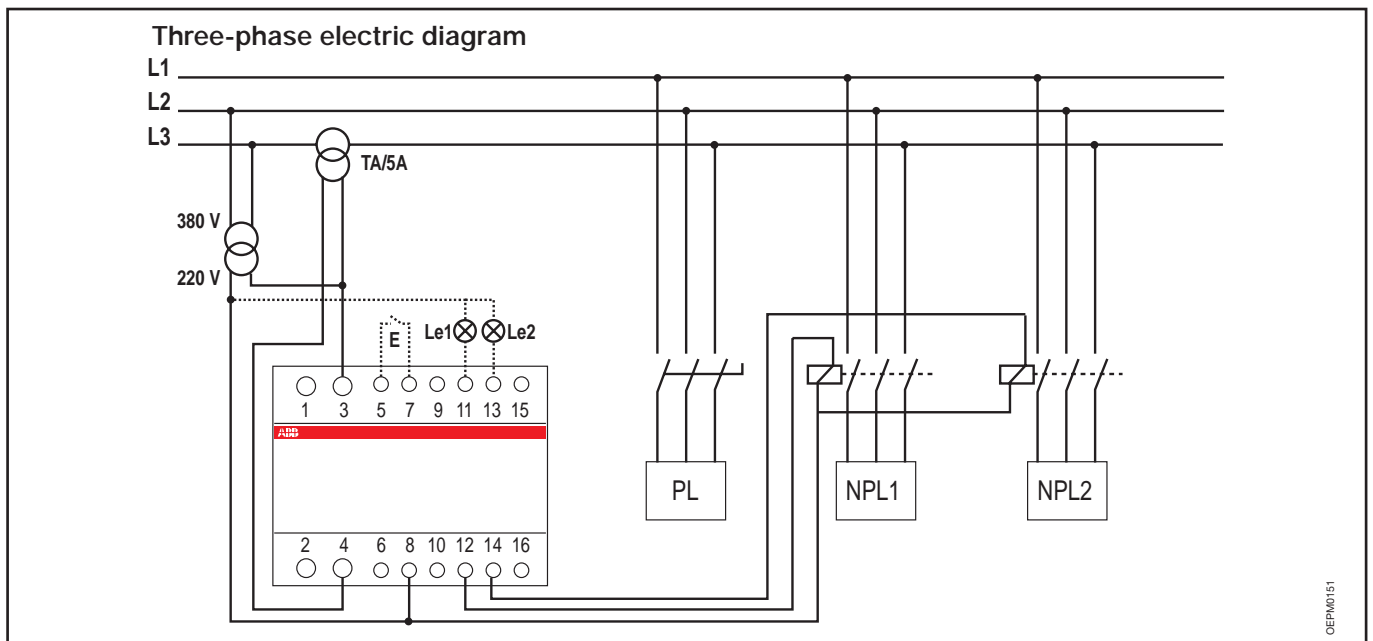
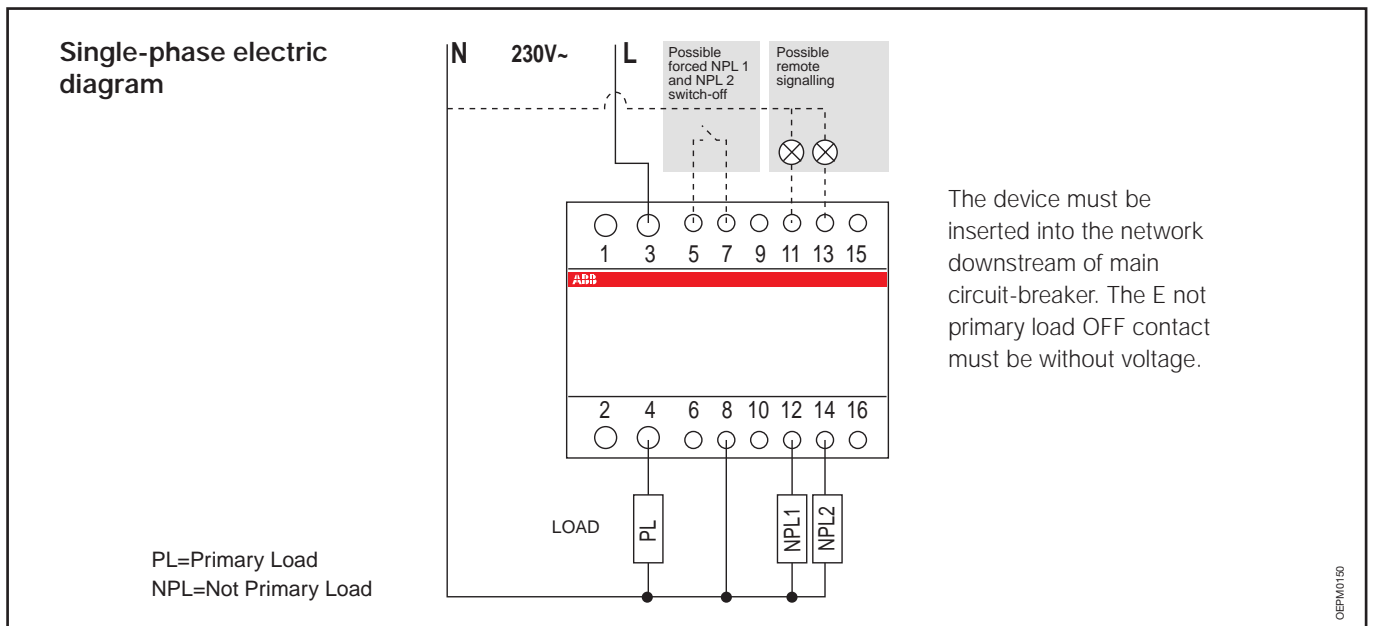

MAX./MIN. CURRENT/VOLTAGE AMMETRIC AND VOLTMETRIC RELAYS

Example of MINIMUM CURRENT relay (RLI) operating principle

Testing a load with the following marking

- $I_n = 7\text{ A}$ (standard operation rated current)
- $V_n = 230\text{ V a.c.}$ (standard operation rated voltage)
- $I_{min} = 6\text{ A}$ (RLI relay intervention)

1. Connect according to the diagram (as $I_{min}=6\text{ A}$).

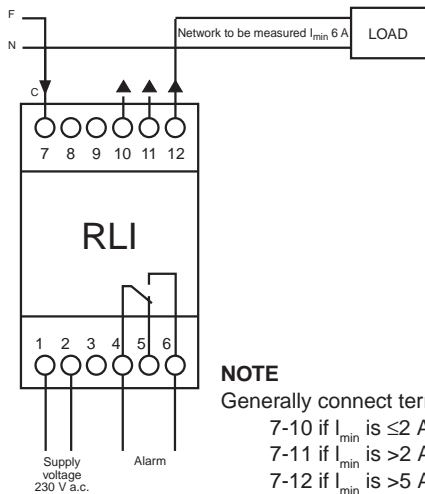

NOTE
Generally connect terminals:
7-10 if I_{min} is $\leq 2\text{ A}$
7-11 if I_{min} is $> 2\text{ A}$ and $\leq 5\text{ A}$
7-12 if I_{min} is $> 5\text{ A}$ and $\leq 10\text{ A}$

2. Set the "Current %" trimmer to 60%, as:

$$I\% = \frac{6 (I_{min})}{10 (I_{set})} \times 100 = 60\%$$

being the terminals 7-12 wired.

3. Set the "Hysteresis %" trimmer; choosing 10% you get an intervention range from 6 to 6.6 A ($6\text{ A} + 10\% = 6.6\text{ A}$).

The relay intervention will be 6 A and the return to the standard operation 6.6 A.

4. Set the "Delay" trimmer. This allows to delay the relay intervention time (1...30 sec).

During the delay the "Power ON" LED blinks; at the end of the delay the "Alarm" LED is permanently lighted and the relay intervenes.

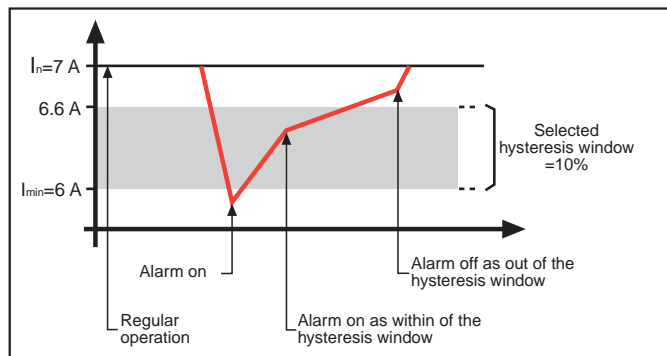

Example of MAXIMUM CURRENT relay (RHI) operating principle

Testing a load with the following marking

- $I_n = 5\text{ A}$ (standard operation rated current)
- $V_n = 230\text{ V a.c.}$ (standard operation rated voltage)
- $I_{max} = 6\text{ A}$ (RHI relay intervention)

1. Connect according to the diagram (as $I_{max}=6\text{ A}$).

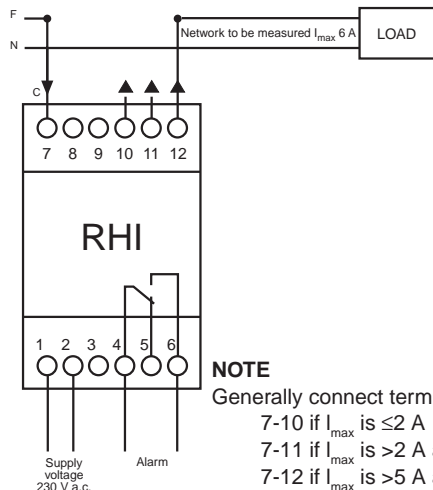

NOTE
Generally connect terminals:
7-10 if I_{max} is $\leq 2\text{ A}$
7-11 if I_{max} is $> 2\text{ A}$ and $\leq 5\text{ A}$
7-12 if I_{max} is $> 5\text{ A}$ and $\leq 10\text{ A}$

2. Set the "Current %" trimmer to 60% as:

$$I\% = \frac{6 (I_{max})}{10 (I_{set})} \times 100 = 60\%$$

being the terminal 7-12 wired.

3. Set the "Hysteresis %" trimmer; choosing 10% you get an intervention range from 5.4 to 6 A ($6\text{ A} - 10\% = 5.4\text{ A}$).

The relay intervention will be 6 A and the return to the standard operation 5.4 A.

4. Set the "Delay" trimmer. This allows to delay the relay intervention time (1...30 sec).

During the delay the "Power ON" LED blinks; at the end of the delay the "Alarm" LED is permanently lighted and the relay intervenes.

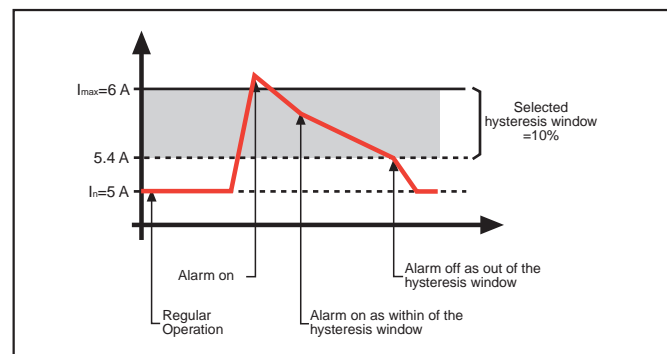

Example of MINIMUM VOLTAGE relay (RLV) operating principle

Managing a load with the following marking

- $I_n = 5 \text{ A}$ (standard operation rated current)
- $V_n = 230 \text{ V a.c.}$ (standard operation rated voltage)
- $V_{min} = 200 \text{ V a.c.}$ (RLV relay intervention)

1. Connect according to the diagram (as $V_{min}=200 \text{ V}$).

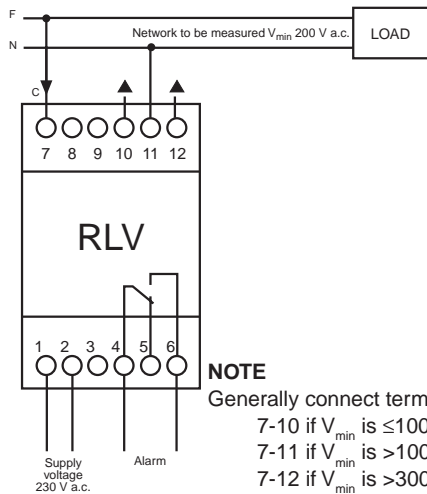

2. Set the "Voltage %" trimmer to 66.7%, as:
$$V\% = \frac{200 (V_{min})}{300 (V_{set})} \times 100 = 66.7\%$$
being the terminal 7-11 wired.
3. Set the "Hysteresis %" trimmer; choosing 10% you get an intervention range from 200 to 220 V ($200+10\%=220 \text{ V}$). The relay intervention will be 200 V and the return to the standard operation 220 V.
4. Set the "Delay" trimmer. This allows to delay the relay intervention time (1...30 sec). During the delay the "Power ON" LED blinks. At the end of the delay the "Alarm" LED is permanently lighted and the relay intervenes.

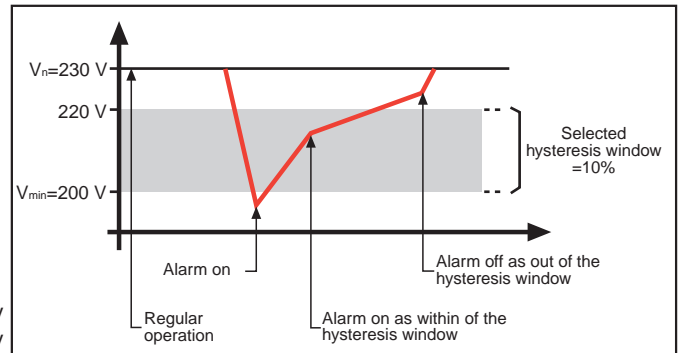

Example of MAXIMUM VOLTAGE relay (RHV) operating principle

Managing a load with the following marking

- $I_n = 5 \text{ A}$ (standard operation rated current)
- $V_n = 230 \text{ V a.c.}$ (standard operation rated voltage)
- $V_{max} = 250 \text{ V a.c.}$ (RHV relay intervention)

1. Connect according to the diagram (as $V_{max}=250 \text{ V}$).

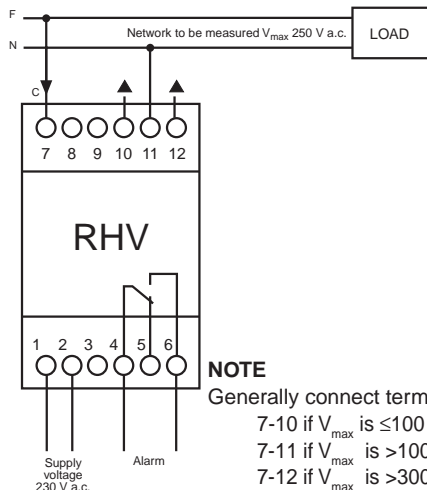

2. Set the "Voltage%" trimmer to 83.33%, as:
$$V\% = \frac{250 (V_{max})}{300 (V_{set})} \times 100 = 83.33\%$$
being the terminal 7-11 wired.
3. Set the "Hysteresis %" trimmer; choosing 5% you get an intervention range from 237.5 to 250 V ($250-5\%=237.5 \text{ V}$). The relay intervention will be 250 V and the return to the standard operation 237.5 V.
4. Set the "Delay" trimmer. This allows to delay the relay intervention time (1...30 sec). During the delay the "Power ON" LED blinks; at the end of the delay the "Alarm" LED is permanently lighted and the relay intervenes.

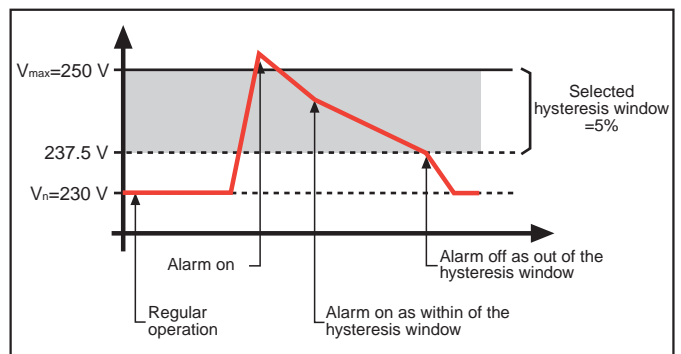



ANALOGUE MEASUREMENT INSTRUMENTS

As regards the insertion of wattmeters and varmeters, they are to be used in combination with the suitable transducers both on single-phase and on three-phase lines.

The following table shows the measurement scale (or full scale) in relation to the voltage and to the current transformers used.

Additional technical features

Test voltage	2000 V for 1' at 50 Hz
Operating temperature	- according to accuracy class: 0 °C ±10 °C - with guaranteed operation but outside accuracy rating: from -25 °C to +75 °C
Resistance to vibrations	±0.25 mm amplitude at 50 Hz
Installation position	- horizontal and vertical - versions for different angles on request
Reading scales	at full scale values according to DIN 43802 Standard
Ammeter power loss	5 A: 0.3 VA; 10 A: 0.6 VA; 25 A: 1 VA; 30 A: 1.2 VA
Voltmeter power loss	300 V: 1.5 VA; 500 V: 4 VA
Frequency meter power loss	<1.5 VA

Wiring diagrams

Power factor meters with alternated current – Single-phase line

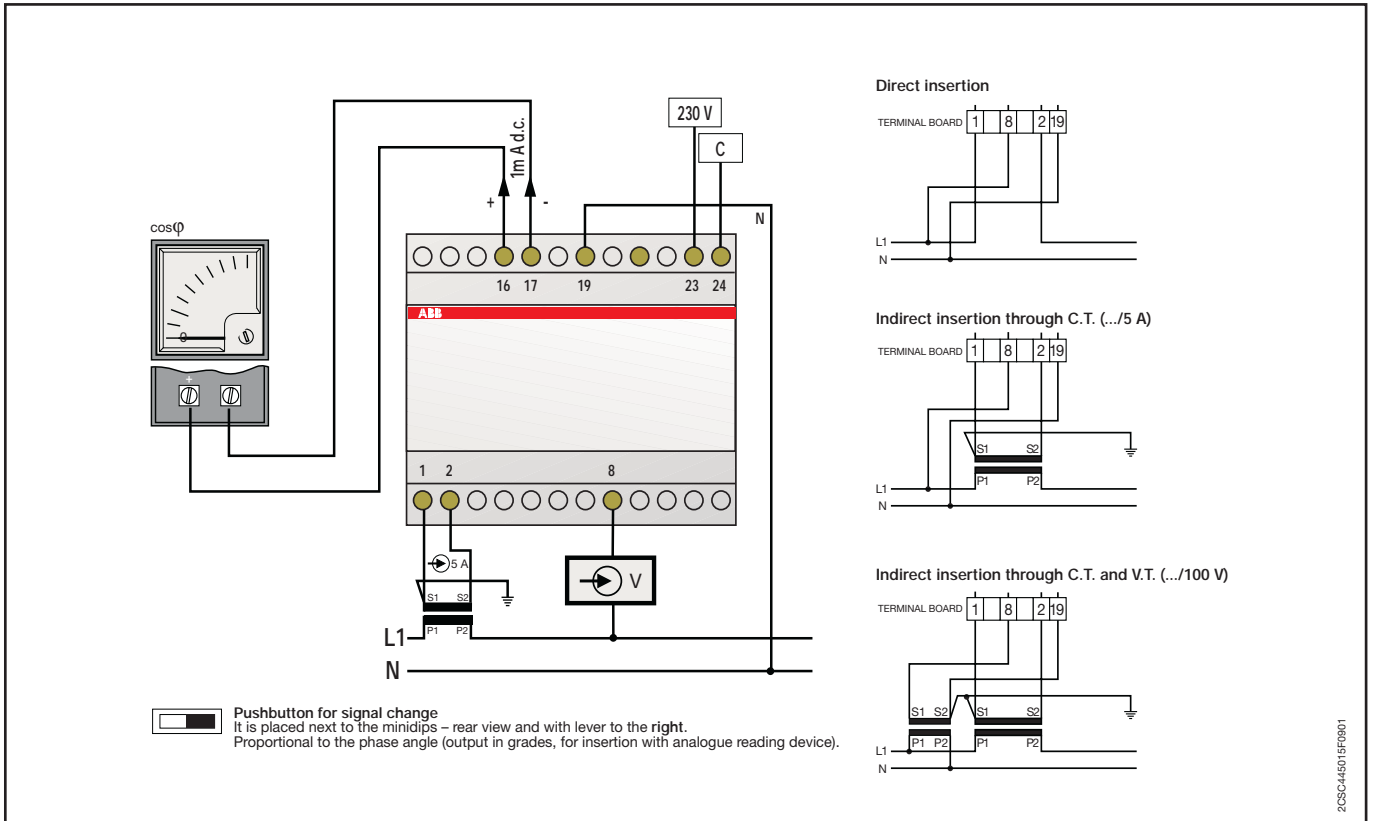

Alternated current power factor meters – Three-phase line without neutral (3 wires)

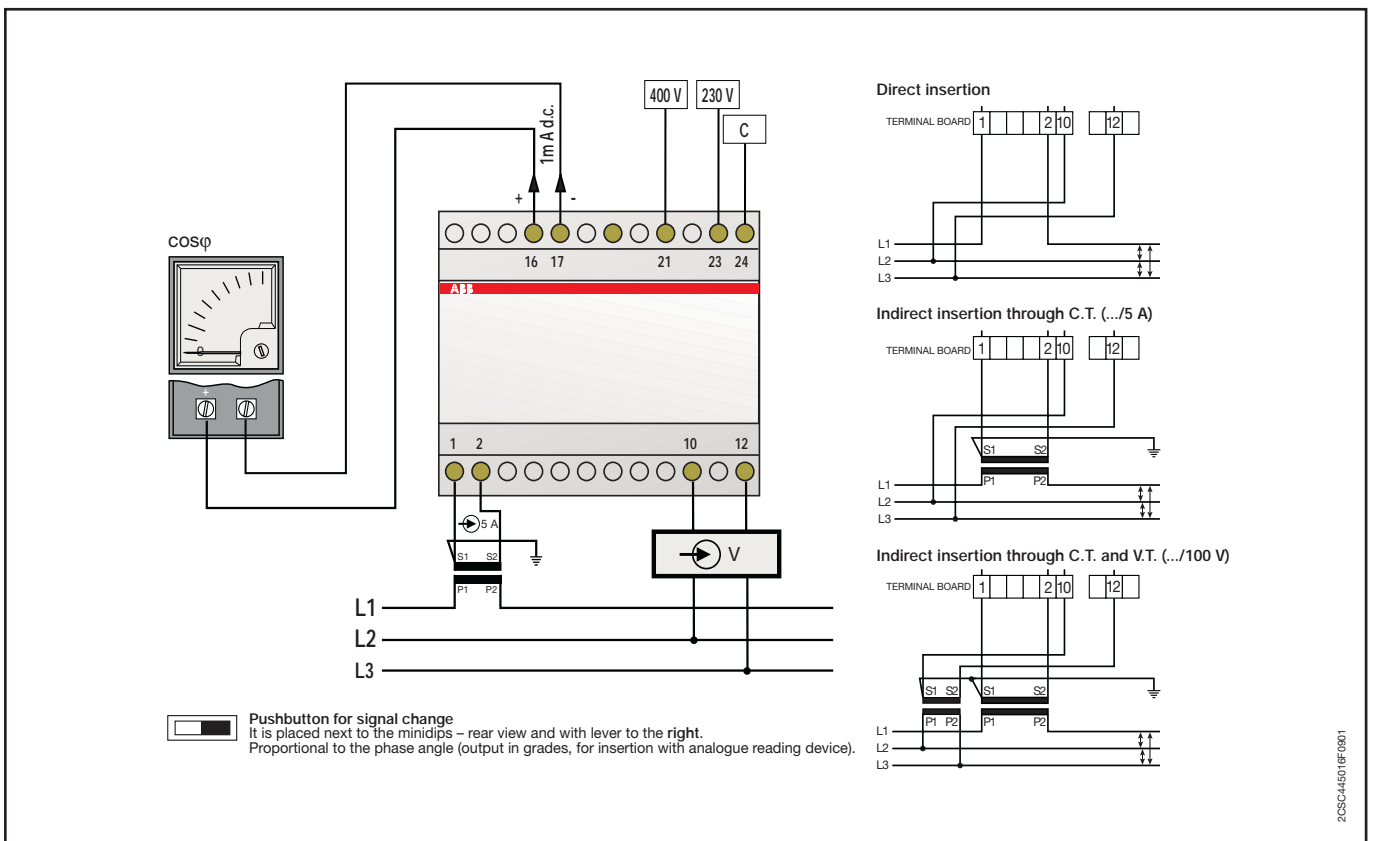

DMTME MULTIMETER

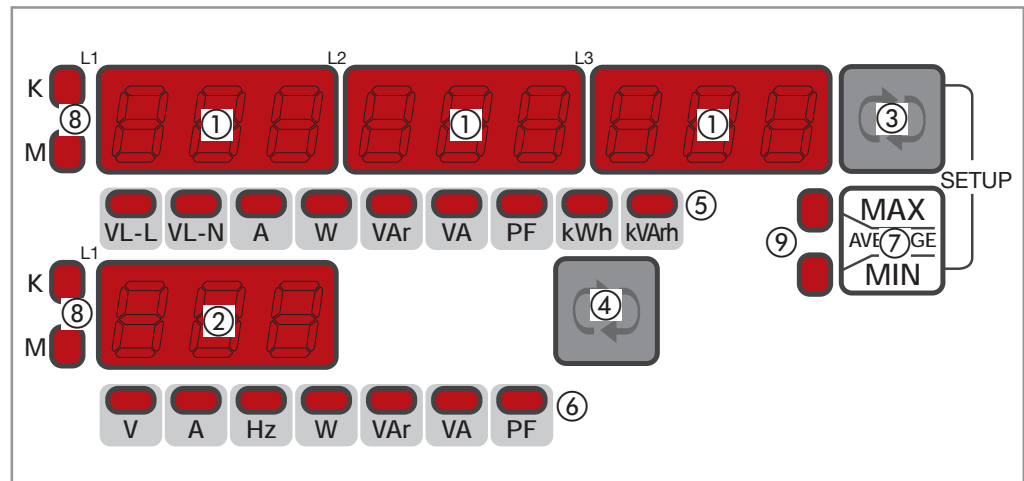



- ① Display L1, L2, L3 for the visualisation of the electrical parameters of every phase, of the energy counters and the time counters. The lighting point, on the right of the third display digits (L3), flashes during RS485 communication (only for DMTME-I-485 model)
- ② 4-th display for the visualisation of the electrical parameters of the three-phase system
- ③ Key for the scan of the electrical parameters for each phase and the energy counters, visualised on the displays L1, L2, L3 (①), if you press-and-hold-down the previous page will be displayed
- ④ Key for the scan of the three-phase electrical parameters, visualised on the 4-th display (②) and the time counters, if you press-and-hold-down the previous page will be displayed
- ⑤ 9 LEDs for the indication of the electrical parameters displayed on the three displays L1, L2, L3 (①)
- ⑥ 7 LEDs for the indication of the electrical parameters displayed on the 4-th display (②)
- ⑦ Key for set out the visualisation of maximum values of the electrical parameters (LED MAX ⑨ switched on), of minimum values (LED MIN ⑩ switched on) and average values (calculation period of 15 minutes) (AVERAGE, simultaneously LED MIN and MAX ⑨ switched on). When the LED, which shows the selected type of visualisation, is switched on, it will be possible to scan in sequence the different electrical parameters by pressing ③ and ④ keys
- ⑧ LED for the identification of the visualised electrical parameters scale on both instrument's displays ① and ② (factor K = kilo, parameter x 1.000 and factor M = mega, parameter x 1.000.000)
- ⑨ LED for the identification of the max/min/average values displayed on the displays ① and ②
- ③ + ⑦ Press together allow the access to the configuration menu (setup)



Measured parameters

Phase-to-phase voltage (VL-L)	VL1-L2, VL2-L3, VL3-L1
Line and three-phase voltage (VL-N and ΣV)	VL1-N, VL2-N, VL3-N, ΣV
Line and three-phase current (A and ΣA)	I1, I2, I3, ΣI
Frequency	Hz
Line and three-phase active power (W and ΣW)	W1, W2, W3, ΣW
Line and three-phase reactive power (VAr and ΣVAr)	VAr1, VAr2, VAr3, ΣVAr
Line and three-phase apparent power (VA and ΣVA)	VA1, VA2, VA3, ΣVA
Line and three-phase power-factor/cosj, with indication of the conventional sign (+ = inductive load, - = capacitive load)	PF1, PF2, PF3, ΣPF

CURRENT TRANSFORMERS

Standard type

TYPE		CT-3	CT-4	CT-5	CT-6	CT-8	CT-12	CT-8V	CT-12V
OPERATION		Through primary							
CENTRAL SECTION	 HORIZ. BAR	20x10 30x10	30x10	30x30 40x25 - 50x20	50x20 60x20	60x30 80x30	80x50 100x50 125x50		
	 CABLE	21	25	30	50	2x30	2x50	2x35	3x35
	 VERT. BAR	20x10	30x10	30x10				min. 80x30 + max. 3x80x5	min. 100x10 + max. 4x125x5
Primary current (A)	Power (VA)	Power (VA)		Power (VA)		Power (VA)		Power (VA)	Power (VA)
	Rating	Rating	Rating	Rating	Rating	Rating	Rating	Rating	Rating
	0.5 1 3	0.2 0.5 0.2S	0.5 1 0.2S	0.2 0.5	0.5 1 0.2S	0.5 1 0.2S	0.5 1 0.2S	0.5 1 0.2S	0.5 1 0.2S
1									
5									
10									
15									
20									
25									
30									
40			2						
50			2						
60			2						
80			3						
100		3		3					
150	3		4	5	3				
200	3		4	6	3	4			
250	5		5	10	3	3			5
300	5		5	10		4			5
400	6			10		6		5	6
500	6			10		10	5	5	6
600	6			10		10	5	5	10
800						10	5	10	10
1000						10		5	20
1200						10			20
1500						20			30
2000									30
2500									30
3000									20
4000									20
DIMENSIONS	Height	75	87	100	110	120	175	119	165
	Width	58	75	85	105	125	180	109	109
	Depth	44	44	45	61	61.5	68.5	41	41

Compact type						Miniaturized type									
TYPE	CT-M1	CT-M3	CT-M4	CT-M5	CT-M6	CT-SM1	CT-SM2	CT-SM3	CT-SM4	CT-SM5	CT-SM6	CT-SM7	CT-SM8	CT-SM9	
OPERATION	Through primary					Through primary									
CENTRAL SECTION			20x12 25x15 30x10	25x25 30x20 40x10	50x12	50x23 63x20		15x5			min 25x5 max 25x6,5		min. 29x5 max. 2x32x5	min. 30x5 max. 2x63x5	
		21	23	30		2x22	13	11	18	25		32			
				25x25 30x20 40x10							15x5 20x5		32x5	50x5 2x50x5 2x50x10 3x50x5	2x63x5 3x63x5
Primary current (A)	Power (VA)	Power (VA)	Power (VA)	Power (VA)	Power (VA)	Power (VA)	Power (VA)	Power (VA)	Power (VA)	Power (VA)	Power (VA)	Power (VA)	Power (VA)	Power (VA)	
	Rating 0.5 1 3	Rating 0.5 1	Rating 0.5 1	Rating 0.5 1	Rating 0.5	Rating 1 3	Rating 1 3	Rating 0.5 1 3	Rating 0.5	Rating 0.5 1	Rating 0.5	Rating 0.5 1	Rating 0.5 1	Rating 0.5 1	
40						2									
50						2									
60						2									
75															
80															
100	3		2		3										
120															
125															
150		4		3											
200	3		3	4						5				5	
250	3		2	6		3				10			5	5	
300			2	6		4				10			5	5	
400			3	10		4				10			6	6	
500				10		6							10	10	
600				10		6							10	10	
800				10		10							10	10	
1000				10		10							15	15	
1200						15									
1250													15	15	
1500						20							15		
2000															
2500															
3000															
4000															
DIMENSIONS	Height	65	65	81,5	81,5	106	58	58	90,5	90,5	72	90,5	90,5	116	119
	Width	52	52	70	70	101	34,5	34,5	56	56	44	56	56	87	70
	Depth	27	27	44	44	44	53,3	53,3	53,3	53,3	53,3	53,3	53,3	53,3	53,3
Min. distance betw. centers						27	27	45	45	35	45	45	45-35	70-50	45

Self-consumption of copper cables between the device and the transformer

For 5 A secondary

Cable section mm ²	Power (two-pole cable) VA VA					
	Distance					
	1 m	2 m	4 m	6 m	8 m	10 m
1.5	0.58	1.15	2.31	3.46	4.62	5.77
2.5	0.36	0.71	1.43	2.14	2.86	3.57
4	0.22	0.45	0.89	1.34	1.79	2.24
6	0.15	0.30	0.60	1.89	1.19	1.49
10	0.09	0.18	0.36	0.54	0.71	0.89

For 1A secondary

Cable section mm ²	Power (two-pole cable) VA VA					
	Distance					
	10 m	20 m	40 m	60 m	80 m	100 m
1	0.36	0.71	1.43	2.14	2.85	3.57
1.5	0.23	0.46	0.92	1.39	1.85	2.31
2.5	0.14	0.29	0.57	0.86	1.14	1.43
4	0.09	0.18	0.36	0.54	0.71	0.89
6	0.06	0.12	0.24	0.36	0.48	0.60
10	0.04	0.07	0.14	0.21	0.29	0.36

Maximum load (A) on copper bars according
to DIN 43670 and 43671

Bar dimensions mm	Rated current (In) A		
	1 bar	2 bars	3 bars
20x5	325	560	
20x10	427	925	1180
30x5	379	672	896
30x10	573	1060	1480
40x5	482	836	1090
40x10	715	1290	1770
50x10	852	1510	2040
60x10	985	1720	2300
80x10	1240	2110	2790
100x10	1490	2480	3260

Rating	Ratio fault limit in %			
	0.05 In	0.2 In	In	1.2 In
0.5	±1	±0.75	±0.5	±0.5
1	±2	±1.5	±1	±1
3	From 0.5 In to 1.2 In = ±3			

Rating	Angle fault limit in %			
	0.05 In	0.2 In	In	1.2 In
0.5	±1.8	±1.35	±0.9	±0.9
1	±3.6	±2.7	±1.8	±1.8
3	No prescriptions			

Accuracy rating

- 0.5 rating is required for power meters.
- 1 rating is required for unofficial power measures and power meters (measurements within the firm).
- 3 rating is required for relays and protection devices.

According to DIN 185, VDE-0414 and UNIE-21028 current and angle fault limits shall comply with the value shown in the table.

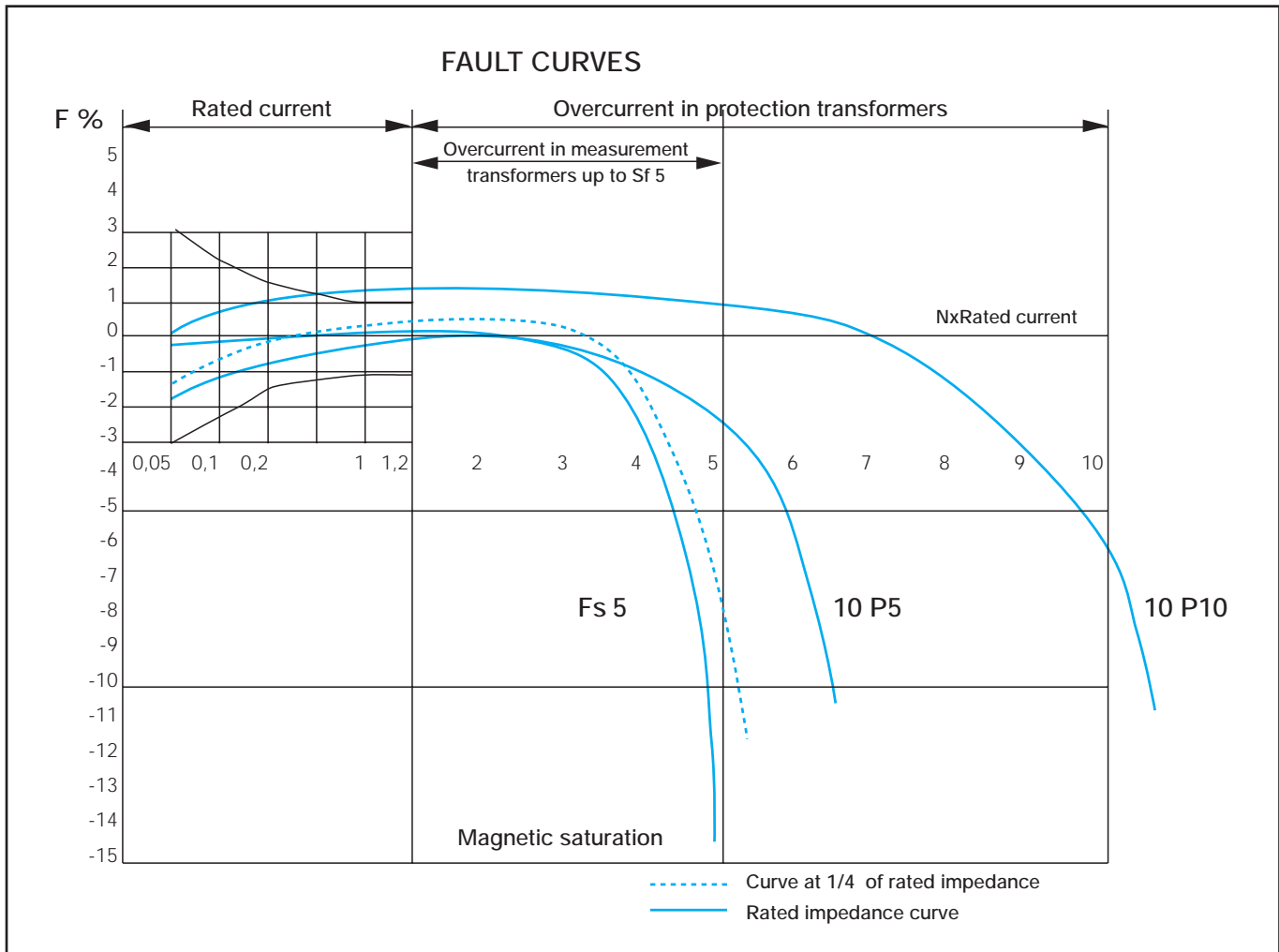

Cable diameter calculation

The following formula applies for determining the diameters of a 95 mm² cable:

- section = $r \times r \times 3.14$ that is $r^2 \times 3.14$ from which $r = \sqrt{\text{section} / 3.14}$ $r = \sqrt{95 / 3.14} = 30.25 = 5.5$ mm, so the radius is 5.5 mm
- diameter = $r + r$ so the diameter is $5.5 + 5.5$ mm = 11 mm (copper diameter to be added to the insulating material thickness, total \varnothing about 20 mm).

With many insertion of the cable into the current transformer it is possible to halve the primary current while performance and rating values remain unaltered.

Example

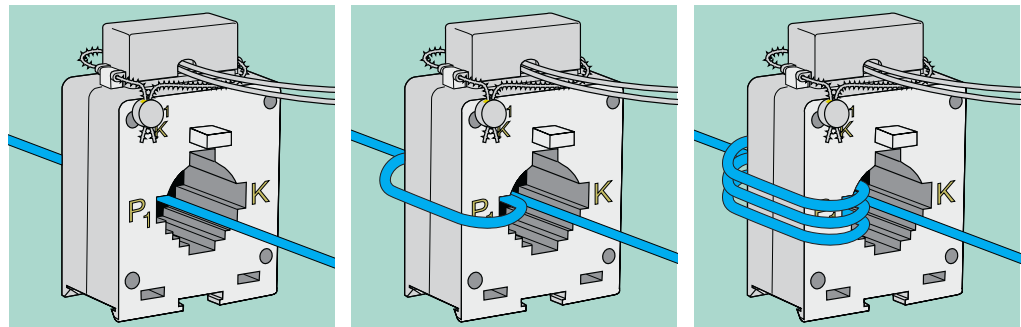



SUMMING CURRENT TRANSFORMERS

The examples shown in the drawings refer to the connection to an ammetric phase. For the connection to two systems (ARON) it is necessary to use two summing transformers and two ammetric transformers (respectively for phase L1 and for phase L3). For the connection to three systems it is necessary to use two summing transformers and three ammetric transformers (respectively for phase L1, for phase L2 and for phase L3).

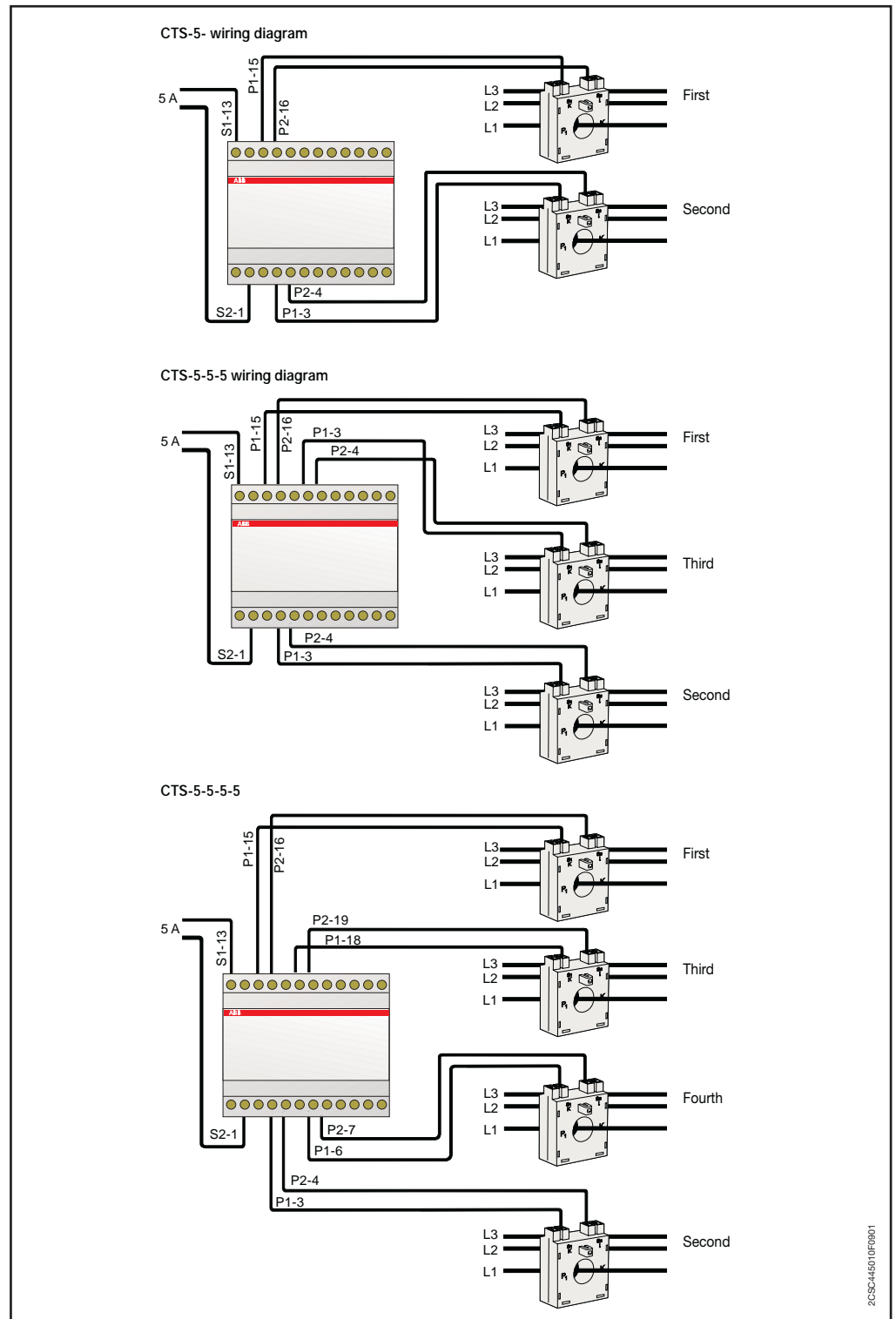

CURRENT AND VOLTAGE CONVERTERS

Technical characteristics

		Ammetric converters	Voltmetric converters
		in a.c./d.c.	in a.c./d.c.
Auxiliary supply (separated)	[V]	a.c. 230	a.c. 230
Input rated values		1-5 A	120-300-500 V
Output rated values	[V d.c.]	1-5-10	1-5-10
	[mA d.c.]	1-5-10-4...20	1-5-10-4...20
Ohmic load	[Ω]	700	700
Measurement field		0±In	0±Un
Accuracy rating		0.5	0.5
Overload			
Permanent		2 In	2 Un
Instantaneous		10 In/1 sec.	10 Un/1 sec.
Frequency	[Hz]	50/60	50/60
Time delay	[ms]	≤300	≤300
Alternated residue		≤1%	≤1%
Self-consumption		current ≤0,8 VA aux. supply ≤4 VA	voltage ≤1 VA aux. supply ≤4 VA
Input/output galvanic separation			
Input/output insulation, aux. supply		2 kV/50 Hz -1 min	2 kV/50 Hz -1 min
Circuit/mass insulation		4 kV/50 Hz -1 min	4 kV/50 Hz -1 min
Operating temperature	[°C]	0...+55	0...+55
Dimensions		3-6 DIN modules	3-6 DIN modules
Weight	[kg]	0.30	0.30

Current converters (a.c. input)

Output selection terminals: 7, 8, 9, 10, 11, 12. Output values: 10 V d.c., 5 V d.c., 1 V d.c., 4-20 mA d.c., 20 mA d.c., 10 mA d.c., 5 mA d.c., 1 mA d.c.

Input selection terminals: 1, 2, 3, 4, 5, 6. Input values: 1 A MAX, 5 A MAX, common 'C' (n. 6).

The output selection must be performed by moving the programming pushbuttons according to the specific needs.

If a V output has been selected it is necessary to connect terminals 7 and 8, while for mA outputs the terminals 11 and 12 must be connected.

The input selection is performed by connecting the terminal of the common "C" (n. 6) to the terminal 4, for a 1 A input, and to the terminal 5 for a 5 A input.

SELECTABLE OUTPUTS

	1	2	3	4	5	6	1	2	3	4	5	6	1	2	3	4	5	6	1	2	3	4	5	6
1 mA	□	□	□	□	□	□	□	□	□	□	□	□	□	□	□	□	□	□	□	□	□	□	□	□
	■	■	■	■	■	■	■	■	■	■	■	■	■	■	■	■	■	■	■	■	■	■	■	■
						OFF						OFF						OFF						OFF
						ON						ON						ON						ON
5 mA	□	□	□	□	□	□	□	□	□	□	□	□	□	□	□	□	□	□	□	□	□	□	□	□
	■	■	■	■	■	■	■	■	■	■	■	■	■	■	■	■	■	■	■	■	■	■	■	■
						OFF						OFF						OFF						OFF
						ON						ON						ON						ON
10 mA	□	□	□	□	□	□	□	□	□	□	□	□	□	□	□	□	□	□	□	□	□	□	□	□
	■	■	■	■	■	■	■	■	■	■	■	■	■	■	■	■	■	■	■	■	■	■	■	■
						OFF						OFF						OFF						OFF
						ON						ON						ON						ON
20 mA	□	□	□	□	□	□	□	□	□	□	□	□	□	□	□	□	□	□	□	□	□	□	□	□
	■	■	■	■	■	■	■	■	■	■	■	■	■	■	■	■	■	■	■	■	■	■	■	■
						OFF						OFF						OFF						OFF
						ON						ON						ON						ON

Current converters (d.c. input)

The output selection must be performed by moving the programming pushbuttons according to the specific needs.

SELECTABLE OUTPUTS																			
	1	2	3	4	5	6	1	2	3	4	5	6							
1 mA	<input type="checkbox"/>	<input type="checkbox"/>	<input type="checkbox"/>	<input type="checkbox"/>	<input type="checkbox"/>	<input type="checkbox"/>	<input type="checkbox"/>	<input type="checkbox"/>	<input type="checkbox"/>	<input type="checkbox"/>	<input type="checkbox"/>	<input type="checkbox"/>	OFF	<input type="checkbox"/>	<input type="checkbox"/>	<input type="checkbox"/>	<input type="checkbox"/>	OFF	1 V
	<input checked="" type="checkbox"/>						<input checked="" type="checkbox"/>						ON	<input checked="" type="checkbox"/>	<input checked="" type="checkbox"/>	<input checked="" type="checkbox"/>	<input checked="" type="checkbox"/>	ON	
5 mA	<input type="checkbox"/>	<input type="checkbox"/>	<input type="checkbox"/>	<input type="checkbox"/>	<input type="checkbox"/>	<input type="checkbox"/>	<input type="checkbox"/>	<input type="checkbox"/>	<input type="checkbox"/>	<input type="checkbox"/>	<input type="checkbox"/>	<input type="checkbox"/>	OFF	<input type="checkbox"/>	<input type="checkbox"/>	<input type="checkbox"/>	<input type="checkbox"/>	OFF	5 V
	<input checked="" type="checkbox"/>						<input checked="" type="checkbox"/>						ON	<input checked="" type="checkbox"/>	<input checked="" type="checkbox"/>	<input checked="" type="checkbox"/>	<input checked="" type="checkbox"/>	ON	
10 mA	<input type="checkbox"/>	<input type="checkbox"/>	<input type="checkbox"/>	<input type="checkbox"/>	<input type="checkbox"/>	<input type="checkbox"/>	<input type="checkbox"/>	<input type="checkbox"/>	<input type="checkbox"/>	<input type="checkbox"/>	<input type="checkbox"/>	<input type="checkbox"/>	OFF	<input type="checkbox"/>	<input type="checkbox"/>	<input type="checkbox"/>	<input type="checkbox"/>	OFF	10 V
	<input checked="" type="checkbox"/>						<input checked="" type="checkbox"/>						ON	<input checked="" type="checkbox"/>	<input checked="" type="checkbox"/>	<input checked="" type="checkbox"/>	<input checked="" type="checkbox"/>	ON	
20 mA	<input type="checkbox"/>	<input type="checkbox"/>	<input type="checkbox"/>	<input type="checkbox"/>	<input type="checkbox"/>	<input type="checkbox"/>	<input type="checkbox"/>	<input type="checkbox"/>	<input type="checkbox"/>	<input type="checkbox"/>	<input type="checkbox"/>	<input type="checkbox"/>	OFF	<input type="checkbox"/>	<input type="checkbox"/>	<input type="checkbox"/>	<input type="checkbox"/>	OFF	4-20 mA
	<input checked="" type="checkbox"/>						<input checked="" type="checkbox"/>						ON	<input checked="" type="checkbox"/>	<input checked="" type="checkbox"/>	<input checked="" type="checkbox"/>	<input checked="" type="checkbox"/>	ON	

Voltage converters (a.c. input)

The output selection must be performed by moving the programming pushbuttons according to the specific needs.

SELECTABLE OUTPUTS																			
	1	2	3	4	5	6	1	2	3	4	5	6							
1 mA	<input type="checkbox"/>	<input type="checkbox"/>	<input type="checkbox"/>	<input type="checkbox"/>	<input type="checkbox"/>	<input type="checkbox"/>	<input type="checkbox"/>	<input type="checkbox"/>	<input type="checkbox"/>	<input type="checkbox"/>	<input type="checkbox"/>	<input type="checkbox"/>	OFF	<input type="checkbox"/>	<input type="checkbox"/>	<input type="checkbox"/>	<input type="checkbox"/>	OFF	1 V
	<input checked="" type="checkbox"/>						<input checked="" type="checkbox"/>						ON	<input checked="" type="checkbox"/>	<input checked="" type="checkbox"/>	<input checked="" type="checkbox"/>	<input checked="" type="checkbox"/>	ON	
5 mA	<input type="checkbox"/>	<input type="checkbox"/>	<input type="checkbox"/>	<input type="checkbox"/>	<input type="checkbox"/>	<input type="checkbox"/>	<input type="checkbox"/>	<input type="checkbox"/>	<input type="checkbox"/>	<input type="checkbox"/>	<input type="checkbox"/>	<input type="checkbox"/>	OFF	<input type="checkbox"/>	<input type="checkbox"/>	<input type="checkbox"/>	<input type="checkbox"/>	OFF	5 V
	<input checked="" type="checkbox"/>						<input checked="" type="checkbox"/>						ON	<input checked="" type="checkbox"/>	<input checked="" type="checkbox"/>	<input checked="" type="checkbox"/>	<input checked="" type="checkbox"/>	ON	
10 mA	<input type="checkbox"/>	<input type="checkbox"/>	<input type="checkbox"/>	<input type="checkbox"/>	<input type="checkbox"/>	<input type="checkbox"/>	<input type="checkbox"/>	<input type="checkbox"/>	<input type="checkbox"/>	<input type="checkbox"/>	<input type="checkbox"/>	<input type="checkbox"/>	OFF	<input type="checkbox"/>	<input type="checkbox"/>	<input type="checkbox"/>	<input type="checkbox"/>	OFF	10 V
	<input checked="" type="checkbox"/>						<input checked="" type="checkbox"/>						ON	<input checked="" type="checkbox"/>	<input checked="" type="checkbox"/>	<input checked="" type="checkbox"/>	<input checked="" type="checkbox"/>	ON	
20 mA	<input type="checkbox"/>	<input type="checkbox"/>	<input type="checkbox"/>	<input type="checkbox"/>	<input type="checkbox"/>	<input type="checkbox"/>	<input type="checkbox"/>	<input type="checkbox"/>	<input type="checkbox"/>	<input type="checkbox"/>	<input type="checkbox"/>	<input type="checkbox"/>	OFF	<input type="checkbox"/>	<input type="checkbox"/>	<input type="checkbox"/>	<input type="checkbox"/>	OFF	4-20 mA
	<input checked="" type="checkbox"/>						<input checked="" type="checkbox"/>						ON	<input checked="" type="checkbox"/>	<input checked="" type="checkbox"/>	<input checked="" type="checkbox"/>	<input checked="" type="checkbox"/>	ON	

If a V output has been selected it is necessary to connect terminals 7 and 8, while for mA outputs the terminals 11 and 12 must be connected.

The input selection is performed by connecting the terminal of the common "C" (6) to the terminal 5, for a 120 V input, or to the terminal 4 for a 300 V input or to the terminal 3 for a 500 V input.

Voltage converters (d.c. input)

The output selection must be performed by moving the programming pushbuttons according to the specific needs.

		SELECTABLE OUTPUTS																	
		1 2 3 4 5 6			1 2 3 4 5 6			1 2 3 4 5 6			1 2 3 4 5 6								
1 mA	1 V	■	■	■	■	■	■	■	■	■	■	■	■	■	■	■	■	OFF	ON
5 mA	5 V	■	■	■	■	■	■	■	■	■	■	■	■	■	■	■	■	OFF	ON
10 mA	10 V	■	■	■	■	■	■	■	■	■	■	■	■	■	■	■	■	OFF	ON
20 mA	4-20 mA	■	■	■	■	■	■	■	■	■	■	■	■	■	■	■	■	OFF	ON

INPUT SIGNAL SELECTION

■ ■ ■ ■	OFF	■ ■ ■ ■	OFF	■ ■ ■ ■	OFF
■ ■ ■ ■	ON	■ ■ ■ ■	ON	■ ■ ■ ■	ON
120 V		300 V		500 V	

The cables of the selected inputs must be connected to terminals 4 and 6.



TRANSDUCERS FOR POWER FACTOR METERS

Technical characteristics

Separated auxiliary supply	[V]	a.c. 230/400
Input rated values	[V]	a.c. 230/400 (5 A)
Output rated values (selectable)		1, 5, 10 V d.c. 1, 5, 10, 20, 4/20 mA d.c.
Ohmic load	[Ohm]	700
Measurement field		0÷Pn (0÷Qn)
Conversion type		proportional to phase angle or to cosφ
Accuracy rating		0.5
Permanent overload		2 In/1.2 Un
Instantaneous overload		10 In/2 Un for 1 sec.
Operating frequency	[Hz]	50/60
Time delay	[ms]	300
Alternated residue		1%
Self-consumption		voltage=1 VA/curr.=0.8 VA/aux. supply=4 VA
Input/output galvanic separation		input/output insulation, aux. supply 2 kV for 1 min./50 Hz circuit/mass insulation 4 kV for 1 min./50 Hz
Operating temperature	[°C]	0...55
Dimensions		6 DIN modules
Weight	[kg]	0.49

Single-phase line and input and output selection

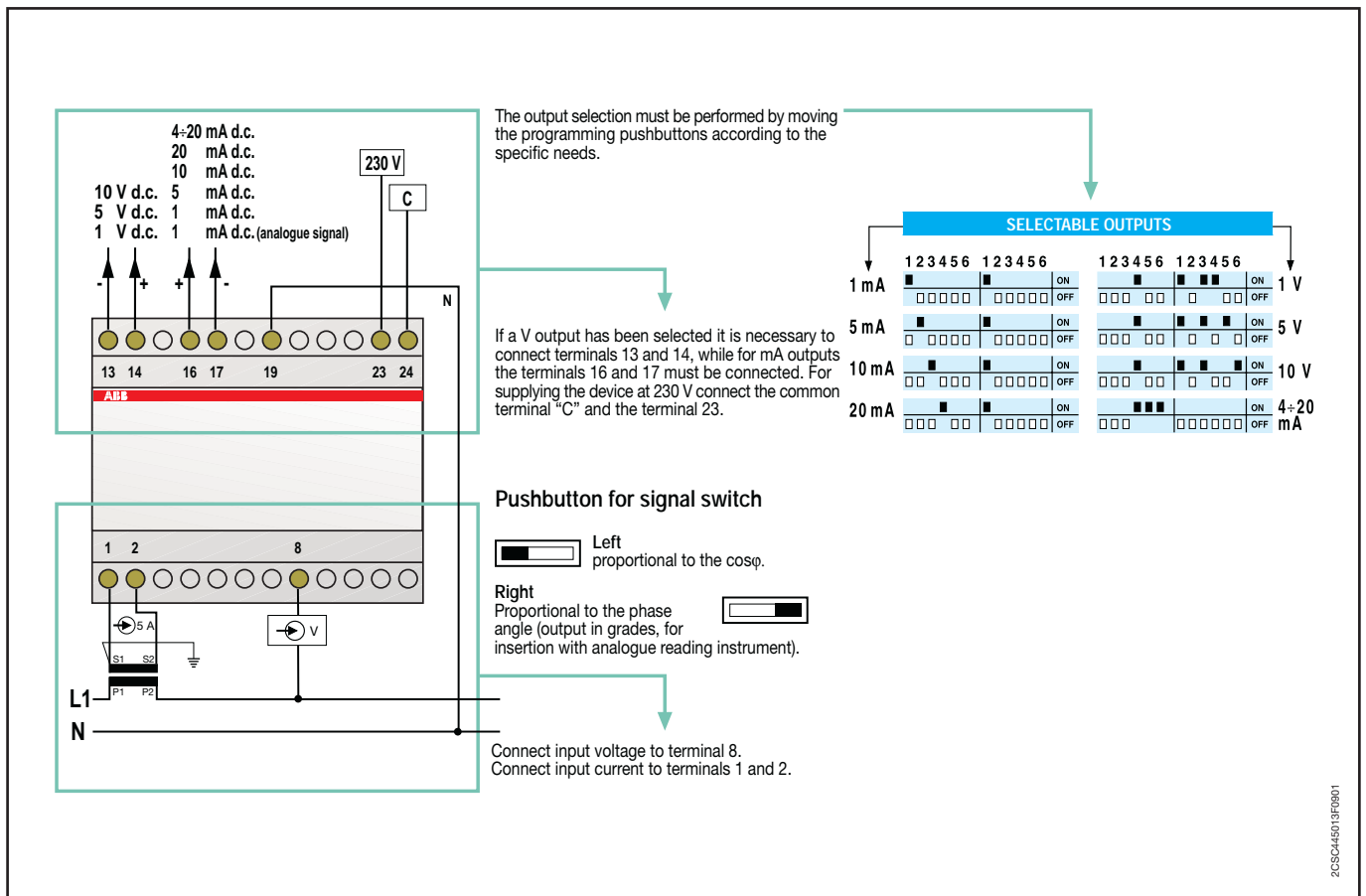

Balanced three-phase line without neutral (3 wires)

The output selection must be performed by moving the programming pushbuttons according to the specific needs.

If a V output has been selected it is necessary to connect terminals 13 and 14, while for mA outputs the terminals 16 and 17 must be connected. For supplying the device at 230 V connect the common terminal "C" and the terminal 23, while for a 400 V supply it is necessary to connect the common terminal "C" and the terminal 21.

Pushbutton for signal switch

Left
Proportional to the $\cos\phi$.

Right
Proportional to the phase angle (output in grades, for insertion with analogue reading instrument).

Connect input voltage to terminals 10 and 12.
Connect input current of L1 phase to terminals 1 and 2.

SELECTABLE OUTPUTS

Output	1	2	3	4	5	6	1	2	3	4	5	6	1	2	3	4	5	6	
1 mA	■	□	□	□	□	□	■	□	□	□	□	□	■	□	□	□	□	□	OFF
5 mA	■	□	□	□	□	□	■	□	□	□	□	□	■	□	□	□	□	□	OFF
10 mA	■	□	□	□	□	□	■	□	□	□	□	□	■	□	□	□	□	□	OFF
20 mA	■	□	□	□	□	□	■	□	□	□	□	□	■	□	□	□	□	□	OFF
1 V	■	□	□	□	□	□	■	□	□	□	□	□	■	□	□	□	□	□	OFF
5 V	■	□	□	□	□	□	■	□	□	□	□	□	■	□	□	□	□	□	OFF
10 V	■	□	□	□	□	□	■	□	□	□	□	□	■	□	□	□	□	□	OFF
4-20 mA	■	□	□	□	□	□	■	□	□	□	□	□	■	□	□	□	□	□	OFF

2GSC446014F0901

INSULATION CONTROL DEVICES

Wiring diagrams

The following schemes illustrate the Isoltester-DIG-RZ and Isoltester-DIG-PLUS wiring diagrams with the QSD-DIG remote control panel in single- and three-phase networks, with or without central socket, and the Selvtester wiring diagrams with QSD 230/24 remote control panel.

Wiring diagram with transformer with central socket (PC)

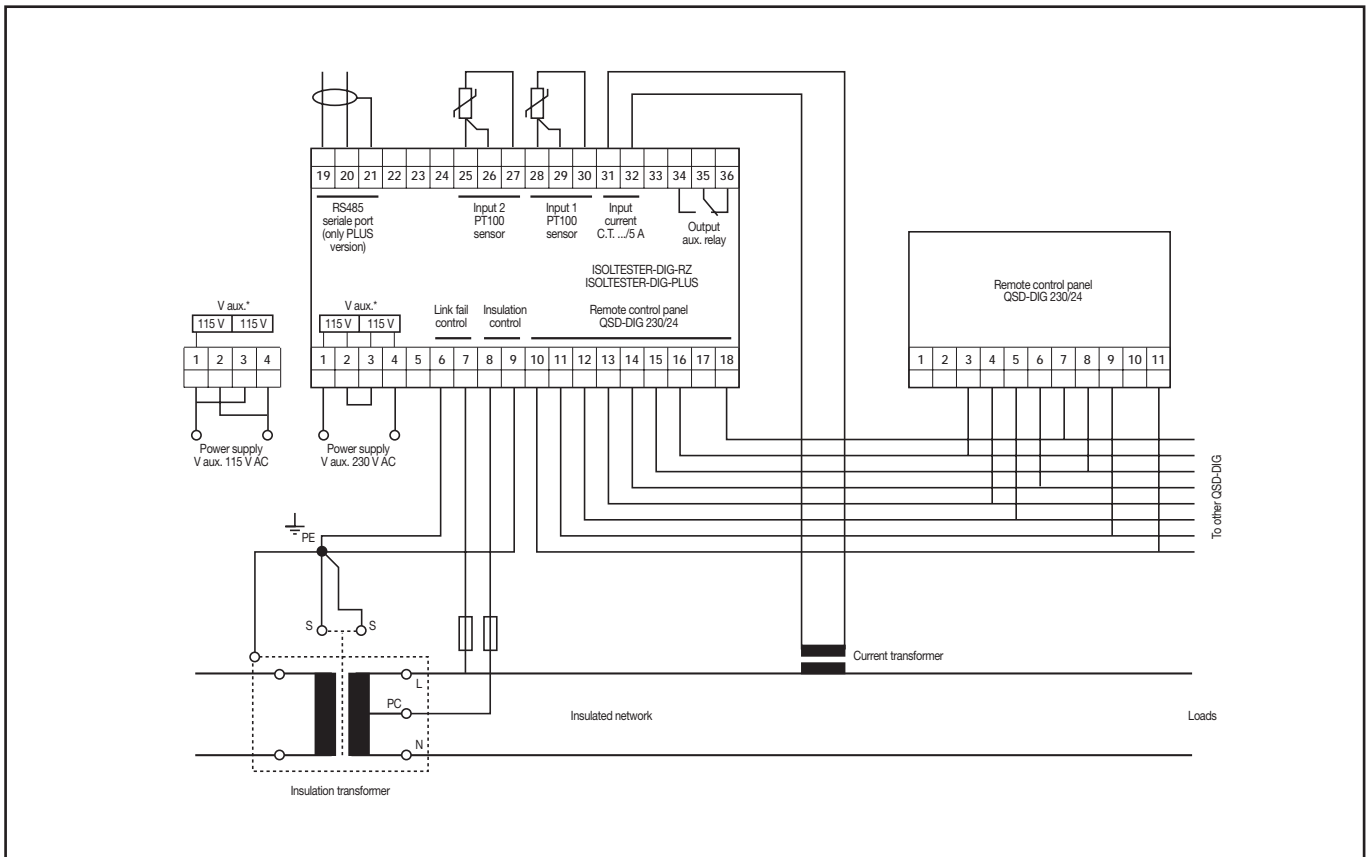

Wiring diagram with transformer without central socket (PC)

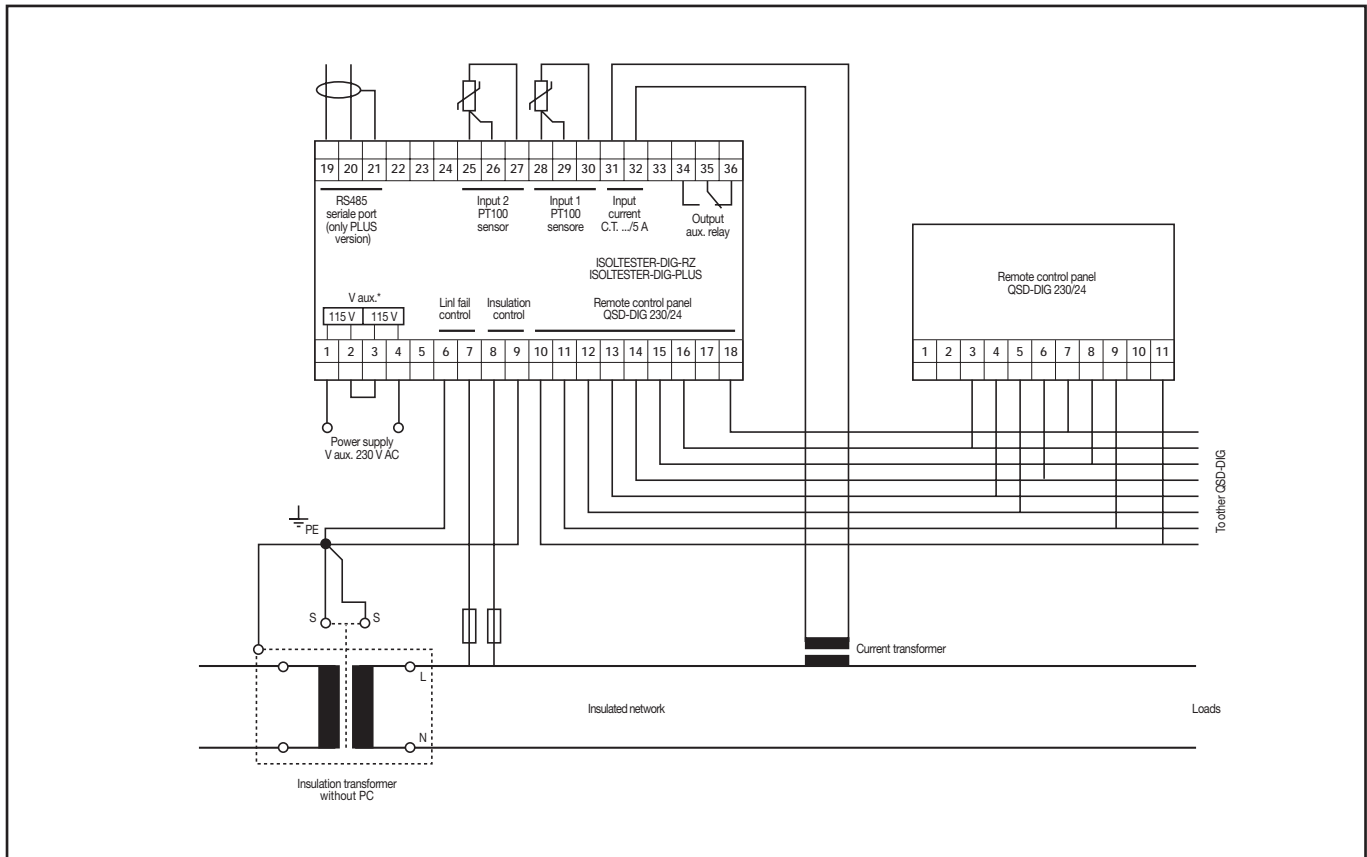

Wiring diagram with three-phase transformer

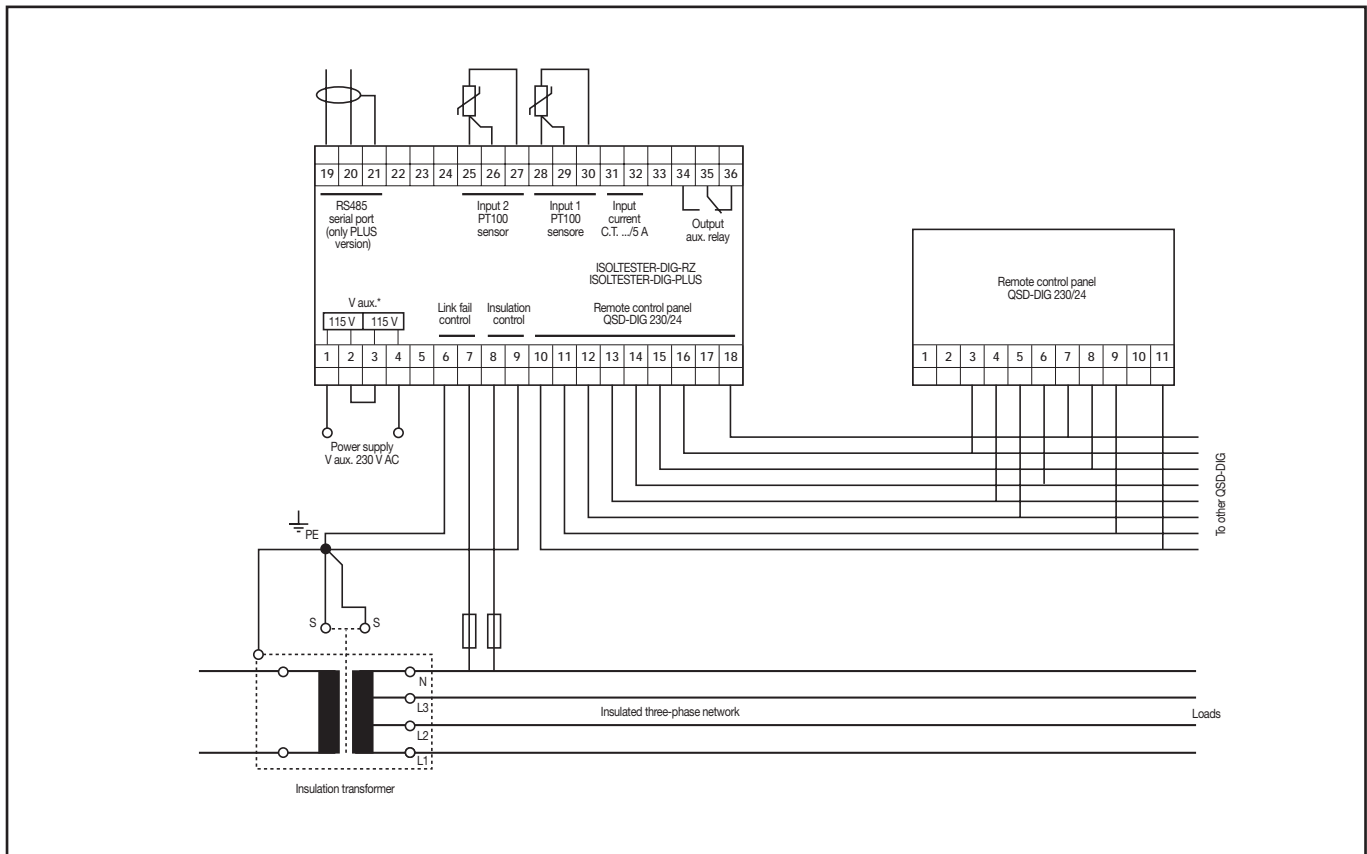

11

Selvtester

Wiring diagram with transformer 220/24

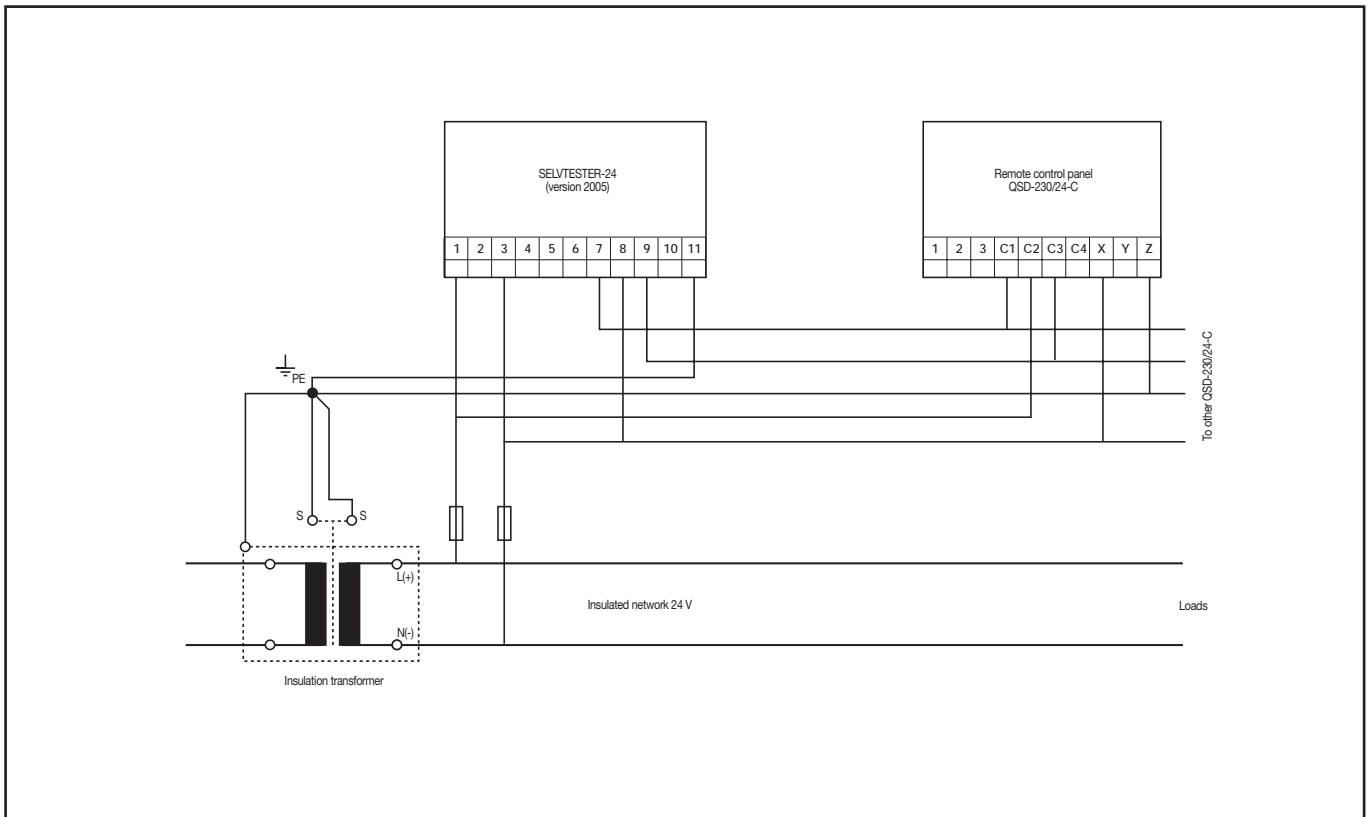

QSD-DIG

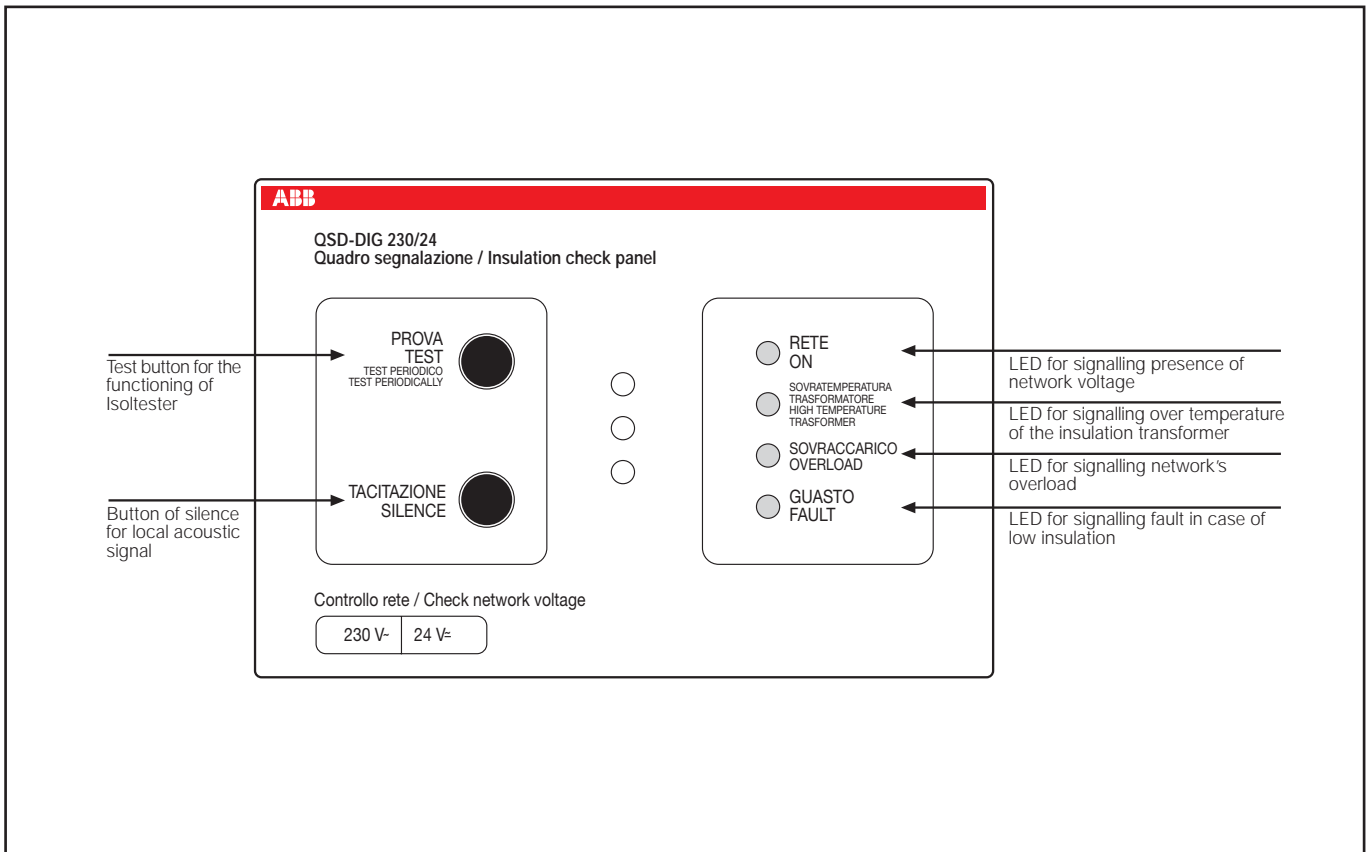

MODULAR TRANSFORMERS

The range of System pro *M* compact modular transformers consists of a series of safety transformers for general use, TS-C 25, 40 and 63 VA in accordance with the IEC-EN 61558-2-6 standard and another series of bell and chime TM transformers, with maximum secondary voltages of 12-24V and a maximum secondary power of 10-15-30-40VA, as well as TS, with maximum secondary voltages of 8-12-24V and a maximum secondary power of 8-16-24VA (some versions of the TS transformers are available with an integrated ON/OFF switch), according to reference standard IEC-EN 61558-2-8.

Modular safety transformers for general use, continuous functioning

The TS-C safety transformer is an insulation transformer for supplying SELV circuits (with extremely low safety voltage) or PELV circuits (with extremely low protection voltage). In contrast to the bell transformers, TS-C transformers can be used to continuously supply low voltage loads and they have a reduced voltage drop value. Even after a short-circuit they maintain their temperature below the specified limits. In addition they are equipped with a thermal sensitive restoring device which automatically restores power when the transformer is sufficiently cooled down or the load has been removed.

Bell transformers are available in 4 series:

Failure-proof for bells TM series

Following a possible anomalous use they will not continue to operate, but they are not dangerous to the user or to adjacent electric parts: the series includes 8 models with 10, 15, 30 and 40 VA power and 4, 8, 12 and 24 V output voltages.

Short-circuit proof not by construction for bells TS8 series

Even after a short-circuit they maintain their temperature below the specified limits. In addition they are equipped with a thermal sensitive restoring device which automatically restores power when the relevant part of the transformer is sufficiently cooled down or the load has been removed. The TS8 series includes 3 models with 8 VA power and output voltages of 4, 6, 8 and 12V.

Short-circuit proof not by construction for bells TS8/SW series

Unlike the previous versions this series is equipped with an ON-OFF pushbutton on the front side that allows the connection or disconnection of the transformer on the line. The TS8/SW series includes 5 models with 8 VA power and output voltages of 4, 6, 8 and 12 V.

Short-circuit proof not by construction for bells TS16/TS24 series

Even after a short-circuit they maintain their temperature below the specified limits. In addition they are equipped with a thermal sensitive restoring device which automatically restores power when the relevant part of the transformer is sufficiently cooled down or the load has been removed. The TS16/TS24 series includes 7 models with 16 and 24VA power and output voltages of 4,6,8,12 and 24V.

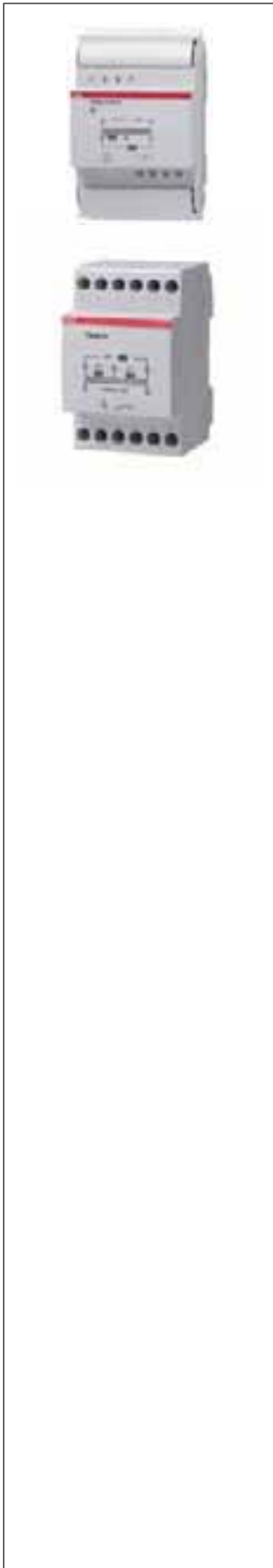

Index

MRDCs	
OVR Surge Protective Devices.....	12/4
E 259 installation relays.....	12/5
E 250 latching relays	12/6
AT electro-mechanical time switches.....	12/7
DT digital time switches	12/8
TW twilight switches	12/9
RAL overload alarms.....	12/11
LSS1/2 load shedding switches.....	12/12
SQZ3 phase and sequence relays	12/13

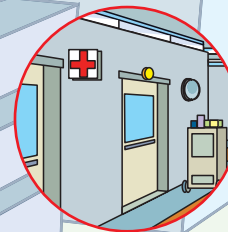
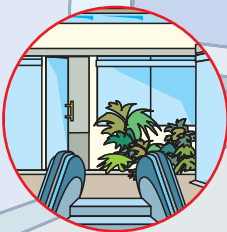
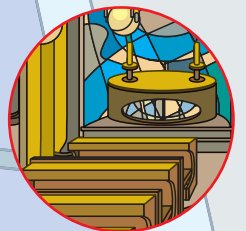
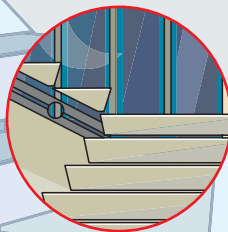
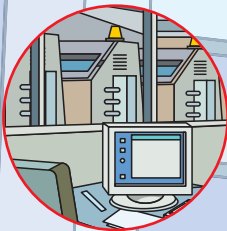
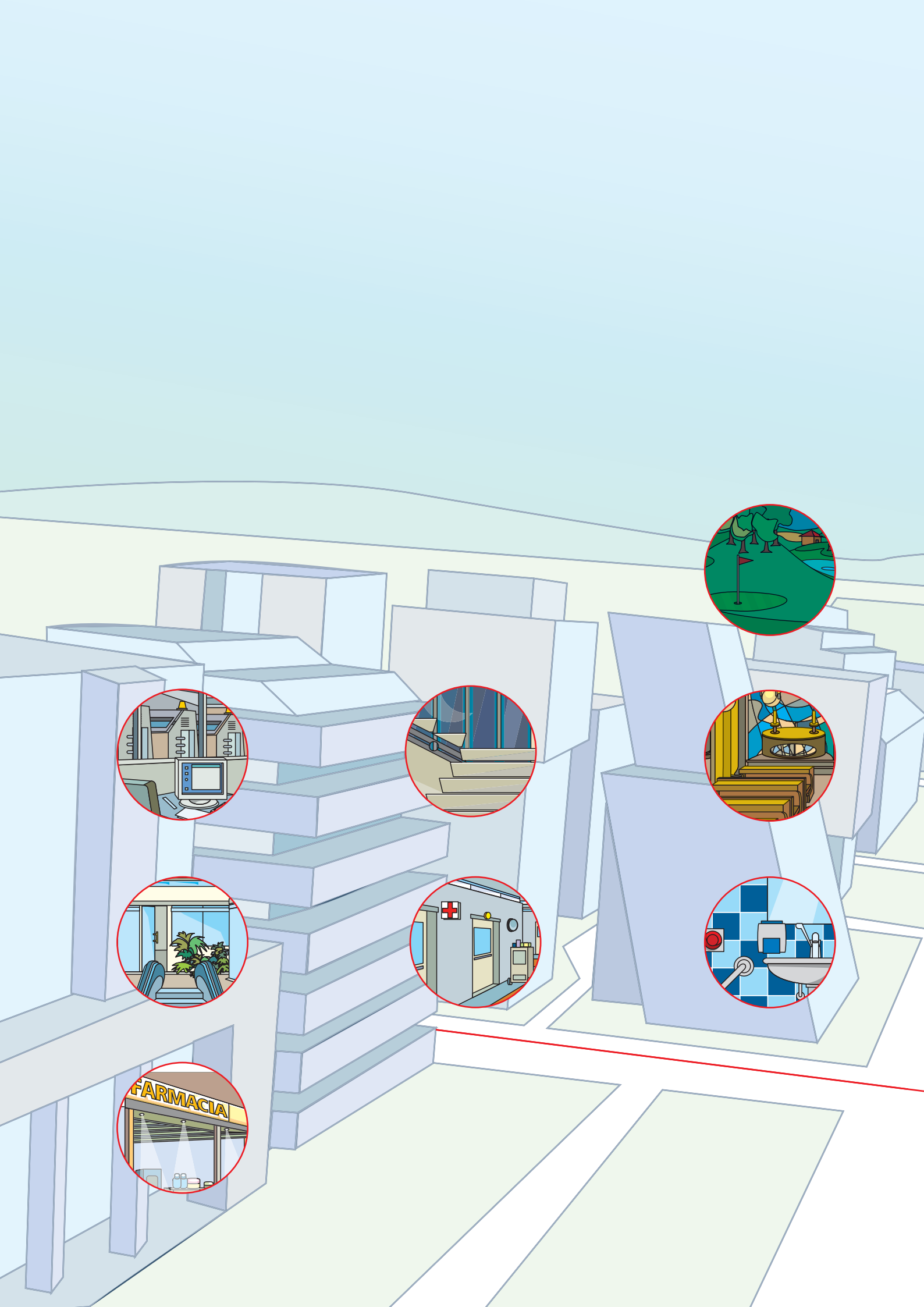

Examples of applications

Residential buildings

Public buildings

Commercial buildings

Industry

Handicraft

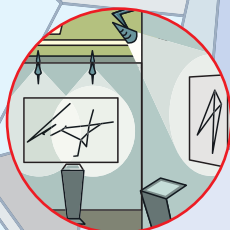
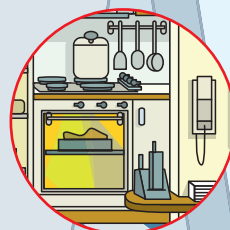
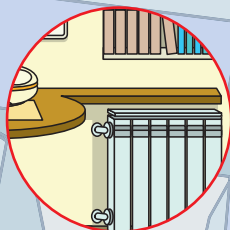

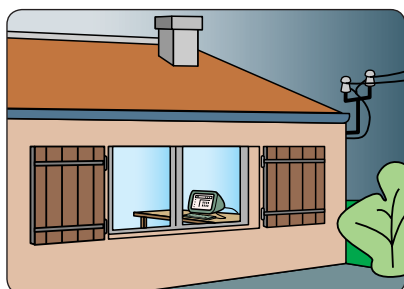
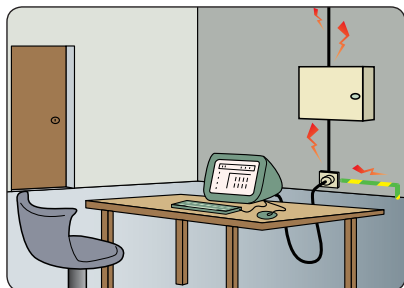
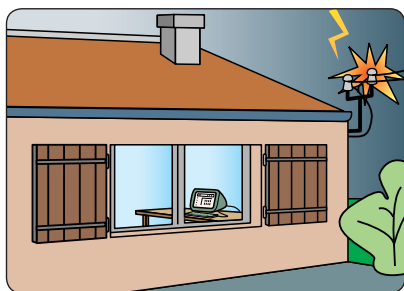

Operating principle

The Surge Protective Devices (SPDs), suitable for residential, commercial and industrial applications, are designed to limit transient overvoltage and run-off lightning currents.

Application environments

Application environments
The Surge Protective Devices (SPDs) are necessary in any environment where the lightning risk exists (direct lightning strike or overvoltages may occur).

Example of installation

As shown in the diagrams, one of the possible applications is to protect the equipment (TV, computer, ...) against overvoltage thanks to a Surge Protective Device (SPD) which ensures the protective in common mode (Ph-PE / N-PE) and differential mode (Ph-N).

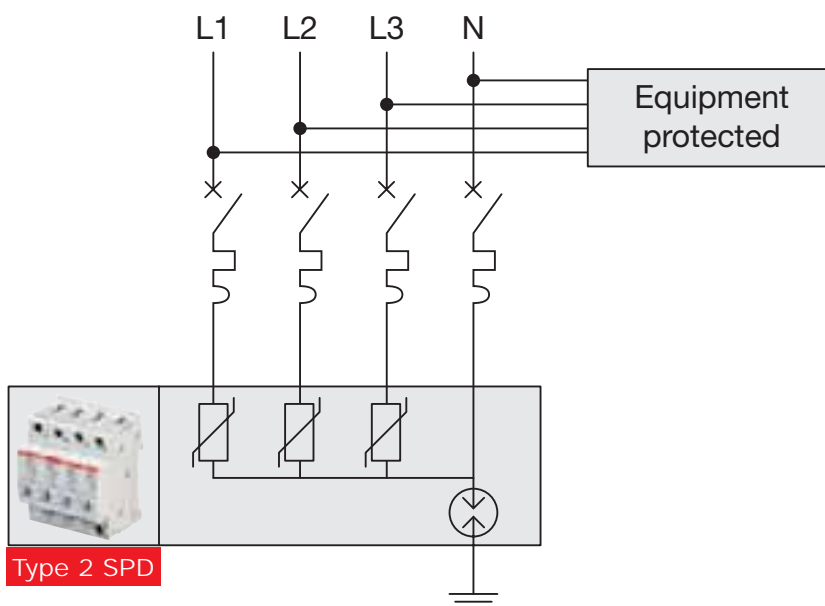

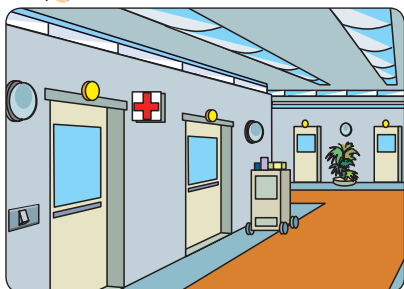
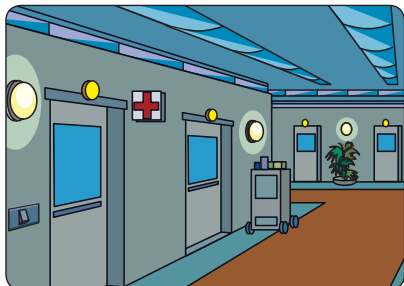
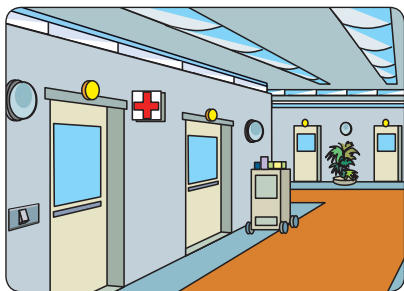

Operating principle

The E 259 installation relays, suitable for residential and commercial applications, are available in three versions: with NO contact, with NO and NC contacts, and with two NO contacts.

Application environments

The E 259 installation relays are particularly indicated in any environment and situation where it is necessary to control considerable power loads (i.e. lighting systems).

Example of installation

As shown in the diagrams, one of the possible applications is to mount the E 259 R11 installation relay with a NO and a NC contact inside the electric system of a hospital ward. The first control sent through pushbutton to the lighting circuit will switch off the ceiling lights and switch on the corridor lamps, while the second impulse returns to the previous state.

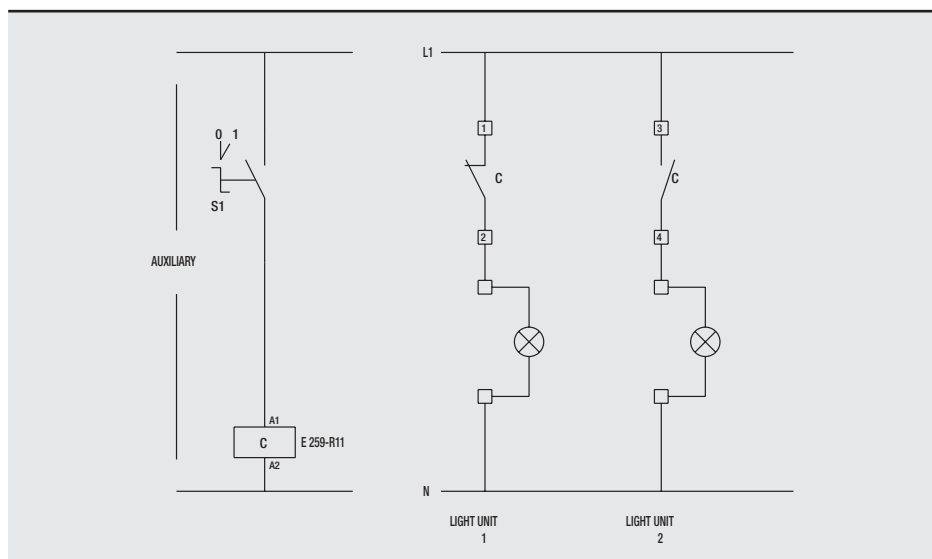
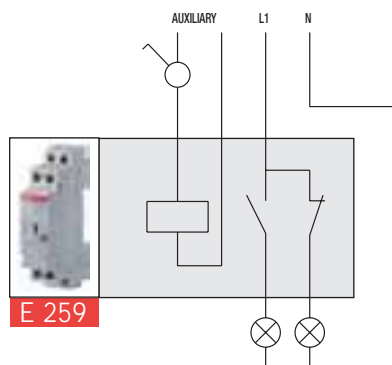

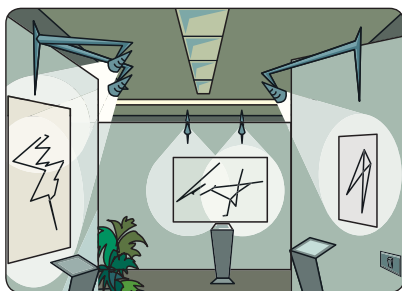
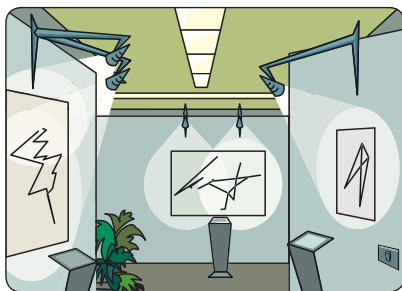
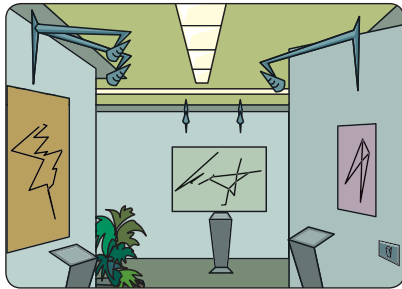

Operating principle

The two contacts of the E 255 latching relays switch the position (open/closed) at each impulse according to a sequence programmed by the control pushbutton circuit.

Application environments

The E 255 latching relays are particularly indicated in environments and situations requiring the load sequential control through a single pushbutton circuit (offices, restaurants, etc.).

Example of installation

As shown in the diagrams, one of the possible applications is to mount the E 255 latching relays inside the lighting system of an art gallery. The first pushbutton impulse will switch on the ceiling lights, the second triggers the wall lamps, the third switches off the ceiling lights and the fourth switches off the wall lamps.

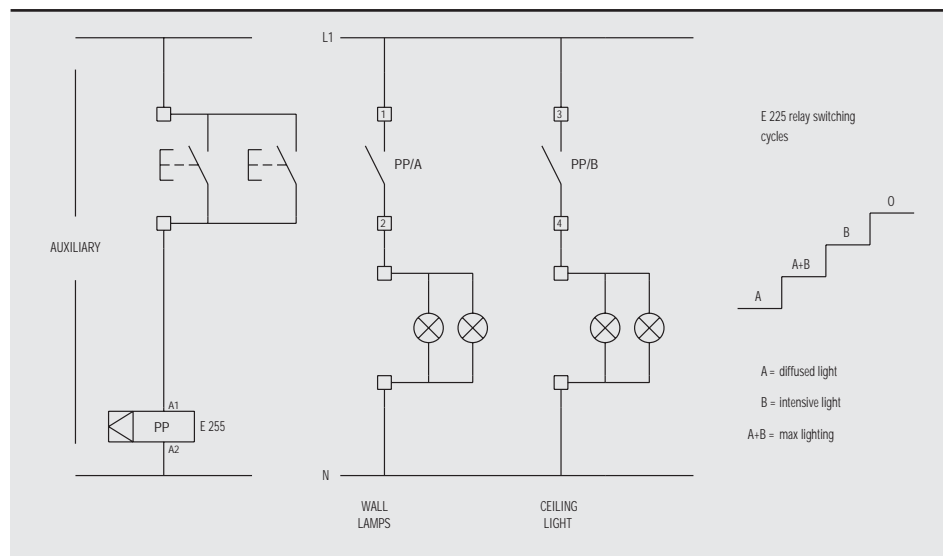
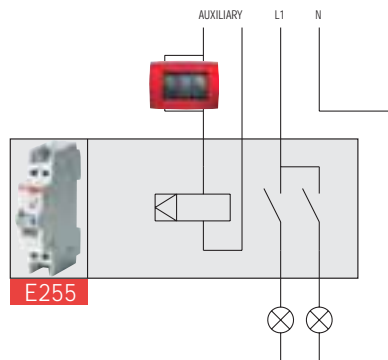

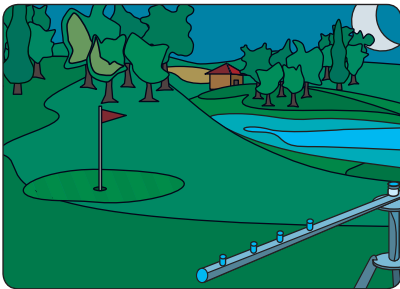

Operating principle

The AT electro-mechanical time switches enable to control the circuit opening/closing according to a daily or weekly program or to manually set permanent ON/OFF operation.

Application environments

The AT electro-mechanical time switches are particularly indicated in any environment and situation where it is necessary to program system load operation according to a daily or weekly frequency (shop lighting system, public buildings, heating systems, irrigation systems, etc.).

Example of installation

As shown in the diagrams, one of the possible applications is to mount the AT3-7R electro-mechanical time switch inside the power supply circuit of a golf field. In this case the device programming enables the daily activation of the irrigation system at a preset time

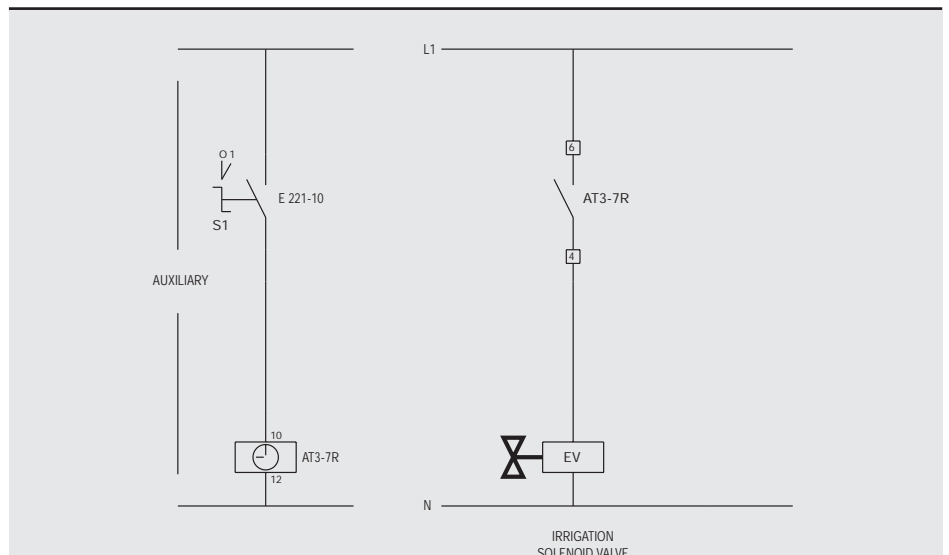
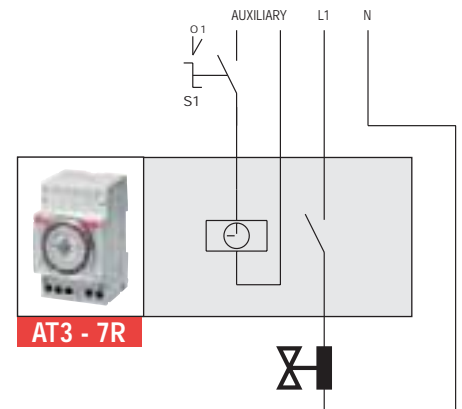

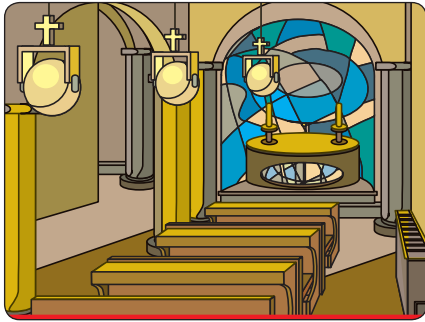

Operating principle

The DT two-channel digital time switches enable to open and close circuits according to a daily or weekly program, controlling single loads or group of loads even when they require different time controls with a common time reference.

In this example, the digital time switch DT2 allows the operation of heating as well as lighting systems of a church when services are performed; when no service is performed, the device only controls the heating system.

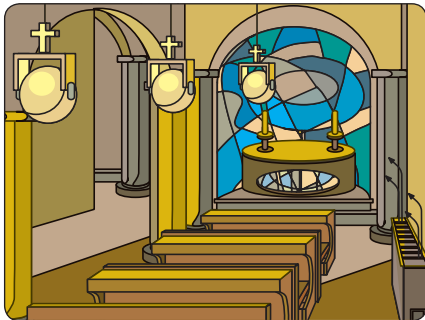

Application environments

The DT2 two-channel digital time switches are particularly indicated in environments and situations requiring the management of multiple loads according to a time program flexible enough to include or exclude their application based on the day of the week (offices, schools, public areas, etc.).

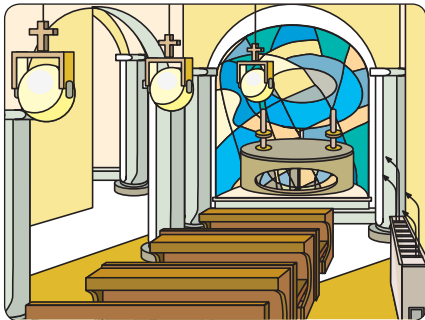

Example of installation

As shown in the diagrams, one of the possible applications is to mount the DT2 two-channel digital time switch inside the power supply circuit of a church, where in the days when no service is performed only the heating system is activated (programmed on one of the two channels) at a preset time, while on Sundays and when services are performed the lighting system is also switched on (through a program on the second channel). According to the controlled system power, the activation is performed by an ESB contactor.

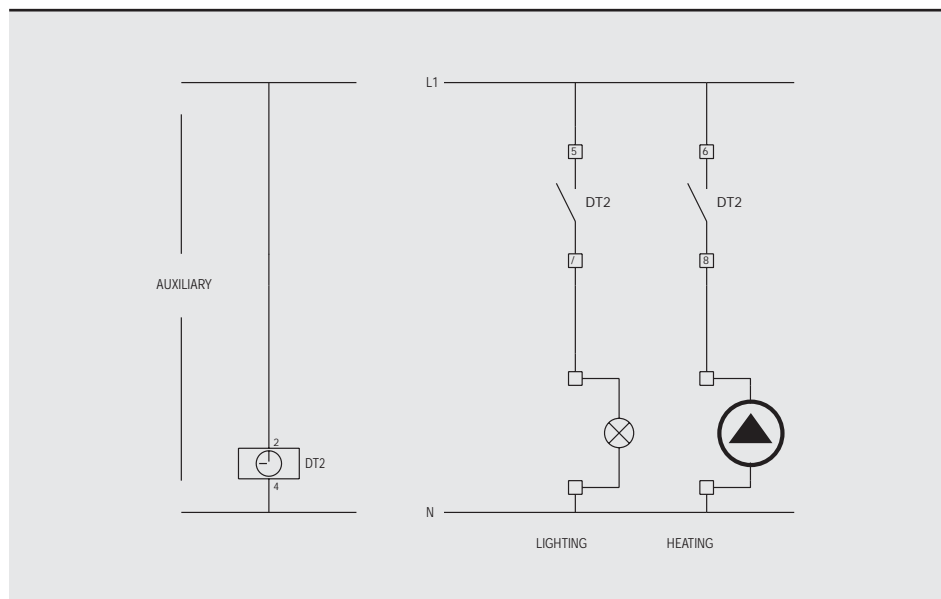
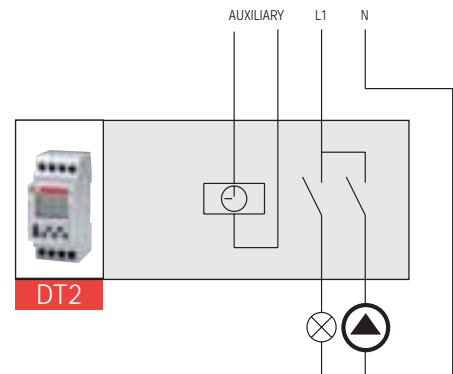

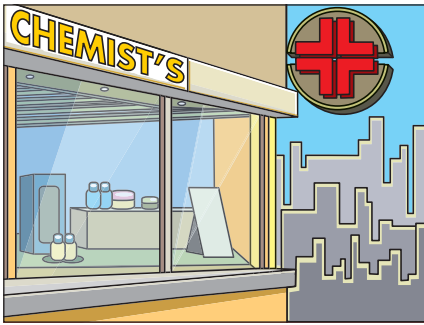

Operating principle

The diagram shows the installation of the TW1-D twilight switches in the lighting system of a chemist's. When the external light decreases below a certain level (i.e. shop opening during evening hours), the device controls the lighting of windows and sign. When the chemist's is opened during the night, the switch-on of all lights is set through time programming.

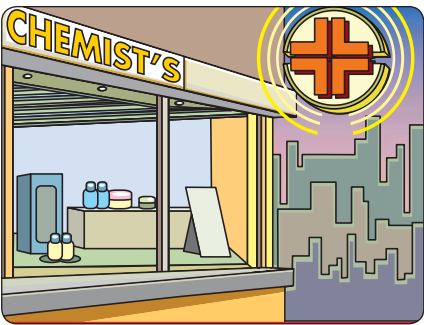

Application environments

The installation of TW1-D twilight switches is suitable for any environment and situation needing the rationalization of power consumption (shops, offices and public passage areas, parking, parks, etc.).

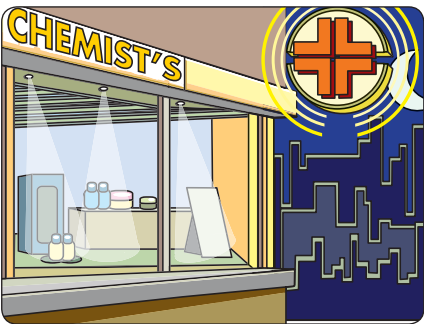

Example of installation

As shown in the diagrams, one of the possible applications is the installation of the TW1-D twilight switches in the lighting system of a chemist's. When the external light decreases below a certain level (i.e. shop opening during evening hours), the twilight switch controls the lighting of windows, sign and cross sign. The last one can have an intermittent switch-on/off because of E 234 TI time delay relay installation. When the chemist's is opened during the night, the switch-on of all lights (using the twilight switch) is set through date and time programming using time switch. When the chemist's is closed, the time switch programming switches off the windows and cross sign lights independently from twilight switch (sign ON).

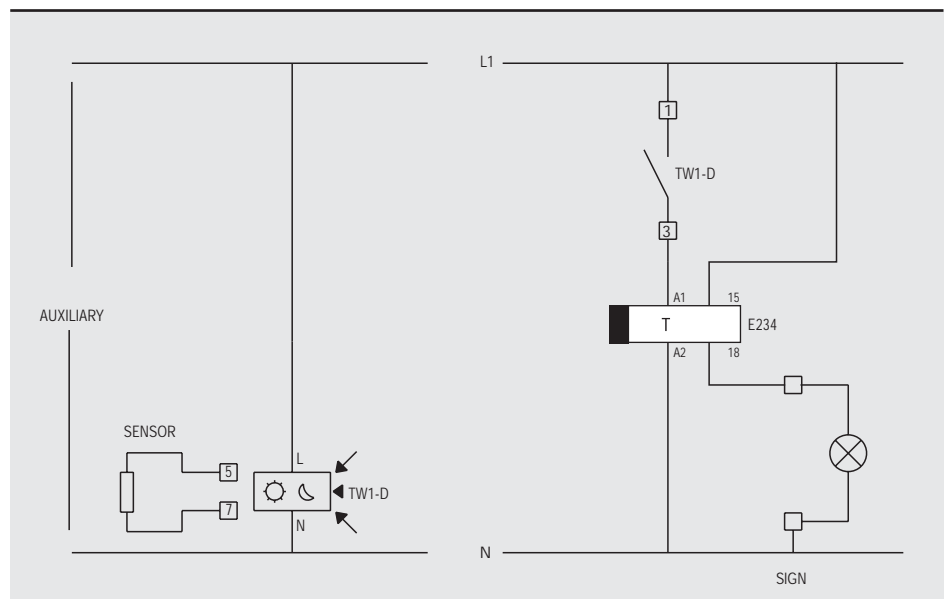
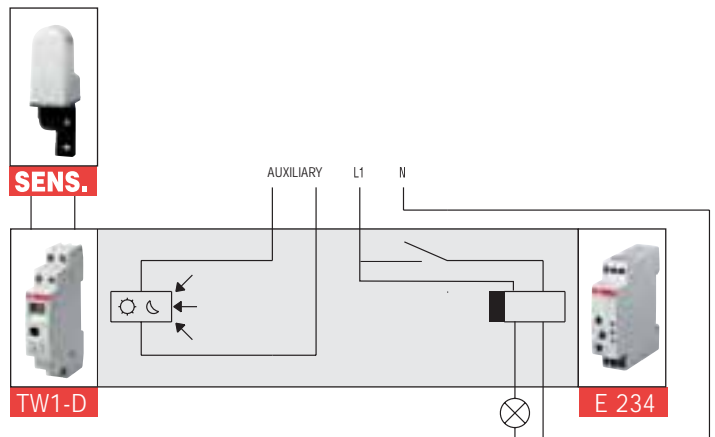



Operating principle

Installation of a twilight astronomical switch in a system is particularly useful in places and situations where light sources or other environmental conditions may cause changes in the Lux level.

In these cases, TWA-1 and TWA-2 enable control of the lighting system depending on the time when the sun rises and sets, based on the geographic location where they are installed.

Application environments

The TWA-1 and TWA-2 twilight astronomical switches are particularly suitable for use in applications where the operation of a twilight switch with external sensor is potentially subject to alteration or damage from external agents (e.g. smog, overexposure to light, vandalism etc.).

Example of installation

One cause of reductions in the level of ambient light is atmospheric smog. Particle deposits on the external sensor of a traditional twilight switch can over time compromise its operation, preventing the activation of the lighting systems controlled. As illustrated in the diagrams, it is possible to counter this type of problem by installing a TWA twilight astronomical switch, which controls the lighting based on the ambient light level calculated from the preset longitude and latitude parameters.

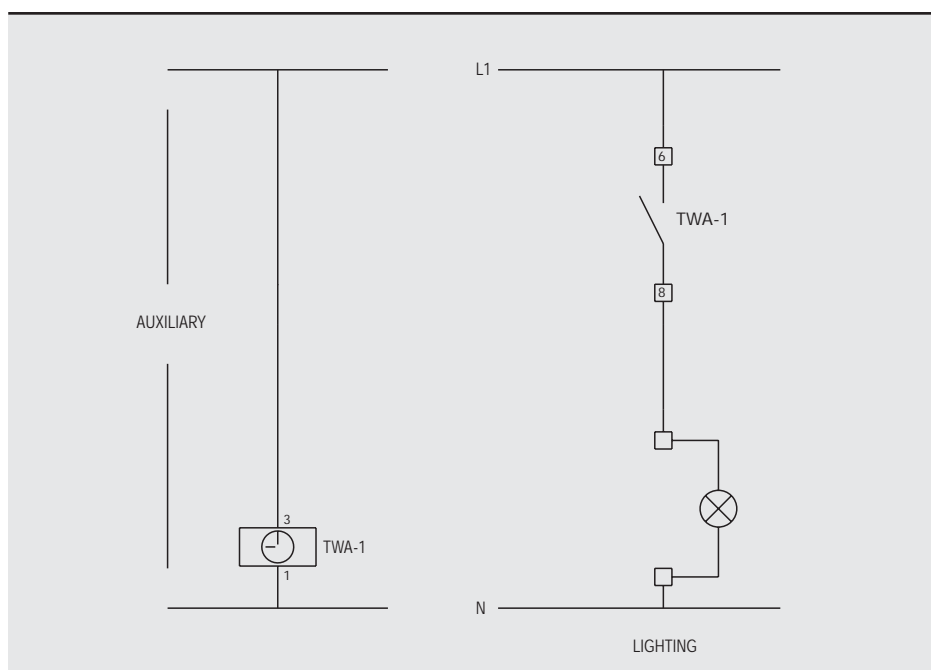
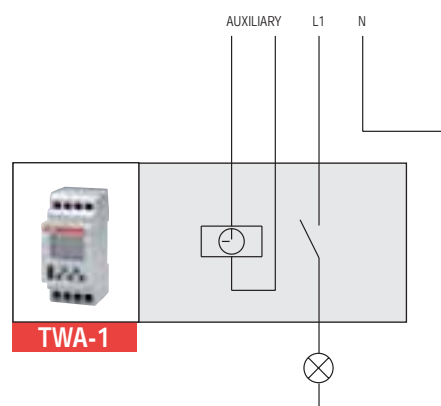

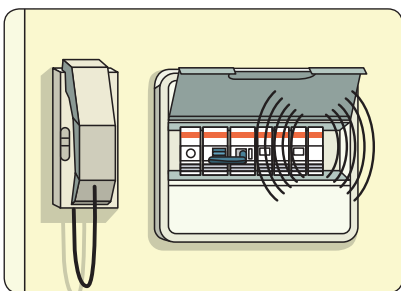
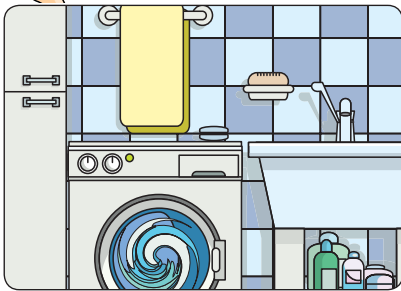
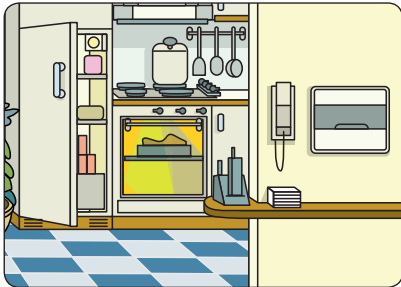
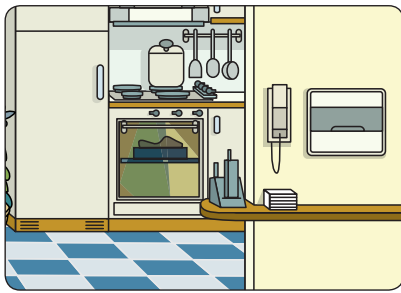

Operating principle

The RAL overload alarms constantly compare the maximum preset power consumption value to effective system power consumption. Approaching allowed threshold, they signal to disconnect one of the loads through acoustic alarm avoiding the main circuit breaker tripping. Connecting the S 9-T415 undervoltage release to the appropriate contact, the RAL overload alarms provide an acoustic alarm and simultaneously opens the circuit-breaker protecting one or more not primary loads.

Application environments

The installation of the RAL overload alarms is suitable for any environment and situation in order to avoid power consumption which could trip the limiting circuit breaker of the system.

Example of installation

As shown in the diagrams, one of the possible applications is the installation of the RAL overload alarms in the domestic system where the electric oven and washing machine are simultaneously switched on increasing the power consumption. When the power consumption approaches the preset threshold values, an acoustic alarm is activated and the washing machine switches off automatically through an undervoltage release.

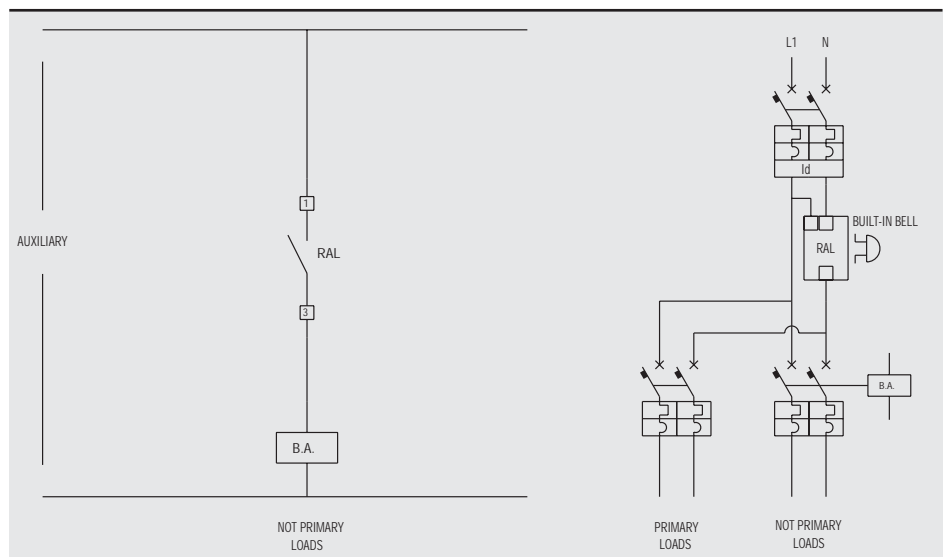
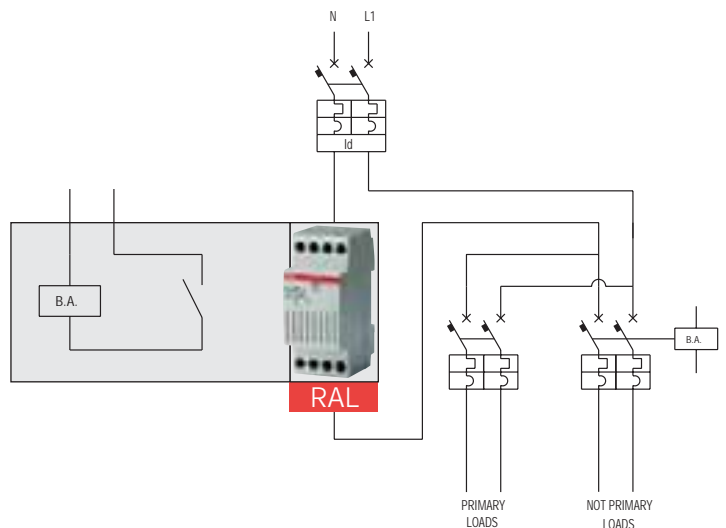

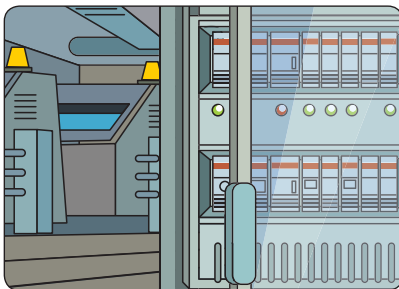
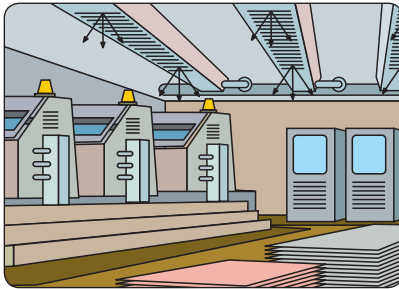

Operating principle

LSS1/2 load shedding switches are used in case of exceeding of consumption threshold allowed in the system by switching off in sequence one or two loads, if necessary. At preset intervals and until current consumption is not below the reference level, the switch tries to reset the disconnected loads.

Application environments

The installation of the LSS1/2 load shedding switches is suitable for any environment and situation where it is necessary to control electric energy consumption within consumption limits allowed in the system.

Example of installation

As shown in the diagrams, one of the possible applications is the installation of the LSS1/2 load shedding switches in a printing office system, where the conditioning switch-on causes the exceeding of the energy consumption threshold defined with the supplying company by contract. The LSS1/2 load shedding switch preserves printing machines operation by switching off one or two primary loads automatically (i.e. night conditioning and lighting), where ON red leds indicate temporary OFF. After a preset interval, the switch checks that current consumption values fall within the limits again trying to reset the previously disconnected loads.

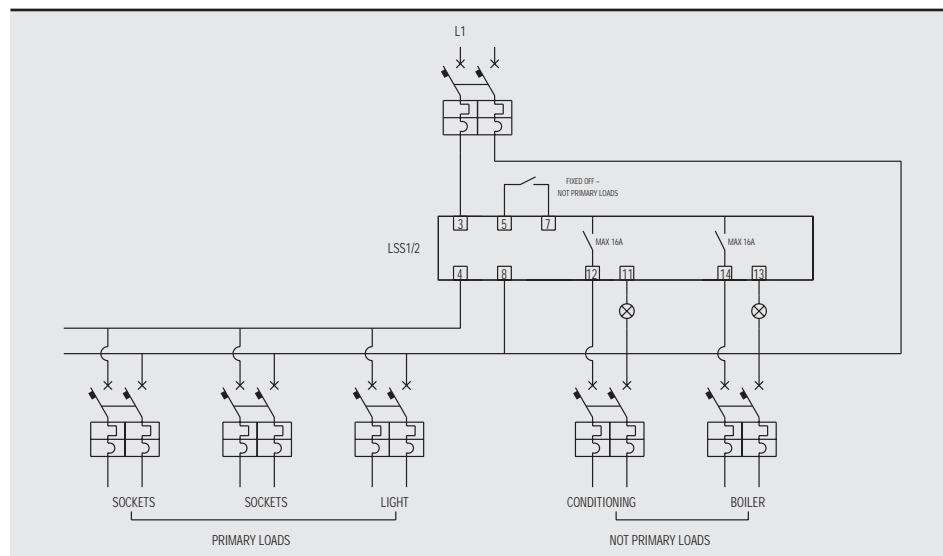
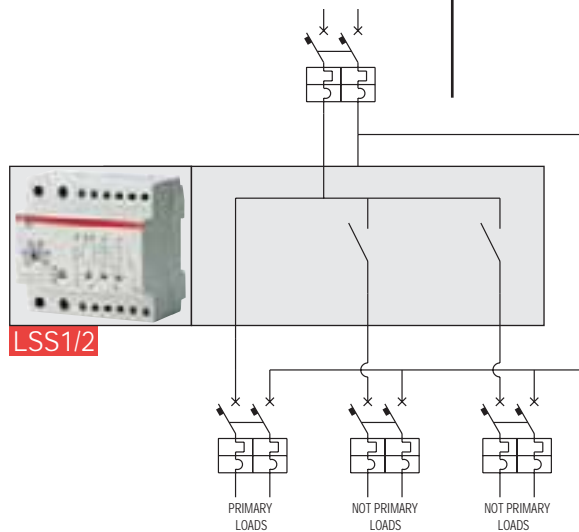

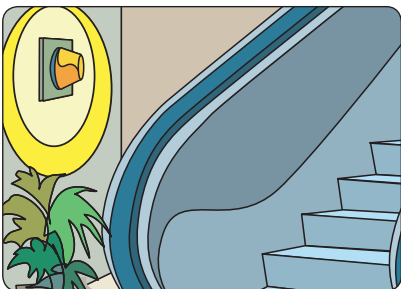
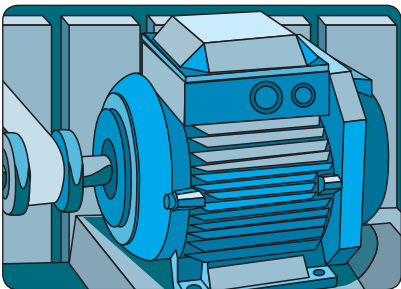
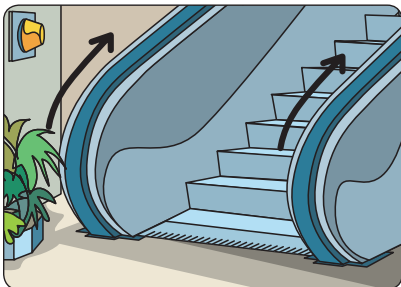

Operating principle

Through an output relay with contact in safety switching, the SQZ3 phase and sequence presence devices for 400 V a.c. three-phase networks enable the phase and sequence presence management monitoring also the minimum voltage (adjustable up to 70% of V_n). In case of any defect, the device operates within a range from 2 to 20 seconds, with the opportunity to control the appropriate acoustic signals, motor controlling contactors or circuit breakers.

Application environments

The installation of the SQZ3 phase and sequence presence relays are particularly suitable for any environment and situation where it is necessary to control the three-phase network operation promptly signalling any defect.

Example of installation

As shown in the diagrams, one of the possible applications is the installation of the SQZ3 phase and sequence presence relays in a department store, where the escalator supply circuit has a phase variation determining the SQZ3 relay intervention on the ESB contactor and causing the motor block and the alarm lighting indication.

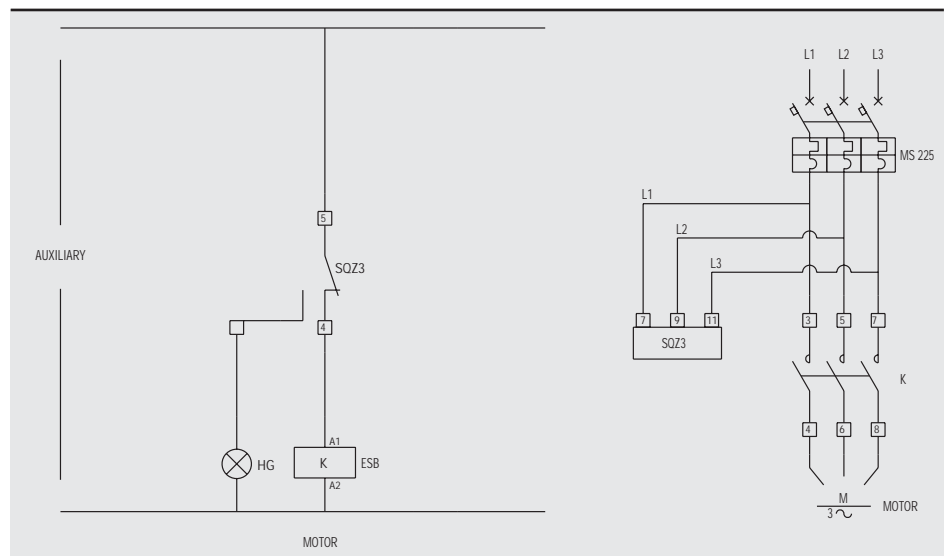
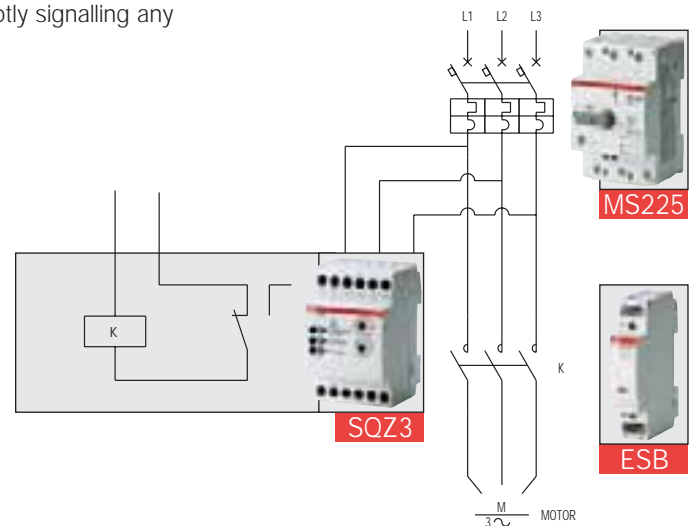

Index

MCBs	
S 200	13/2
S 200 U-UP	13/3
S 9..	13/3
S 280	13/4
S 290	13/4
S800	13/4
RCDs	
F 200	13/5
DDA 200	13/6
FS 201	13/7
DS 200	13/7
DS 9..	13/8
DS 271	13/8
DDA for S 290, S800 and DS800 series.....	13/9
Auxiliary elements and accessories for MCBs and RCDs	
Auxiliary elements and accessories for S 200, F 200 and DS 200 series	13/10
Auxiliary elements and accessories for S 9.. and DS 9.. series.....	13/12
Auxiliary elements and accessories for S 280, S 290 and S800 series	13/12
Other accessories.....	13/13
MDRCs	
Surge Protective Devices	
OVR range.....	13/21
Protection devices	
RD2 residual current monitors and toroidal transformers.....	13/23
E 930 fuse holders.....	13/24
M2160-M2060 fuse switches	13/24
Command devices	
E 259 installation relays.....	13/25
E 200 switches	13/25
E463/3, E480/3 switches	13/25
E 250 latching relays	13/26
E 260 latching relays	13/26
E 220 switches	13/26
E 220 pushbuttons and indicator lamps	13/27
ESB/EN series contactors	13/27
E 234 CT-D electronic timers.....	13/28
E 232 staircase lighting time delay relays.....	13/28
STD dimmers.....	13/28
AT electro-mechanical time switches.....	13/29
DT digital time switches.....	13/29
CL logic relays	13/30
Load management devices	
E 450 priority switches.....	13/31
TW twilight switches	13/31
RAL overload alarms	13/32
LSS1/2 load shedding switch	13/32
SQZ3 phase and sequence relay	13/33
LEE 230 power failure signalling lamp.....	13/33
Max./min. current/voltage ammetric and voltmetric relays.....	13/33
E 235 mains disconnection relays.....	13/34
E 236 undervoltage monitoring relays.....	13/34
Measurement devices	
Analogue measurement instruments.....	13/35
Digital measurement instruments	13/35
DMTME multimeters.....	13/36
MCV-MCA voltmetric and ammetric switches.....	13/36
CT current transformers	13/37
CTSM summing current transformers	13/47
TV voltage transformers	13/47
Shunts	13/49
CONV current and voltage converters.....	13/50
CNV transducers for power factor meters.....	13/50
E 233 hour counters	13/50
HMT hour counters	13/50
Insulation monitors	13/51
EMT electronic energy meter	13/52
ODINsingle electronic single phase energy meters.....	13/52
ODIN Meter electronic three-phase energy meters.....	13/52
DELTAsingle electronic single phase energy meters.....	13/53
DELTAplus electronic three-phase energy meters.....	13/53
Other modular devices	
TS-C safety isolating transformers for general use	13/54
TM/TS bell transformers	13/54
CP-D primary switch mode power supplies	13/55
Bells and buzzers	13/56
Modular sockets.....	13/56
MA1-8001 DIN rail adapter.....	13/56



S 200

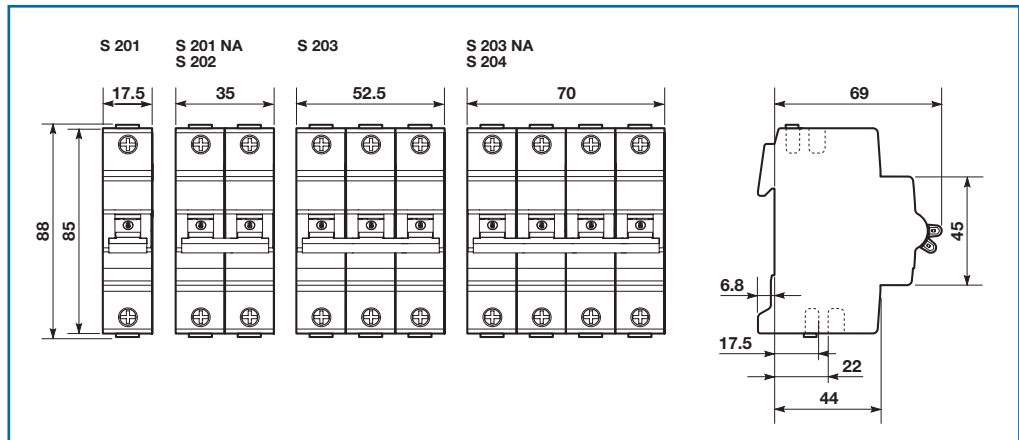

S 200 with bottom-fitting auxiliary contact

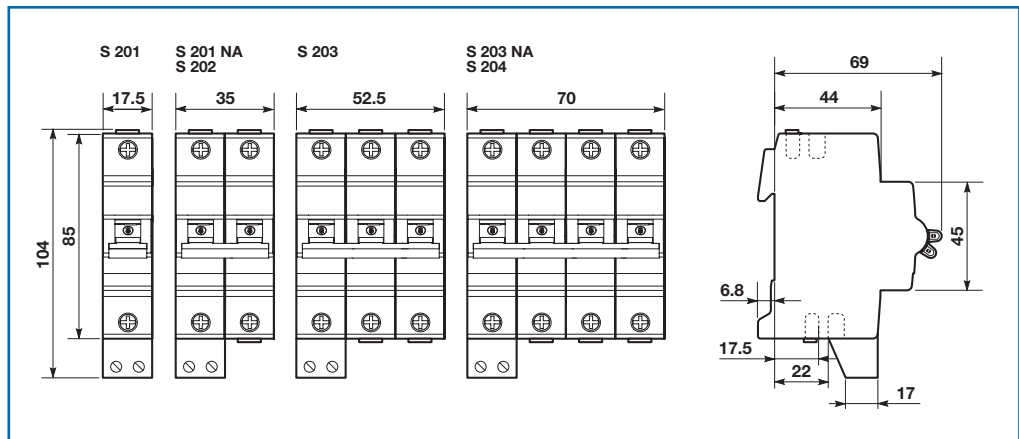



S 200 U-UP

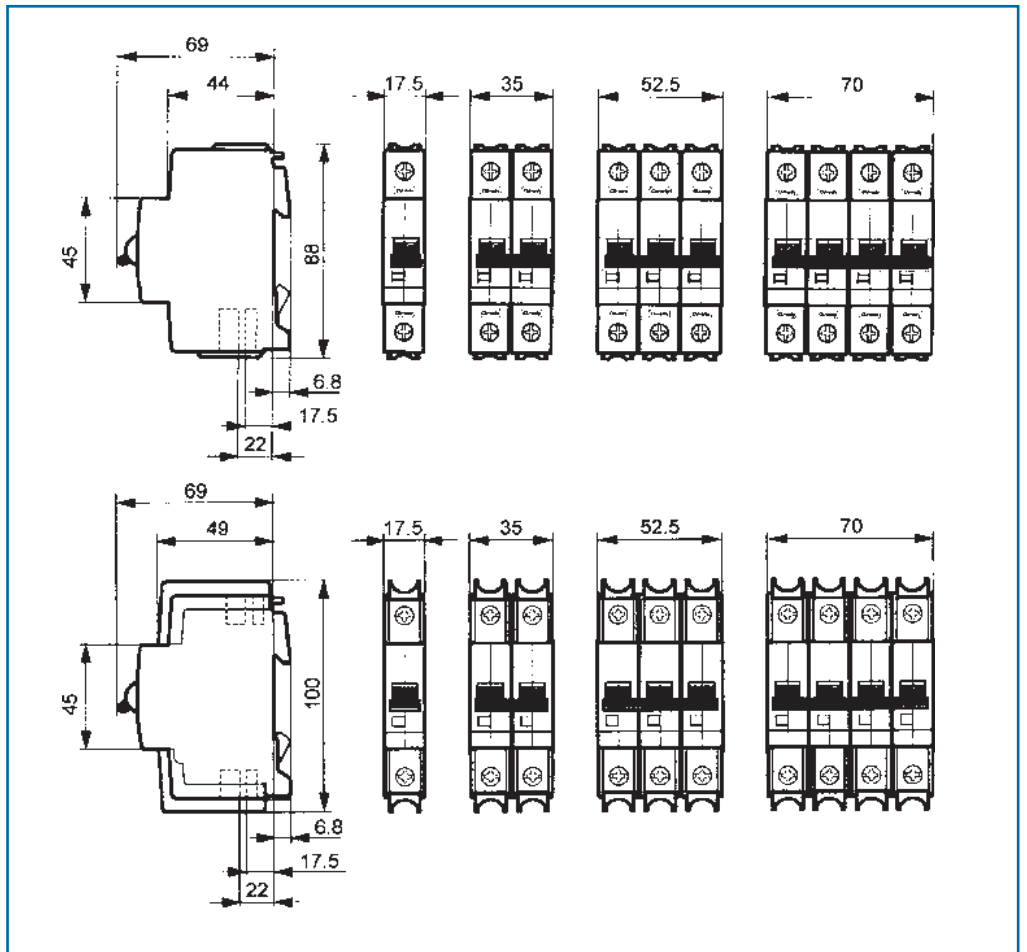

S 9..

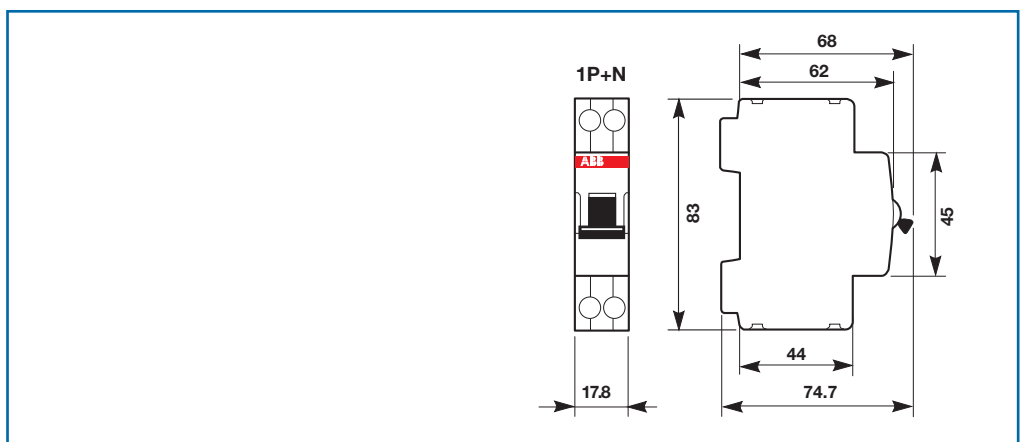



S 280

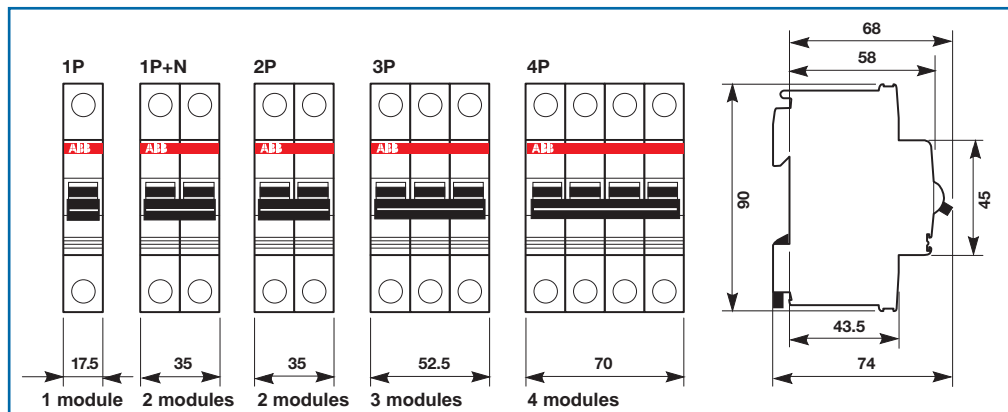

S 290

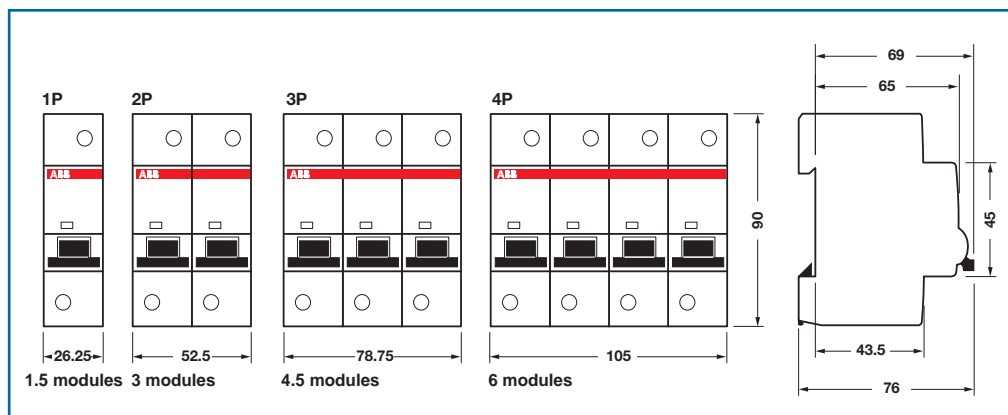

S800 S - S800 N - S800 S-R

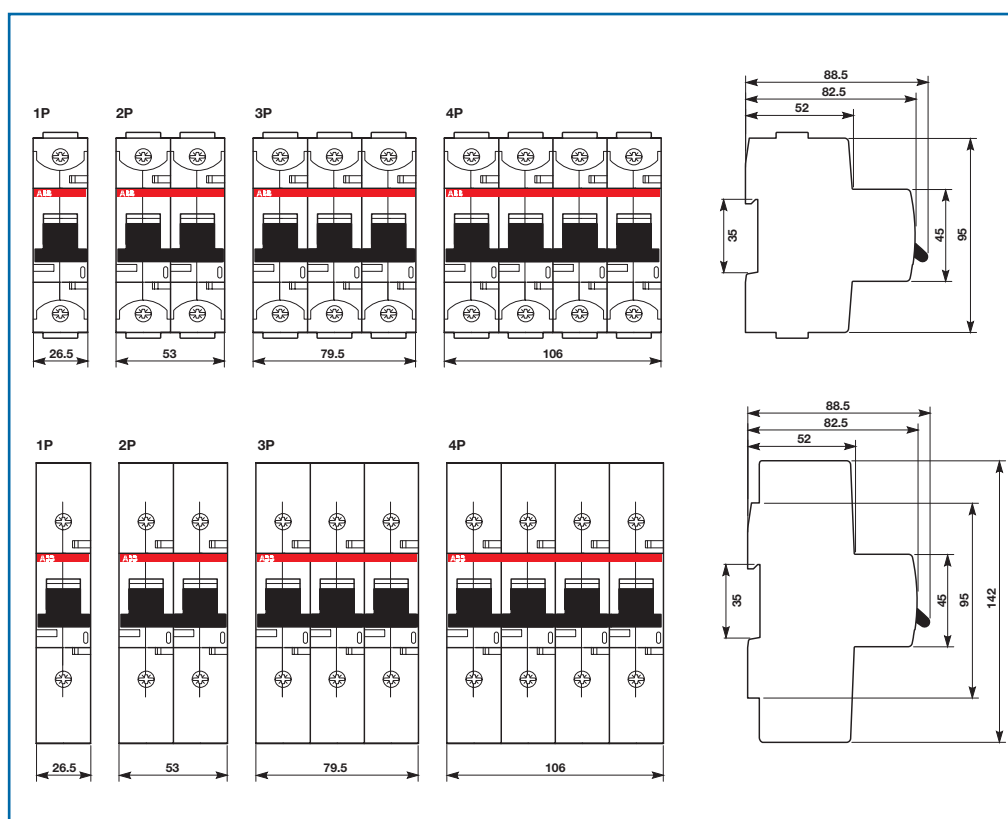

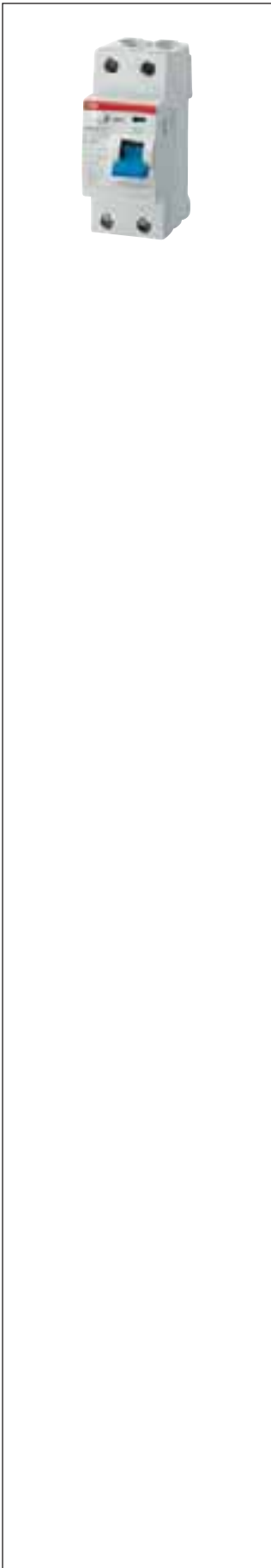

F 200

F 200

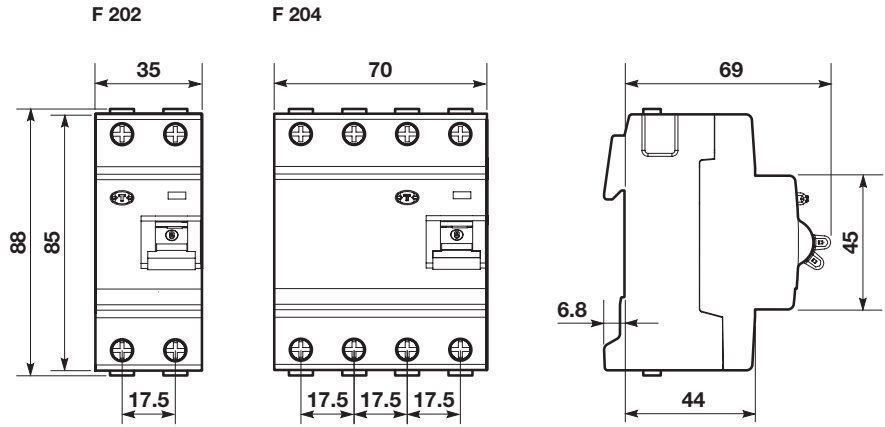

F 204 B, F 204 125 A

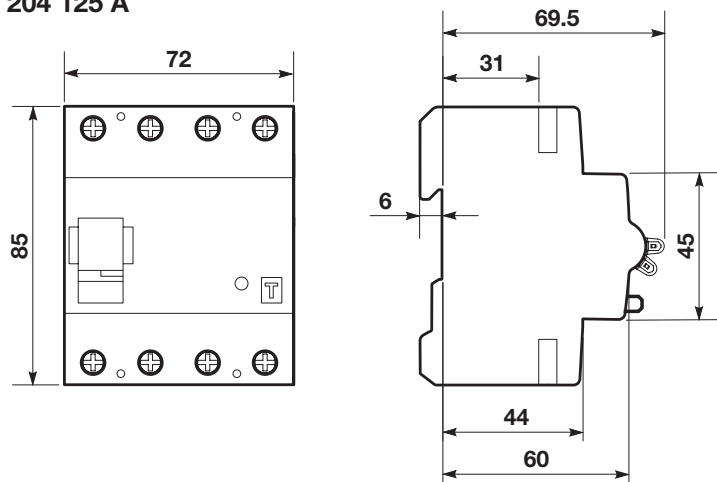



DDA 200

In=25-40 A

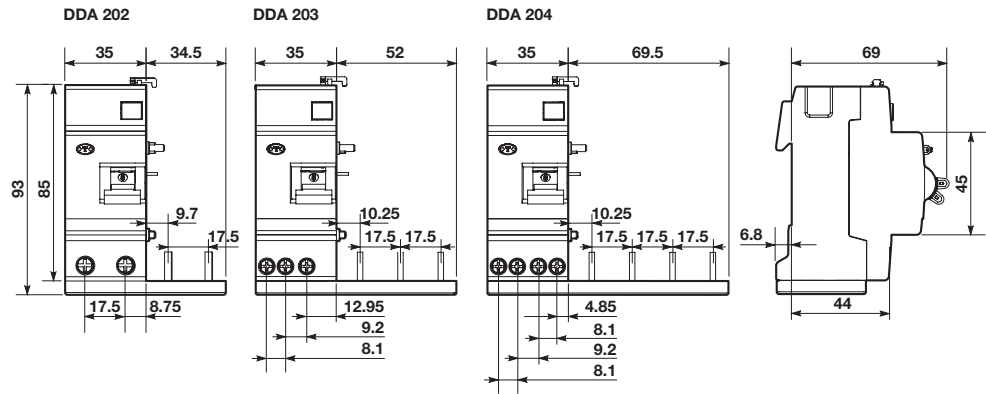

In=63 A

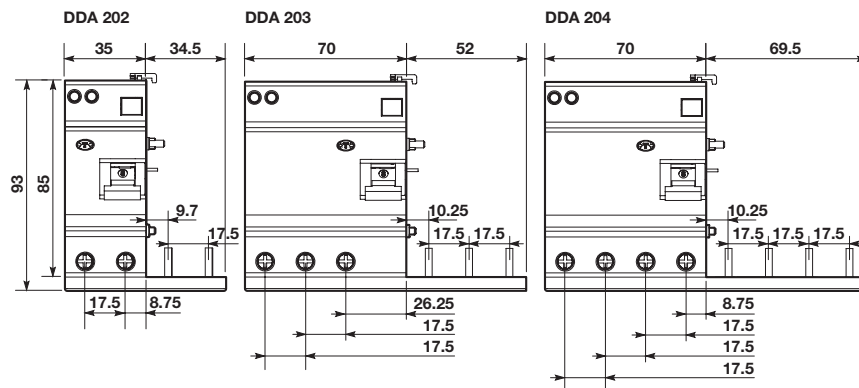



FS 201

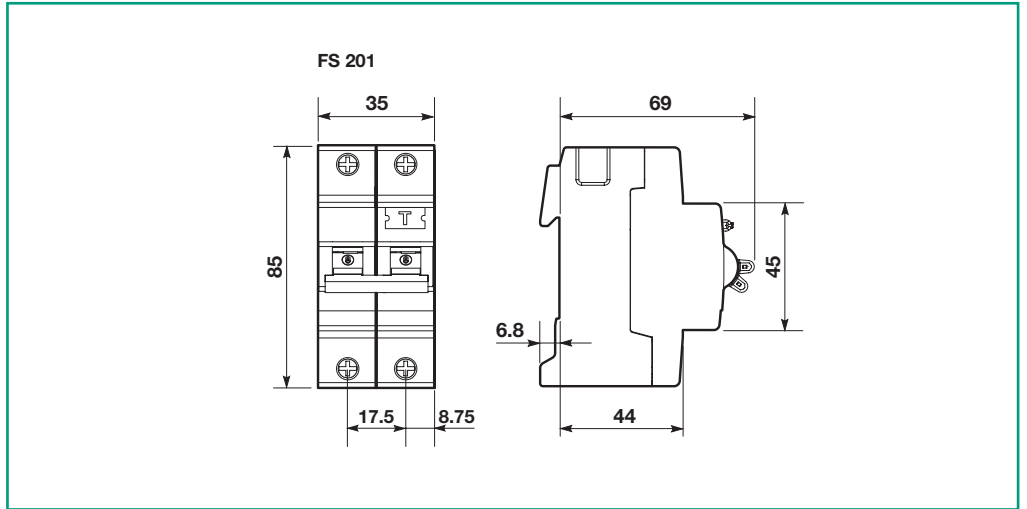

DS 200

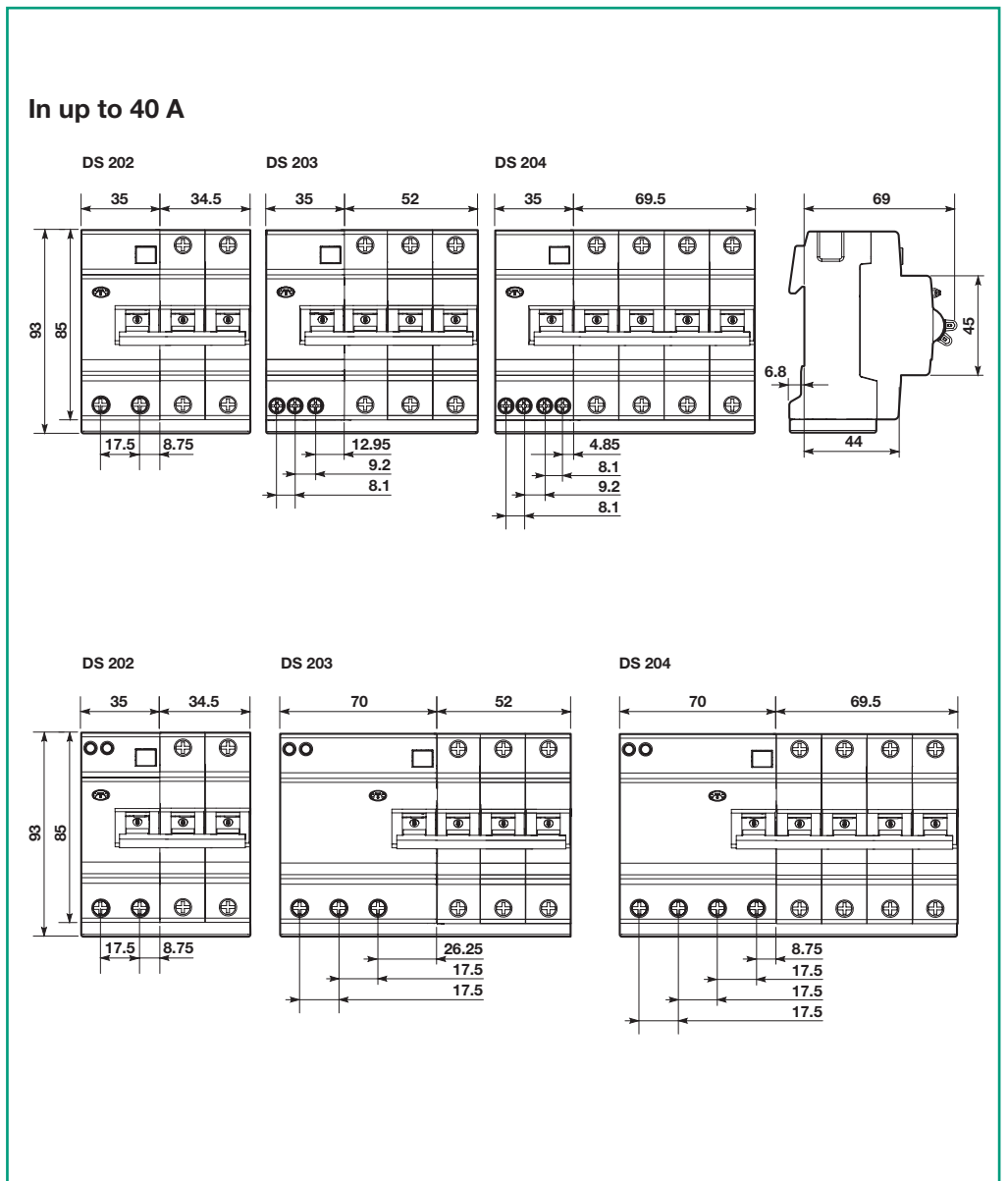



DS 9..

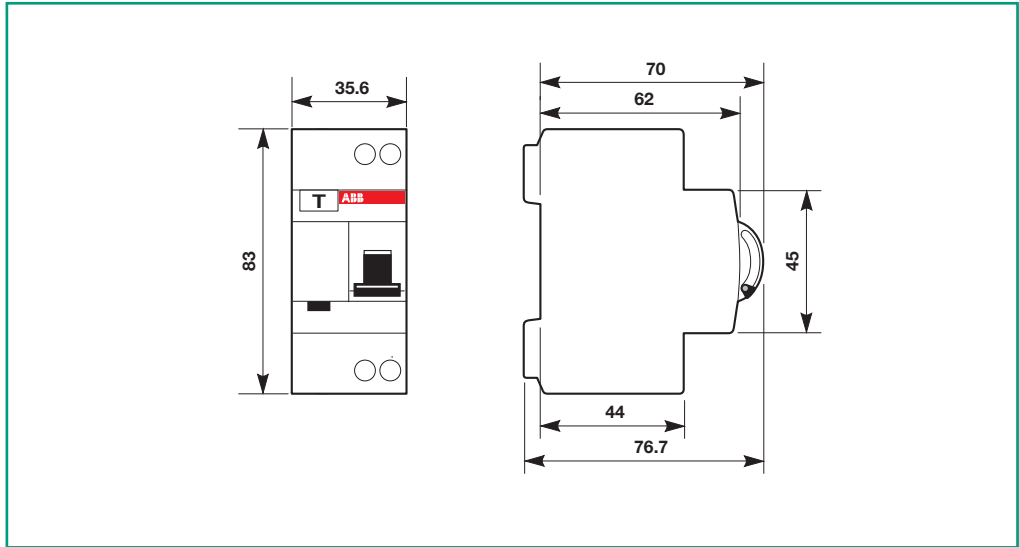

DS 271

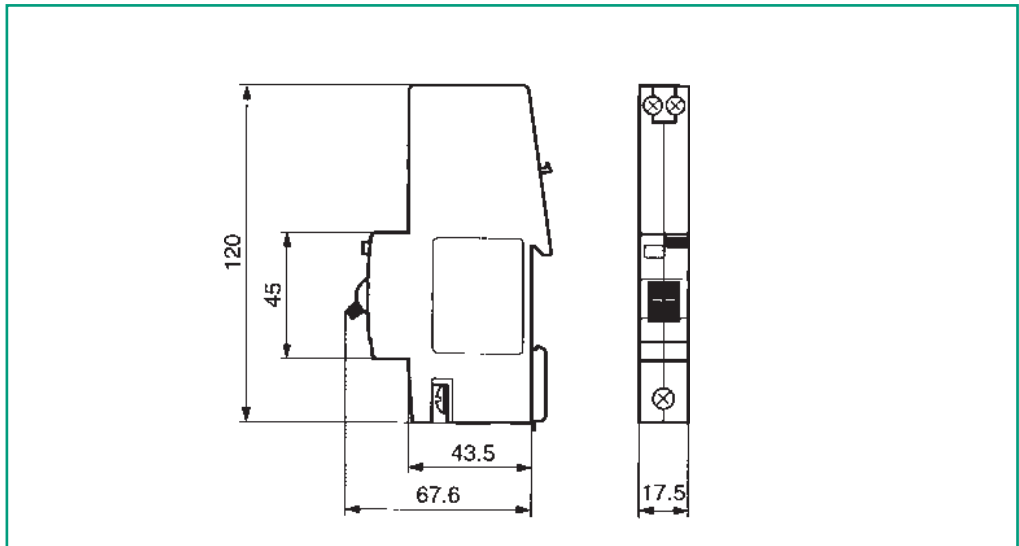



DDA for S 290 series

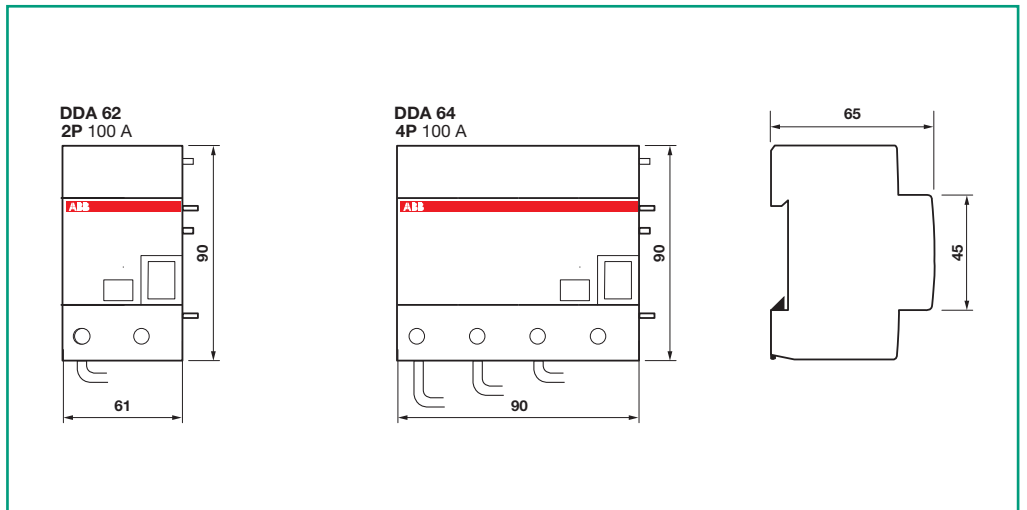

DDA 800 for S800 and DS800 series

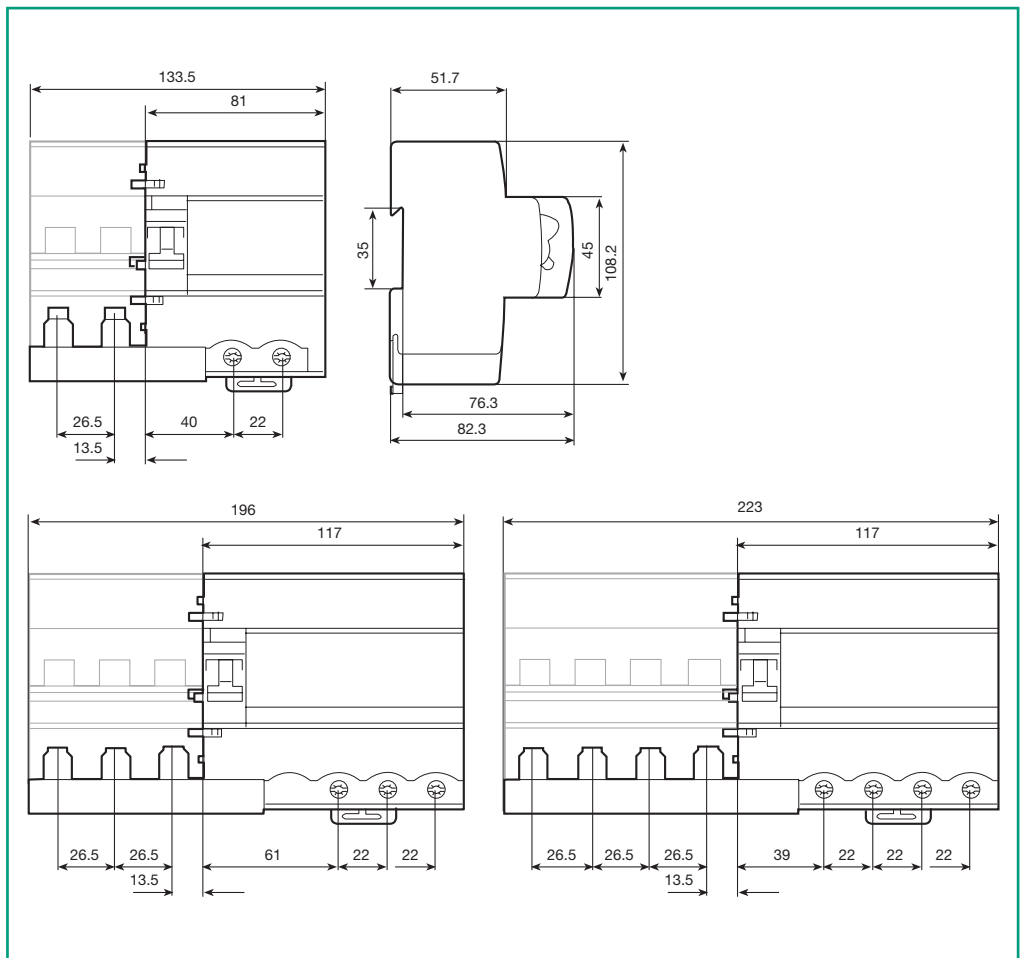

Auxiliary elements for S 200 series

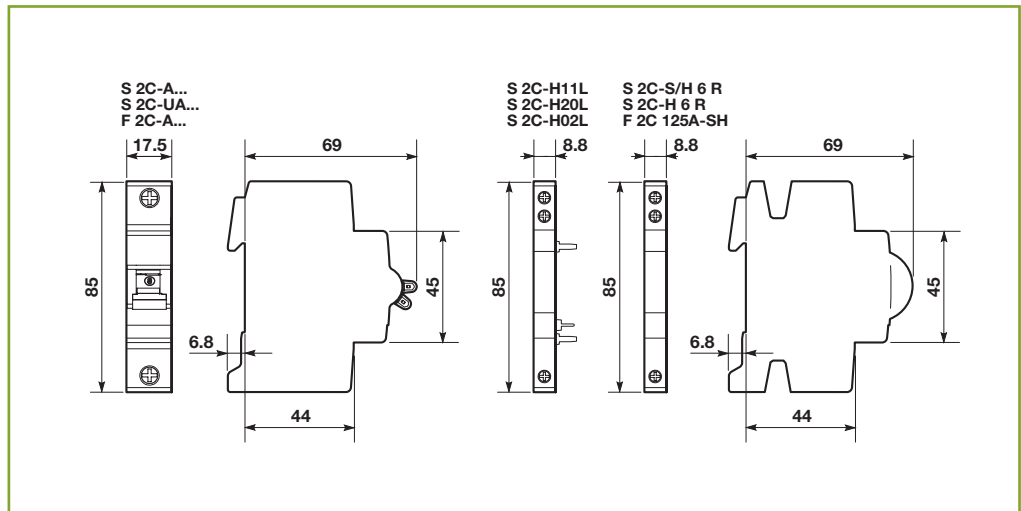

Bottom-fitting auxiliary contact (with S 200 MCB)

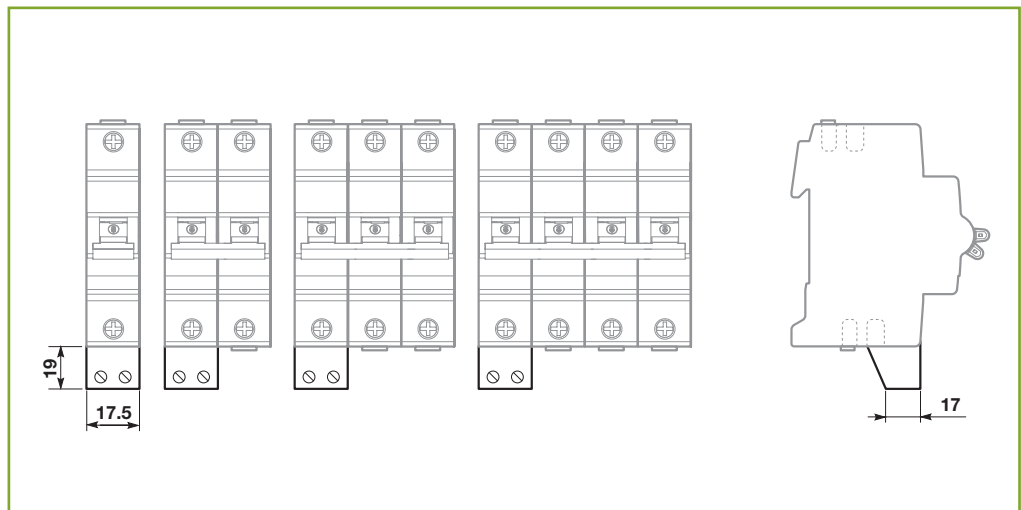

S 2C-EST

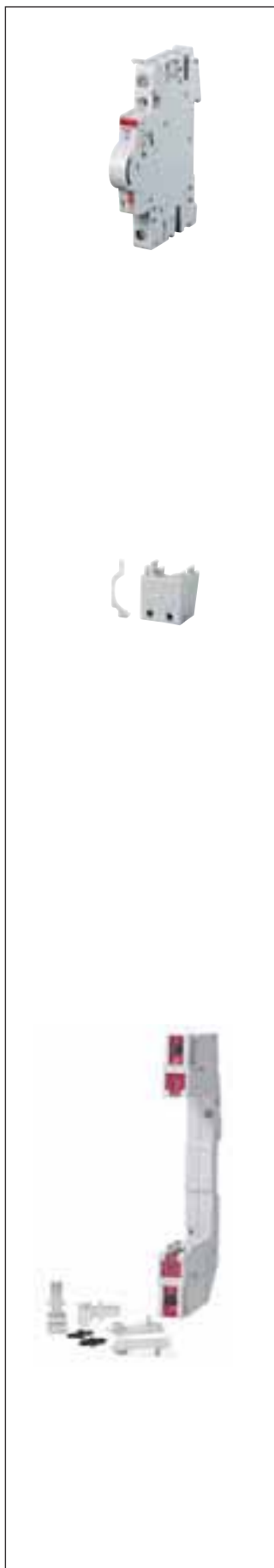
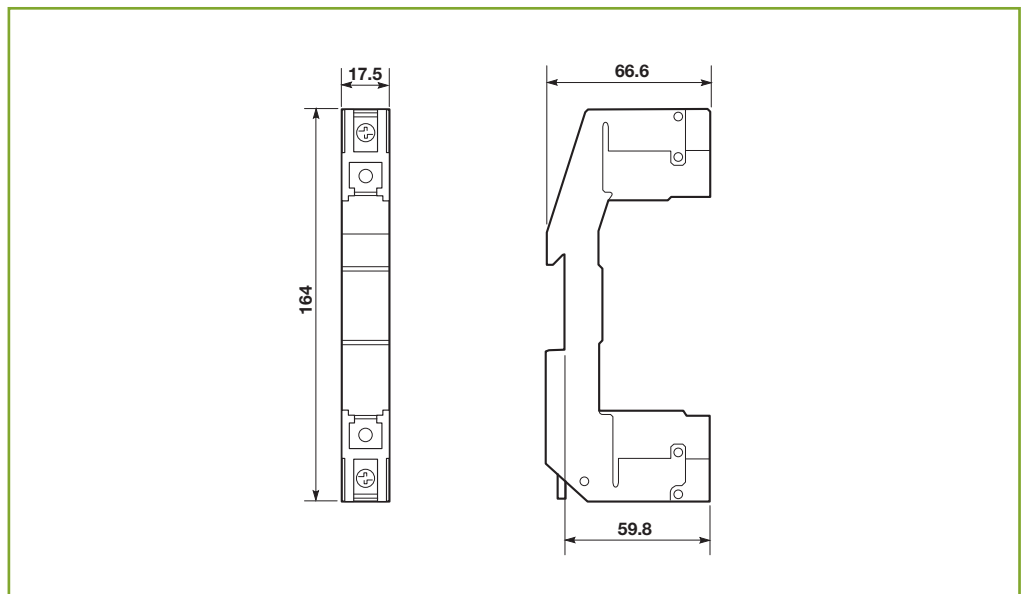



S 2C-BP

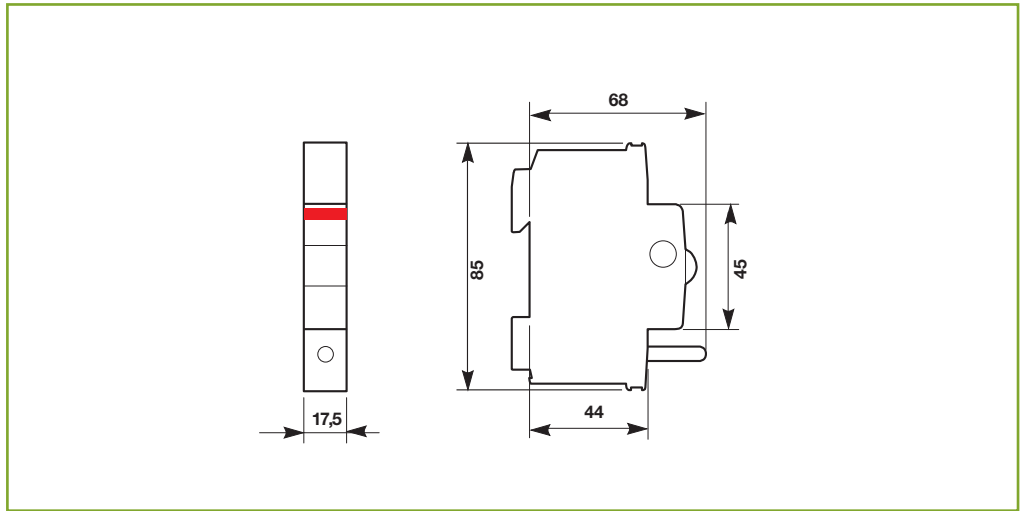

S 2C-CM

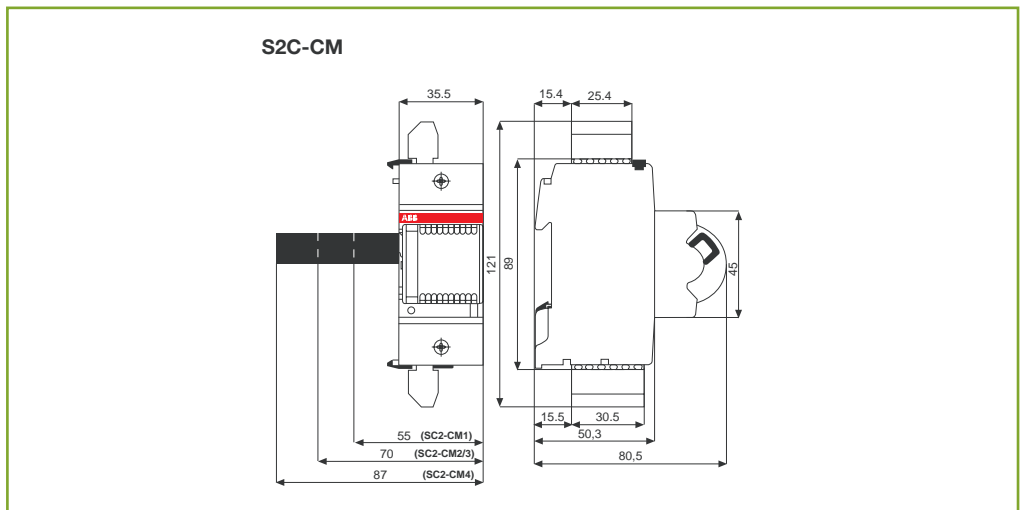

F 2C-ARI, F 2C-ARI30

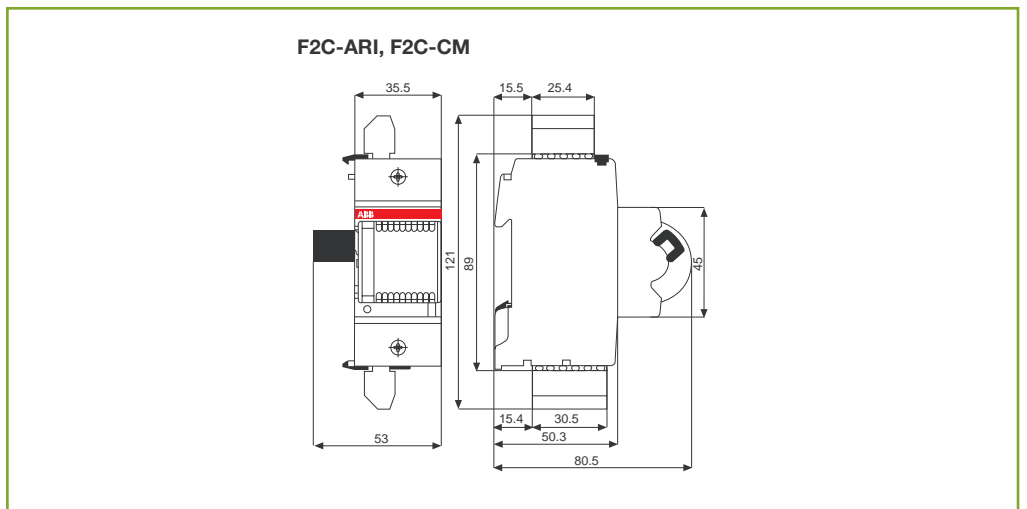

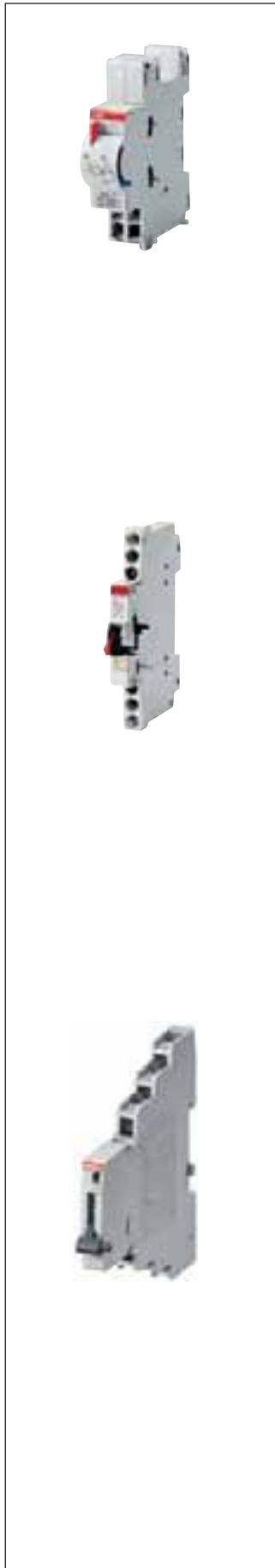

Auxiliary elements for S 9.. and DS 9.. series

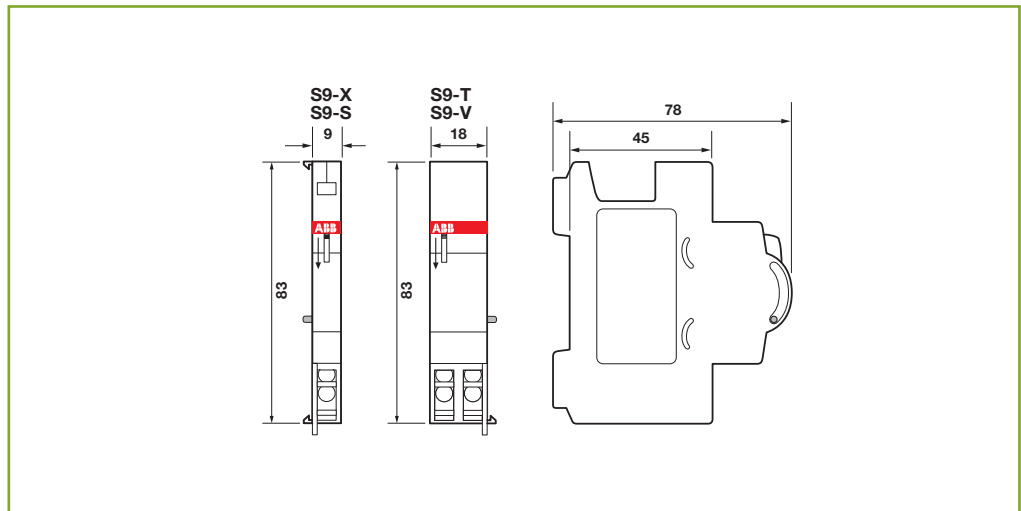

Auxiliary elements for S 280 and S 290 series

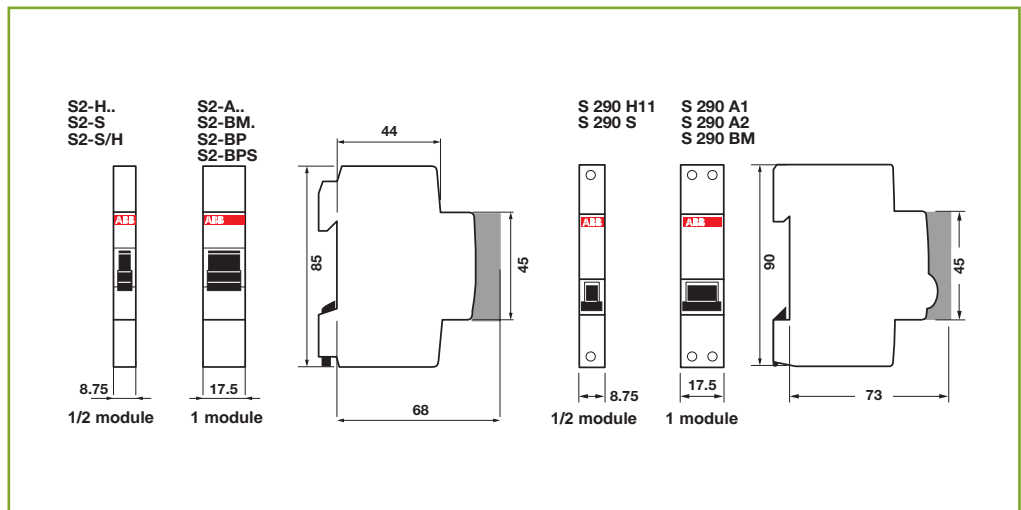

S 800-AUX, S 800-AUX/ALT

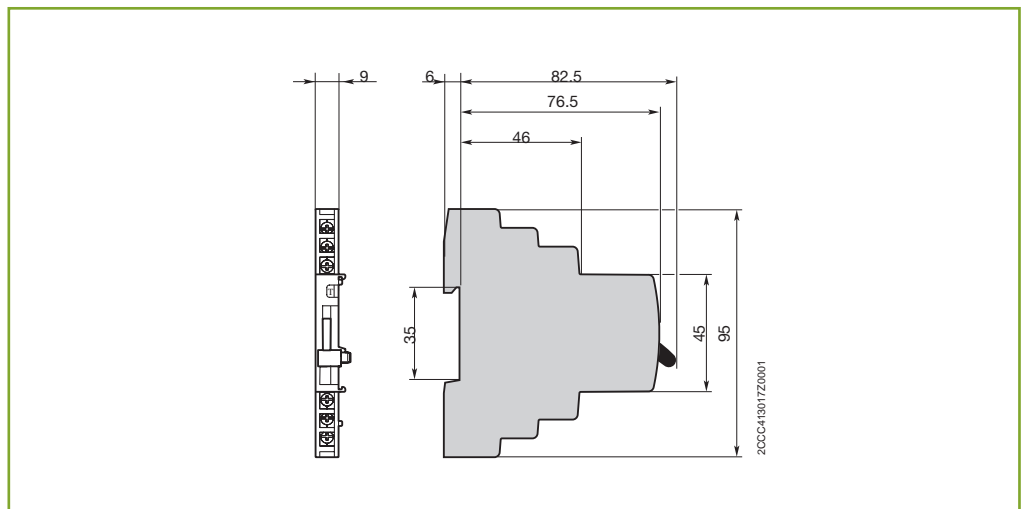

S 800-RD+S 800-RHE, S 800-NT, S 800-BB250, S 800-BBPC120

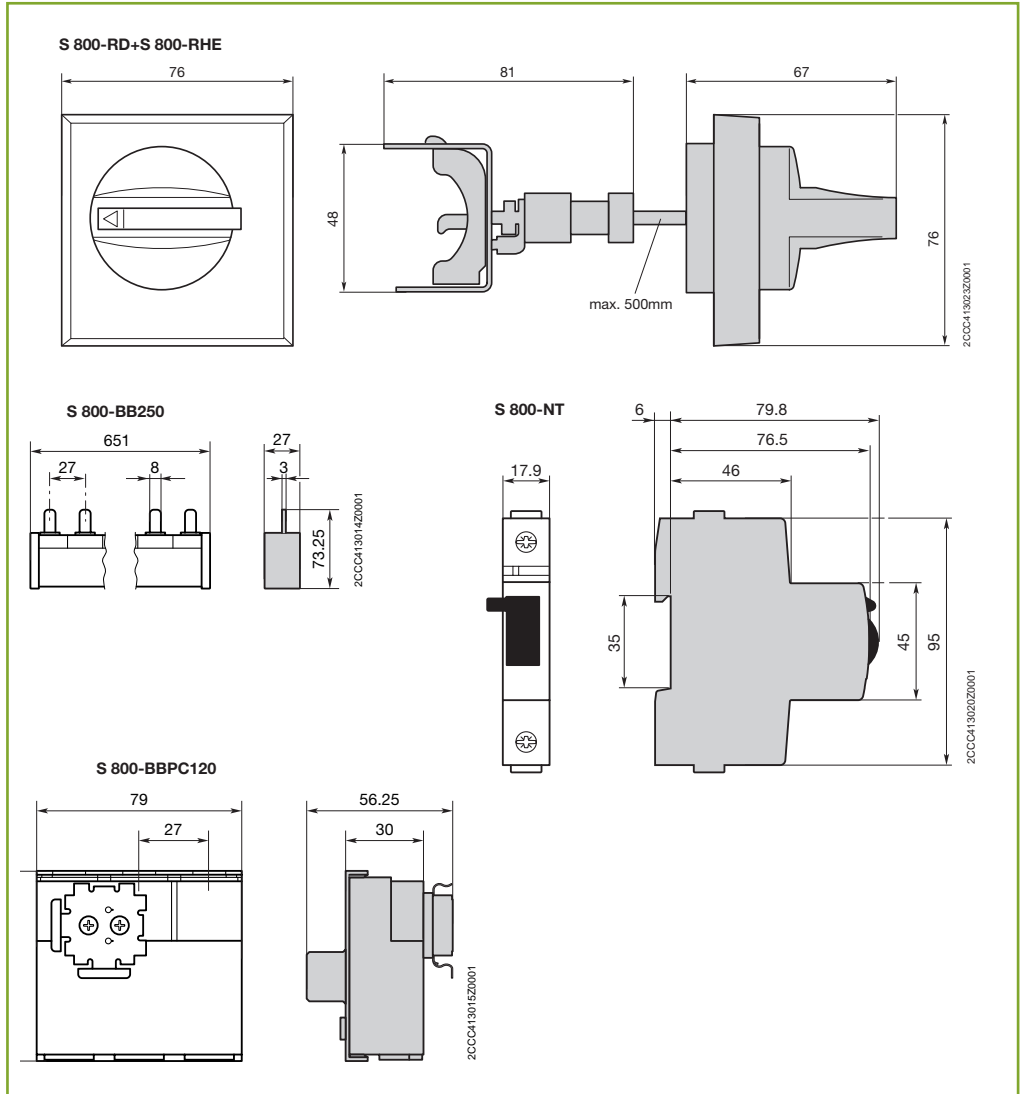

Terminal covers

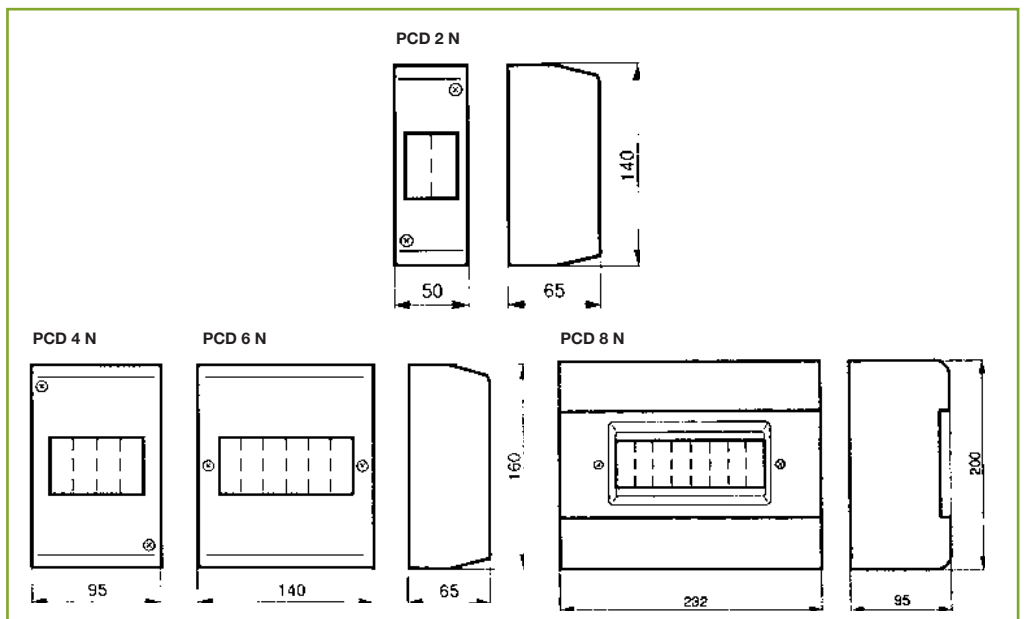

Enclosures of moulded-plastic

N + PE common terminals for QES

SMO 4

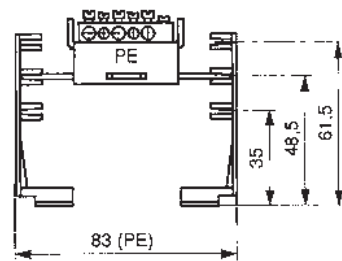

SMO 6

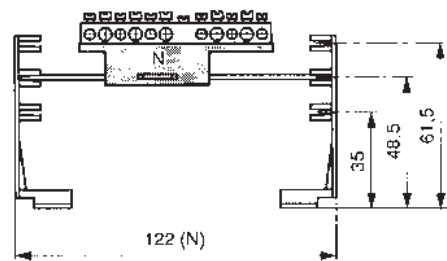
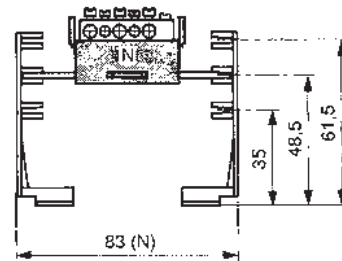
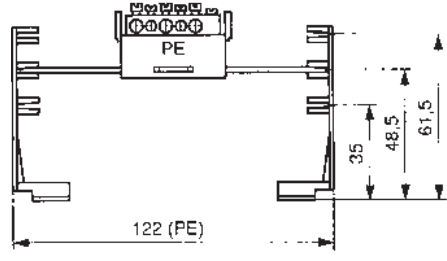

SMO 10

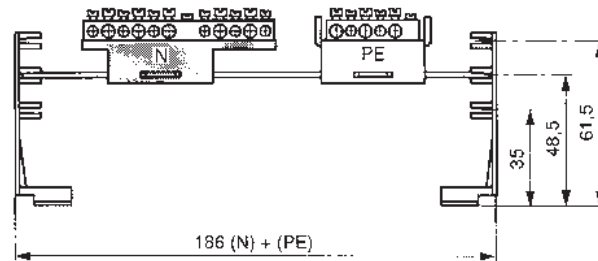

QES 10/3 N

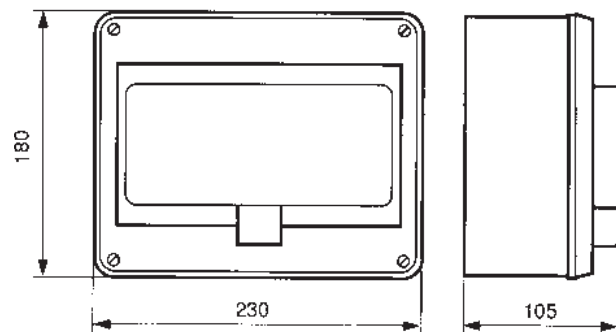

Flush frame

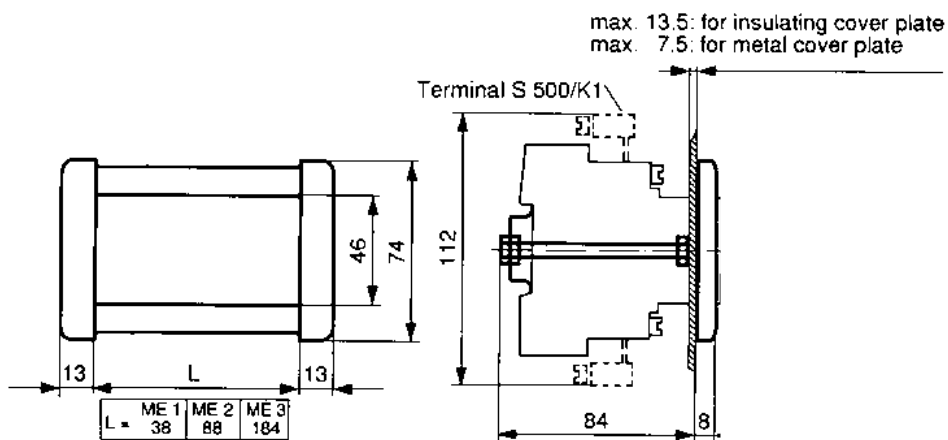

Type	Dim. L	Max. No. of modules (1 module=17.5 mm)
S 500 - ME 1	38 mm	for 2 module
S 500 - ME 2	88 mm	for 5 module
S 500 - ME 3	184 mm	for 10 module

Drill holes

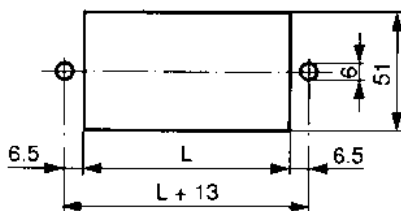

Mounting rails

① In the case of DSW 1, the drill holes are vertical

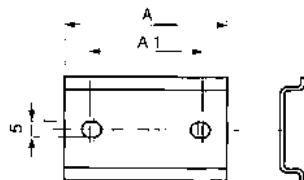

Name	A	A1
DSW	17.5	15
DSW 2	35	20
DSW 3	52.5	37.5
DSW 4	70	55
DSW 6	105	90

Busbars



PS 1/2

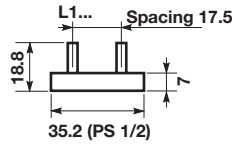

PS 1/6

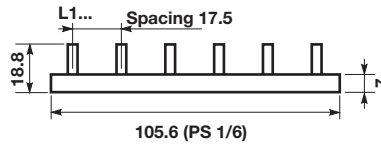

PS 1/9

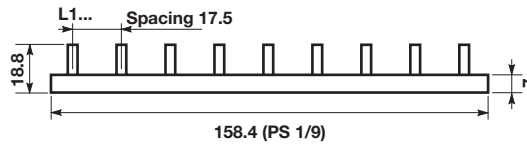

PS 1/12

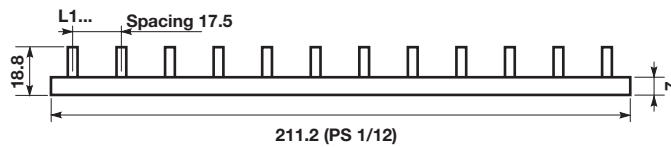

PS 3/60

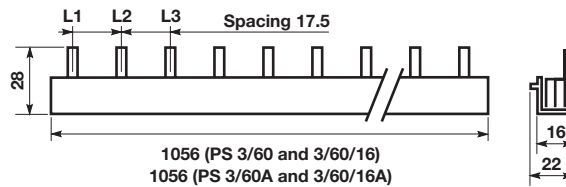

Auxiliary contact
bridge HKB

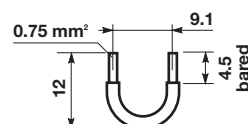

PS 3/6



PS 3/9

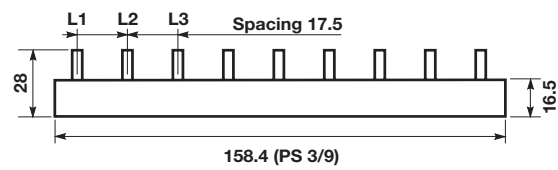

PS 3/12 (2CDL 230 001 R1012)

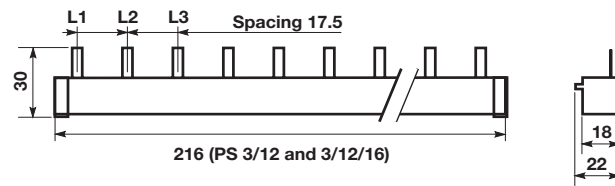

PS 3/12 FI (2CDL 230 002 R1012)

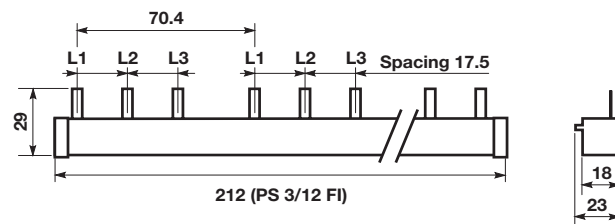

PS 2/12

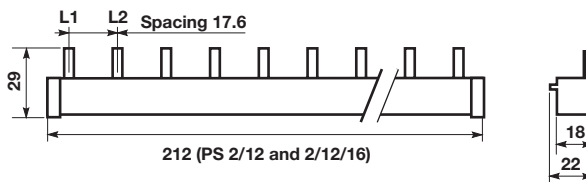

PS 2/58

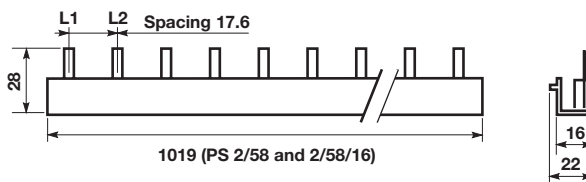

PS 2/48

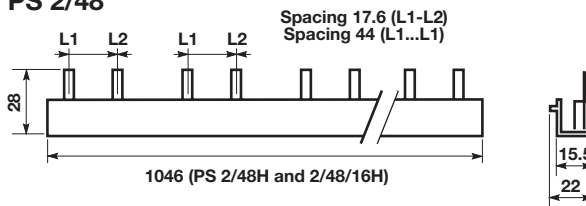

PS 3/39H

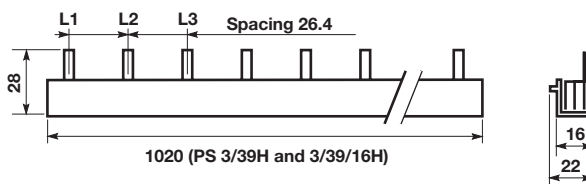

PS 3/48H

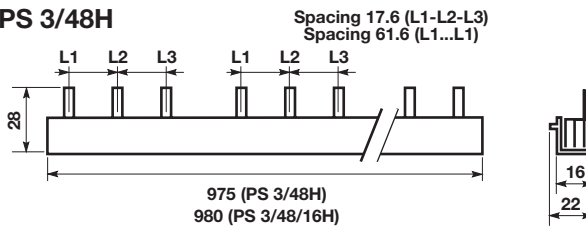

PS 3/12 FI H

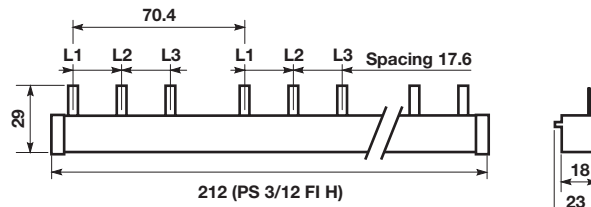

PS 4/12

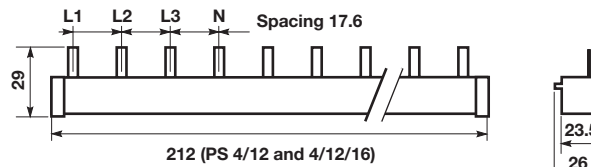

PS 4/60

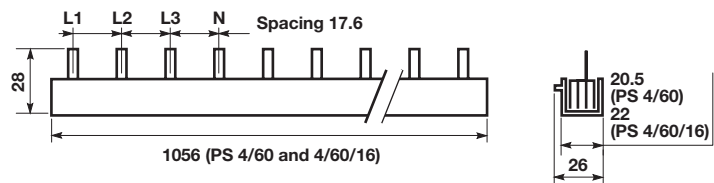

PS 4/58 N

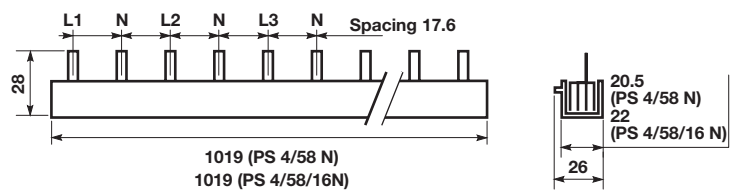

PS 3/12 E 463

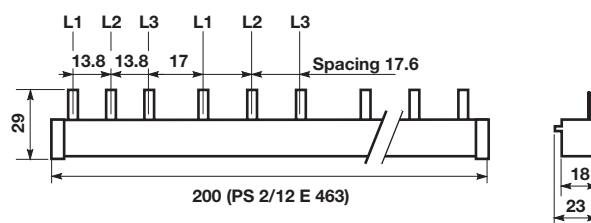

ME flange for rear board mounting

DEPTH D
57 mm for S 240-S 250-
S 270-S 280 circuit-breakers
72 mm for S 210 circuit-breakers

TYPE	A	B	C
ME 1 - 1 module	18	40	50
ME 2 - 2 modules	36	57.5	67
ME 3 - 3 modules	54	75.5	85
ME 4 - 4 modules	72	93	103
ME 6 - 6 modules	108	129	139
ME 8 - 8 modules	144	164	172

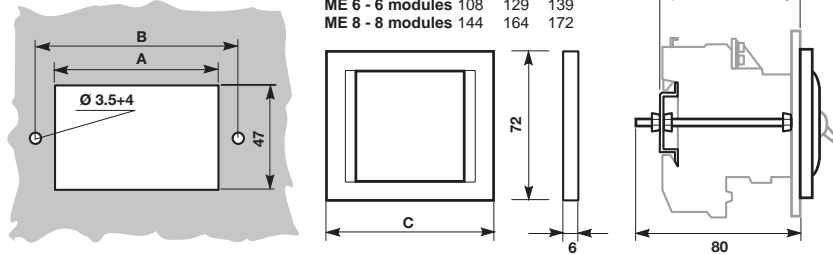

OH_2A

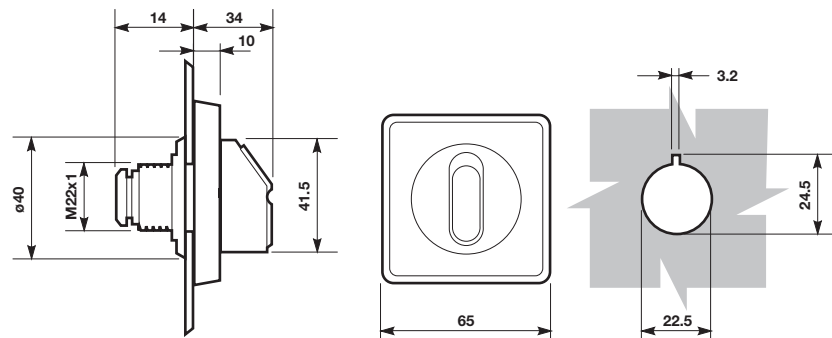



Type 1 Surge Protective Devices

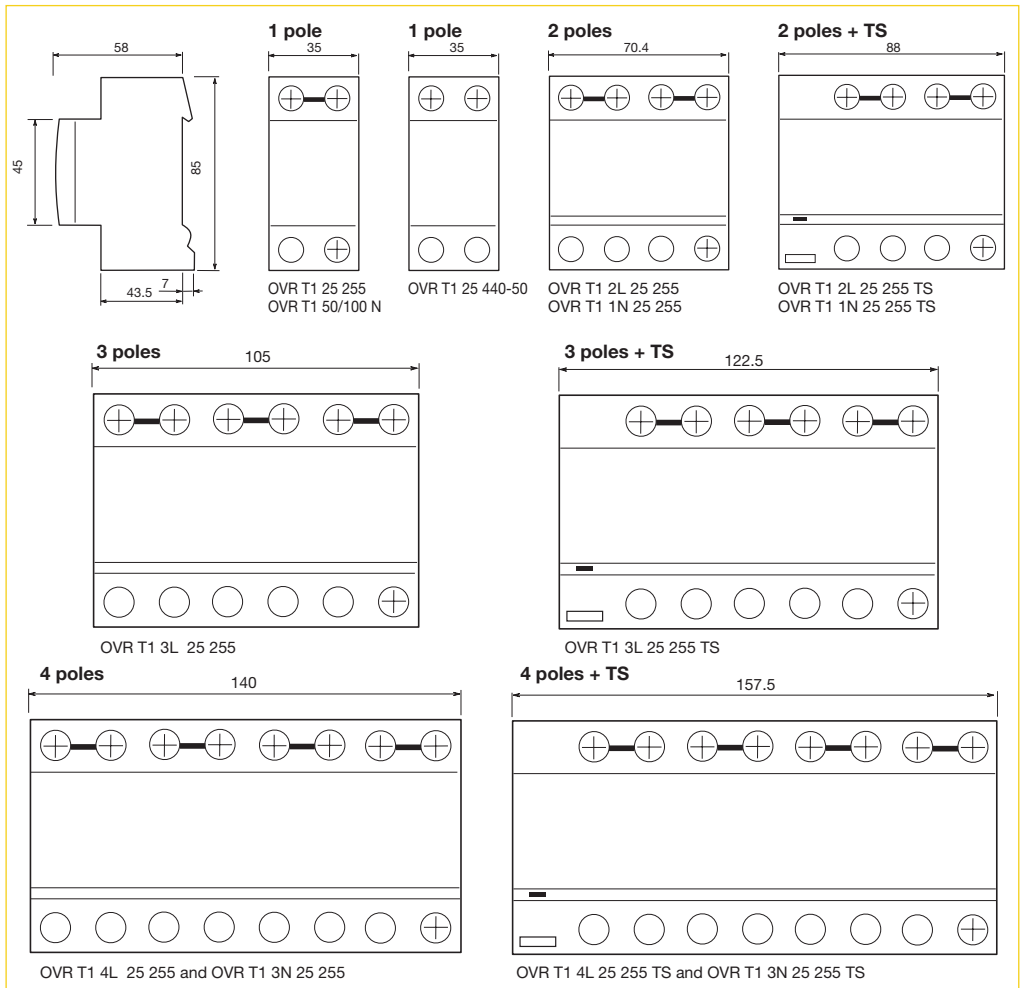

Type 1+2 Surge Protective Devices

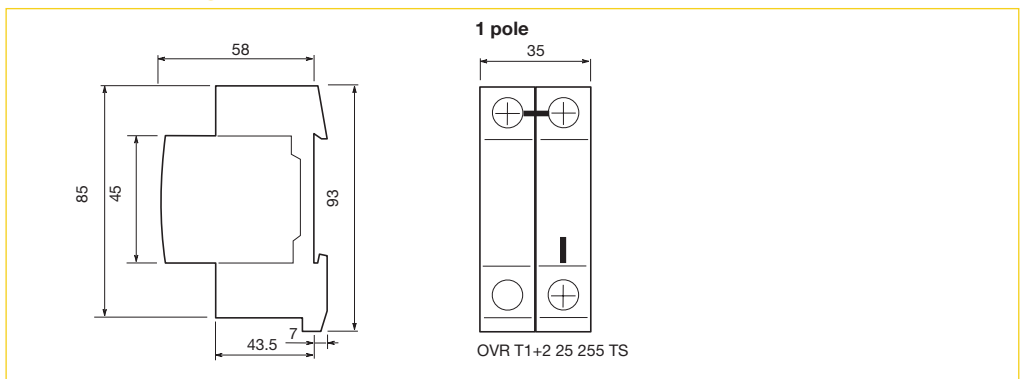

Type 1 & Type 1+2 Surge Protective Devices

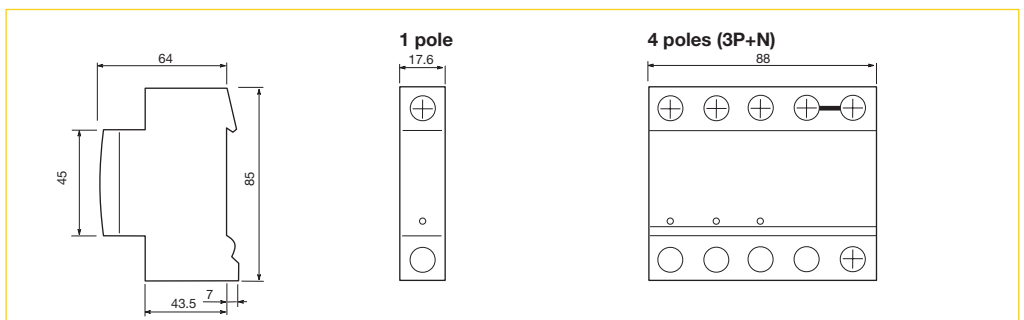

Type 1 + 2 / Type 2 Surge Protective Devices

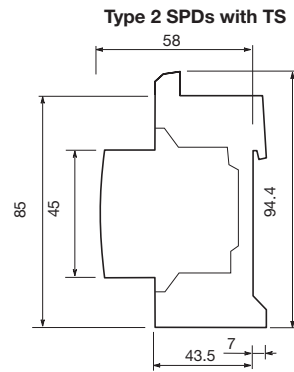
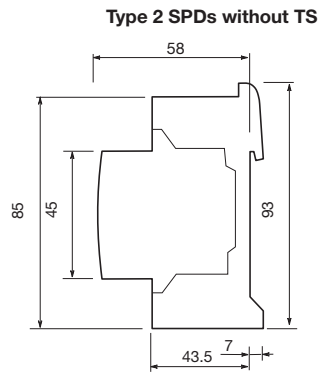

1 pole



- OVR TC 6V P
- OVR TC 12V P
- OVR TC 24V P
- OVR TC 48V P
- OVR TC 200V P
- OVR TC 200FR P

1 pole



- OVR T2 15 275
- OVR T2 40 275
- OVR T2 15 275 P
- OVR T2 40 275 P
- OVR T2 40 275s P TS
- OVR T2 70 275s P TS
- OVR T2 15 440 P
- OVR T2 40 440 P
- OVR T2 40 440s P TS
- OVR T2 70 440s P TS
- OVR T1+2 7 275s P

2 poles (1P+N)

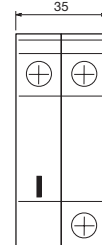

- OVR T2 1N 15 275 P
- OVR T2 1N 40 275 P
- OVR T2 1N 40 275s P TS
- OVR T2 1N 70 275s P TS
- OVR T1+2 1N 7 275s P

3 poles

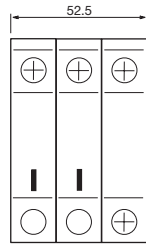

- OVR PV 40 600 P
- OVR PV 40 600 P TS

3 poles

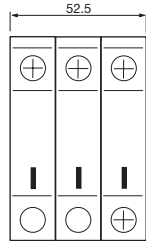

- OVR T2 3L 15 275 P
- OVR T2 3L 40 275 P
- OVR T2 3L 40 275s P TS
- OVR T2 3L 70 275s P TS
- OVR T2 3L 40 275
- OVR T1+2 3L 7 275s P
- OVR PV 40 1000 P
- OVR PV 40 1000 P TS

4 poles (4P+0)

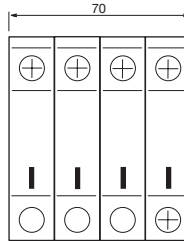

- OVR T2 4L 15 275 P
- OVR T2 4L 40 275 P
- OVR T2 4L 40 275s P TS
- OVR T2 4L 70 275s P TS
- OVR T2 4L 40 275
- OVR T1+2 4L 7 275s P

3 poles (3P+N)

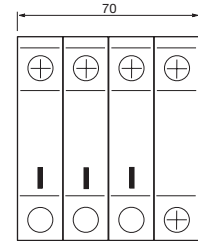

- OVR T2 3N 15 275 P
- OVR T2 3N 40 275 P
- OVR T2 3N 40 275s P TS
- OVR T2 3N 70 275s P TS
- OVR T2 3N 40 275
- OVR T1+2 7 275s P

RD2 residual current monitors and toroidal transformers

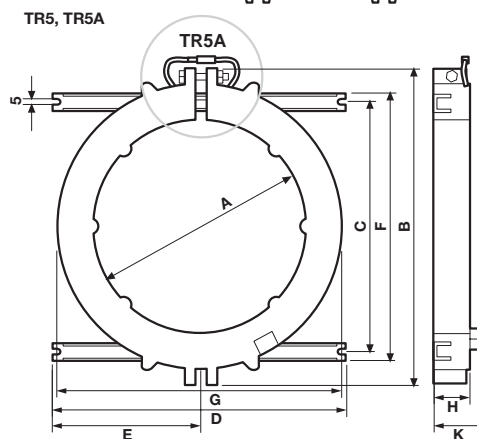
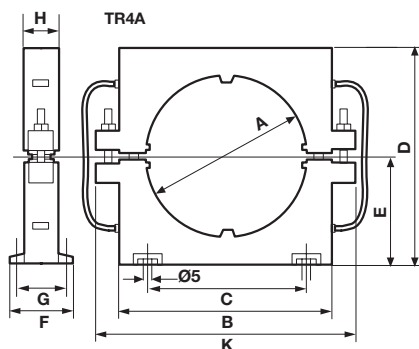
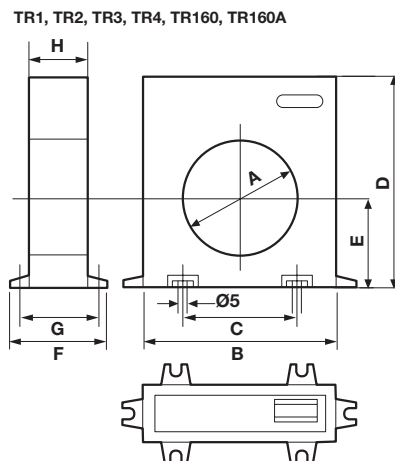
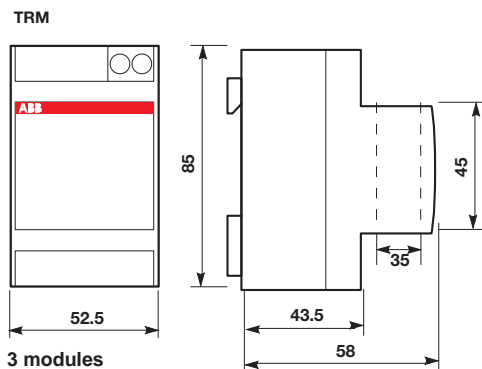
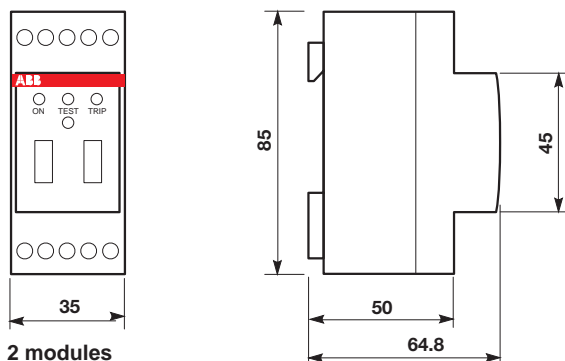

Type	Dimensions (mm)								
	A	B	C	D	E	F	G	H	K
TR1	35	100	60	110	47	50	43	30	-
TR2	60	100	60	110	47	50	43	30	-
TR3	80	150	110	160	70	50	43	30	-
TR4	110	150	110	160	70	50	43	30	-
TR4A	110	145	110	150	75	45	38	25	180
TR160	160	220	156	236	110	64	50	34	-
TR160A	160	220	156	236	110	64	50	34	-
TR5	210	310	240	290	145	260	280	36	55
TR5A	210	310	240	290	145	260	280	36	55



E 930 fuse holders

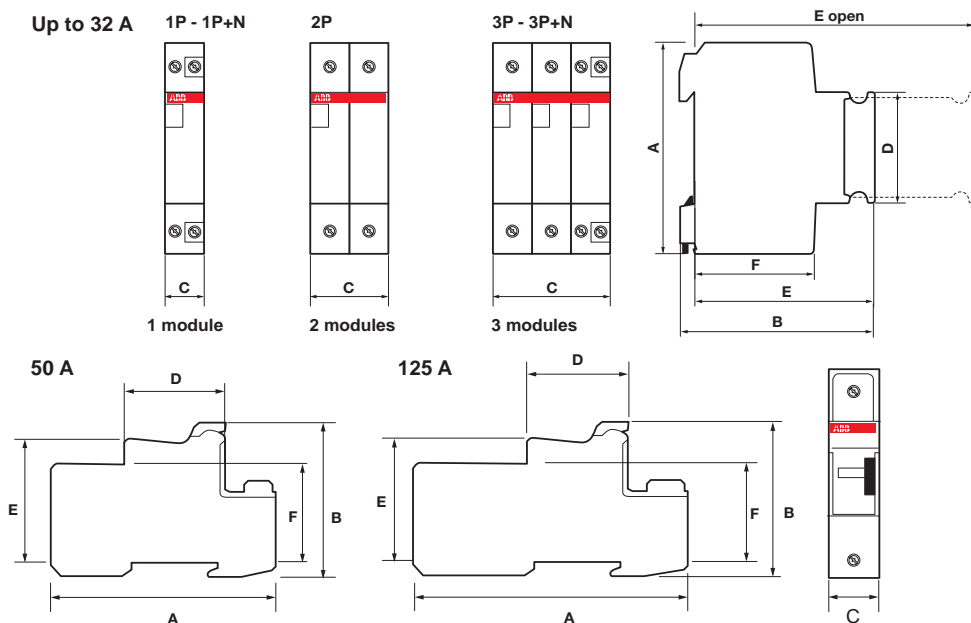

Type	No. poles	Dimensions of fuse	A	B/B open	C	D	E/E open	F
E 931/20-32	1	8.5x31.5 (32 A: 10.3x38)	83	72/117	17.5	45	66/111	44
E 931N/20-32	1+N	8.5x31.5 (32 A: 10.3x38)	83	72/117	17.5	45	66/111	44
E 932/20-32	2	8.5x31.5 (32 A: 10.3x38)	83	72/117	35	45	66/111	44
E 933/20-32	3	8.5x31.5 (32 A: 10.3x38)	83	72/117	52.5	45	66/111	44
E 933N/20-32	3+N	8.5x31.5 (32 A: 10.3x38)	83	72/117	52.5	45	66/111	44
<hr/>								
E 931/50	1	14x51	107	76.5/101.5	26.5	45	60	50
E 931N/50	1+N	14x51	107	76.5/101.5	53	45	60	50
E 932/50	2	14x51	107	76.5/101.5	53	45	60	50
E 933/50	3	14x51	107	76.5/101.5	79.5	45	60	50
E 933N/50	3+N	14x51	107	76.5/101.5	106	45	60	50
<hr/>								
E 931/125	1	22x58	126.5	76.5/103.5	35	45	60	50
E 931N/125	1+N	22x58	126.5	76.5/103.5	70	45	60	50
E 932/125	2	22x58	126.5	76.5/103.5	70	45	60	50
E 933/125	3	22x58	126.5	76.5/103.5	105	45	60	50
E 933N/125	3+N	22x58	126.5	76.5/103.5	140	45	60	50



M2160 - M2060 fuse switches

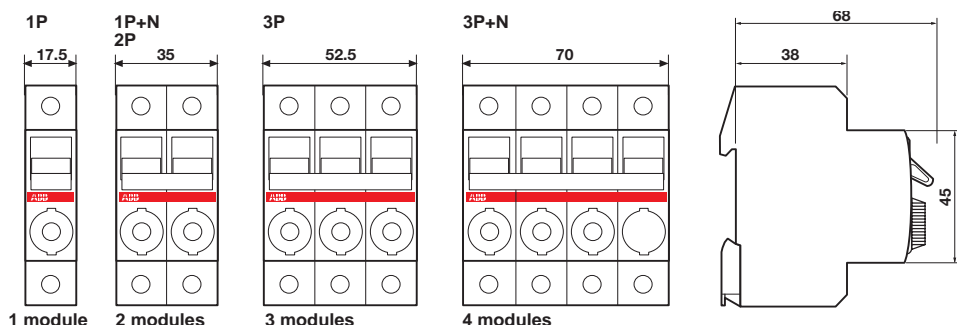



E 259 installation relays

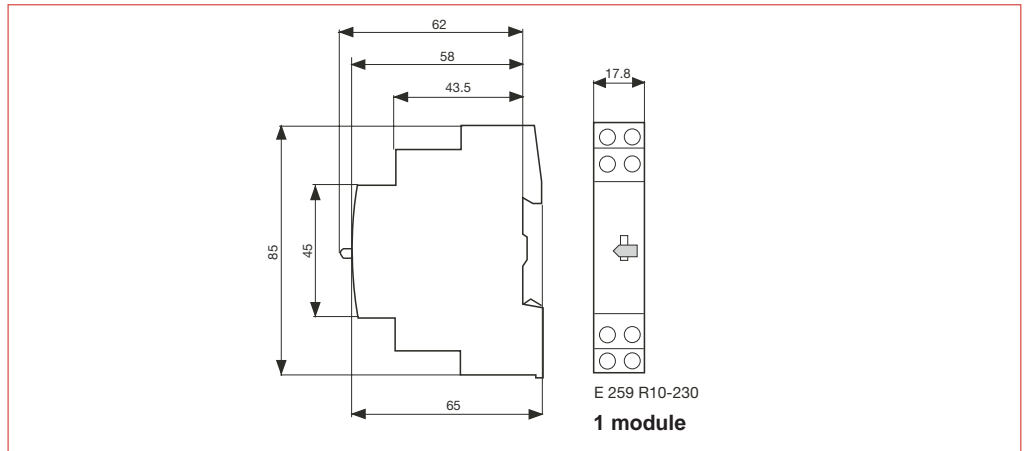

E 200 switches

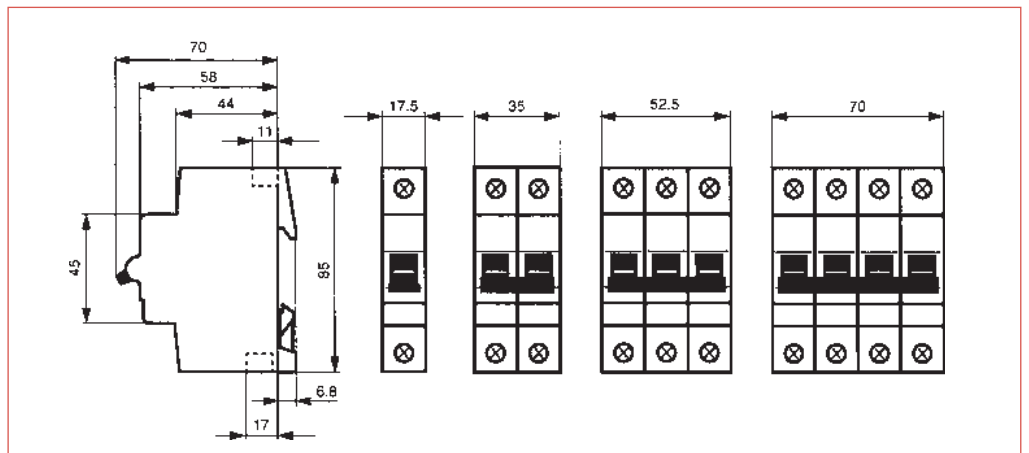

E 463/3-KB, E 480/-KB, E 463/3-SL switches

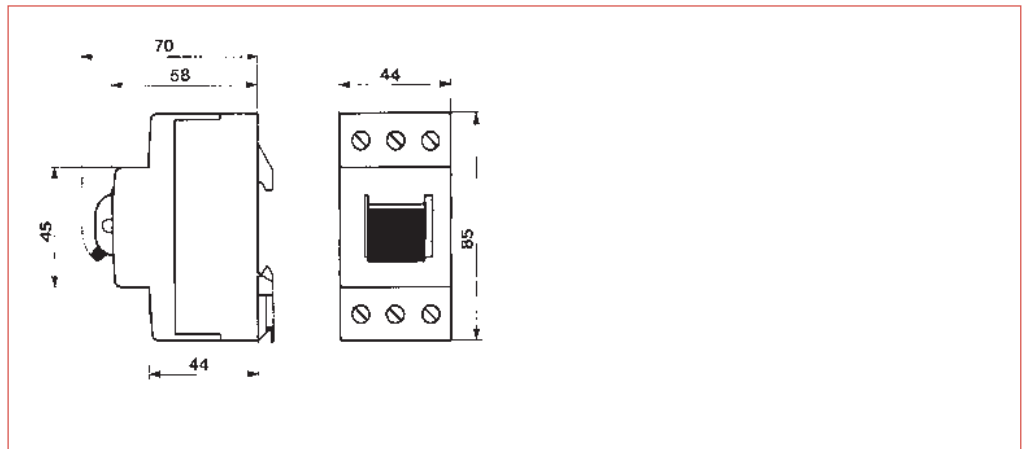



E 250 latching relays

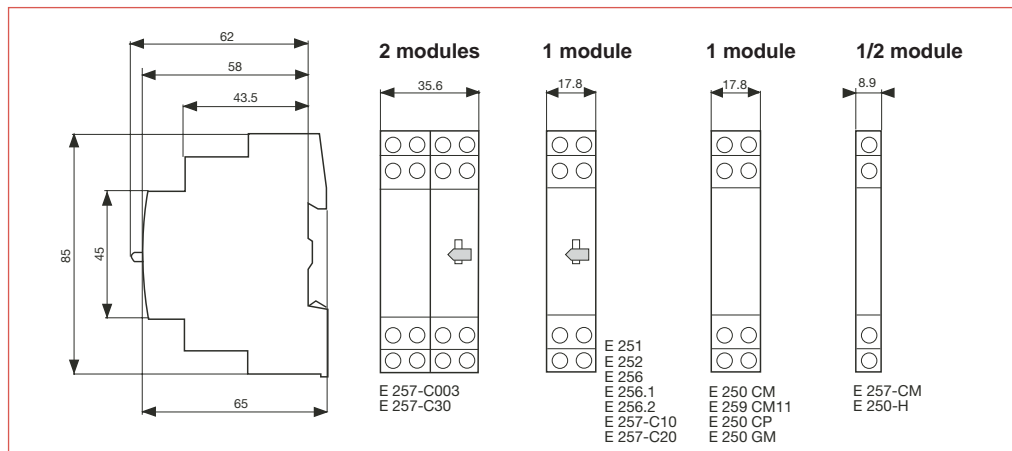

E 260 latching relays

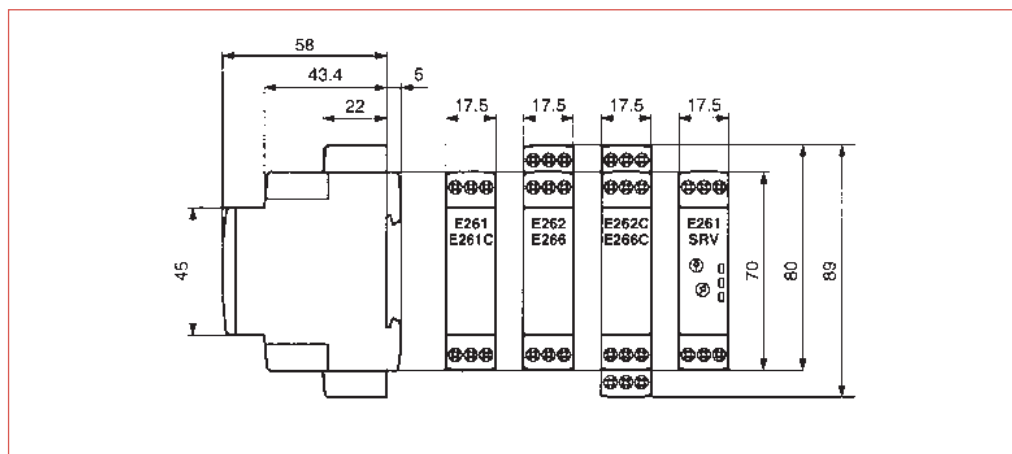

E 220 switches

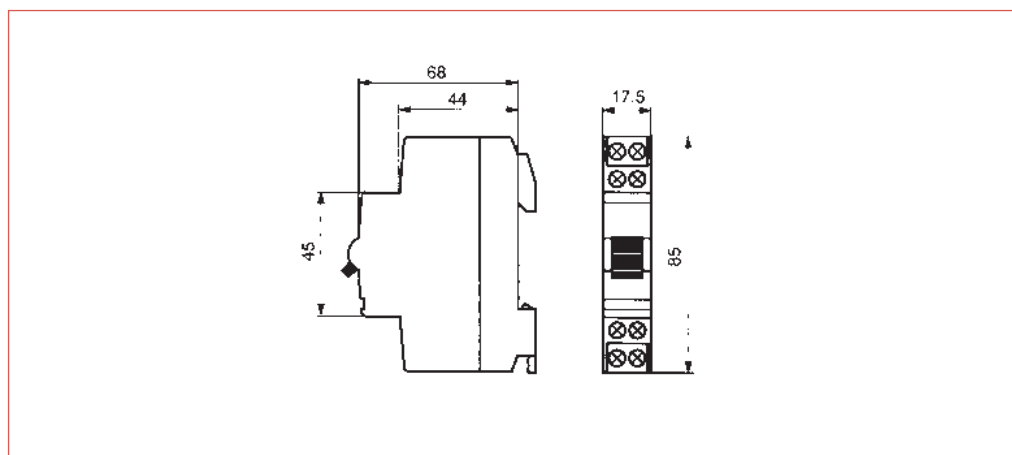



E 220 pushbuttons and indicator lamps

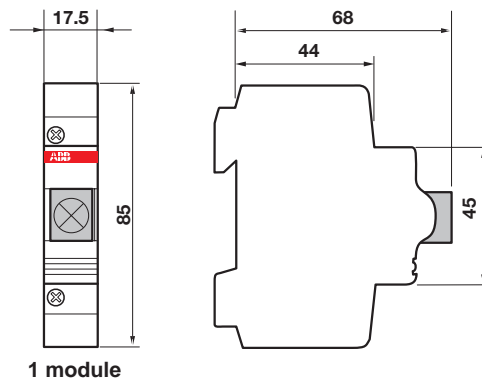

ESB/EN contactors

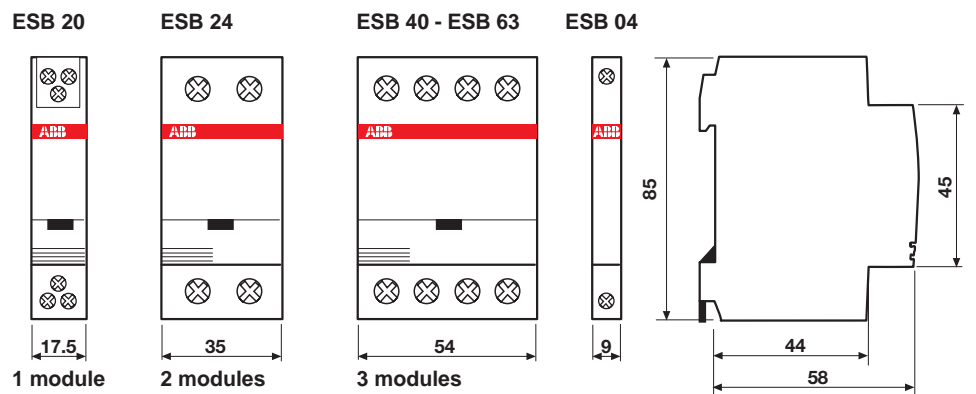

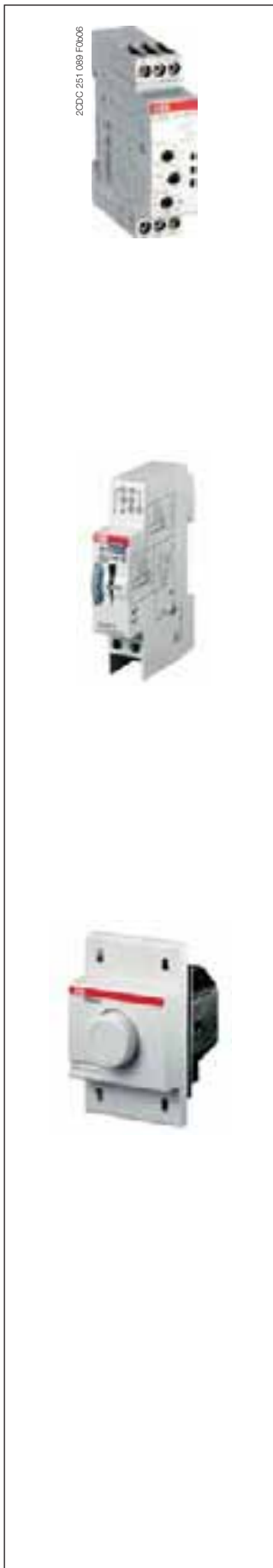

E 234 CT-D electronic timers

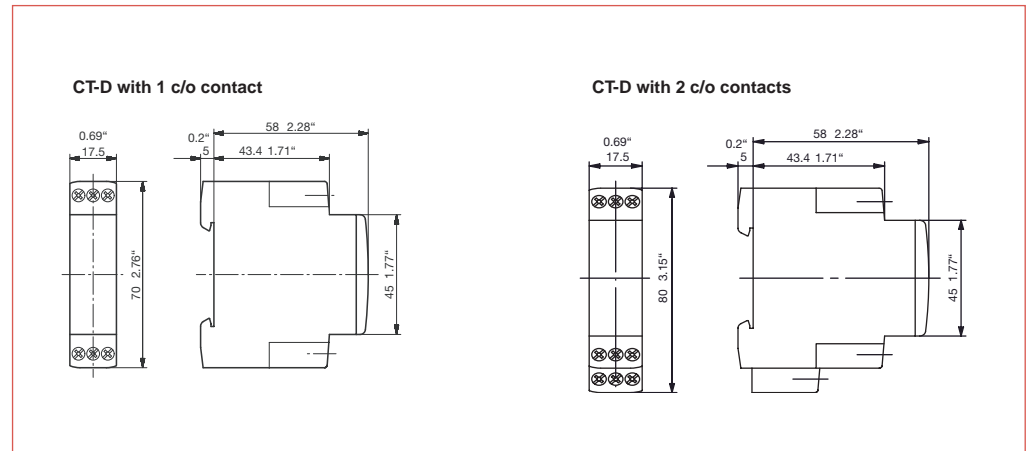

E 232 staircase lighting time delay relays

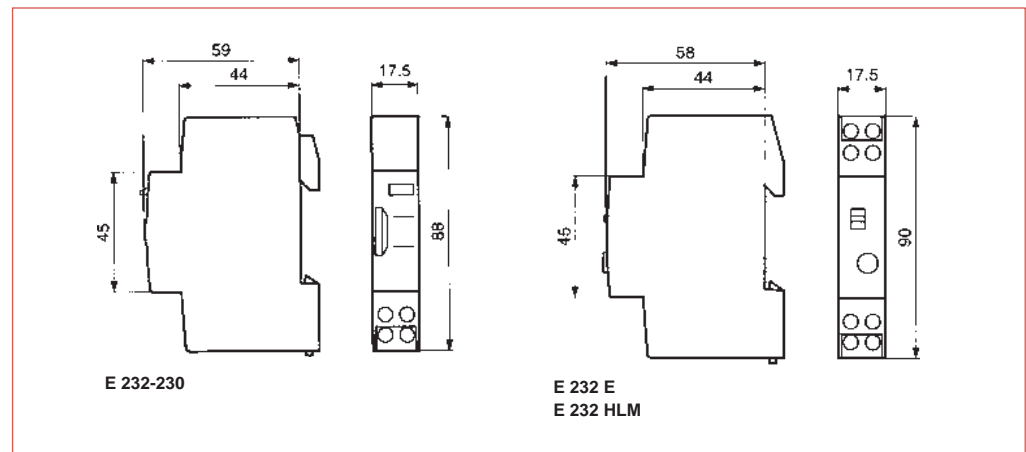

STD dimmers

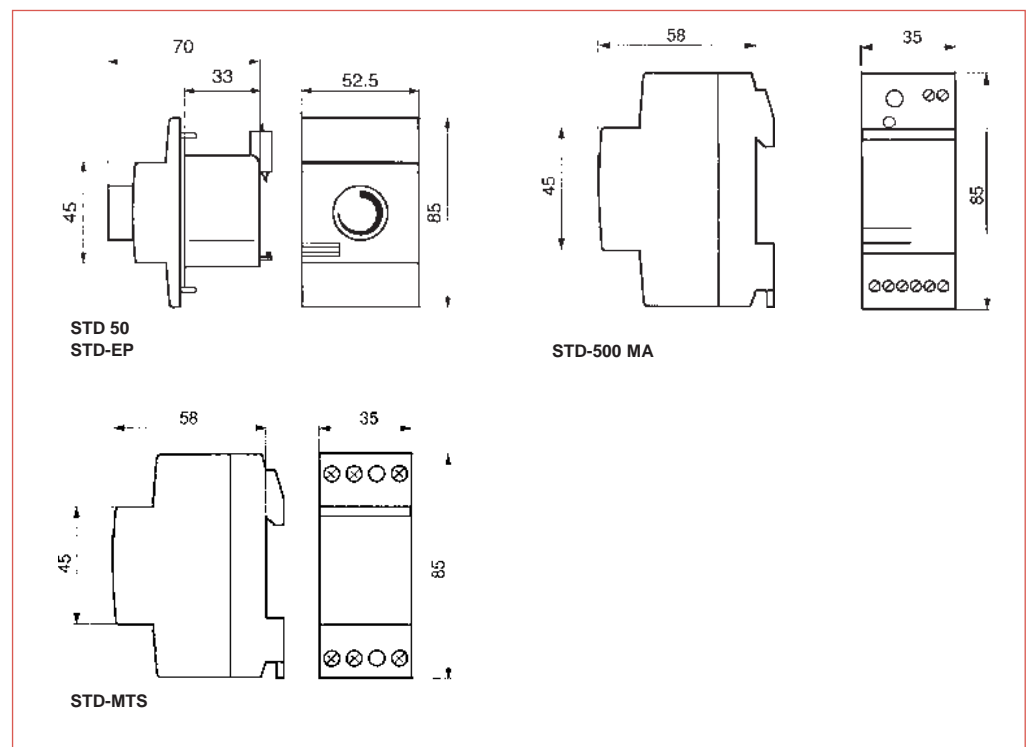



AT electro-mechanical time switches

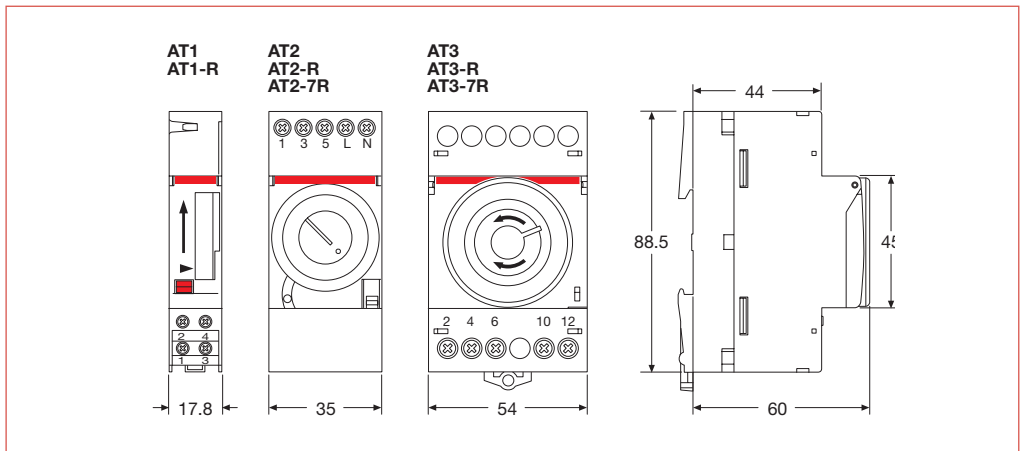

DT digital time switches

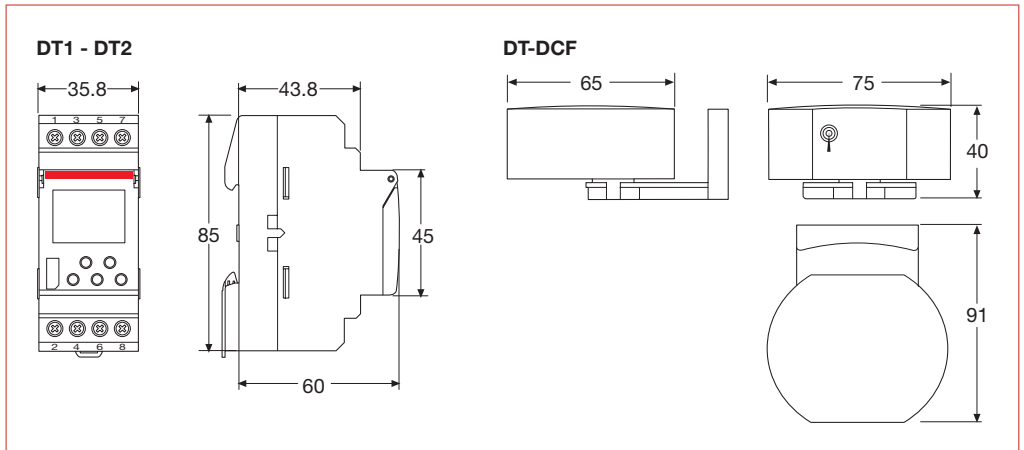

2CDC 311 034 F0606



CL logic relays

CL-LSR, CL-LST

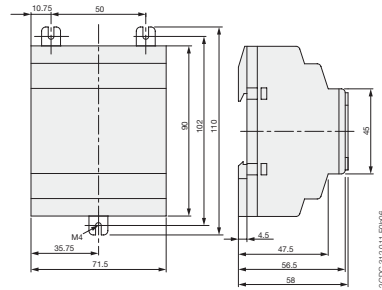

CL-LMR, CL-LMT

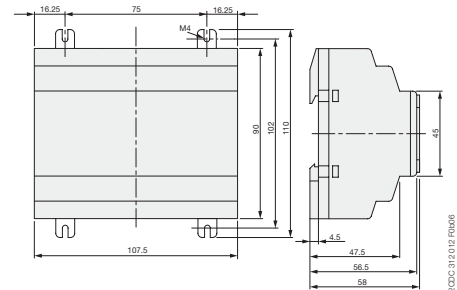

CL-LER.20

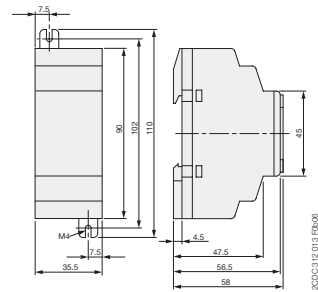

CL-LDD.K + CL-LDC.L. +
(CL-LDR or CL-LDT)

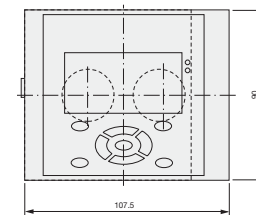

CL-LDD

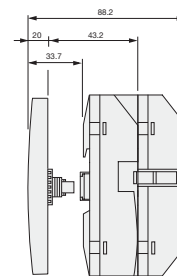
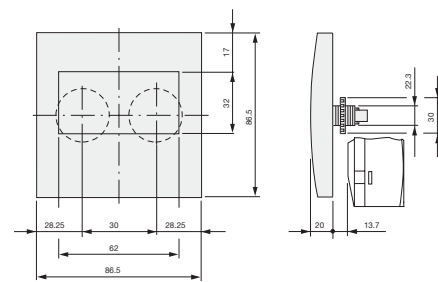

CL-LDR, CL-LDT

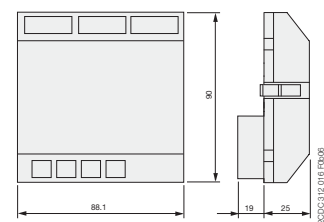

CL-LDC.S..

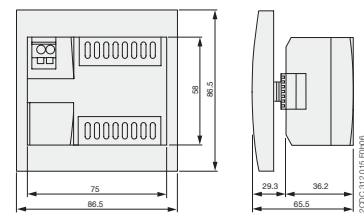



E 450 priority switches

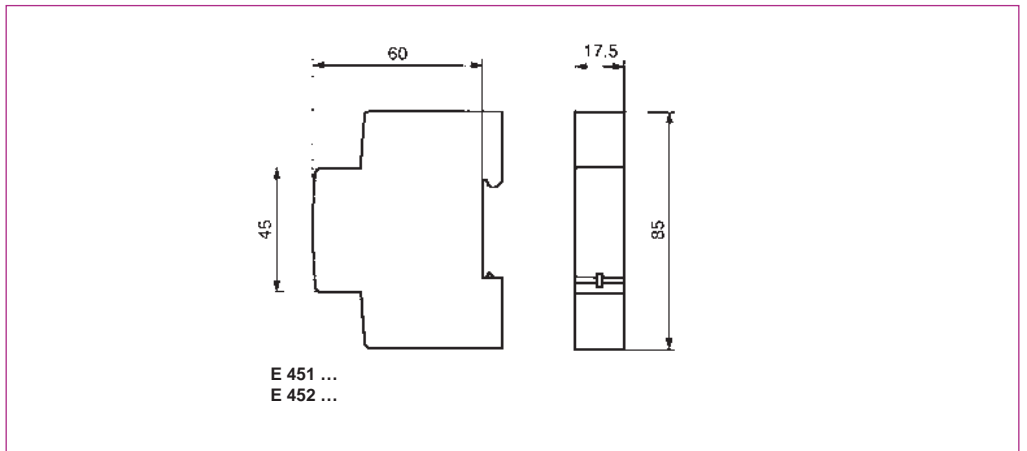

TW twilight switches

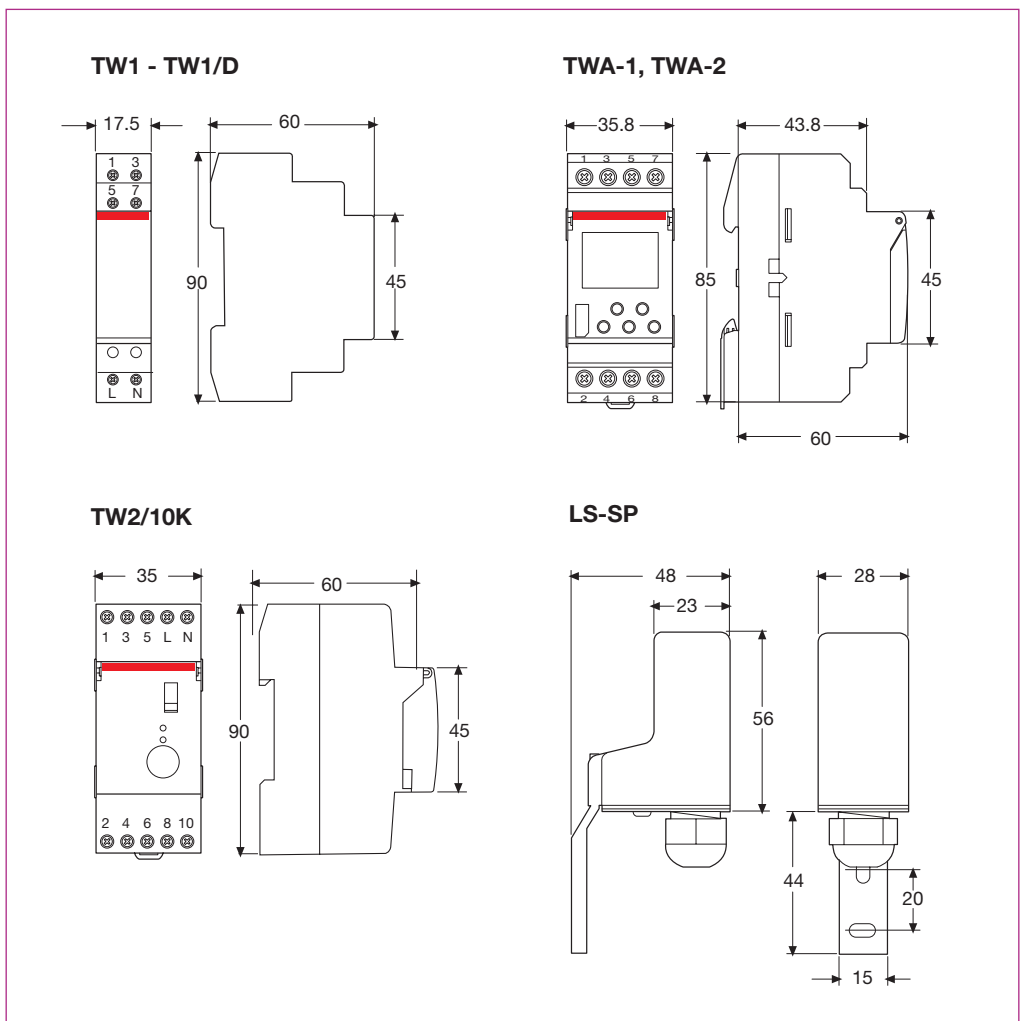



RAL overload alarms

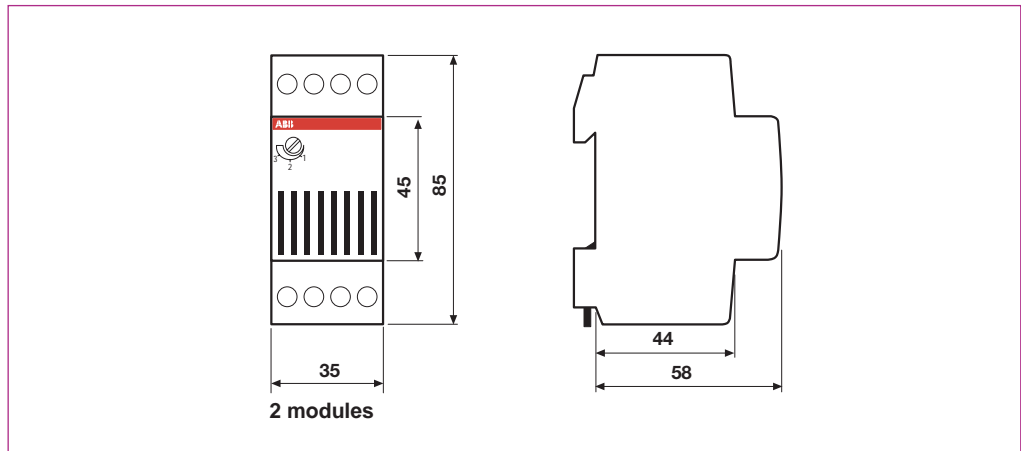

LSS1/2 load shedding switches

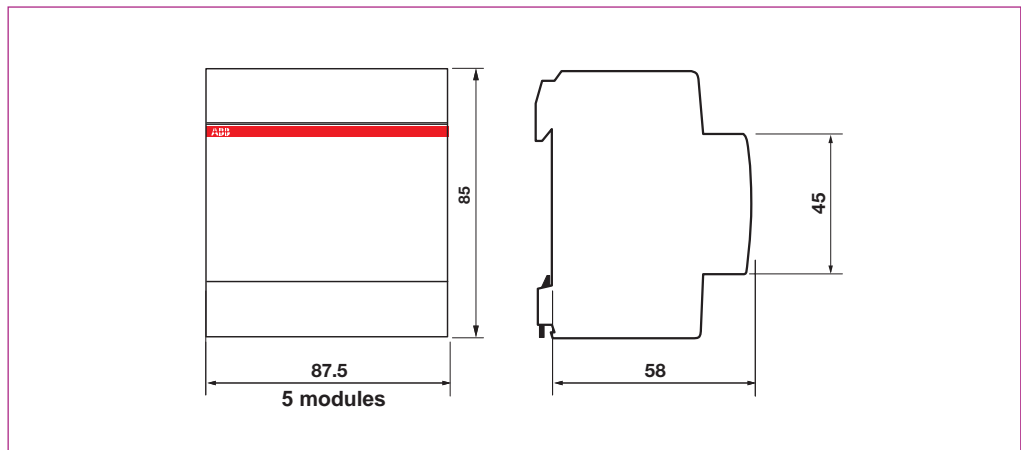



SQZ3 phase and sequence relays

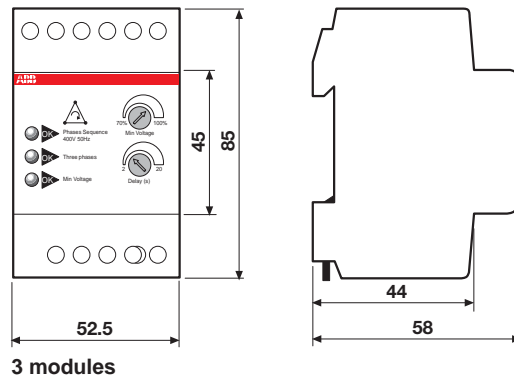

LEE 230 power failure signalling lamp

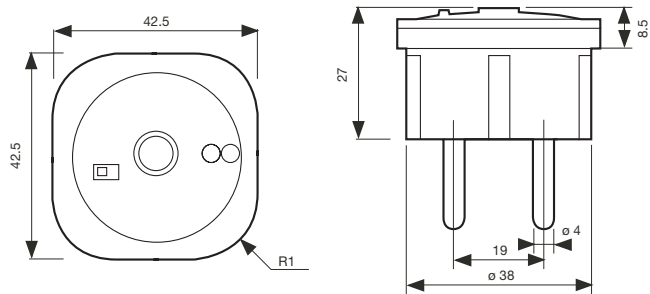

Max./min. current/voltage ammetric and voltmetric relays

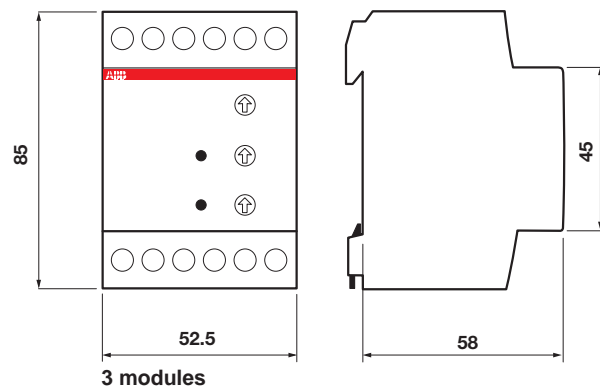



E 235 mains disconnection relays

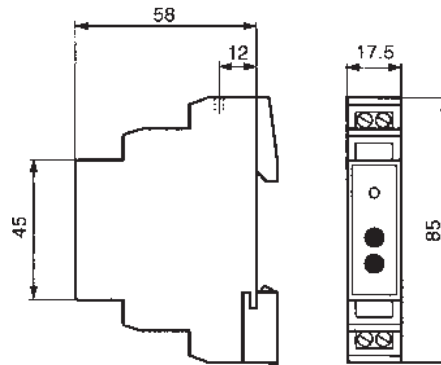

E 236 undervoltage monitoring relays

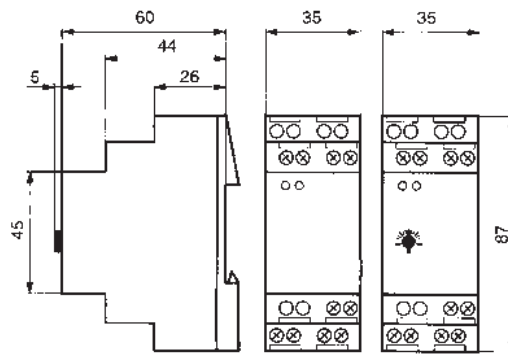



Analogue measurement instruments

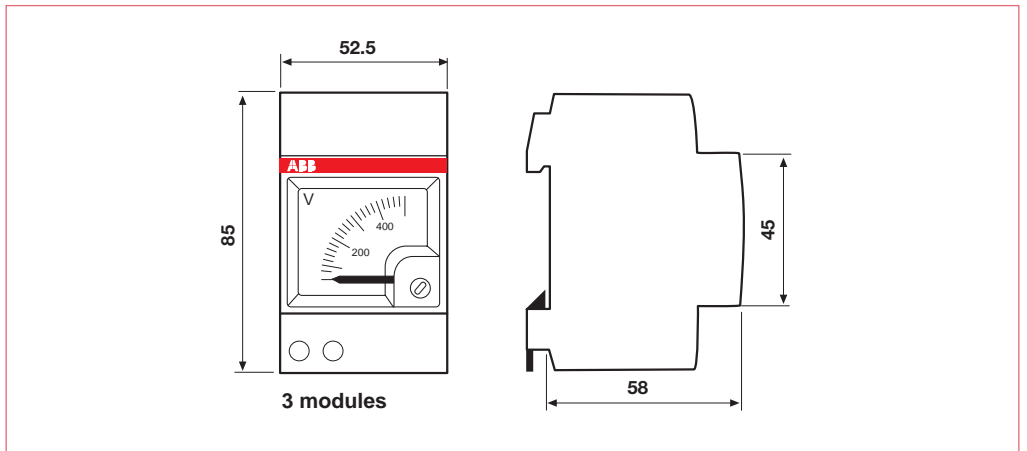

Digital measurement instruments (VLM-D, AMT-D)

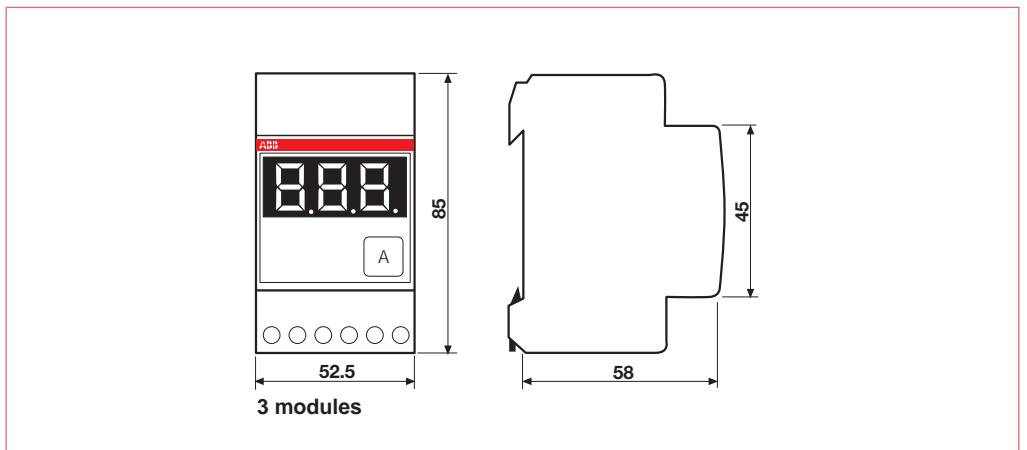



DMTME multimeters

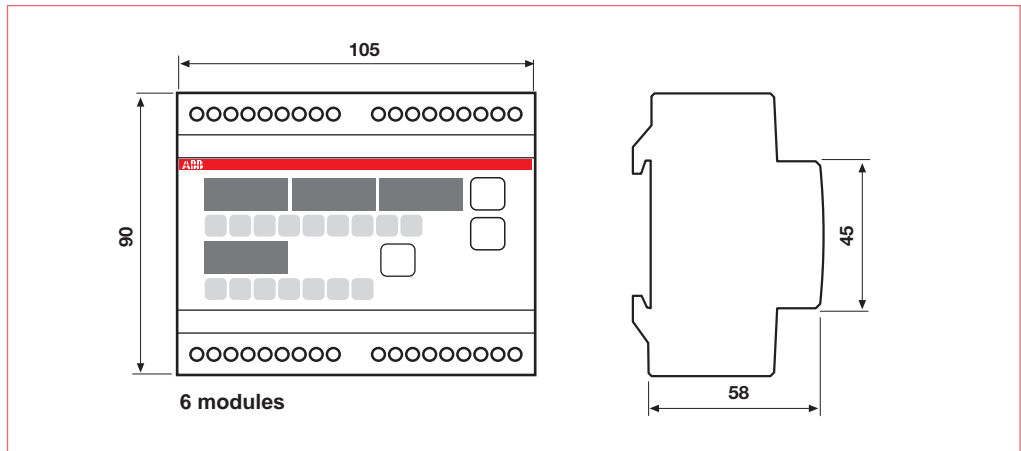

MCV - MCA voltmetric and ammetric switches

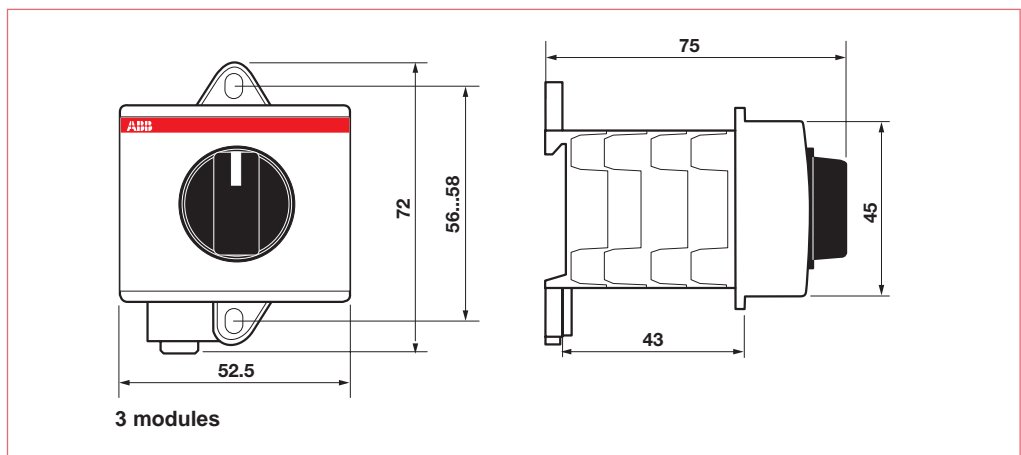

Standard type current transformers

CTA

From 1 to 40 A

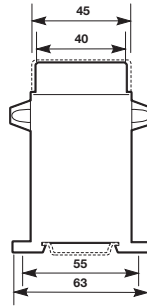
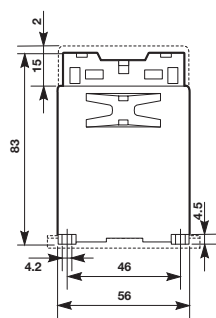

from 40 to 100 A

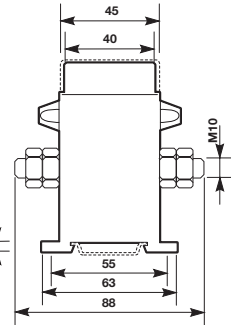
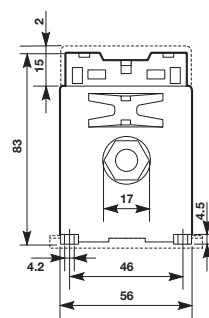

CTA1 and CTA2

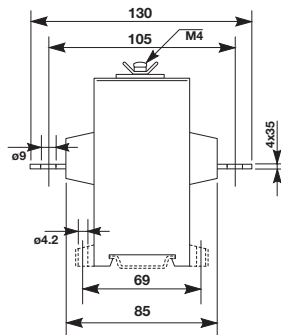
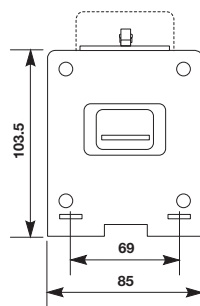

TRFM

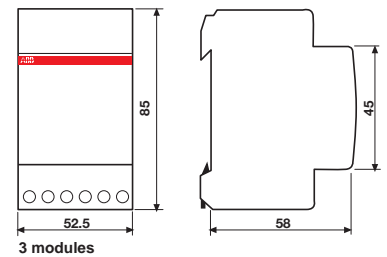

3 modules

CT3

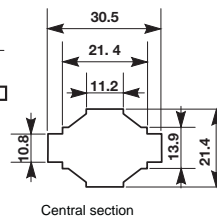
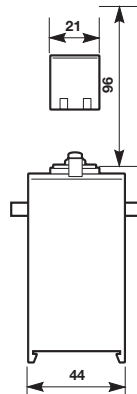
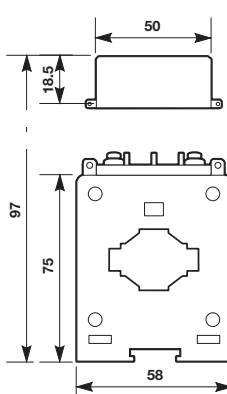

Central section

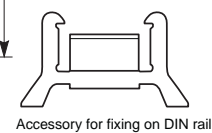
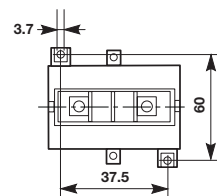

Accessory for fixing on DIN rail

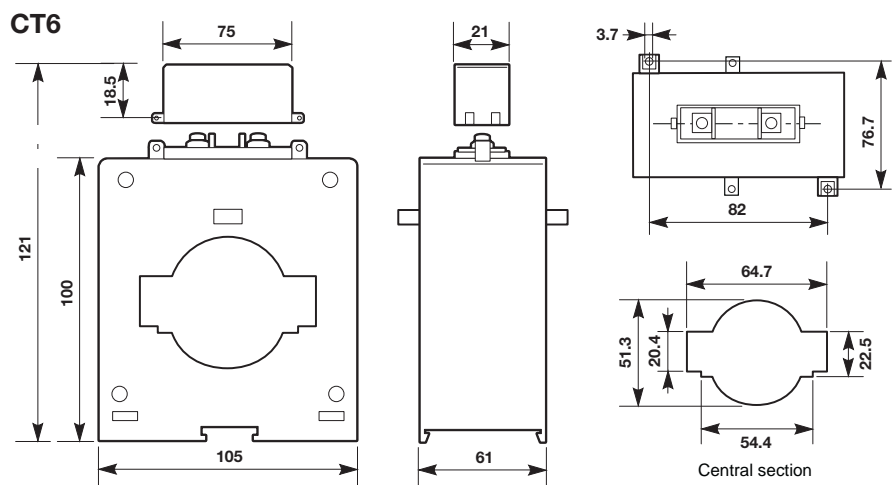
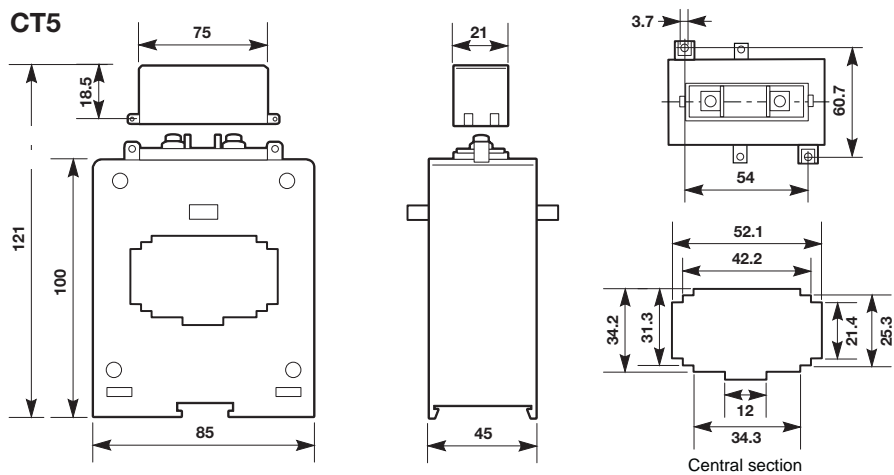
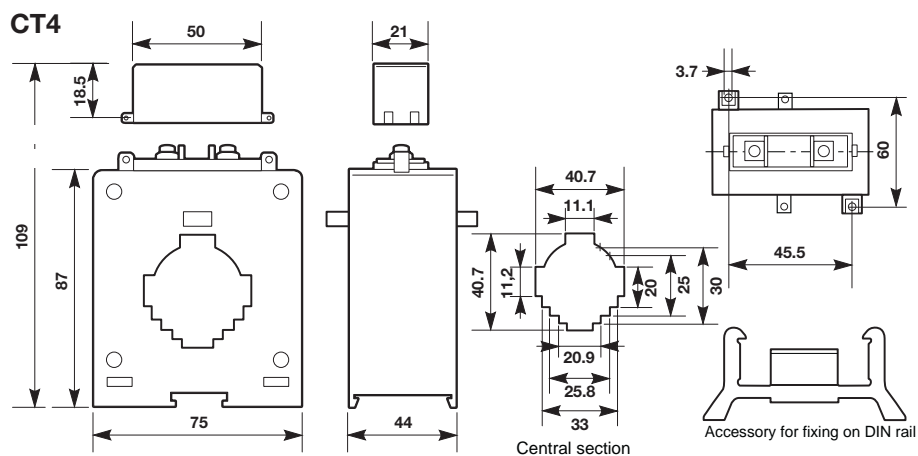

CT8

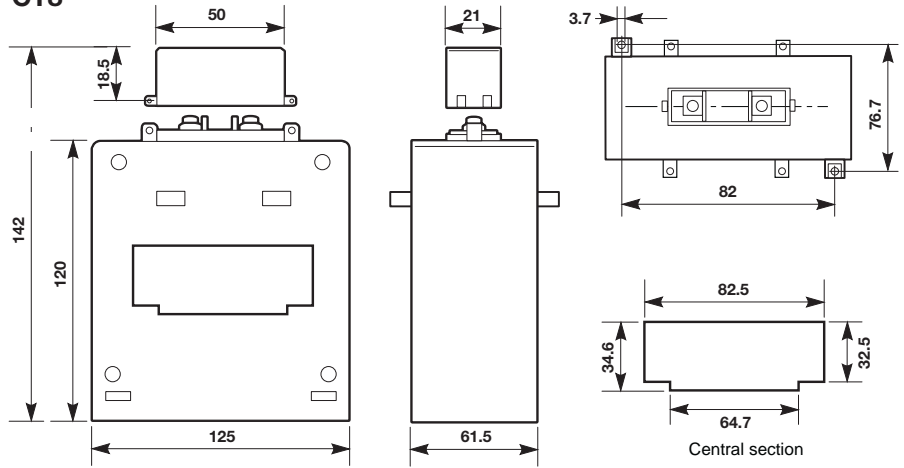

CT8-V

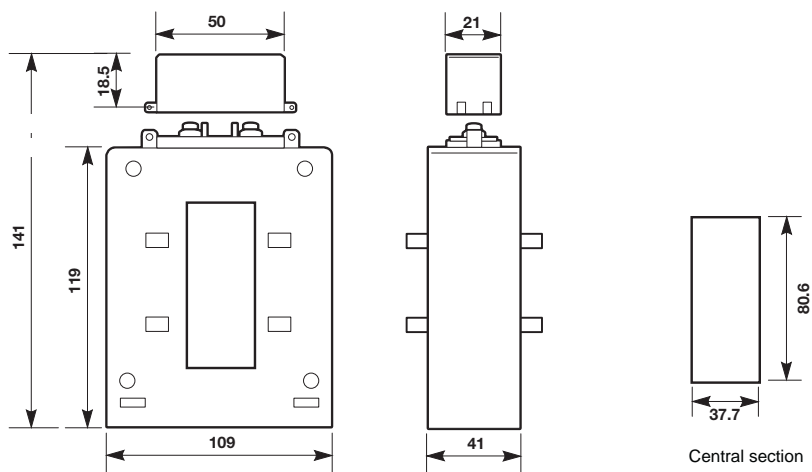

CT12

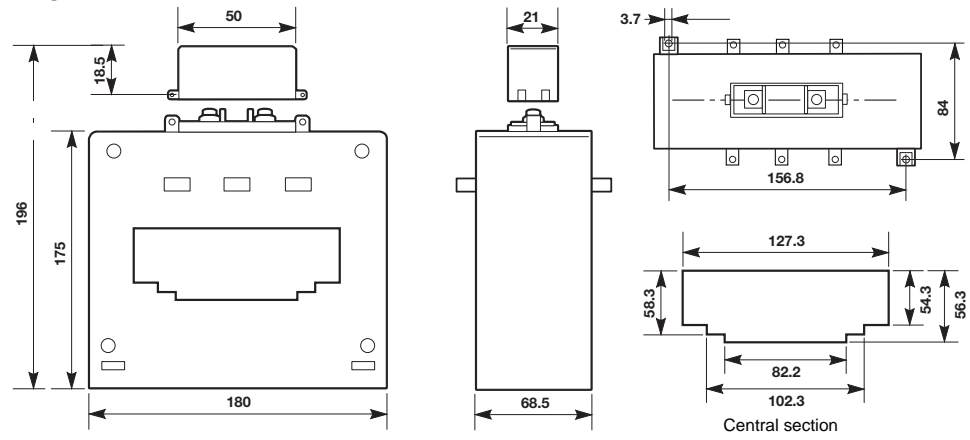

CT12-V

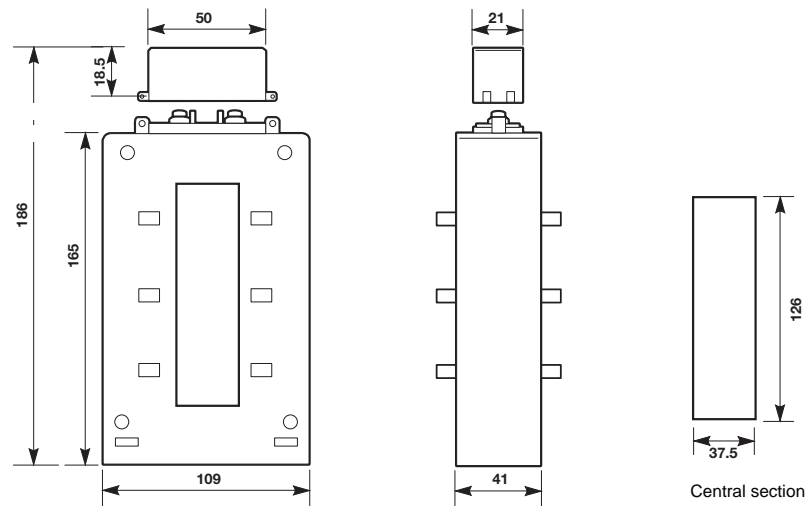

Compact type current transformers

CT-M1

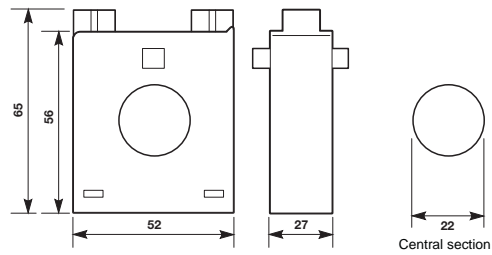

CT-M3

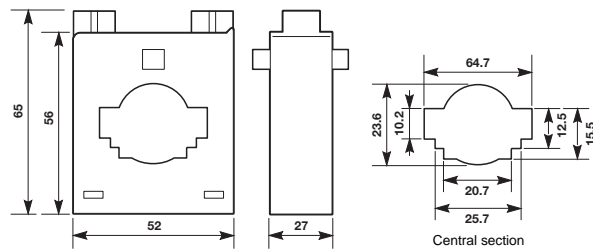

CT-M4

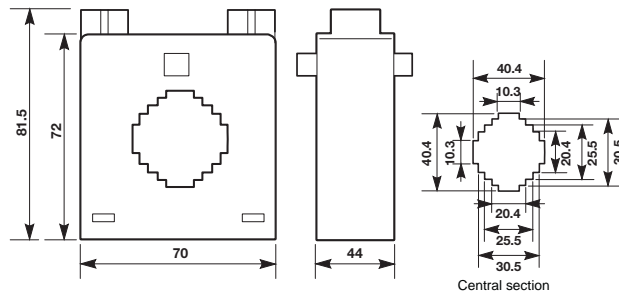

CT-M5

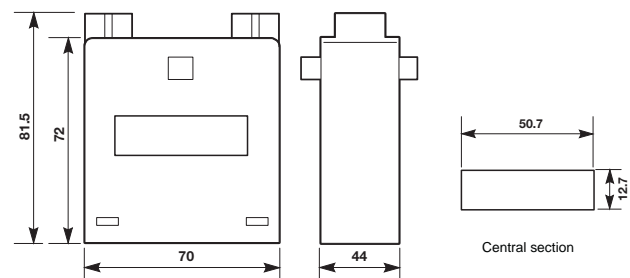

CT-M6

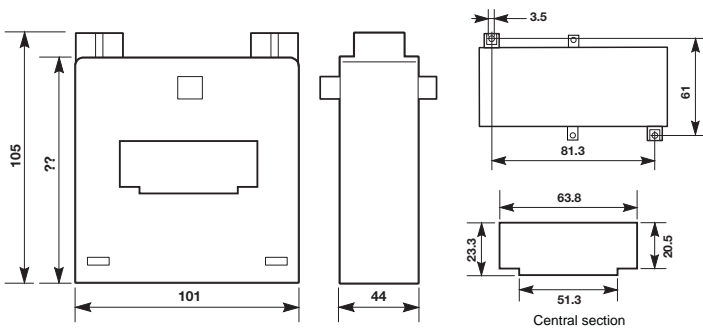

Miniaturized type current transformers

CT-SM1

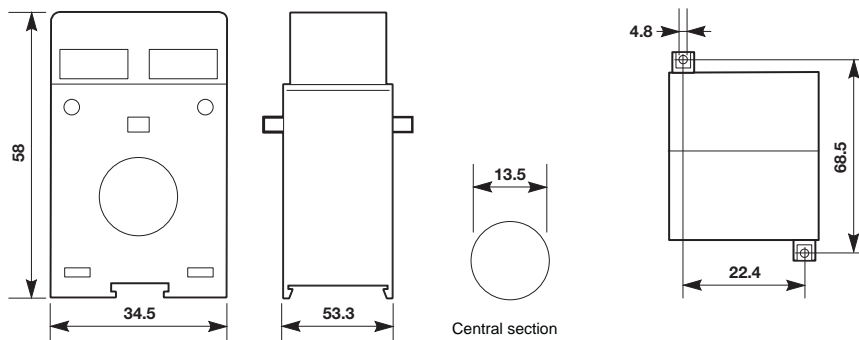

CT-SM2

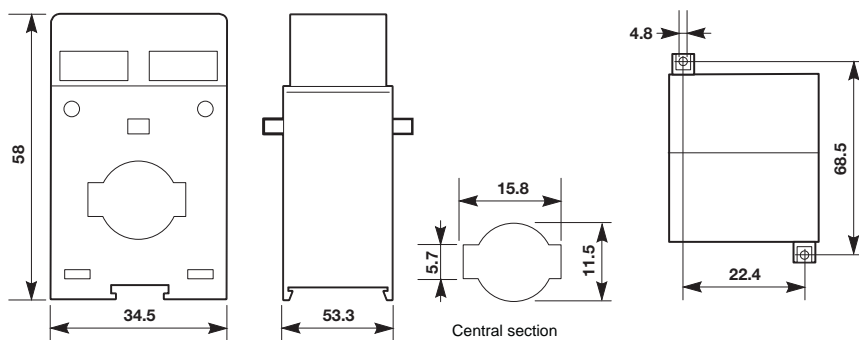

CT-SM3

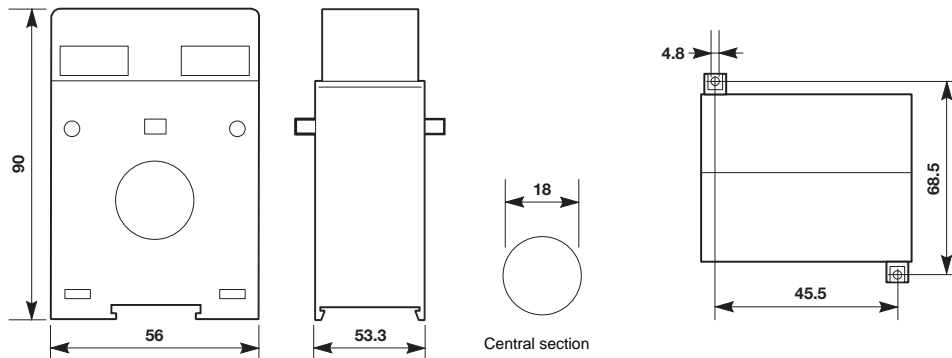

CT-SM4

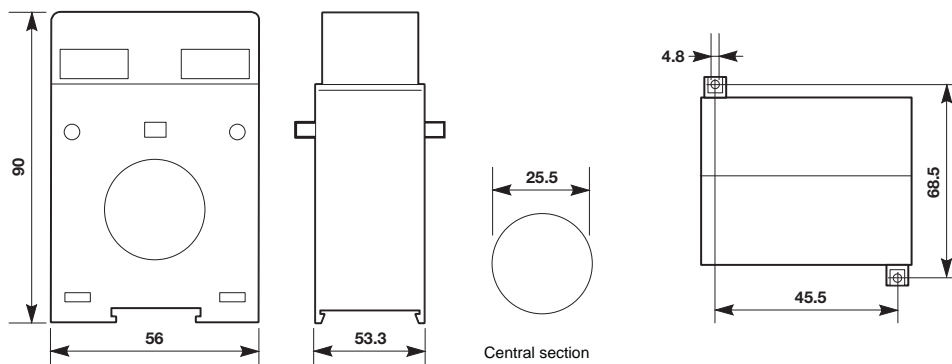

CT-SM5

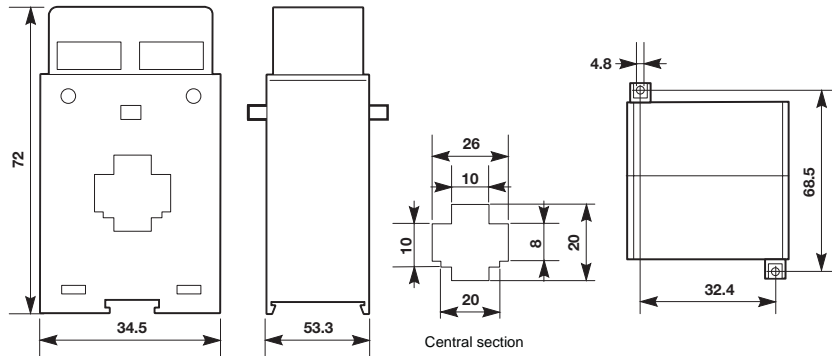

CT-SM6

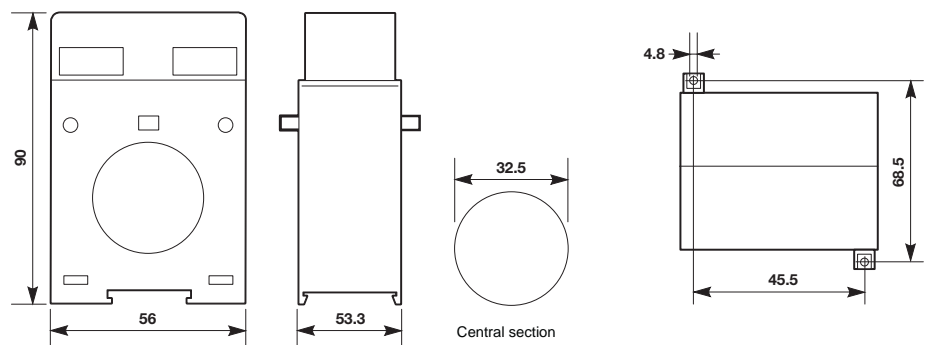

CT-SM7

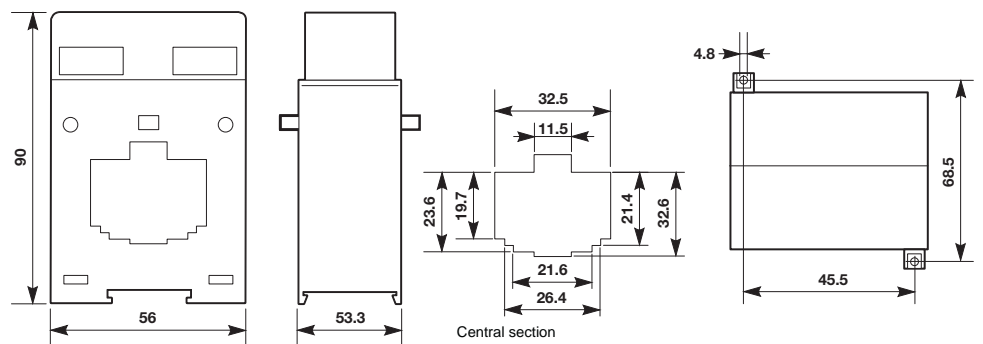

CT-SM8

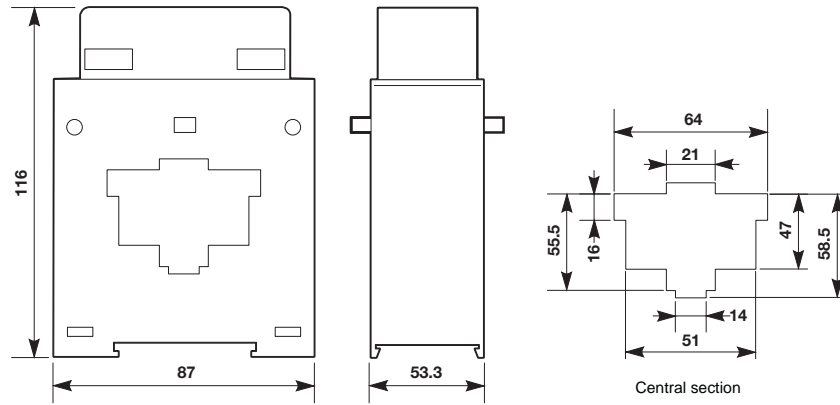

CT-SM9

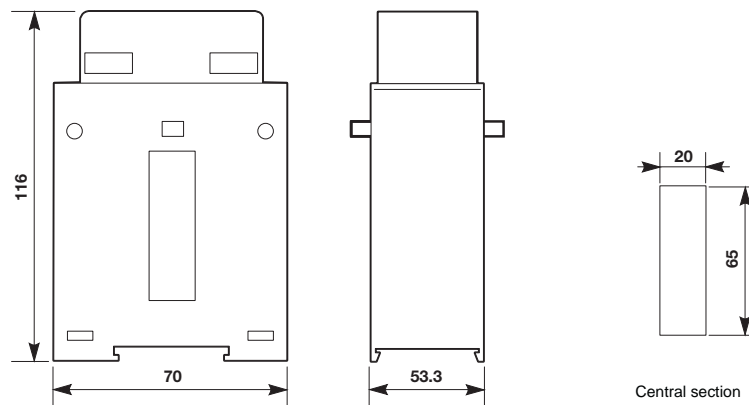

Protection type current transformers

CTP1

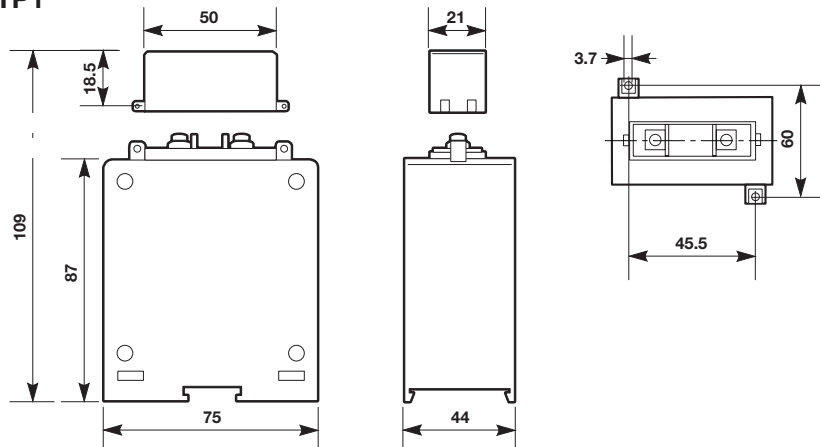

CTP2

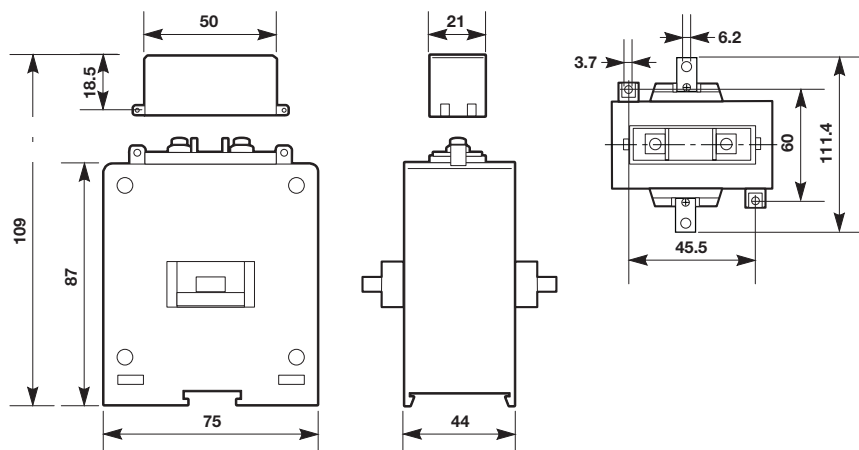

CTP5

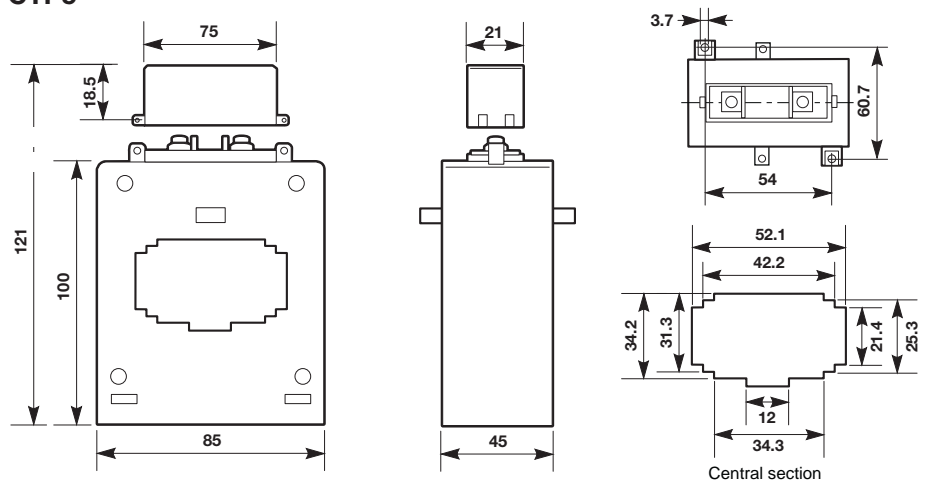

CTP6

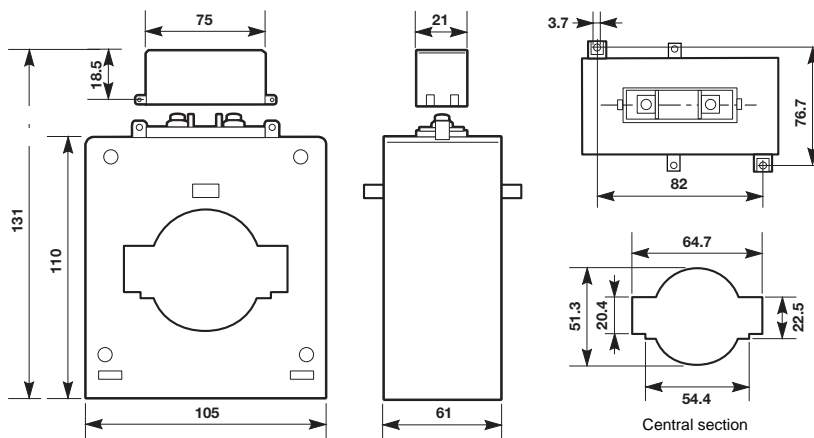

CTP8

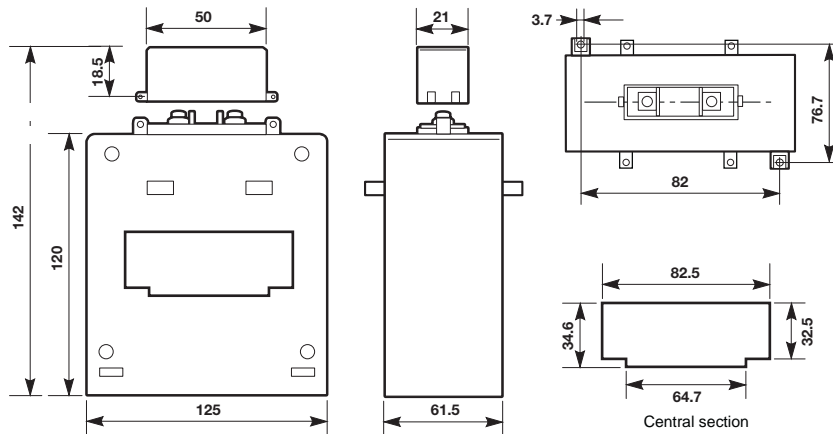

CTP12

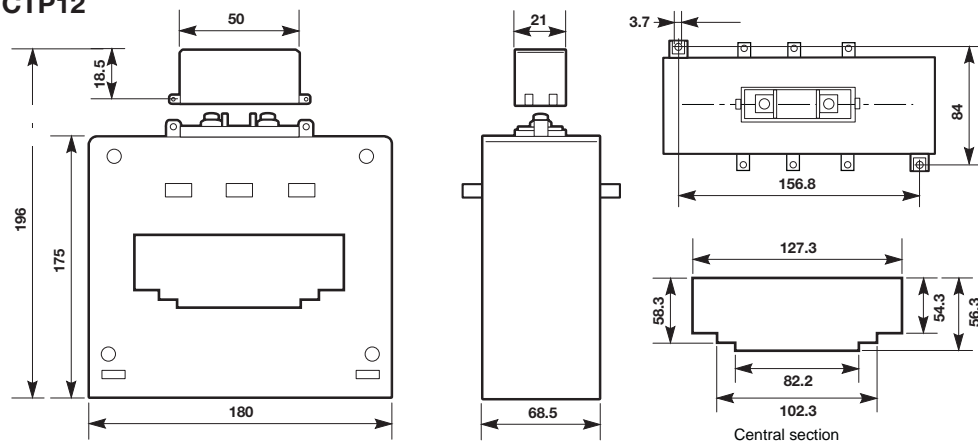

Summing current transformers

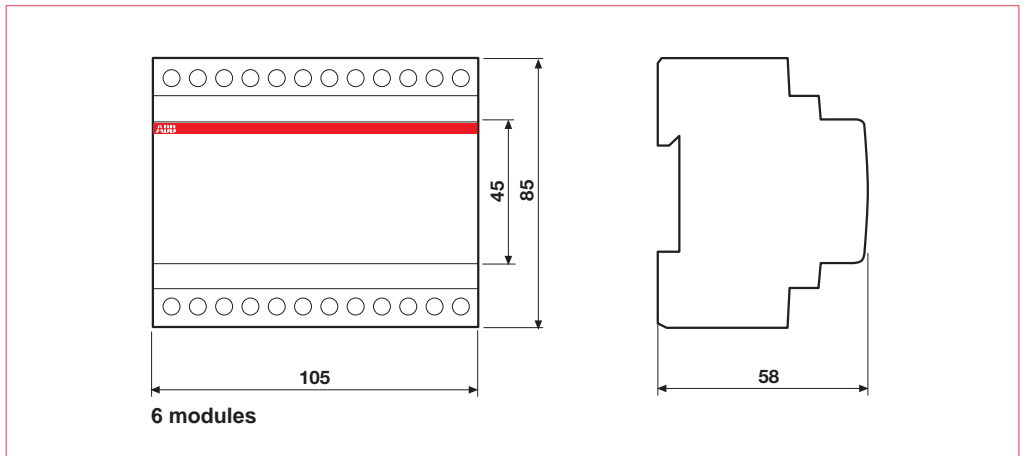

Voltage transformers

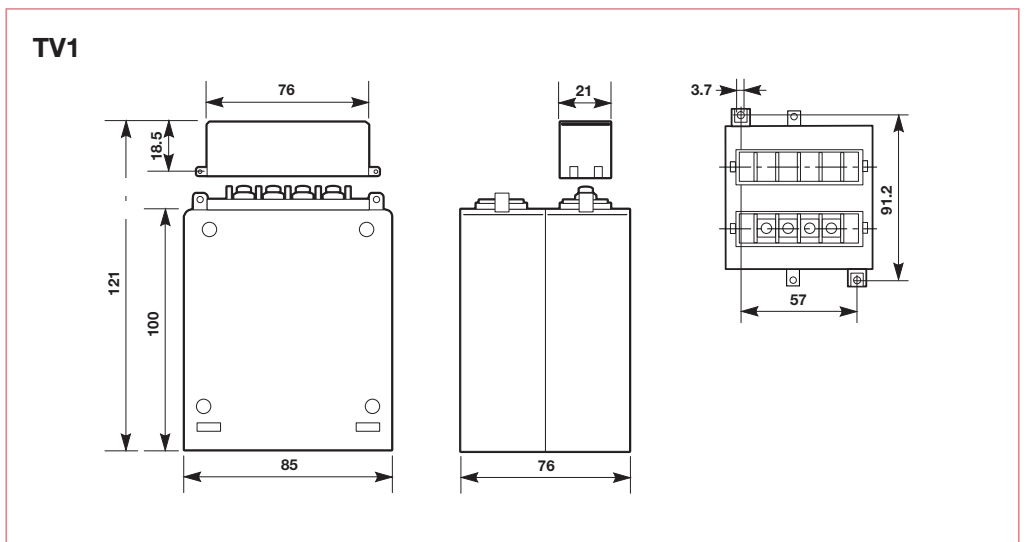

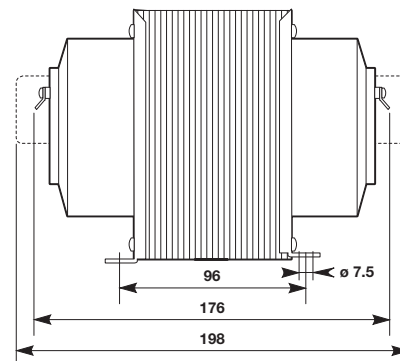
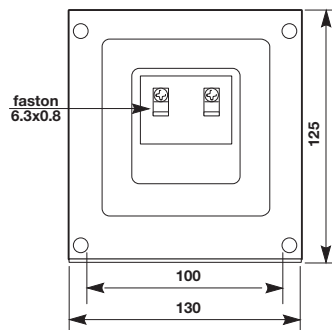
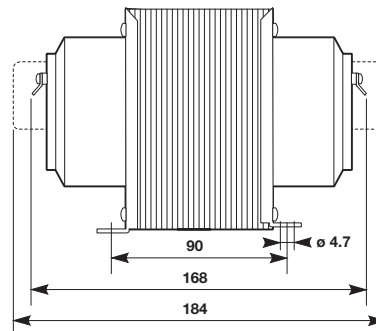
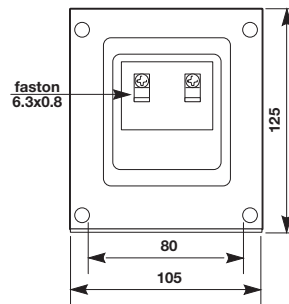
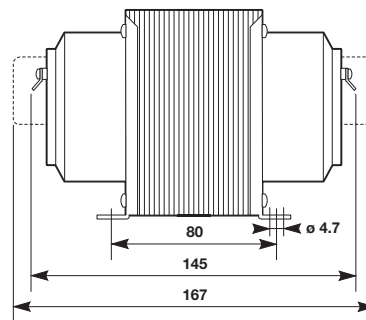
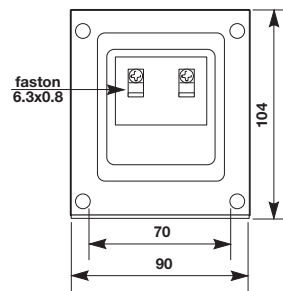
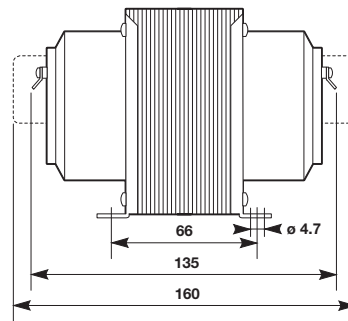
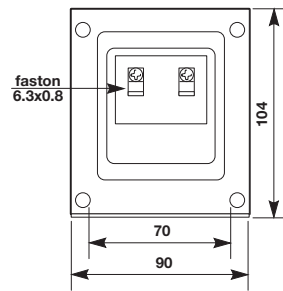

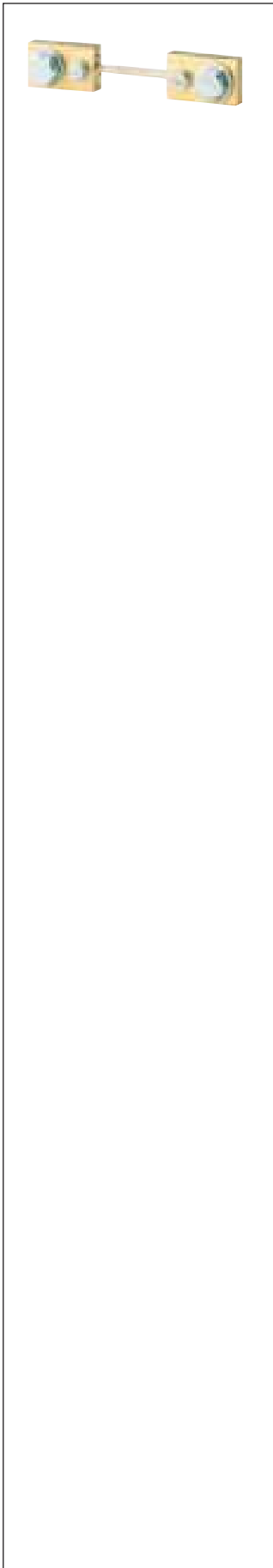

Shunts

SNT1 - 25 A/60 mV

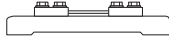

SNT1 - 25 A/150 mV

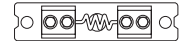

SNT30 - 150 A/60 mV



SNT30 - 200 A/150 mV



SNT200 - 350 A/60 mV

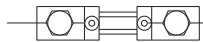
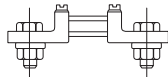

SNT200 - 350 A/150 mV

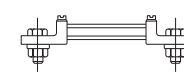

SNT400 - 700 A/60 mV

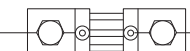
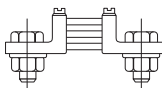

SNT400 - 700 A/150 mV

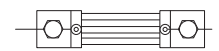
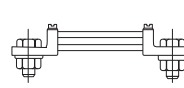

SNT750 - 1000 A/60 mV

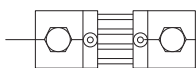
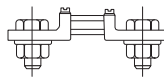

SNT750 - 1000 A/150 mV

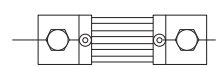
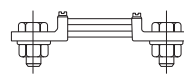

SNT1200 - 1500 A/60 mV

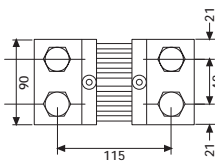
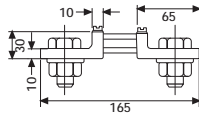

SNT1200 - 1500 A/150 mV

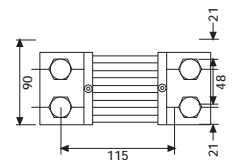
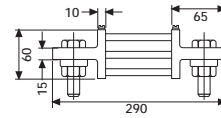

SNT2000 - 2500 A/60 mV

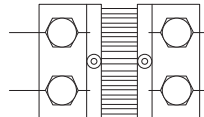
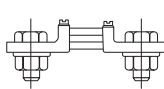

SNT2000 - 2500 A/150 mV

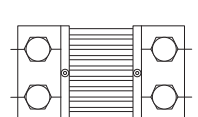
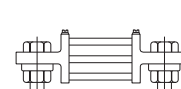

SNT4000 A/60 mV

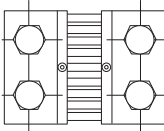
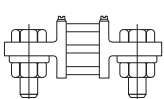

SNT4000 A/150 mV

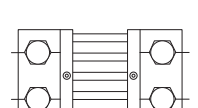
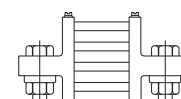

SNT5000 - 6000 A/60 mV

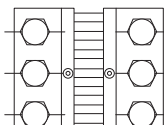
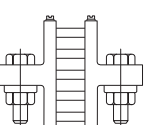

SNT5000 - 6000 A/150 mV

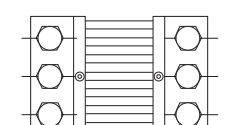
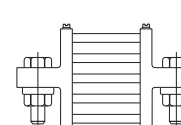



CONV and CNV

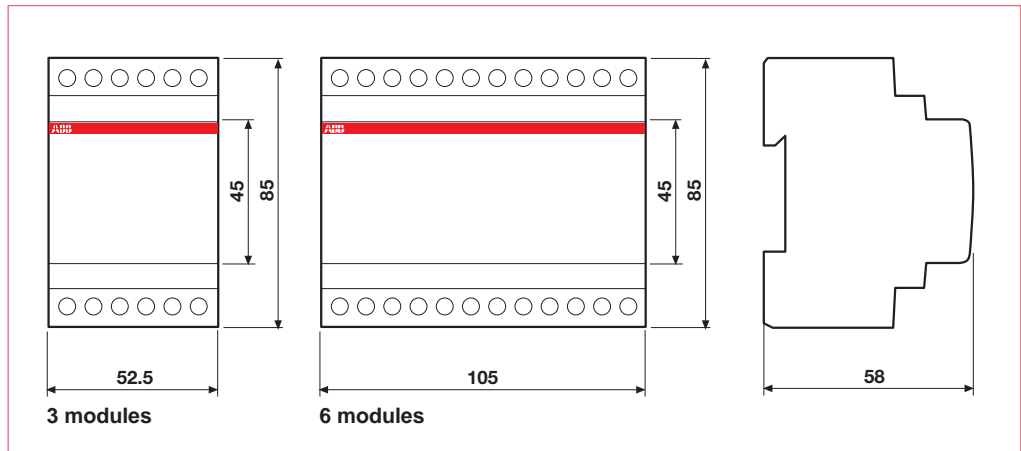

E 233 electro-mechanical hour counters

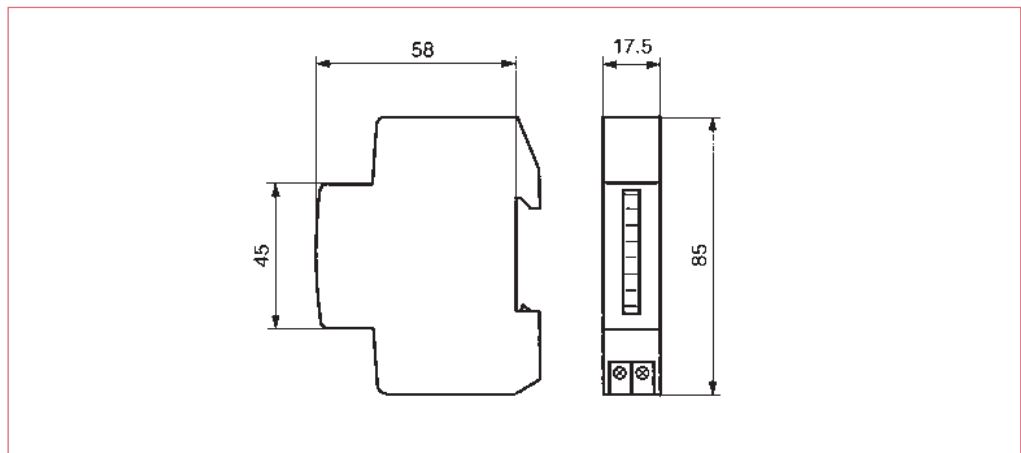

HMT electro-mechanical hour counters

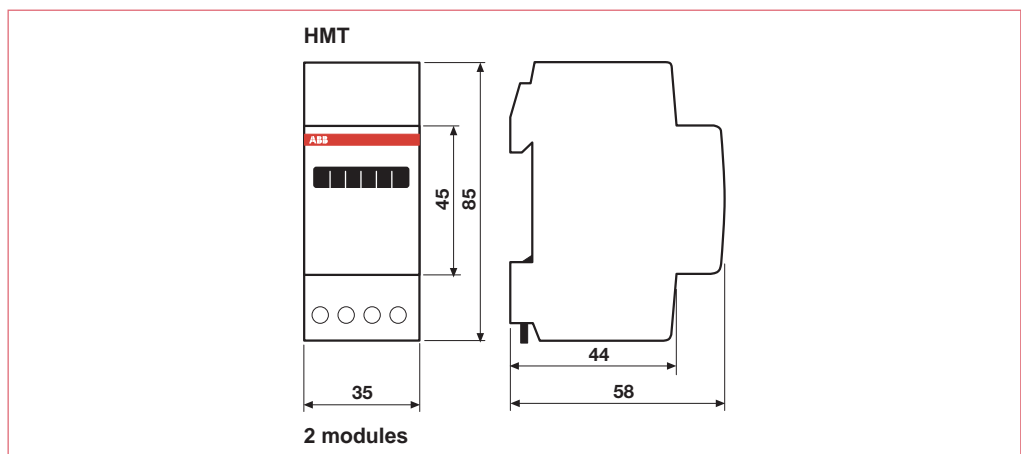



Isoltester-DIG-RZ, Isoltester-DIG-PLUS

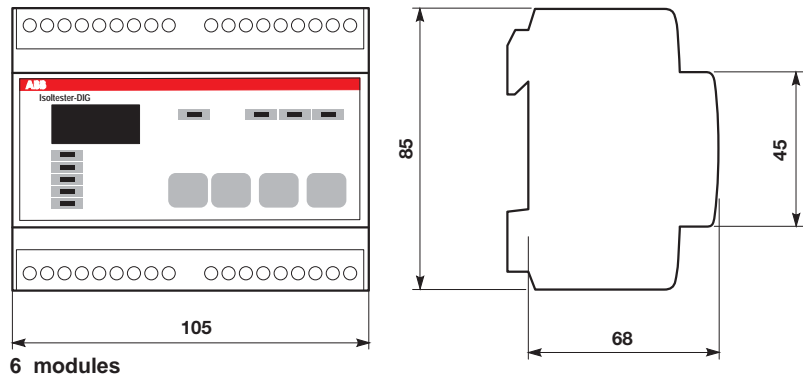

Selvtester

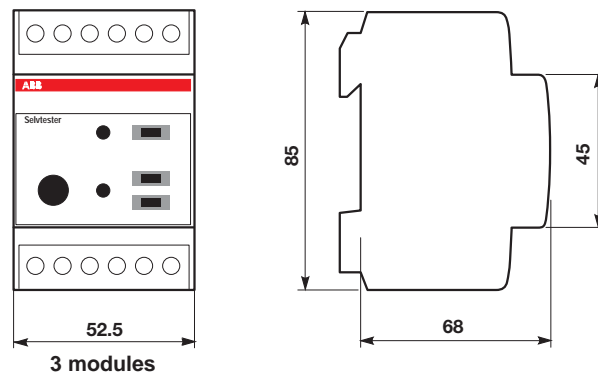

QSD panels for remote signalling

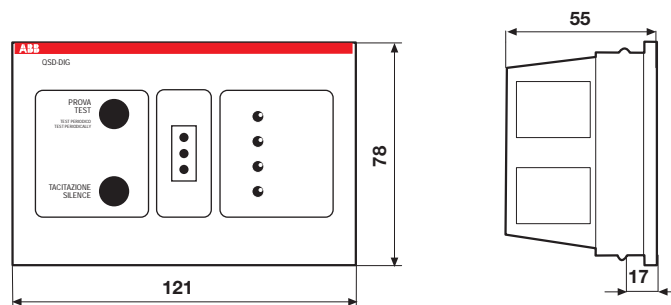



EMT electronic single phase energy meters

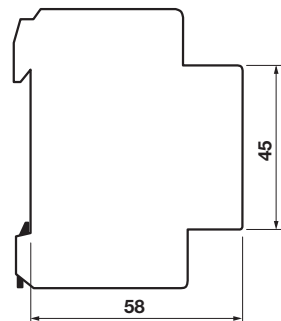
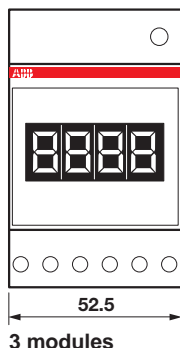

ODIN single electronic single phase energy meters

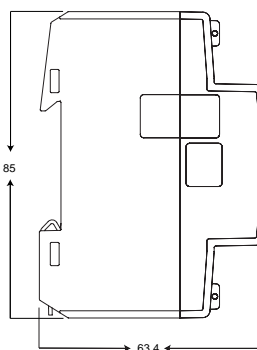
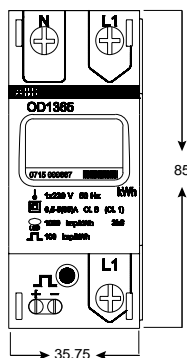

ODIN Meter electronic three-phase energy meters

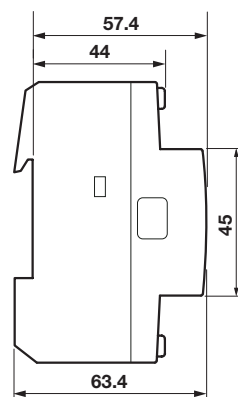
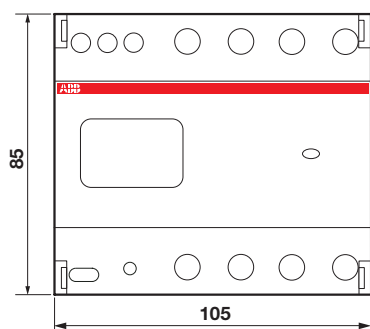



DELTA single electronic single phase energy meters

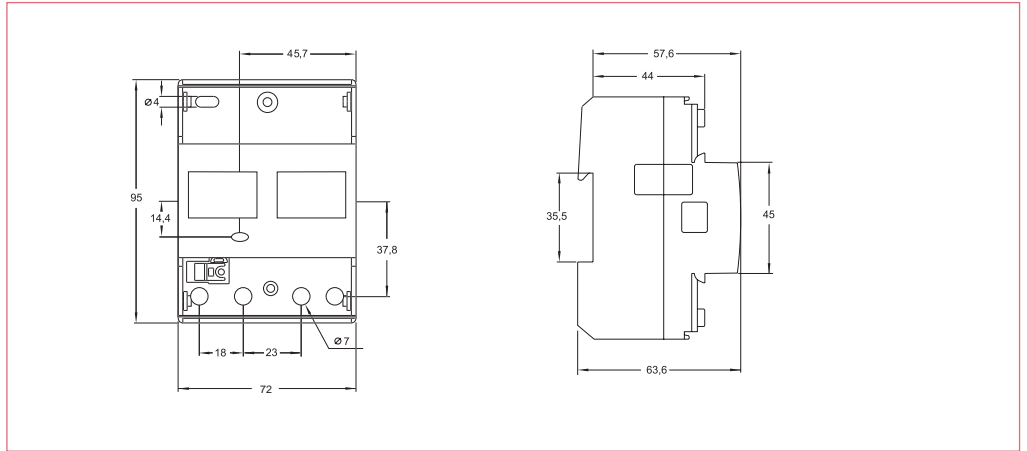

DELTA plus electronic three-phase energy meters

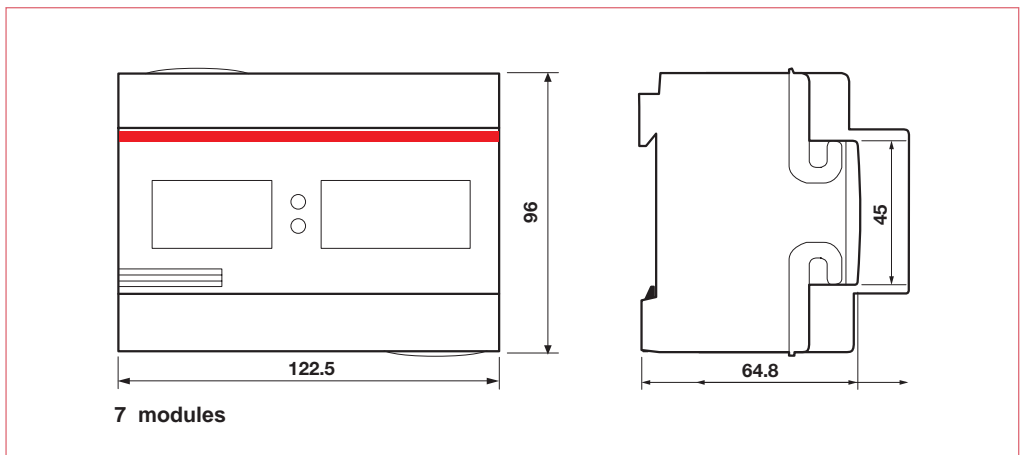



TS-C

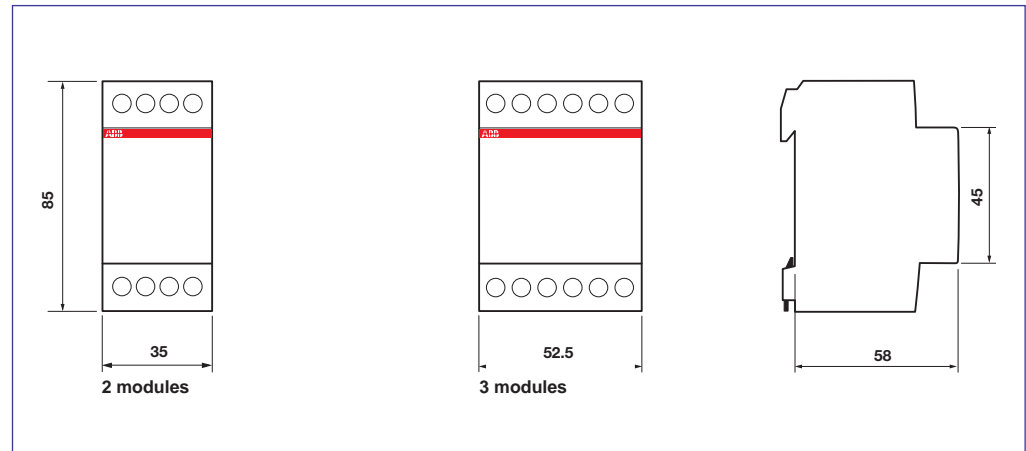

TM/TS bell transformers

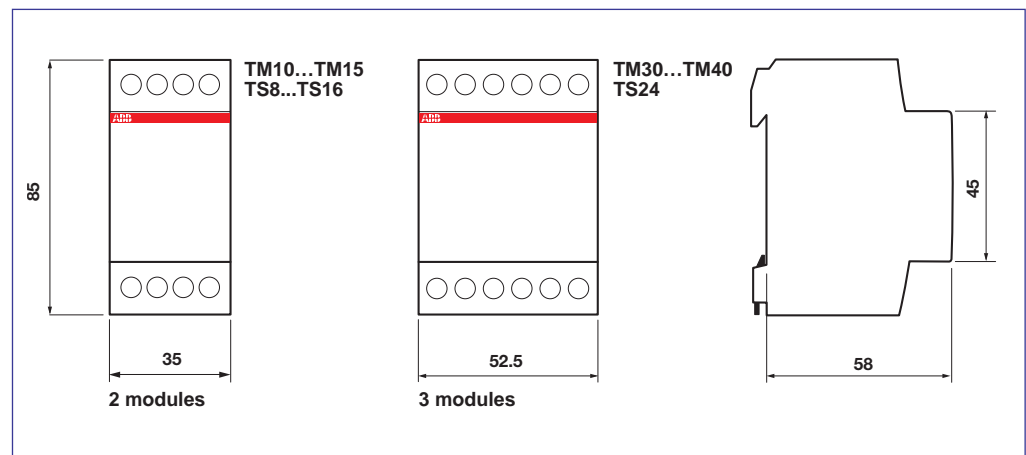

2CDC 271 025 F0007



CP-D primary switch mode power supplies

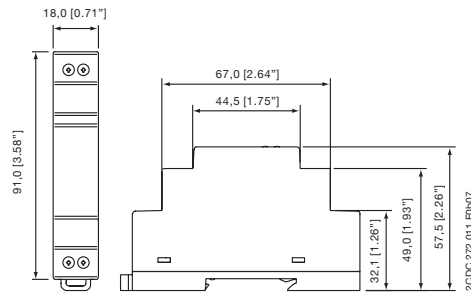

CP-D 12/0.83, CP-D 24/0.42

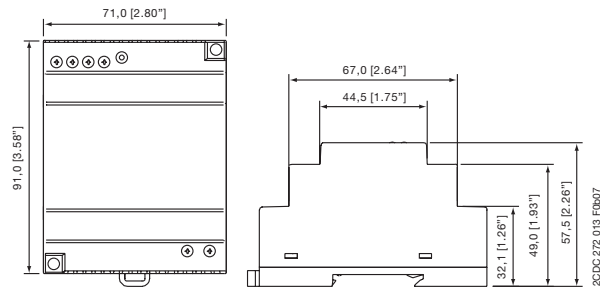

CP-D 24/2.5

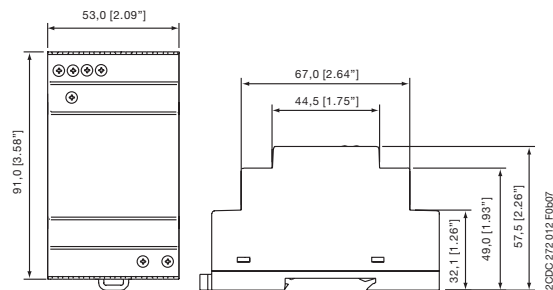

CP-D 12/2.1, CP-D 24/1.3

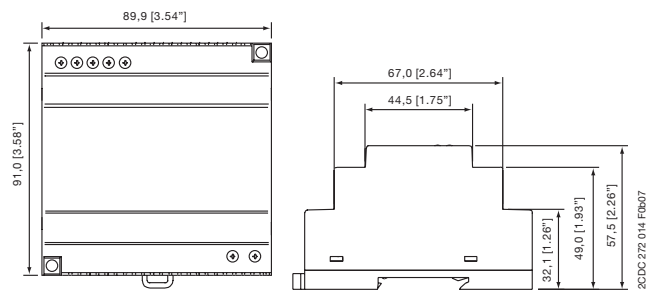

CP-D 24/4.2



Bells and buzzers

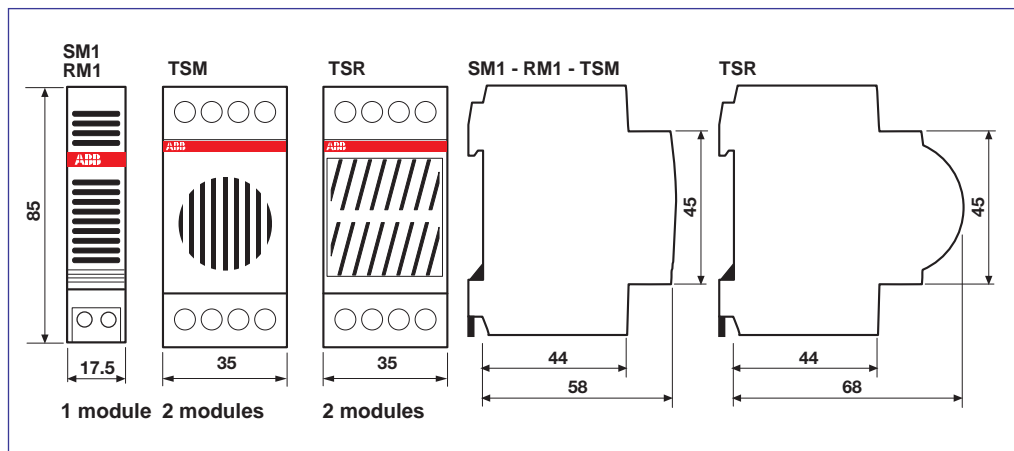

Modular sockets

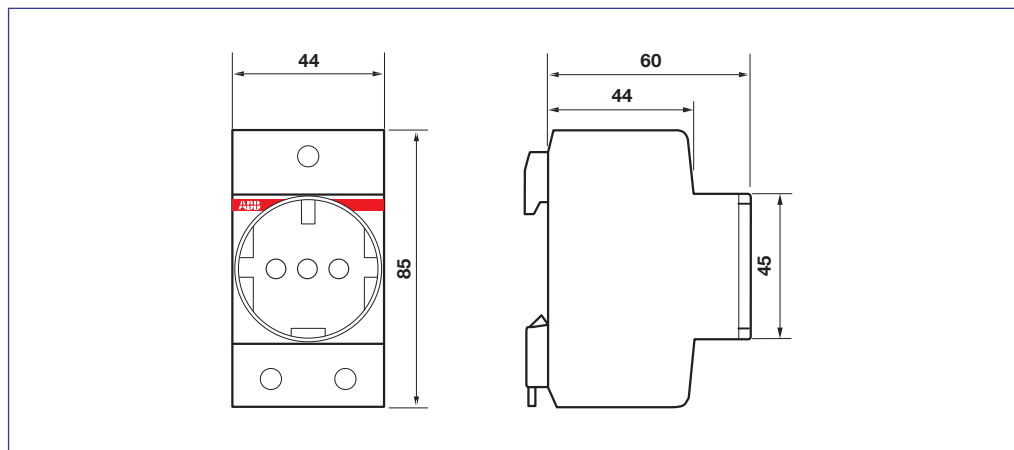

MA1-8001 DIN rail adapter

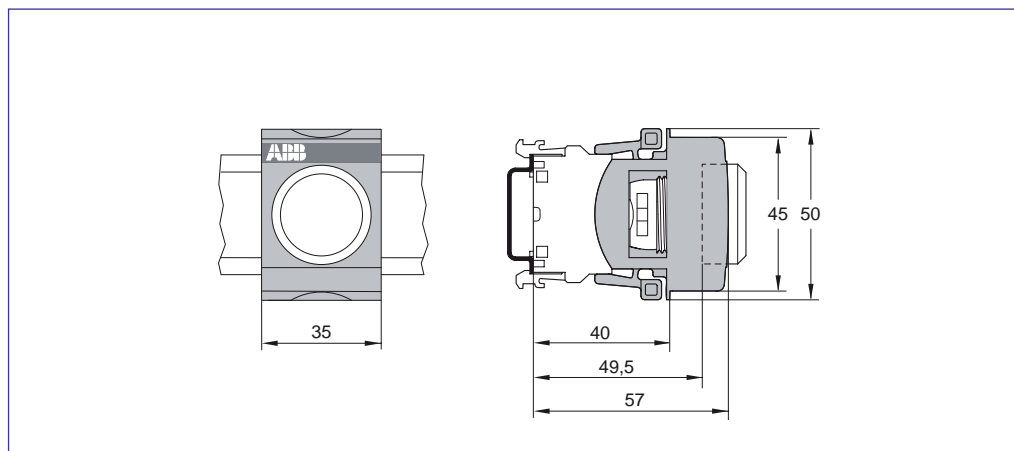















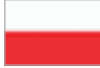





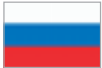



Index

Worldwide marks and approvals.....	14/2
------------------------------------	------

System pro M compact® MCBs and RCDs

Worldwide marks and approvals

This is the present situation regarding worldwide marks and approvals for ABB System pro M compact range devices. Although some products already obtained some approvals or certificates, they don't necessarily bear the related marks on the product.

	 AENOR Spain 	 BBJ Poland 	 CCC China 	 CEBEC Belgium 
S 200	■	■		■
S 200 M	■	■		■
S 200 P	■	■		■
S 200 U				
S 200 UP				
S 9..			■	
S 280			■	
S 290			■	
S 800			■	
F 200	■		■	■
DDA 200				
FS 201		■		■
DS 200				
DS 200 M				
DS 9..			■	■
DS 271				
DDA for S 290				
DDA 800				
	 GOST Russia 	 IMQ Italy 	 KEMA Netherland 	 LCIE France 
S 200	■	■	■	■
S 200 M	■	■	■	■
S 200 P	■	■	■	■
S 200 U				
S 200 UP				
S 9..		■	■	■
S 280	■	■		■
S 290				■
S 800	■			
F 200	■	■	■	■
DDA 200	■	■		■
FS 201	■	■	■	■
DS 200	■	■		
DS 200 M	■	■		
DS 9..	■	■	■	■
DS 271				
DDA for S 290				
DDA 800				
	 SIQ Slovenia 	 SIRIM Malaysia 	 TICK Australia 	 UL USA 
S 200	■	■	■	①
S 200 M	■	■	■	■
S 200 P	■	■	■	①
S 200 U				②
S 200 UP				②
S 9..				
S 280			■	
S 290				■
S 800				
F 200		■	■	■
DDA 200				
FS 201				■
DS 200				
DS 200 M				
DS 9..			■	
DS 271			■	
DDA for S 290				
DDA 800				

The F 200 range has obtained the EPD (Environmental Product Declaration), according to ISO 14040.



■ APPROVED ① SUPPLEMENTARY PROTECTION ② BRANCH CIRCUIT PROTECTION

System Worldwide marks and approvals

pro M compact® MCBs and RCDs



CERTIF
Portugal



CSA
Canada

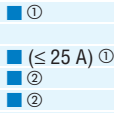

DEMKO
Denmark



EVPU
Slovakia



EZU
Czech Rep.



FIMKO
Finland



NEMKO
Norway



OVE
Austria



PSB
Singapore



SABS
South Africa



SEMKO
Sweden



SEV
Switzerland



VDE
Germany



BV
France



DNV
Norway



GL
Germany



LRS
Great Britain



RINA
Italy



RMRS
Russia



Indicated approvals are the whole of the approvals for all device versions; contact your LSO to know which are the approvals obtained for each device version

System pro M compact®

Worldwide marks and approvals

Modular devices



CCC
China



GOST
Russia

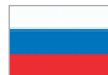

IMQ
Italy



KEMA
Netherland



OVR T1				
MS 225		■		
E 930	①	①	■	
E 200	■			■
RS370				
E 220		■	■	
ESB	■			
EN	■			
E 259		■		
E 250		■		
E 260		■		
E 234	■	■		
AT		■	■	
DT		■	■	
E 232		■		
TW		■	■	
RAL		■		
LSS1/2		■		
RLI / RHI / RHV		■		
SQZ3		■		
LEE 230		■		
CT / CTA / TRFM		■		
TM		■	■ ③	④
TS		■		
TS-C		■	■	
TSM/TSR		■		
SM/RM		■		
M1170		■		
M1173		■	■	
M1174		■		
M1175		■		

- Whole range
- ① Only E 930 32 A
- ② Except for ESB/EN 20
- ③ Except for TM40
- ④ Only TS8/8 SWH



In consideration of modifications to Standards and materials, the characteristics and overall dimensions indicated in this catalogue may be considered binding only following confirmation by ABB

2CSC400002D0206 - October '07
Printed in Italy
18.000 - CAL

ABB SACE - A Division of ABB S.p.A.
ABB STOTZ-KONTAKT GmbH